

SIEMENS

Ingenuity for life

24/7

NEWS

Industry Online Support

Home

Assignment of PROFIsafe Addresses via User Program

Safety Integrated

<https://support.industry.siemens.com/cs/ww/en/view/109748466>

Siemens
Industry
Online
Support



Legal information

Use of application examples

Application examples illustrate the solution of automation tasks through an interaction of several components in the form of text, graphics and/or software modules. The application examples are a free service by Siemens AG and/or a subsidiary of Siemens AG ("Siemens"). They are non-binding and make no claim to completeness or functionality regarding configuration and equipment. The application examples merely offer help with typical tasks; they do not constitute customer-specific solutions. You yourself are responsible for the proper and safe operation of the products in accordance with applicable regulations and must also check the function of the respective application example and customize it for your system.

Siemens grants you the non-exclusive, non-sublicensable and non-transferable right to have the application examples used by technically trained personnel. Any change to the application examples is your responsibility. Sharing the application examples with third parties or copying the application examples or excerpts thereof is permitted only in combination with your own products. The application examples are not required to undergo the customary tests and quality inspections of a chargeable product; they may have functional and performance defects as well as errors. It is your responsibility to use them in such a manner that any malfunctions that may occur do not result in property damage or injury to persons.

Disclaimer of liability

Siemens shall not assume any liability, for any legal reason whatsoever, including, without limitation, liability for the usability, availability, completeness and freedom from defects of the application examples as well as for related information, configuration and performance data and any damage caused thereby. This shall not apply in cases of mandatory liability, for example under the German Product Liability Act, or in cases of intent, gross negligence, or culpable loss of life, bodily injury or damage to health, non-compliance with a guarantee, fraudulent non-disclosure of a defect, or culpable breach of material contractual obligations. Claims for damages arising from a breach of material contractual obligations shall however be limited to the foreseeable damage typical of the type of agreement, unless liability arises from intent or gross negligence or is based on loss of life, bodily injury or damage to health. The foregoing provisions do not imply any change in the burden of proof to your detriment. You shall indemnify Siemens against existing or future claims of third parties in this connection except where Siemens is mandatorily liable.

By using the application examples you acknowledge that Siemens cannot be held liable for any damage beyond the liability provisions described.

Other information

Siemens reserves the right to make changes to the application examples at any time without notice. In case of discrepancies between the suggestions in the application examples and other Siemens publications such as catalogs, the content of the other documentation shall have precedence.

The Siemens terms of use (<https://support.industry.siemens.com>) shall also apply.

Security information

Siemens provides products and solutions with Industrial Security functions that support the secure operation of plants, systems, machines and networks.

In order to protect plants, systems, machines and networks against cyber threats, it is necessary to implement – and continuously maintain – a holistic, state-of-the-art industrial security concept. Siemens' products and solutions constitute one element of such a concept.

Customers are responsible for preventing unauthorized access to their plants, systems, machines and networks. Such systems, machines and components should only be connected to an enterprise network or the Internet if and to the extent such a connection is necessary and only when appropriate security measures (e.g. firewalls and/or network segmentation) are in place. For additional information on industrial security measures that may be implemented, please visit <https://www.siemens.com/industrialsecurity>.

Siemens' products and solutions undergo continuous development to make them more secure. Siemens strongly recommends that product updates are applied as soon as they are available and that the latest product versions are used. Use of product versions that are no longer supported, and failure to apply the latest updates may increase customer's exposure to cyber threats.

To stay informed about product updates, subscribe to the Siemens Industrial Security RSS Feed at: <https://www.siemens.com/industrialsecurity>.

Contents

Legal information	2
Contents	3
1 Validity	4
2 Assignment of the PROFIsafe Address via Engineering Tool	5
3 Motivation for the FB "PROFIsafeAddrAssign"	6
4 Description of the FB "PROFIsafeAddrAssign"	7
4.1 Block Parameters of the FB "PROFIsafeAddrAssign"	7
4.2 Call Sequence of the Parameters	8
4.3 Error Handling	10
4.4 S7 Diagnostics Messages	11
5 Instructions for Implementing the FB "PROFIsafeAddrAssign"	13
5.1 Instructions for Writing the Memory Card.....	13
5.2 Automatic PROFIsafe Address Assignment via a STEP 7 Program.....	15
5.2.1 Conditions for the Machine Manufacturer	15
5.2.2 Conditions for the Commissioning Engineer	17
5.2.3 General Procedure	18
5.2.4 Parameter Data Record	18
5.2.5 PROFIsafe Address Assignment Without Configuration Control	20
5.2.6 PROFIsafe Address Assignment With Configuration Control	21
1 Appendix	23
1.1 Service and support	23
1.2 Related literature	24
1.3 Change documentation	24

1 Validity

F CPUs

The information in this document is valid for the following F-CPU:

- S7-1500 with firmware version V2.8 and higher
- S7-1500 Software Controller with Version 21.9 and higher

The descriptions and instructions in this document are based on the S7-1500 and TIA Portal.

Distributed IO

The information in this document is valid for the following F modules of the ET 200SP in the central and distributed configuration:

- Digital input module F-DI 8x24VDC HF (article number 6ES7136-6BA00-0CA0 onwards)
- Digital output module F-DQ 4x24VDC/2A PM HF (article number 6ES7136-6DB00-0CA0 onwards)
- Digital output module F-DQ 8x24VDC/0.5A PP HF (article number 6ES7136-6DC00-0CA0 onwards)
- Power module F-PM-E 24VDC/8A PPM ST (article number 6ES7136-6PA00-0BC0 onwards)
- Analog input modul F-AI 4xI 0(4)..20mA 2-/4-wire HF (article number 6ES37136-6AA00-0CA1 onwards)
- Analog input modul F-AI 4xU 0..10V HF (article number 6ES7136-6AB00-0CA1 onwards)
- Counter module F-TM Count 1x1Vpp sin/cos HF (article number 6ES7136-6CB00-0CA0 onwards) The F module can only be used from STEP 7 Safety V17. You can upgrade your project for this.

Note

The PROFIsafe addresses cannot be assigned to the following modules via the FB "PROFIsafeAddrAssign" described here:

- Modules of the ET 200MP and MP modules in central configuration
- Modules of the ET 200eco PN
- IO modules with DIP switch

Note

The PROFIsafe address (code name in accordance with IEC 61784-3-3: 2010) is for the unique identification of source and destination. Therefore each F IO has two address parts:

- F source address
- F destination address

You can use one or both address parts for protection.

More information is available in the following entry:

<https://support.industry.siemens.com/cs/ww/en/view/109479905>

2 Assignment of the PROFIsafe Address via Engineering Tool

If assignment of the PROFIsafe address is made via an Engineering Tool (TIA Portal, for example), this has to be done in this way for each individual machine. The project has to be loaded into the controller before the PROFIsafe addresses can be assigned.

The figure below outlines this procedure.

Figure 2-1: Assignment of PROFIsafe addresses via HW Config

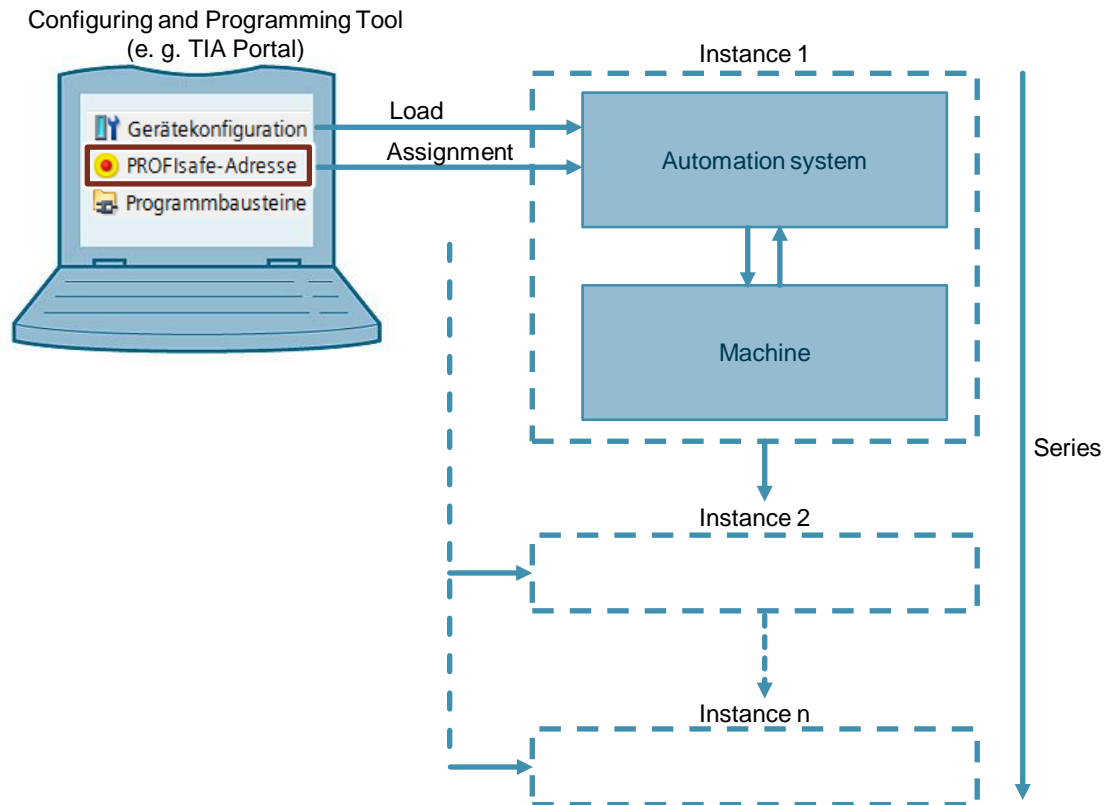

3 Motivation for the FB "PROFIsafeAddrAssign"

Motivation

Using this FB you can assign the PROFIsafe address without additional Engineering. This significantly reduces time and effort in the case of series machines.

Basic Principles

Using this procedure the memory card of the configuring and programming tool is written so that it can then also be used for other controllers with the same configuration for assigning the PROFIsafe address.

The standard block FB "PROFIsafeAddrAssign" makes this possible. This FB was developed for implementing the distributed IO system ET 200SP in series machine construction.

The figure below outlines this procedure.

Figure 3-1: Assignment of PROFIsafe addresses via user program

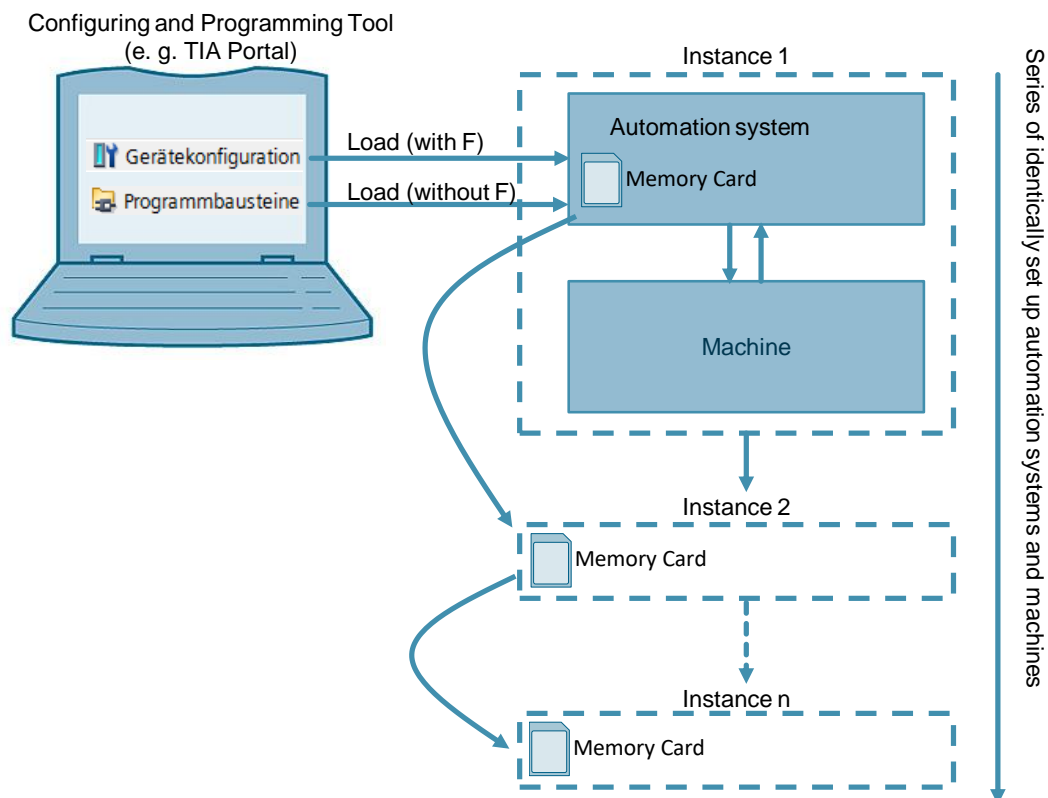

Note Section [5.1](#) deals with loading with F and without F.

4 Description of the FB "PROFIsafeAddrAssign"

4.1 Block Parameters of the FB "PROFIsafeAddrAssign"

In the following we provide information about the FB "PROFIsafeAddrAssign" that assigns the PROFIsafe addresses.

Block

Figure 4-1 FB "PROFIsafeAddrAssign"

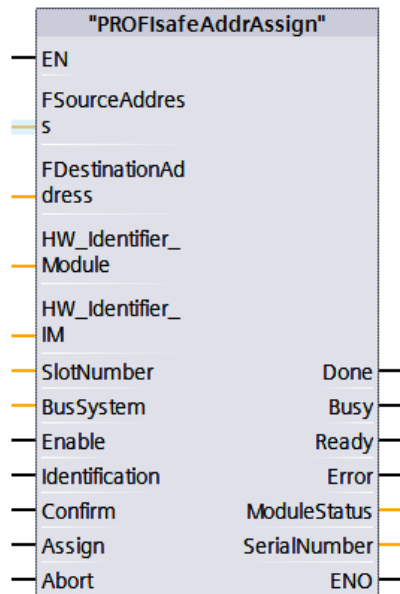

© Siemens AG 2023 All rights reserved

Inputs

Table 4-1: Inputs of the FB "PROFIsafeAddrAssign"

Parameter	Data type/ HW Config	Description
FSourceAddress	DINT	F source address
FDestinationAddress	DINT	F destination address
HW_Identifier_Module	HW_IO	Hardware ID of the F module
HW_Identifier_IM	HW_IO	Hardware ID of the interface module
SlotNumber	INT	Slot number
BusSystem	INT	1: PROFIBUS 2: PROFINET 3: Central
Enable	BOOLEAN	<u>Positive edge</u> : Address assignment is started. <u>Negative edge</u> : Address is reset, the F module returns to its original status.
Identification	BOOLEAN	<u>Positive edge</u> : Command is executed. <ul style="list-style-type: none"> The channel status LEDs of the F module flash green

Parameter	Data type/ HW Config	Description
		<ul style="list-style-type: none"> The DIAG LED flashes red The serial number of the interface module is displayed <u>Negative edge (during address assignment):</u> <ul style="list-style-type: none"> Abort with error output When address assignment is started again, the input must also be set again.
Confirm	BOOLEAN	<u>Positive edge:</u> Command is executed. <ul style="list-style-type: none"> You confirm that the correct module is flashing. <u>Negative edge (during address assignment):</u> <ul style="list-style-type: none"> Abort with error output When address assignment is started again, the input must also be set again.
Assign	BOOLEAN	<u>Positive edge:</u> Command is executed. <ul style="list-style-type: none"> The flashing F module is addressed. When address assignment is started again, the input must also be set again.
Abort	BOOLEAN	Abort by user.

Outputs

Table 4-2: Outputs of the FB "PROFIsafeAddrAssign"

Parameter	Data type/ HW Config	Description
Done	BOOLEAN	A valid PROFIsafe address has been assigned to the F module.
Busy	BOOLEAN	The PROFIsafe address is currently being assigned.
Ready	BOOLEAN	The F module is ready to be addressed.
Error	BOOLEAN	An error has occurred, address assignment is aborted.
ModuleStatus	DWORD	Error output and module status
SerialNumber	STRING	Serial number of the interface module ET 200SP

4.2 Call Sequence of the Parameters

The following table gives the call sequence of the parameters of the FB "PROFIsafeAddrAssign".

Table 4-3 Call sequence of the parameters of the FB "PROFIsafeAddrAssign" for F module address assignment

No.	Action	Reaction / Note
1	Control "Enable" to TRUE.	<ul style="list-style-type: none"> "Ready" = TRUE "Busy" = TRUE
2	Control "Identification" to TRUE.	<ul style="list-style-type: none"> F module flashes green "SerialNumber" displays the serial number of the

4 Description of the FB "PROFIsafeAddrAssign"

No.	Action	Reaction / Note
		IM. • "Ready" = FALSE
3	Control (within 30 s) "Confirm" to TRUE.	• "Confirm" = TRUE
4	Control (within 30 s) "Assign" to TRUE.	• F module stops flashing. • LED DIAG lights green. • "BUSY" = FALSE • "DONE" = TRUE A PROFIsafe address has been assigned successfully to the F module.
5	Control of the inputs "Enable", "Identification", "Confirm" and "Assign" to FALSE.	

The following figure shows the time sequence of the parameters of the FB "PROFIsafeAddrAssign".

Figure 4-2 Time sequence of the parameters of the FB "PROFIsafeAddrAssign" for PROFIsafe address assignment of an F module

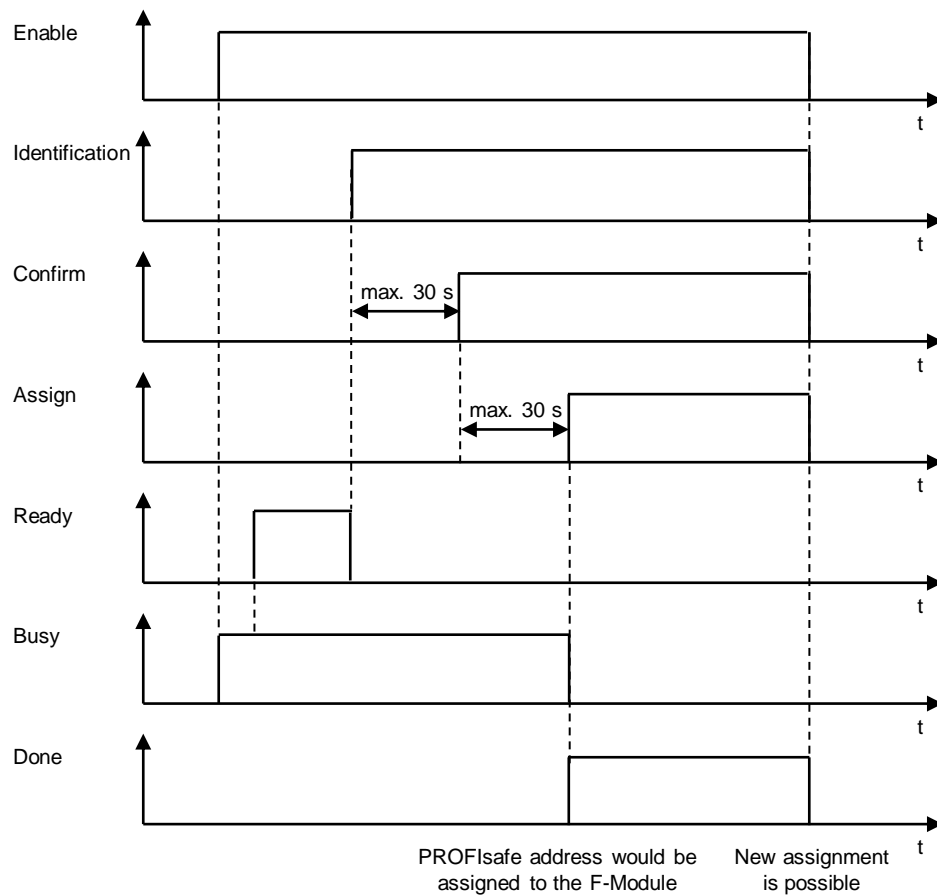

4.3 Error Handling

Address assignment errors lead to the following behavior:

- The output bit "Error" is set.
- The output bits "Busy" and "Ready" are reset.
- The F module is set into the non-addressed status.
- Addressing is reset to the original status.
- An error code for the relevant error is displayed at the "ModuleStatus" output (see section [4.4](#))

A new positive edge implements a new address assignment.

4.4 S7 Diagnostics Messages

Errors and statuses of the F module are output at the "ModuleStatus" output.

Table 4-4 Error codes

STATUS[1]	STATUS[2]	STATUS[3]	STATUS[4]	Explanation
80			00	Error
	90			Block-specific errors
		1x		F source address
		10		The value is outside the value range. Specify a value between 1 and 65534.
		2x		F destination address
		20		The value is outside the value range. Specify a value between 1 and 65534.
		3x		Slot number
		30		The value is outside the value range. Specify a value between 1 and 63.
		4x		Logical initial address/hardware ID of the F module.
		40		The value is outside the value range.
		5x		Diagnostics address of the interface module/hardware ID of the interface module.
		50		The value is outside the value range.
		6x		Bus system
		60		The value is outside the value range. Specify a value between 1 and 2.
		7x		F module
		70		Undefined status
		71		Not ready (code element missing)
		72		Invalid PROFIsafe address (F source address and/or F destination address do not match the hardware configuration)
		8x		User error
		80		Timeout between "Identification" and "Confirm"
		81		Timeout between "Confirm" and "Assign"
		82		The command sequence was not respected.
		83		Input has been reset.
		84		The "Confirm" command is sent by the user although the F module to which the F address is to be assigned is not blinking. Check the configuration and parameters.

4 Description of the FB "PROFIsafeAddrAssign"

STATUS[1]	STATUS[2]	STATUS[3]	STATUS[4]	Explanation
		85		A safety program is on the F-CPU so the F address assignment cannot be carried out.

The following module statuses are possible:

Table 4-5 Module statuses

STATUS[1]	STATUS[2]	STATUS[3]	STATUS[4]	Explanation
00			00	No error
	00			No error
		6x		Module status (without error)
		60		Busy: Address assignment not yet completed.
		61		Addressing of the F module is completed.
		62		The channel status LEDs and the DIAG LED of the F module flash.
		63		Inconsistent PROFIsafe address (F module is not yet addressed).

5 Instructions for Implementing the FB "PROFIsafeAddrAssign"

Prepare an additional memory card (section [5.1](#)) before doing the PROFIsafe address assignment.

The PROFIsafe address assignment is then executed by the triggering of the "Enable", "Identification", "Confirm" and "Assign" bits.

5.1 Instructions for Writing the Memory Card

Note

This document differentiates between two memory cards:

- For assignment of the PROFIsafe address
- For the user program

Unless explicitly expressed otherwise, "memory card" designates the memory card required for assigning the PROFIsafe address.

Copied F-CPU with disabled F-capability

To create the memory card you first copy the F-CPU in the hardware configuration of your STEP 7 project (see following figure):

Figure 5-1 Copied F-CPU of the STEP 7 project

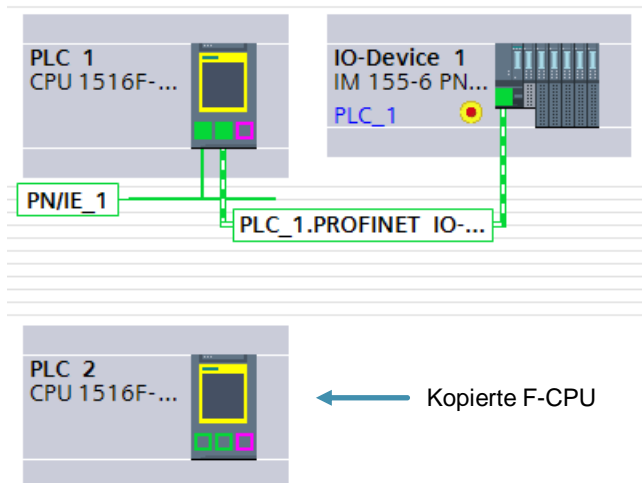

Since the FB "PROFIsafeAddrAssign" can only be executed on an F-CPU with disabled F-capability, you have to do the following for the copied F-CPU:

- Disable the F-capability (see [Figure 5-2](#)).
- Delete all F blocks in the "Program blocks" folder in the project navigation.

Except for the blocks for the configuration control, the standard blocks are not necessary for the PROFIsafe address assignment and should therefore also be deleted.

You call the FB "PROFIsafeAddrAssign" in a cyclic OB (OB1, for example) and parameterize it accordingly.

Figure 5-2 Copied CPU with button for disabling the F-capability

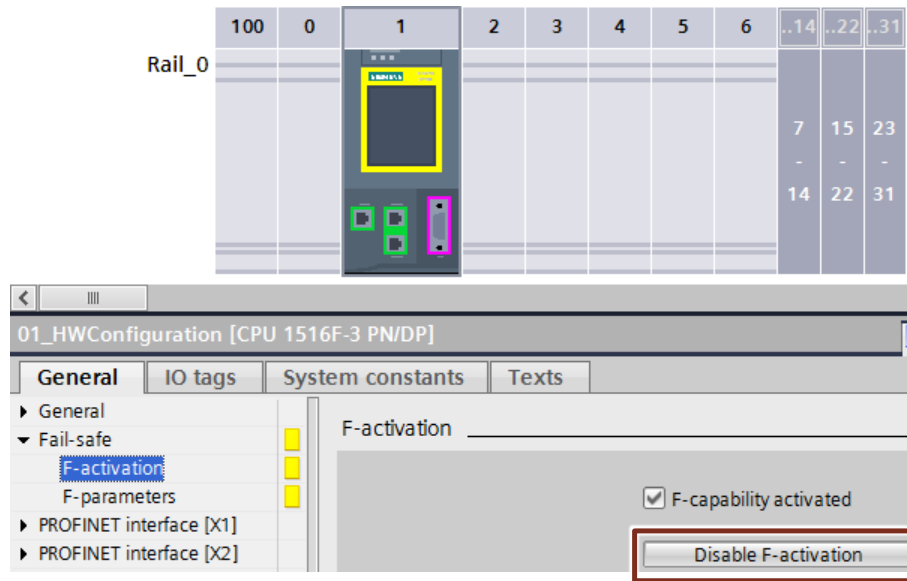

Note

See also [Figure 3-1](#).

Loading the hardware configuration and the software

Proceed as follows:

1. Download the hardware configuration of the F-CPU. ("Download to device > **Hardware configuration**").
2. Download the software of the F-CPU with disabled F-capability ("Download to device > **Software (all)**").

You can now use the memory card to assign the PROFIsafe addresses to the F modules.

5.2 Automatic PROFIsafe Address Assignment via a STEP 7 Program

On the HTML page is a STEP 7 project for downloading. It includes the FB "PROFIsafeAddrAssign". This FB "PROFIsafeAddrAssign" is used for automatic PROFIsafe address assignment (see also section [5.1](#)).

The described utilization of the FB "PROFIsafeAddrAssign" represents just one possibility for automatic PROFIsafe address assignment.



WARNING

Dangerous situations might arise on the machine.

If you do not follow the order of steps given here in section [5.2.1](#) and [5.2.2](#), the F modules might be assigned PROFIsafe addresses not intended for them. This might lead to unexpected reactions on the machine.

Therefore, it is mandatory to keep to the steps and to the order of steps, given in the following instructions.

5.2.1 Conditions for the Machine Manufacturer

As machine manufacturer you can ensure that the F address assignment can be made during commissioning of the series machines without having to be confirmed by the commissioning engineer. In such a case, the conditions of the two cases given below and the resulting measures are to be taken into account.

1. Differently configured stations

The fact that all stations are configured differently with regard to the F modules means that address assignment errors of the stations are discovered in that separate F modules remain passive.

2. Identically configured stations

If the series machines contain identically configured stations you have to specify special test cases with which any mix-up of these stations is discovered.

You have to inform the commissioning engineer in the form of safety requirements of what has to be done in the function test with regard to automatic F address assignment (test cases from Measure 2 (see next page), for example).

Note

If automatic F address assignment is not possible/desired, you can use an HMI for confirmation of the F address assignment. In this case you should follow the instructions given below under "Measure 3".

Order of steps for automatic F address assignment that must be followed for a machine by the machine manufacturer:

1. Create the hardware configuration together with the F modules. In doing so, you should fulfill the following conditions:
 - All stations that contain F modules must be configured differently. No two stations may have F modules of the identical position and type. Proceed as under "Measure 1".
 - If you cannot fulfill this condition, then proceed as under "Measure 2".
 - If you cannot fulfill the condition under "Measure 2", then proceed as under "Measure 3" (next page).
2. Create the user program of the F-CPU that performs the F address assignment.
3. Test the user program.
4. Download the user program with STEP 7 or TIA Portal to a memory card "F address assignment".
5. Write the safety requirements for the commissioning engineer that describe measures for the function test.

Measure 1

All stations that contain F modules must be configured differently. No two stations may have F modules of the identical position and type.

To verify automatic F address assignment it suffices to run a function test that checks that no passive F module is connected to the F-CPU.

This is usually part of the function test of the machine.

The following requirements must be included in the safety requirements for commissioning:

- Perform the function test for all F modules of the F-CPU after each single F address assignment.
- Perform the function test for each instance of the series machine.

It suffices to specify and test function tests for one randomly selectable signal of each of the F modules.

Measure 2

Define the specific function test cases that discover a mix-up of the stations during F address assignment. For example, with multi-axis systems in which each axis is controlled by a module, each separate axis must be moved and the direction verified. These additional function test cases have to be performed in the scope of the function test (safety requirements for the commissioning engineer).

The following requirements must be included in the safety requirements for commissioning:

- Perform the function test for all stations of the F-CPU after each single F address assignment.
- Perform the function test for each instance of the series machine.

It suffices to specify and test function tests for one randomly selectable signal of each of the F modules.

Measure 3

F address assignment with HMI

Write and test the user program for the F address assignment that uses HMI.

The F address assignment must meet the following requirements:

1. Via the HMI have the geographic address (station and slot) of each F module displayed.
2. Have the commissioning engineer confirm that the LED of the F module selected is flashing or have the engineer abort the F address assignment.
3. Have the user perform or abort the F address assignment.
4. Have the confirmation displayed as to whether the F address assignment for the F module was successful or not.
5. Use this procedure consecutively for each separate F module.

Alternatively the serial number can be confirmed to confirm the flashing.

The FB PROFIsafeAddrAssign may only be used for the separate confirmation of each individual F module. In contrast to the TIA Portal, it is not permitted to generally confirm multiple F modules.

Confirm the flashing for F modules of all stations of the F-CPU for which you perform F address assignment with Measure 3.

Perform the confirmation of flashing for each instance of the series machine.

5.2.2 Conditions for the Commissioning Engineer

Proceed as follows for this as commissioning engineer:

Order of steps for each instance of the series machine that must be followed by the commissioning engineer:

1. Insert the "F Address Assignment" memory card and start the F address assignment. This memory card must include the correct hardware configuration of the physical hardware configuration (configuration control/option handling).
2. Remove the "F Address Assignment" memory card and insert the memory card with the safety program into the F-CPU.
3. Now do a function test. If additional safety requirements have been defined, then perform the additional function test cases.



WARNING

If multiple series machines are installed in one plant, the Ethernet network of the plants must be installed so that each instance of the series machine can be separated.

The networks must be separated during F address assignment.

If you cannot separate instances of series machines, each instance needs a separate user program with a different F source address.

5.2.3 General Procedure

Proceed as follows:

1. Slot the memory card from [Figure 3-1](#) into the switched-off F-CPU.
2. Switch on the F-CPU and select the RUN operating mode.
 - If you use automatic PROFIsafe address assignment **without** configuration control, proceed according to section [5.2.5](#).
 - If you use automatic PROFIsafe address assignment **with** configuration control, proceed according to section [5.2.6](#).

5.2.4 Parameter Data Record

User interface "MachineDescription"

To perform automatic PROFIsafe address assignment you need a data block that contains the corresponding necessary parameters for all the F modules to be addressed.

The global data block "MachineDescription" performs this function in the provided TIA Portal projects. This has to be adapted to individual configurations for using the program for automatic PROFIsafe address assignment. A separate "MachineDescription" block has to be created, parameterized and called for each device or slave. For this reason the parameter block in the block projects has the name "MachineDescription IO device_1".

The following figure shows the structure of the DB "MachineDescription IO device_1":

Figure 5-3 structure of the DB "MachineDescription IO device_1"

MachineDescription IO device_1			
	Name	Data type	Start value
1	Static		
2	imHWAddress	HW_IO	264
3	machineFAddressDescription	"typeIMFAddresses"	
4	busSystem	Int	2
5	fSourceAddress	DInt	1
6	SlotArray	Array[1..64] of "typeSlotFAddressAssignment"	
7	SlotArray[1]	"typeSlotFAddressAssignment"	
8	isFModule	Bool	false
9	fDestinationAddress	DInt	0
10	hwIdentifierModule	HW_IO	0
11	SlotArray[2]	"typeSlotFAddressAssignment"	
12	isFModule	Bool	1
13	fDestinationAddress	DInt	65534
14	hwIdentifierModule	HW_IO	270
15	SlotArray[3]	"typeSlotFAddressAssignment"	
16	SlotArray[4]	"typeSlotFAddressAssignment"	

"imHWAddress":

The block begins with the hardware ID

"machineFAddressDescription":

- With "**busSystem**" you have to enter whether it is a PROFIBUS connection (1) or PROFINET connection (2).
- "**fSourceAddress**" specifies the F source address of the F-CPU.

- **"SlotArray"** transfers the remaining module parameters for the F destination address assignment. The index of a "SlotArray" describes the position (slot) of the module in the device/slave.
 - If it is a standard module in a slot:
No action required. The "isFModule" parameter retains the start value (FALSE).
 - If it is an F module in a slot:
 - "isFModule" is changed to TRUE.
 - In "fDestinationAddress" the F destination address is transferred.
 - With "hwIdentifierModule" the hardware ID is transferred.

When you use the configuration control, a "machineOptionDescription" array is added to the "MachineDescription". Since each configuration needs its own data record for the PROFIsafe address assignment, the "machineFAddressDescription" also becomes an array with the same number of elements as the "machineOptionDescription".

User interface "Interface"

The global data block "Interface" is the second user interface. The following figure shows the structure of the DB "Interface":

Figure 5-4 Structure of the DB "Interface"

Interface								
	Name	Data type	Offset	Start value	Retain	Visible in ...	Setpoint	Comment
1	Static				<input type="checkbox"/>	<input type="checkbox"/>	<input type="checkbox"/>	
2	startAutomaticConfiguration	Bool	0.0	false	<input type="checkbox"/>	<input checked="" type="checkbox"/>	<input type="checkbox"/>	Start the automatic machine configuration
3	machineNumber	Int	2.0	1	<input type="checkbox"/>	<input checked="" type="checkbox"/>	<input type="checkbox"/>	Selection of which machine should be config...

"startAutomaticConfiguration"

This variable starts the automatic PROFIsafe address assignment. If the start value is set to TRUE, address assignment begins without any further user intervention directly after the SMC is slotted and the controller goes from STOP -> RUN.

"machineNumber"

When using configuration control, the active configuration is selected with this variable.

5.2.5 PROFIsafe Address Assignment Without Configuration Control

The following figure shows the function sequence and the implementing block structure of the STEP 7 program for assigning the PROFIsafe address if there is no configuration control (all machines are identical).

Figure 5-5 Function and program sequence

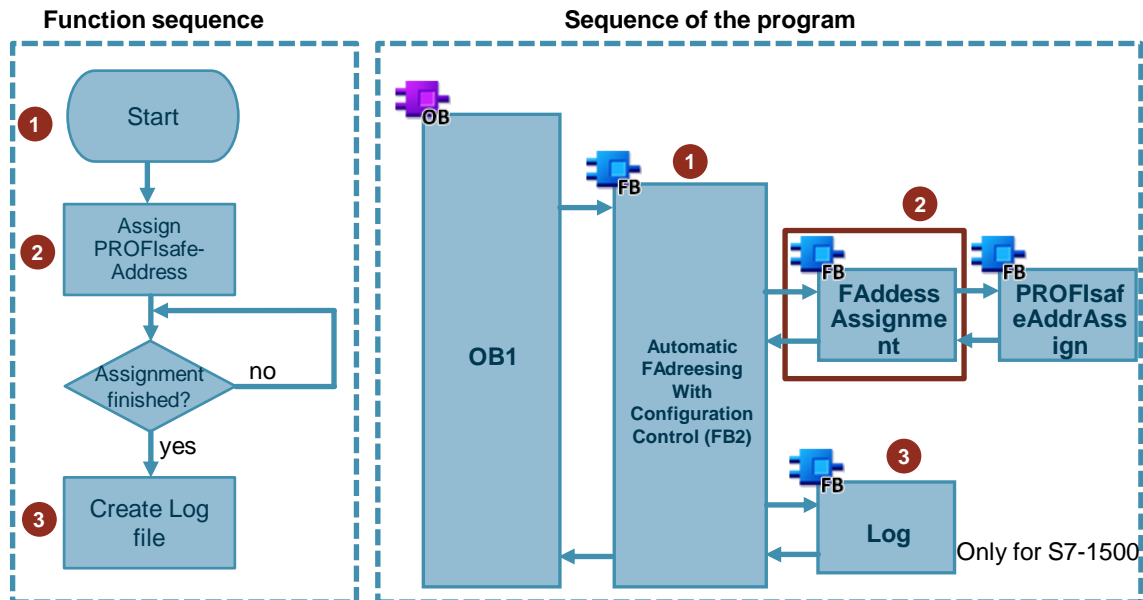

Explanation of figure above:

Table 5-1 Explanation of figure above

No.	Explanation
1	Assignment of the PROFIsafe address starts automatically when the F-CPU is switched on.
2	Assignment of the PROFIsafe address for the F modules is done using the FB "PROFIsafeAddrAssign".
3	Assignment of the PROFIsafe address is logged in a (.csv) log file

This completes the assignment of the PROFIsafe addresses. Now you can replace the slotted memory card with the memory card with your user program.

5.2.6 PROFIsafe Address Assignment With Configuration Control

The following figure shows the function sequence and the implementing block structure of the STEP 7 program for assigning the PROFIsafe address if there is configuration control.

Figure 5-6 Function and program sequence

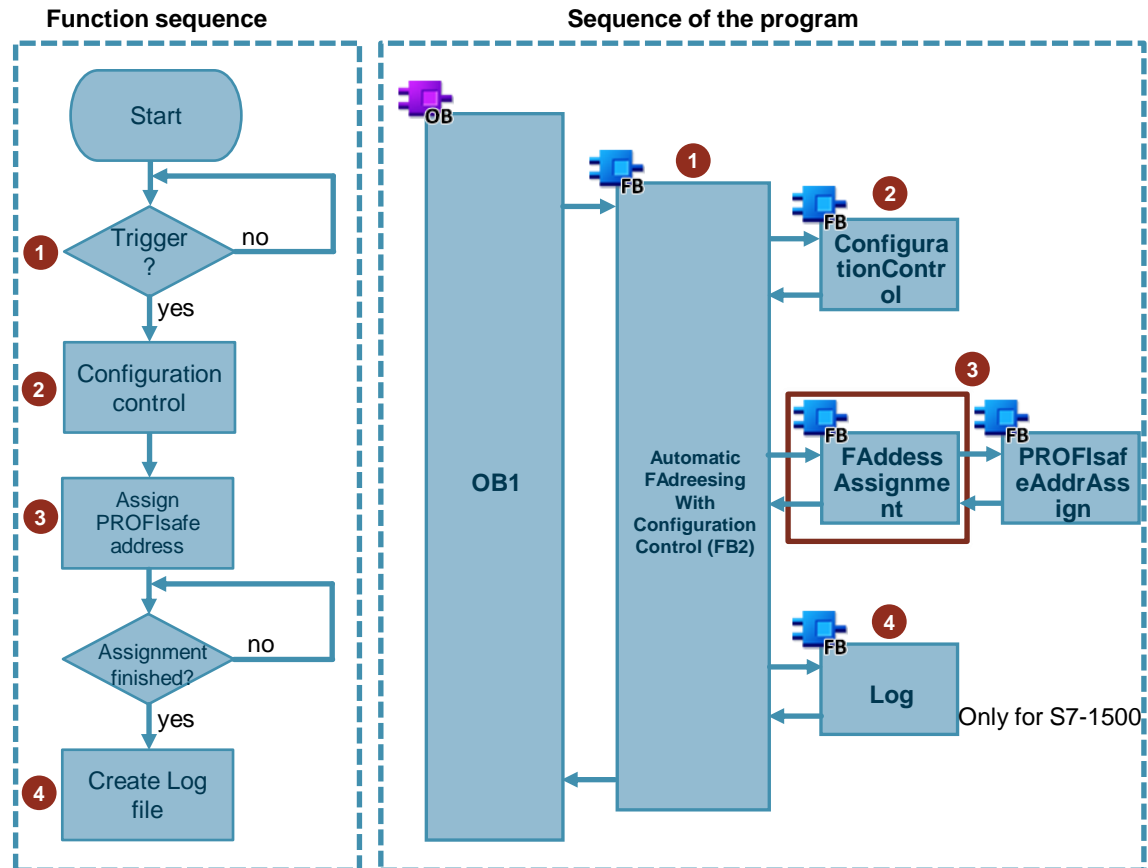

© Siemens AG 2023 All rights reserved

Explanation of figure above:

Table 5-2 Explanation of figure above

No.	Explanation
1	Assignment of the PROFIsafe address starts via a trigger signal (from the web server, HMI, etc.). For this you select "Watch tables" in the web server (or HMI, for example) and select the realized configuration (see Figure 5-7).
2	With configuration control the interface module of the station receives information about the slots where the modules are slotted. Here, it is the actual and not the configured slot that is given.
3	Assignment of the PROFIsafe address for the F modules is done using the FB "PROFIsafeAddrAssign".
4	Assignment of the PROFIsafe address is logged in a (.csv) log file

This completes the assignment of the PROFIsafe addresses. Now you can replace the slotted memory card with the memory card with your user program.

5 Instructions for Implementing the FB "PROFIsafeAddrAssign"

Figure 5-7 "Watch tables" in the web server

Name	Address	Format	Value	Modify value	Comment
"Interface" OptionNumber		Hex	0x	<input type="text"/> Apply	Step 1: Select the machine option
"Interface" StartAutomaticConfiguration		Hex	0x	<input type="text"/> Apply	Step 2: Start the automatic configuration of the machine

Note

You can use an HMI, for example, instead of the web server.

1 Appendix

1.1 Service and support

Industry Online Support

Do you have any questions or need assistance?

Siemens Industry Online Support offers round the clock access to our entire service and support know-how and portfolio.

The Industry Online Support is the central address for information about our products, solutions and services.

Product information, manuals, downloads, FAQs, application examples and videos – all information is accessible with just a few mouse clicks:

support.industry.siemens.com

Technical Support

The Technical Support of Siemens Industry provides you fast and competent support regarding all technical queries with numerous tailor-made offers – ranging from basic support to individual support contracts.

Please send queries to Technical Support via Web form:

support.industry.siemens.com/cs/my/src

SITRAIN – Digital Industry Academy

We support you with our globally available training courses for industry with practical experience, innovative learning methods and a concept that's tailored to the customer's specific needs.

For more information on our offered trainings and courses, as well as their locations and dates, refer to our web page:

siemens.com/sitrain

Service offer

Our range of services includes the following:

- Plant data services
- Spare parts services
- Repair services
- On-site and maintenance services
- Retrofitting and modernization services
- Service programs and contracts

You can find detailed information on our range of services in the service catalog web page:

support.industry.siemens.com/cs/sc

Industry Online Support app

You will receive optimum support wherever you are with the "Siemens Industry Online Support" app. The app is available for iOS and Android:

support.industry.siemens.com/cs/ww/en/sc/2067

1.2 Related literature

Table 1-1

	Topic
\1\	Siemens Industry Online Support https://support.industry.siemens.com
\2\	Download page of this entry https://support.industry.siemens.com/cs/ww/en/view/109748466

1.3 Change documentation

Table 1-2

Version	Date	Modifications
V1.0	12/2017	First version
V2.0	09/2021	Bugfix timing behaviour Extension of validity range (central ET200SP modules and latest F-modules)
V2.1	02/2022	Extension of validity range (S7-1500 Software Controller)
V2.2	07/2023	Exclusion from validity range (ET 200eco PN)