

# SIEMENS

Process Historian -  
Installation Notes

---

1

Process Historian - Release  
Notes

---

2

Process Historian -  
Administration

---

3

## SIMATIC

### Process Historian 2014 SP2 SIMATIC Process Historian

System Manual

05/2017

A5E38560565-AB

## Legal information

### Warning notice system

This manual contains notices you have to observe in order to ensure your personal safety, as well as to prevent damage to property. The notices referring to your personal safety are highlighted in the manual by a safety alert symbol, notices referring only to property damage have no safety alert symbol. These notices shown below are graded according to the degree of danger.

<b>⚠ DANGER</b>
indicates that death or severe personal injury <b>will</b> result if proper precautions are not taken.
<b>⚠ WARNING</b>
indicates that death or severe personal injury <b>may</b> result if proper precautions are not taken.
<b>⚠ CAUTION</b>
indicates that minor personal injury can result if proper precautions are not taken.
<b>NOTICE</b>
indicates that property damage can result if proper precautions are not taken.

If more than one degree of danger is present, the warning notice representing the highest degree of danger will be used. A notice warning of injury to persons with a safety alert symbol may also include a warning relating to property damage.

### Qualified Personnel

The product/system described in this documentation may be operated only by **personnel qualified** for the specific task in accordance with the relevant documentation, in particular its warning notices and safety instructions. Qualified personnel are those who, based on their training and experience, are capable of identifying risks and avoiding potential hazards when working with these products/systems.

### Proper use of Siemens products

Note the following:

<b>⚠ WARNING</b>
Siemens products may only be used for the applications described in the catalog and in the relevant technical documentation. If products and components from other manufacturers are used, these must be recommended or approved by Siemens. Proper transport, storage, installation, assembly, commissioning, operation and maintenance are required to ensure that the products operate safely and without any problems. The permissible ambient conditions must be complied with. The information in the relevant documentation must be observed.

### Trademarks

All names identified by ® are registered trademarks of Siemens AG. The remaining trademarks in this publication may be trademarks whose use by third parties for their own purposes could violate the rights of the owner.

### Disclaimer of Liability

We have reviewed the contents of this publication to ensure consistency with the hardware and software described. Since variance cannot be precluded entirely, we cannot guarantee full consistency. However, the information in this publication is reviewed regularly and any necessary corrections are included in subsequent editions.

# Table of contents

<b>1</b>	<b>Process Historian - Installation Notes</b>	<b>5</b>
1.1	Type of delivery and licenses of Process Historian	5
1.2	System requirements	6
1.2.1	Hardware requirements	9
1.2.2	Security settings	15
1.2.3	Installing Microsoft Message Queuing	16
1.2.4	Installing Microsoft .NET Framework	17
1.3	New installation / Initial installation	18
1.3.1	Installing Process Historian in the PCS 7 environment	19
1.3.1.1	Installing Process Historian for PCS 7	19
1.3.1.2	Setting up Process Historian database	21
1.3.1.3	Installing Process Historian Ready on a PCS 7 Operator Station	23
1.3.2	Installing Process Historian in the WinCC environment	25
1.3.2.1	Installing Process Historian for WinCC	25
1.3.2.2	Setting up Process Historian database	26
1.3.2.3	Installing Process Historian Ready on a WinCC station	28
1.3.3	Preparing Process Historian redundancy	30
1.3.3.1	Installing Process Historian Witness	31
1.4	Installing Process Historian Upgrade	33
1.4.1	Upgrading the Process Historian server	35
1.4.2	Upgrading Process Historian Ready	36
1.4.3	Upgrading the Process Historian as a redundant system	37
1.5	Firewall settings	39
1.6	Integrating Process Historian in a domain	40
<b>2</b>	<b>Process Historian - Release Notes</b>	<b>49</b>
2.1	Release Notes	49
2.2	Service and Support	52
2.2.1	Warnings	52
2.2.2	Customer Support	55
<b>3</b>	<b>Process Historian - Administration</b>	<b>57</b>
3.1	Understanding Process Historian	57
3.1.1	Overview	57
3.1.2	System configurations	59
3.1.3	Storage structure	64
3.1.4	Segmentation - Basics	66
3.1.5	Memory requirement	74
3.1.6	Aggregation - Basics	76
3.2	Setting up the database	78
3.3	Data transfer from PH-Ready to the Process Historian	85

3.4	Commissioning.....	90
3.5	Recovering a database .....	93
3.6	Managing Process Historian .....	95
3.6.1	Management Console - Overview.....	95
3.6.2	Operating states of the Process Historian .....	98
3.6.3	Central overview of the Process Historian Server .....	100
3.6.4	Configuring segments .....	102
3.6.5	Compressing segments .....	104
3.6.6	Backup of segments .....	105
3.6.7	Restoring segments .....	109
3.6.8	Set segments "Offline" .....	110
3.6.9	Backing up the database .....	111
3.6.10	Information on the plant structure of the projects .....	115
3.6.11	Information on the data sources .....	117
3.6.12	Information on the storage system.....	119
3.6.13	Information on the licenses .....	121
3.6.14	Diagnostics of the Process Historian .....	122
3.6.15	Backing up and restoring batch data .....	123
3.7	Migrating archive data from projects.....	129
3.7.1	Overview .....	129
3.7.2	Migrating .....	132
3.7.2.1	CAS project online .....	132
3.7.2.2	CAS project backup .....	136
3.7.2.3	WinCC project online .....	139
3.7.2.4	WinCC project backup .....	142
3.7.2.5	Process Historian project online .....	146
3.8	Using a redundant system .....	149
3.8.1	Redundant system .....	149
3.8.2	Redundancy scenarios .....	151
3.8.3	Setting up Process Historian redundancy.....	156
3.8.4	Initial commissioning of redundant servers.....	158
3.9	Using the Process Historian OPC UA server.....	160
3.9.1	PH OPC UA server - Overview .....	160
3.9.2	Installing the PH OPC UA server .....	162
3.9.3	Security concept of OPC UA.....	164
3.9.4	Configuring the security mechanisms .....	169
3.9.5	Supported OPC UA services and profiles.....	173
3.9.6	Configuration file .....	175
3.9.7	How to configure the PH-OPC UA server .....	176
3.10	Aggregation.....	178
3.10.1	Aggregation functionality.....	178
3.10.2	Calculation of the aggregates .....	181
3.11	Process control messages.....	186
3.12	Information about the operating state on the OS.....	188
3.12.1	Detailed information on the operating state .....	188
<b>Index</b>	.....	<b>191</b>

# Process Historian - Installation Notes

## 1.1 Type of delivery and licenses of Process Historian

### Process Historian type of delivery

Process Historian 2014 SP2 is provided in the following delivery units:

- "Process Historian / Information Server 2014 SP2" DVD
- "PCS 7 V8.2" DVD

### License types

You need the following licenses for operation of a Process Historian system in connection with WinCC or PCS 7:

#### WinCC Licenses

Product	Version	License type	Validity
Process Historian Server	2014	Single	Unlimited
Process Historian Redundancy	2014	Single	Unlimited

#### PCS 7 Licenses

Product	Version	License type	Validity
Process Historian Server	2014	Single	Unlimited
Process Historian Server Redundancy	2014	Single	Unlimited
Process Historian and Information Server	2014	Single	Unlimited
Process Historian Archive-Batch	2014	Single	Unlimited

All licenses are installed on the Process Historian Server computer.

### Connectivity licenses

Additional licenses are required for the following Connectivity functions:

Product	Version	License type	Validity
Process Historian OPC UA Server	2014	Single	Unlimited

## 1.2 System requirements

### Introduction

The installation of SIMATIC Process Historian 2014 SP2 is based on the requirement that all operating system and software configuration requirements listed here have been met.

#### Security settings

You can find information on the firewall and security settings in the section Security settings (Page 15) and in the section "Firewall settings".

#### Hardware requirements

You can find information on the hardware requirements in the section Hardware requirements (Page 9).

### Operating systems

The following Microsoft operating systems are supported:

- Windows Server 2008 R2 SP1 64-bit Standard / Enterprise
- Windows Server 2012 R2 64-bit Standard / Enterprise

#### Operating system languages

Process Historian is approved for the following operating system languages:

- German
- English
- French
- Italian
- Spanish
- Multilingual operating system

The Asian version of Process Historian is approved for the following operating system languages:

- English
- Chinese (Simplified, PRC)
- Japanese
- Multilingual operating system

---

#### Note

Process Historian supports the respective main languages (primary languages) of the operating system languages. For example, English (USA).

---

### Settings for the Windows Server 2008 R2 SP1

In the event of problems with the connection between a client and the server, check the settings for the client licensing mode on the server.

- If your network only has one server, you must select the setting "Per server".  
The "Number of concurrent connections" must equal the number of clients.
- If your network has multiple servers, you must select the setting "Per Seat".

For additional information about licensing, please see the operating system's documentation.

#### NOTICE

##### Process Historian identifies the computer based on the computer SID

The computer SID is a unique security identifier. The Process Historian identifies the WinCC systems based on their computer SID. Computers that have the same computer SID and swap data out to the Process Historian cannot be clearly identified by the Process Historian. This may cause malfunctions on the Process Historian.

When computers are cloned, the computer SID is not adjusted automatically.

The Process Historian/Information Server computer also has to have a unique SID.

### Microsoft Message Queuing services

Process Historian uses the Microsoft Message Queuing services.

This component is part of the operating system. Microsoft Message Queuing may have to be installed separately. Additional information is available in the section "Installing Microsoft Message Queuing (Page 16)"

### Microsoft SQL Server 2014 SP1

Process Historian Server requires the Microsoft SQL Server 2014 SP1 64-bit.  
Process Historian installation automatically includes the SQL Server.

Appropriate user rights must be configured in order to access the data of SQL Server. Read the relevant documentation.

#### SQL Server instance "Historian"

A "Historian" instance with the required settings is created during installation on a Microsoft SQL Server 2014 SP1 . You can change the name of the instance later.

This instance is always installed in English. The language of an SQL Server instance already installed has no influence on this procedure. Existing instances are not affected by the Service Pack.

The existing SQL Server instances that were created with Microsoft SQL Server 2008 remain on the computer. You do not have to remove these instances.

**"Historian" instance after the removal of Process Historian**

The SQL Server instance "Historian" is retained when you remove Process Historian. These must be removed manually for licensing reasons.

**NOTICE**

**Do not change the Windows computer name**

Do not rename the Windows computer after having installed Process Historian.

If you do rename the Windows computer, you must remove and reinstall the SQL Server.

**Do not use the name "HIST" or "HISTORIAN" for the Process Historian**

You cannot use the name "HIST" or "HISTORIAN", because these names are already specified for the SQL Server instance. Using this name would lead to a conflict with the SQL Server and the Database Wizard would not work.

**Operating system update**

It is not permitted to update the operating system while Process Historian Server is running.

To install the update, follow these steps:

1. Shut down the Process Historian Server with the Process Historian Management Console.
2. Install the operating system update.
3. Start the computer again after updating the operating system.

**Virtualization**

The following virtualization systems have been tested:

- Microsoft Hyper-V 2012 R2
- VMware ESXi 5.5 / 6.0

**Requirement**

The performance data of the virtual computers must meet the minimum requirements for the hardware.

You can find additional information about virtual environments with WinCC at the following URL (entry ID=49368181):

- Internet: FAQ (<http://support.automation.siemens.com/WW/view/en/49368181>)



## 1.2.1 Hardware requirements

### Introduction

Before you decide on specific hardware equipment, you must estimate the anticipated number of tags and messages and define how long the data is to be stored in the Process Historian. Based on these numbers, you can determine the necessary hard disk capacity.

For more information, refer to the "Process Historian Administration (<https://support.industry.siemens.com/cs/ww/en/view/109475338>)" manual:

- You can determine the memory requirements of the Process Historian server in the "Memory requirements" section.
- Because Runtime segments take up more space on the hard disk than archive segments, the required hard disk space is also dependent on the configuration of the segments. For basic information on segmentation, refer to the "Segmentation - Basics" section.
- The selection of the hardware also depends on the system configuration. You can determine which system configurations are possible in the "System configurations" section.

The "PH-HWAdvisor" tool calculates the hardware configuration for the Process Historian project-specifically. For more information, please refer to PH-HWAdvisor (<https://support.industry.siemens.com/cs/ww/en/view/109740115>)

If the OS server is used with Process Historian the system partition (C:\) must have a capacity of 250 GB.

**Overview of the configuration limits**

The following assumptions are made regarding the values for the configuration limits:

- The Process Historian was configured with six Runtime segments and one future segment.
- The compression factor is "10".
- The data is available for two years "online" in the Process Historian.
- The calculation of the required memory space is based on the **high** limit of the respective variables.

Configuration limits	Small (S)	Medium (M)	Large (L)	Extra Large (XL)
OS server (redundant)	1	2 - 4	5 - 10	11 - 18
OS client	4	16	40	40
Max. process values/s	1500	6000	15,000	27,000
∅ messages/min	10	40	100	180
Memory space required				
for the process values in TB	1	4	10	18
for the messages in TB	0.04	0.16	0.4	0.7
Configured hard disk memory*)				
for the process values in TB	2	7.2	14.4	21.6
for the messages in TB		0.6	0.9	1.8

\*) The following is taken into account:

- The compression factor may vary.
- The data can be available for more than two years "online" in the Process Historian.
- The capacity of the hard disks is larger than calculated by the operating system.

**Hardware equipment for small configuration limits (S)**

Platform	IPC 847D		
CPU	Xeon E3-1268L v3 (4C/8T, 2.30 GHz, 8 MB cache, TB, VT-d, AMT)		
RAM	32 GB, EEC		
Hard disks	<b>Properties and quantity</b>	<b>Total memory capacity</b>	<b>Use</b>
	1 x 240 GB SSD SATA	240 GB	Operating system and transaction log The SSD hard disk should have two partitions: <ul style="list-style-type: none"> <li>• Partition 1: 100 GB for the operating system and the software</li> <li>• Partition 2: 140 GB for the transaction log</li> </ul> This means that in emergencies the operating system can be restored without losing the transaction log.
	RAID 5, 3 x 1 TB, HDD SAS	2 TB	Complete Process Historian database

With this hardware equipment, you cannot use the following options:

- Process Historian redundancy
- Combined Process Historian and Information Server
- SIMATIC BATCH batch archive

**Hardware equipment for medium configuration limits (M)**

Platform	Fujitsu Primergy RX2560 M1 with Windows Server 2012 R2, Standard Edition		
CPU	Intel® Xeon® processor E5-2643v3 (6C/12T, 3.40 GHz, TLC: 20 MB, Turbo: 3.60 GHz, 9.6 GT/s, Mem bus: 2.133 MHz, 135 W, AVX Base 2.80 GHz, AVX Turbo 3.40 GHz)		
RAM	64 GB, EEC		
Hard disks (18x) 2.5" SAS 12 GB/s	<b>Properties and quantity</b>	<b>Total memory capacity</b>	<b>Use</b>
	RAID 1, 2 x 600 GB	600 GB	Operating system
	RAID 1, 2 x 1.8 TB	1.8 TB	Transaction log
	RAID 1, 2 x 1.8 TB	1.8 TB	Process values (data group 0)
	RAID 1, 2 x 1.8 TB	1.8 TB	Process values (data group 1)
	RAID 1, 2 x 1.8 TB	1.8 TB	Process values (data group 2)
	RAID 1, 2 x 1.8 TB	1.8 TB	Process values (data group 3)
	RAID 1, 2 x 600 GB	600 GB	Messages
	RAID 1, 2 x 600 GB	600 GB	General data
RAID 1, 2 x 1.8 TB	1.8 TB	Information Server database	

The maximum duration of absence of the redundant partner is 20 days.

1.2 System requirements

**Hardware equipment for large configuration limits (L)**

Platform	Fujitsu Primergy RX2560 M1 with Windows Server 2012 R2, Standard Edition		
CPU	2x Intel® Xeon® processor E5-2643v3 (6C/12T, 3.40 GHz, TLC: 20 MB, Turbo: 3.60 GHz, 9.6 GT/s, Mem bus: 2.133 MHz, 135 W, AVX Base 2.80 GHz, AVX Turbo 3.40 GHz)		
RAM	64 GB, EEC		
Hard disks (24x) 2.5" SAS 12 GB/s	<b>Properties and quantity</b>	<b>Total memory capacity</b>	<b>Use</b>
	RAID 1, 2 x 600 GB	600 GB	Operating system
	RAID 10, 4 x 1.8 TB	3.6 TB	Transaction log
	RAID 10, 4 x 1.8 TB	3.6 TB	Process values (data group 0)
	RAID 10, 4 x 1.8 TB	3.6 TB	Process values (data group 1)
	RAID 10, 4 x 1.8 TB	3.6 TB	Process values (data group 2)
	RAID 10, 4 x 1.8 TB	3.6 TB	Process values (data group 3)
	RAID 1, 2 x 900 GB	900 GB	Messages
	RAID 1, 2 x 900 GB	900 GB	General data
RAID 1, 2 x 1.8 TB	1.8 TB	Information Server database	

The maximum duration of absence of the redundant partner is 20 days.

**Hardware equipment for extra large configuration limits (XL)**

Platform	Fujitsu Primergy RX2560 M1 with Windows Server 2012 R2, Standard Edition		
CPU	2x Intel® Xeon® processor E5-2643v3 (6C/12T, 3.40 GHz, TLC: 20 MB, Turbo: 3.60 GHz, 9.6 GT/s, Mem bus: 2.133 MHz, 135 W, AVX Base 2.80 GHz, AVX Turbo 3.40 GHz)		
RAM	128 GB, EEC		
Hard disks (32x) 2.5" SAS 12 GB/s	<b>Properties and quantity</b>	<b>Total memory capacity</b>	<b>Use</b>
	RAID 1, 2 x 1.8 TB	1.8 TB	Operating system
	RAID 1, 2 x 1.8 TB	5.4 TB	Transaction log
	RAID 10, 6 x 1.8 TB	5.4 TB	Process values (data group 0)
	RAID 10, 6 x 1.8 TB	5.4 TB	Process values (data group 1)
	RAID 10, 6 x 1.8 TB	5.4 TB	Process values (data group 2)
	RAID 10, 6 x 1.8 TB	5.4 TB	Process values (data group 3)
	RAID 1, 2 x 1.8 TB	1.8 TB	Messages
	RAID 1, 2 x 1.8 TB	1.8 TB	General data

With this hardware equipment, you cannot use the following options:

- Process Historian redundancy
- Combined Process Historian and Information Server
- SIMATIC BATCH batch archive

**Note**

You can expand the scale in regard to performance and the database size by using a Storage Area Network (SAN).

## Overview of the configuration limits with BATCH data

Configuration limits	Medium (M)	Large (L)
OS server (redundant)	2 - 4	5 - 10
OS client	16	40
Max. process values/s	6000	15,000
∅ messages/min	40	100
Memory space required (refers to only one redundant BATCH server)		
for the process values in TB	4	10
for the messages in TB	0.16	0.4
for the BATCH messages <sup>*)</sup>	2	2
Configured hard disk memory		
for the process values in TB	7.2	14.4
for the messages in TB	3.6	3.6

\*) 60 recipe steps/min require 1 TB for the BATCH messages

## Medium configuration limits with BATCH data and Information Server (M)

Platform	Fujitsu Primergy RX2560 M1 with Windows Server 2012 R2, Standard Edition		
CPU	Intel® Xeon® processor E5-2643v3 (6C/12T, 3.40 GHz, TLC: 20 MB, Turbo: 3.60 GHz, 9.6 GT/s, Mem bus: 2.133 MHz, 135 W, AVX Base 2.80 GHz, AVX Turbo 3.40 GHz)		
RAM	64 GB, EEC		
Hard disks (22x) 2.5" SAS 12 GB/s	<b>Properties and quantity</b>	<b>Total memory capacity</b>	<b>Use</b>
	RAID 1, 2 x 600 GB	600 GB	Operating system
	RAID 1, 2 x 1.8 TB	1.8 TB	Transaction log
	RAID 1, 2 x 1.8 TB	1.8 TB	Process values (data group 0)
	RAID 1, 2 x 1.8 TB	1.8 TB	Process values (data group 1)
	RAID 1, 2 x 1.8 TB	1.8 TB	Process values (data group 2)
	RAID 1, 2 x 1.8 TB	1.8 TB	Process values (data group 3)
	RAID 10, 4 x 1.8 TB	3.6 TB	Messages
	RAID 1, 2 x 600 GB	600 GB	General data
	RAID 1, 2 x 1.8 TB	1.8 TB	Information Server database
RAID 1, 2 x 1.8 TB	1.8 TB	BATCH data	

With this hardware equipment, you cannot use the following options:

- Process Historian redundancy

1.2 System requirements

**Medium configuration limits with BATCH data and Process Historian redundancy (M)**

Platform	Fujitsu Primergy RX2560 M1 with Windows Server 2012 R2, Standard Edition		
CPU	Intel® Xeon® processor E5-2643v3 (6C/12T, 3.40 GHz, TLC: 20 MB, Turbo: 3.60 GHz, 9.6 GT/s, Mem bus: 2.133 MHz, 135 W, AVX Base 2.80 GHz, AVX Turbo 3.40 GHz)		
RAM	64 GB, EEC		
Hard disks (22x) 2.5" SAS 12 GB/s	<b>Properties and quantity</b>	<b>Total memory capacity</b>	<b>Use</b>
	RAID 1, 2 x 600 GB	600 GB	Operating system
	RAID 10, 4 x 1.8 TB	3.6 TB	Transaction log
	RAID 1, 2 x 1.8 TB	1.8 TB	Process values (data group 0)
	RAID 1, 2 x 1.8 TB	1.8 TB	Process values (data group 1)
	RAID 1, 2 x 1.8 TB	1.8 TB	Process values (data group 2)
	RAID 1, 2 x 1.8 TB	1.8 TB	Process values (data group 3)
	RAID 10, 4 x 1.8 TB	3.6 TB	Messages
	RAID 1, 2 x 600 GB	600 GB	General data
RAID 1, 2 x 1.8 TB	1.8 TB	BATCH data	

**Large configuration limits with BATCH data and Information Server (L)**

Platform	Fujitsu Primergy RX2560 M1 with Windows Server 2012 R2, Standard Edition		
CPU	2x Intel® Xeon® processor E5-2643v3 (6C/12T, 3.40 GHz, TLC: 20 MB, Turbo: 3.60 GHz, 9.6 GT/s, Mem bus: 2.133 MHz, 135 W, AVX Base 2.80 GHz, AVX Turbo 3.40 GHz)		
RAM	128 GB, EEC		
Hard disks (32x) 2.5" SAS 12 GB/s	<b>Properties and quantity</b>	<b>Total memory capacity</b>	<b>Use</b>
	RAID 1, 2 x 600 GB	600 GB	Operating system
	RAID 1, 2 x 1.8 TB	1.8 TB	Transaction log
	RAID 10, 4 x 1.8 TB	3.6 TB	Process values (data group 0)
	RAID 10, 4 x 1.8 TB	3.6 TB	Process values (data group 1)
	RAID 10, 4 x 1.8 TB	3.6 TB	Process values (data group 2)
	RAID 10, 4 x 1.8 TB	3.6 TB	Process values (data group 3)
	RAID 10, 4 x 1.8 TB	3.6 TB	Messages
	RAID 1, 2 x 900 GB	900 GB	General data
	RAID 1, 2 x 1.8 TB	1.8 TB	Information Server database
RAID 10, 4 x 1.8 TB	3.6 TB	BATCH data	

With this hardware equipment, you cannot use the following options:

- Process Historian redundancy

## Redundant Process Historian Server

A redundant Process Historian system consists of symmetrically configured servers for master (principal) and standby (mirror) operation.

<b>NOTICE</b>
<b>Redundant connection</b>
It is advisable to create a dedicated redundancy connection between the redundant Process Historian servers <b>with a minimum bandwidth of 1 GB.</b>

The Witness Server component is designed for scenarios with automatic redundancy failover. It is also installed on an additional computer of the system, depending on availability an Information Server or WinCC Server.

### 1.2.2 Security settings

#### Introduction

Observe the security settings for Process Historian Server and Process Historian Ready (PH Ready) during configuration:

- The security settings of the firewall are the basis of the security concept.
- Additional Windows services, such as PH-Ready or CCCAPHServer and MSMQ, must be configured via the operating system with user rights.

#### Firewall security settings for the Process Historian Server

The necessary security settings for the locally installed Windows firewall for operation of the Process Historian Server are automatically adapted during installation.

For more information on the security settings of the firewall, refer to the section "Firewall settings".

#### User permission for the PH-Ready service

The Process Historian Ready component (PH-Ready) is configured using the configuration wizard for the service "CCCAPHServer".

You can find a description for user permission in the sections:

- Installing Process Historian Ready on a PCS 7 Operator Station (Page 23)
- Installing Process Historian Ready on a WinCC station (Page 28)

### 1.2.3 Installing Microsoft Message Queuing

#### Introduction

Process Historian uses the Microsoft Message Queuing services. This component is part of the operating system. MS Message Queuing is however not included in the standard Windows installation and must be installed separately if required.

The Windows installation CD is required to complete the installation.

#### Procedure for Windows Server 2008

1. Start the Server Manager.
2. Right-click on "Features" in the navigation area and select "Add features".
3. Activate the "Message Queuing > Message Queuing Services > Message Queuing Server" option.
4. Click "Install".

#### Procedure for Windows Server 2012

1. Start the Server Manager.
2. Click on "Add roles and features".
3. Click "Server selection" in the navigation area. Ensure that the current computer is selected.
4. Click "Features" in the navigation area.
5. Activate the "Message Queuing > Message Queuing Services > Message Queuing Server" option.
6. Click "Install".



## 1.2.4 Installing Microsoft .NET Framework

### Procedure

1. Select "Start > Administrative Tools > Server Manager".
2. Right-click the "Features" menu item.
3. Select the "Add Features" command in the shortcut menu.
4. Activate the ".Net Framework 4.6.2" option.
5. Click the "Add Required Features" button.
6. Click "Next".
7. Click "Install".

### Result

.Net Framework 4.6.2 has been installed.

## 1.3 New installation / Initial installation

### Introduction

The installation of the Process Historian is described in this section.

The installation depends on the environment in which the Process Historian is used.

This means that you have to follow the installation instructions for use with PCS 7, WinCC, or in a redundant system.

### User rights for the Process Historian

To install the Process Historian, you require the following Windows authorizations:

- Administrator

### Procedure - Overview

Installation comprises the following steps:

1. Installing the Process Historian server on a computer
2. Creating a Process Historian database
3. Installing the Process Historian Ready component and configuring the PH-Ready service:
  - On a WinCC station
  - On a PCS 7 Operator Station (OS)

The installation of the Process Historian Server is finished when all processes are completed and the system is restarted.

### Commissioning of the Process Historian

During initial commissioning, you must start the Process Historian before the WinCC servers. The Process Historian must also be in the "Active" operating state before WinCC Runtime is started. When the Process Historian is started after the WinCC server, the WinCC server may not set up the necessary message queues correctly.

## 1.3.1 Installing Process Historian in the PCS 7 environment

### 1.3.1.1 Installing Process Historian for PCS 7

#### Introduction

Depending on the configuration, you have various configuration options:

Configuration	Installation
Combined Process Historian/Information Server	<ul style="list-style-type: none"> <li>• Program package "Process Historian and Information Server" on the Process Historian/Information Server</li> <li>• Program "Process Historian Ready Component 2014 SP2" on the OS servers</li> </ul>
Dedicated Process Historian/Information Server	<ul style="list-style-type: none"> <li>• Program package "Process Historian" on the Process Historian OPC UA Server</li> <li>• Program "Process Historian OPC UA 2014 SP2" on the Process Historian OPC UA Server</li> <li>• Program "Process Historian Ready Component 2014 SP2" on the OS servers</li> <li>• Program package "Information Server" on the Information Server</li> </ul>
Redundant Process Historian with Information Server as Witness	<ul style="list-style-type: none"> <li>• Program package "Process Historian" on the Process Historian Master (Principal) and on the Process Historian Standby (Mirror)</li> <li>• Program "Process Historian Ready Component 2014 SP2" on the OS servers</li> <li>• Program "Information Server 2014 SP2" and "Process Historian Witness 2014 SP2" on the Information Server</li> </ul>
Process Historian/Information Server and SIMATIC BATCH	<ul style="list-style-type: none"> <li>• Program package "Process Historian and Information Server" on the Process Historian/Information Server</li> <li>• Program "Information Server - BATCH Options V8.2" on the Information Server</li> <li>• Program "Information Server - MS Office AddIn 2014 SP2" on the Information Server-Client, when the client is used as MS Office-Client.</li> <li>• Program "Process Historian Ready Component 2014 SP2" on the OS servers</li> </ul>
Referenced OS Single Station with Process Historian/Information Server	<ul style="list-style-type: none"> <li>• Program package "Process Historian and Information Server" on the Process Historian/Information Server</li> <li>• Program "Process Historian Ready Component 2014 SP2" on the referenced OS Single Station</li> <li>• The base OS Single Station must be redundant if you use a Process Historian in this configuration. You can use eight OS stations in total.</li> </ul>

The installation of Process Historian is described in this section. Proceed in the same way with the other installation options.

#### Note

##### Restart during installation

Several restarts are requested during installation. These restarts must be executed when they are requested and not at a later time.

## Requirement

- Observe the installation notes of the PCS 7 product DVD.
- You have installed Microsoft Message Queuing (MSMQ).

## Procedure for installing Process Historian

1. Start the setup for PCS 7 V8.2 from the DVD "PCS 7 V8.2"
2. Follow the instructions of the installation wizard.  
Read the License Agreement and the Open Source License Agreement.
3. If necessary, enter the following information in the "User information" dialog:
  - User
  - Associated organization
4. Select the required "Type of installation":
  - Package installation
  - Custom installation
5. In the category "Archiving and Reporting", select the program package "Process Historian" for the package installation or the program "Process Historian Server 2014 SP2" for the user-defined installation.
6. If required, select additional components in the "Programs" dialog.
7. Observe the Microsoft SQL Server License Agreement.
8. Confirm the changes to the system settings in the "System settings" dialog. The firewall is configured automatically.
9. Start installation.
10. To complete the installation, restart the system.
11. The Process Historian database installation wizard is started, with which you can set up the Process Historian database.

## Result

The Process Historian Server is installed on the computer.

To learn how to set up the Process Historian database, refer to the section "Setting up Process Historian database (Page 21)".

---

### Note

The product documentation is available in the installation path under "\\Siemens\Process Historian\Documentation".

---

## Additional information

You can also find more information in the following FAQs for PCS 7 (<https://support.industry.siemens.com/cs/ww/en/view/66579062>)

- Installation and commissioning of Process Historian/Information Server in the PCS 7 environment
- Setting up a new Process Historian with an existing Process Historian database
- Integration of Process Historian/Information Server in a domain
- Moving a Process Historian/Information Server from Workgroup A to Workgroup B

### 1.3.1.2 Setting up Process Historian database

#### Introduction

After the completion of the setup for PCS 7, the database installation wizard is opened. Use the wizard to set up the Process Historian database.

Before you set up the database, get the necessary information from the "Process Historian Administration (<https://support.industry.siemens.com/cs/ww/en/view/109475338>)" manual:

- About the basics of segmentation in the "Segmentation - Basics" section.
- About the basics of the storage structure in the "Storage structure" section.

A detailed guide to setting up the database is available in the "Process Historian Administration" manual on the "Creating a database" page.

---

#### Note

##### Overwriting an existing Process Historian database

When you recreate an existing database with the same name, the existing database is overwritten.

---

## Basic procedure

- You have to select which drives are used for Process Historian.
- The database installation wizard analyzes your system and uses the information for the installation process.
- If the system does not find the SQL Server "HISTORIAN" instance, select the SQL Server instance on which the Process Historian database is configured.
- You have to select the server mode in which the Process Historian is operated and configured:
  - As single-user system
  - As redundant system. You install Process Historian on the Master (Principal) server and on the Standby (Mirror) server.
- If you use a redundant system, the Process Historian Redundancy Service is configured subject to the specification of the user and the password.
- An overview lists the default settings of the configured Process Historian database.
- When necessary, the default settings can be changed as follows:
  - Specify anticipated data load of process values and messages
  - Specify the segmentation of the database
  - Modify the storage paths for data files and log files
  - Specify the Process Historian server as SIMATIC BATCH repository

---

### Note

Only modify the default settings if you are familiar with the segmentation and storage structure.

---

### 1.3.1.3 Installing Process Historian Ready on a PCS 7 Operator Station

#### Introduction

With the following OS installation options, the Process Historian Ready (PH-Ready) component is automatically installed at the same time:

- OS server for Process Historian
- Maintenance Station for Process Historian
- OS single station for Process Historian

After the installation, configure the PH-Ready service with the service configuration wizard.

Use the following DVD to install PH-Ready at a later time:

- DVD "PCS 7 V8.2"

---

#### Note

##### Restart during installation

Several restarts are requested during installation. These restarts must be executed when they are requested and not at a later time.

---

#### Requirement

- Microsoft Message Queuing (MSMQ) is installed.
- The user under which Process Historian was installed is created on the computer.

#### Installing Process Historian Ready

1. Run the setup for PCS 7 V8.2.
2. Follow the instructions of the installation wizard.  
Read the License Agreement and the Open Source License Agreement.
3. In the "Server" category, select the program package "OS Server für Process Historian" or the program "Process Historian Ready Component 2014 SP2" under "Archiving and Reporting".
4. Confirm the changes to the system settings in the "System settings" dialog. The firewall is configured automatically.
5. Start installation.
6. To complete the installation, reboot the system.
7. Configure the PH-Ready service using the service configuration wizard.

## Configuring the PH-Ready service

After the computer has been restarted, start the configuration wizard for the "CCCAPHServer" service.

You use the service configuration wizard to specify the user under which the PH-Ready service is executed. The user should be the same user who installed the Process Historian.

The user is automatically a member of the "SIMATIC HMI" user group.

---

### Note

#### Update installation of PCS 7

When you upgrade the PCS 7 version on the OS, you next have to re-configure the PH-Ready service.

---

### Procedure

1. Start the configuration wizard from the "Siemens Automation" program group:  
SIMATIC > PH-Ready > PH-Ready Configuration
2. Select the "Run with user credentials" option in the "New security setting" area.
3. Enter the user under which Process Historian was installed. Enter the password.  
The user must have been created on the OS.
4. Complete the configuration of the "CCCAPHServer" service with "Finish".

You can run the configuration wizard at any time to modify the access rights.

---

### Note

**The specified passwords must be identical on the computers for a user.**

Make sure that all passwords specified for a user are identical on the following systems:

- WinCC OS/PCS 7 OS
- Process Historian server
- Witness server

Make sure to notice any changes to passwords.

---

## Result

The Process Historian Ready component is installed on the computer.



## 1.3.2 Installing Process Historian in the WinCC environment

### 1.3.2.1 Installing Process Historian for WinCC

Use the following DVD to install Process Historian in the WinCC environment:

- "Process Historian / Information Server 2014 SP2" DVD

---

#### Note

##### Restart during installation

Several restarts are requested during installation. These restarts must be executed when they are requested and not at a later time.

---

#### Requirement

- Microsoft Message Queuing (MSMQ) is installed.
- Microsoft.NET Framework 4.6.2 is installed.

#### Procedure

1. Run the setup for Process Historian / Information Server 2014 SP2.
2. Follow the instructions of the installation wizard.  
Read the License Agreement and the Open Source License Agreement.
3. In the category "Process Historian", select the "Process Historian Server 2014 SP2" program package.
4. If required, select additional components in the "Programs" dialog.
5. Observe the Microsoft SQL Server License Agreement.
6. Confirm the changes to the system settings in the "System settings" dialog. The firewall is configured automatically.
7. Start installation.
8. To complete the installation, restart the system.
9. The Process Historian database installation wizard is started, with which you can set up the Process Historian database.

## Result

The Process Historian Server is installed on the computer.

To learn how to set up the Process Historian database, refer to the section "Setting up Process Historian database (Page 26)".

---

### Note

The product documentation is available in the installation path under "\Siemens\Process Historian\Documentation".

---

## Additional information

You can also find more information in the following FAQs for WinCC (<https://support.industry.siemens.com/cs/en/en/view/106264271>)

- Basics and system configuration of PH and IS
- Installation and commissioning of PH and IS, including a section on error correction

### 1.3.2.2 Setting up Process Historian database

#### Introduction

The database installation wizard is opened after the setup for WinCC has been completed. Use the wizard to set up the Process Historian database.

Before you set up the database, get the necessary information from the "Process Historian Administration (<https://support.industry.siemens.com/cs/ww/en/view/109475338>)" manual:

- About the basics of segmentation in the "Segmentation - Basics" section.
- About the basics of the storage structure in the "Storage structure" section.

A detailed guide to setting up the database is available in the "Administration" manual on the "Creating a database" page.

---

### Note

#### Overwriting an existing Process Historian database

When you recreate an existing database with the same name, the existing database is overwritten.

---

## **Basic procedure**

- You have to select which drives are used for Process Historian.
- The database installation wizard analyzes your system and uses the information for the installation process.
- If the system does not find the SQL Server "HISTORIAN" instance, select the SQL Server instance on which the Process Historian database is configured.
- You have to select the server mode in which the Process Historian is operated and configured:
  - As single-user system
  - As redundant system. You install Process Historian on the Master (Principal) server and on the Standby (Mirror) server.
- If you use a redundant system, the Process Historian Redundancy Service is configured subject to the specification of the user and the password.
- An overview lists the default settings of the configured Process Historian database.
- When necessary, the default settings can be changed as follows:
  - Specify anticipated data load of process values and messages
  - Specify the segmentation of the database
  - Modify the storage paths for data files and log files
  - Specify the Process Historian server as SIMATIC BATCH repository

---

### **Note**

Only modify the default settings if you are familiar with the segmentation and storage structure.

---

### 1.3.2.3 Installing Process Historian Ready on a WinCC station

#### Introduction

As of WinCC V7.4 SP1 you have the following possibilities for installing the component Process Historian Ready (PH-Ready):

- Via the "Process Historian / Information Server 2014 SP" DVD
- Via the WinCC Explorer

Via the WinCC Explorer you can also download updates for PH-Ready when the Process Historian makes downloads available.

After the installation, configure the PH-Ready service using the service configuration wizard.

---

#### Note

##### Restart during installation

Several restarts are requested during installation. These restarts must be executed when they are requested and not at a later time.

---

#### Requirement

- Microsoft Message Queuing (MSMQ) is installed.
- The user under which the Process Historian was installed is created on the computer.

#### Installing Process Historian Ready via the DVD

1. Start the setup for Process Historian / Information Server 2014 SP.
2. Select the product language.
3. Follow the instructions of the installation wizard.  
Read the License Agreement and the Open Source License Agreement.
4. In the category "Process Historian", select the "Process Historian Ready Component 2014 SP" program package.
5. Start installation.
6. To complete the installation, reboot the system.
7. Configure the PH-Ready service using the service configuration wizard.

#### Installing Process Historian Ready and updates via the WinCC Explorer

1. Select the menu entry "Extras / Add-on download" in WinCC Explorer.
2. Enter the computer name of the Process Historian in the dialog. After clicking the "Update" button the available files are displayed for downloading in the list.
3. Select a file and click the "Download" button.  
PH-Ready or the update is downloaded to the specified destination path.

## Configuring the PH-Ready service

After the computer has been restarted, start the configuration wizard for the "CCCAPHServer" service.

Use the service configuration wizard to specify the user under which the PH-Ready service is executed. The user should be the same user who installed the Process Historian.

The user is automatically a member of the "SIMATIC HMI" user group.

### Procedure

1. Start the configuration wizard from the "Siemens Automation" program group:  
SIMATIC > PH-Ready > PH-Ready Configuration
2. Select the "Run with user credentials" option in the "New security setting" area.
3. Enter the user under which the Process Historian was installed. Enter the password.

The user must have been created on the OS.

4. Complete the configuration of the "CCCAPHServer" service with "Finish".

You can run the configuration wizard at any time to modify the access rights.

---

### Note

**The specified passwords must be identical on the computers for a user.**

Make sure that all passwords specified for a user are identical on the following systems:

- WinCC OS/PCS 7 OS
- Process Historian server
- Witness server

Make sure to notice any changes to passwords.

---

## Result

The Process Historian Ready component is installed on the computer.

### 1.3.3 Preparing Process Historian redundancy

A redundant Process Historian system is based on the Microsoft SQL Server Mirroring.

To use this service, install a Process Historian Master (principal) as redundant server and a Process Historian Standby (mirror).

Set up a third system to check availability of the redundancy: The witness. If you have installed a SIMATIC Information Server in your system, for example, you can use this PC as witness.

For more information on configuration, initial commissioning and operation, refer to the "Redundant system" section in the "Process Historian Administration (<https://support.industry.siemens.com/cs/ww/en/view/109475338>)" manual.

#### Installation of a redundant Process Historian

Installation of a redundant system comprises the following steps:

1. Master (Principal): Installing and setting up the Process Historian server. The Process Historian Redundancy Service is configured during the setup.
2. Standby (Mirror): Installing and setting up the Process Historian server. The Process Historian Redundancy Service is configured during the setup.
3. Witness: Installing Process Historian Witness and configuring Process Historian Redundancy Service (see section "Installing Process Historian Witness (Page 31)")
4. On the Process Historian Management Console in the "Redundancy" dashboard, configure the redundant system using the redundancy configuration wizard.

The detailed procedure is available in the "Setting up Process Historian Redundancy" section of the "Process Historian Administration" manual.

5. Installing the Process Historian Ready component and configuring the PH-Ready service:
  - On a WinCC station. Additional information in: Installing Process Historian Ready on a WinCC station (Page 28)
  - On a PCS 7 Operator Station (OS). Additional information in: Installing Process Historian Ready on a PCS 7 Operator Station (Page 23)

### **1.3.3.1 Installing Process Historian Witness**

To monitor the status of the redundant Process Historian system, install Process Historian Witness on a third PC in addition to the master (principal) and standby (mirror).

The procedures for PCS 7 and WinCC differ, depending on the use case.

#### **Requirement**

- One of these systems is installed on the PC:
  - PCS 7 OS Server for Process Historian
  - PCS 7 OS Single Station
  - WinCC server
  - WinCC single-user system
  - SIMATIC Information Server

## Procedure

1. Run the setup.  
Use the corresponding DVD depending on the configuration:
  - PCS 7:  
DVD "PCS 7 V8.2"
  - WinCC:  
DVD "Process Historian / Information Server 2014 SP2"
2. Carry out the installation.  
Follow the procedure for installation of the Process Historian Server:
  - Installing Process Historian for PCS 7 (Page 19)
  - Installing Process Historian for WinCC (Page 25)
3. Select under "Custom installation":
  - DVD "PCS 7 V8.2":  
"Archiving and Reporting" > "Process Historian Witness 2014 SP2" program
  - DVD "Process Historian / Information Server 2014 SP2"  
"Options" > "Process Historian Witness 2014 SP2" program package
4. To complete the installation, reboot the system.
5. After the restart, the service configuration wizard, which configures the Process Historian Redundancy Service, is automatically opened. In the wizard, enter a user that has been granted access rights to the Process Historian database of the redundant computer.
6. Follow the wizard instructions and click "Next".
7. In the "Service configuration" dialog, enter a user and a password in the "New security setting" area of the service configuration.  
Click "Next".
8. The "Overview" dialog displays a summary of the configuration.  
Verify your entries and complete the process with "Finish".

## Result

The "Process Historian Witness" component is installed and the Process Historian Redundancy Service is configured.

For more information on the configuration and the operation, refer to the "Redundant system" section in the "Process Historian Administration (<https://support.industry.siemens.com/cs/ww/en/view/109475338>)" manual.



## 1.4 Installing Process Historian Upgrade

### Introduction

You can upgrade a previous version of the Process Historian to the current version using the upgrade installation.

With an upgrade, you update all computers in the Process Historian system. Therefore, install the upgrade on all computers on which the following components are installed:

- Process Historian
- PH-Ready component of the Process Historian

<b>NOTICE</b>
<b>Backing up existing data</b>
Generate a backup of the existing database before you upgrade the Process Historian server.

### Procedure of the upgrade installation

1. Upgrading the Process Historian server and updating the Process Historian database
2. Upgrading PH-Ready to the PCS 7 OS and/or the WinCC PC

To upgrade a server, follow the instructions in the "Upgrading the Process Historian server (Page 35)" section.

To upgrade a redundant system, follow the instructions in the "Upgrading the Process Historian as a redundant system (Page 37)" section.

1.4 Installing Process Historian Upgrade

Depending on the installed version, the upgrade installation may need to take place via intermediate versions, as shown in the following table:

From version	Via version	Via version	Via version	To version
V8.0	2013 Update 6	2014 SP1 Update 1	2014 SP2	2014 SP2 Update 3
V8.0 Update 1	2013 Update 6	2014 SP1 Update 1	2014 SP2	2014 SP2 Update 3
2013	2013 Update 6	2014 SP1 Update 1	2014 SP2	2014 SP2 Update 3
2013 Update 1	2013 Update 6	2014 SP1 Update 1	2014 SP2	2014 SP2 Update 3
2013 Update 2	2013 Update 6	2014 SP1 Update 1	2014 SP2	2014 SP2 Update 3
2013 Update 3	2013 Update 6	2014 SP1 Update 1	2014 SP2	2014 SP2 Update 3
2013 Update 4	2013 Update 6	2014 SP1 Update 1	2014 SP2	2014 SP2 Update 3
2013 Update 5	2013 Update 6	2014 SP1 Update 1	2014 SP2	2014 SP2 Update 3
2013 Update 6	-	2014 SP1 Update 1	2014 SP2	2014 SP2 Update 3
2013 Update 7	-	2014 SP1 Update 1	2014 SP2	2014 SP2 Update 3
2014	-	-	2014 SP2	2014 SP2 Update 3
2014 Update 1	-	-	2014 SP2	2014 SP2 Update 3
2014 SP1	-	-	2014 SP2	2014 SP2 Update 3
2014 SP1 Update 1	-	-	2014 SP2	2014 SP2 Update 3
2014 SP2	-	-	-	2014 SP2 Update 3
2014 SP2 Update 1	-	-	-	2014 SP2 Update 3
2014 SP2 Update 2	-	-	-	2014 SP2 Update 3

**System behavior after the upgrade installation is complete**

- The applications (services) are automatically restarted after restart of the computer.
- The Process Historian Management Console is started in the background on the Process Historian server.

**Process Historian status and licensing status**

While the upgrade is being installed, the Process Historian and the management console are not available.

**Database: Access rights during installation**

The access rights of the registered user to the SQL server of the database are temporarily revoked during the upgrade installation. Clients, too, do not have access to the database during the upgrade.

## 1.4.1 Upgrading the Process Historian server

### Introduction

Depending on the configuration, use the corresponding, latest version of the PCS 7 DVD, WinCC DVD or update download to upgrade a Process Historian server.

After the installation, the Process Historian database is updated using the database installation wizard.

<b>NOTICE</b>
<b>Backing up existing data</b>
Generate a backup of the existing database before you upgrade the Process Historian server.

### Procedure

1. To close the application, shut down the Process Historian in the "Process Historian Management" dashboard.  
  
Additional information on changing the operating state is available in the "Central overview of the Process Historian Server" section in the "Administration" manual.
2. Run the setup.
3. Follow the instructions of the installation wizard.
4. Carry out the installation.
5. To complete the installation, reboot the system. After the upgrade installation, the Process Historian database installation wizard is started. Databases from predecessor versions are migrated by means of this wizard without modification of the interfaces.
6. Follow the instructions of the database installation wizard to update the existing data. As soon as the database is updated, a window appears with an overview of actions already performed.
7. To complete the installation, reboot the system.

### Result

The Process Historian server has been upgraded and the Process Historian database has been updated.

---

#### Note

When you upgrade the plant from PCS 7 8.0.2.x to PCS 7 V9.0 during runtime, you may have to restart the Process Historian after successful upgrade of all OS servers so that pending recoveries can be executed.

---

## 1.4.2 Upgrading Process Historian Ready

After the upgrade installation of the Process Historian server, upgrade the other computers of the Process Historian system:

- On the WinCC stations
- On the PCS 7 operator stations (OS)

Perform an upgrade of Process Historian Ready (PH-Ready).

---

### Note

#### Restart during installation

Several restarts may be requested during installation. These restarts must be executed when they are requested and not at a later time.

---

### Requirement

- A predecessor version of Process Historian Ready is installed.

### Installing Process Historian Ready

1. Run the setup. Use the corresponding DVD or setup file depending on the configuration.
2. Follow the instructions of the installation wizard.  
Read the License Agreement and the Open Source License Agreement.
3. To complete the installation, reboot the system.

### Result

The Process Historian Ready component is installed on the computer.

### 1.4.3 Upgrading the Process Historian as a redundant system

#### Overview of the procedure

To ensure a correct upgrade process, you must observe the following sequence for upgrading the redundant Process Historian system:

1. Create backup of the existing database.
2. Make sure that the Process Historian is enabled on the redundant computers.
3. Switch off the witness.
4. Perform an upgrade installation on the Master (Principal) and the Standby (Mirror).  
You can update the two computers one after the other or both at the same time. In the procedure described below, first the Master and then the Standby is upgraded.
5. Database migration on the Master (Principal) and Standby (Mirror) using the database installation wizard. The database installation wizard also configures the Process Historian Redundancy Service.
6. Start and upgrade the Witness. Configure the Process Historian Redundancy Service .
7. Upgrade PH-Ready on the PCS 7 OS and WinCC PCs.
8. Test the redundancy switching.

---

#### Note

##### Restart during installation

Several restarts may be requested during installation. These restarts must be executed when they are requested and not at a later time.

---

#### Requirement

- You have created a backup of the existing database.
- Process Historian is enabled on the Master (Principal), Standby (Mirror) and Witness.
- No external segments are linked. Therefore, check in the "Backup/Restore" dashboard to see whether restored segments are connected. Set these segments to offline prior to the upgrade installation.

#### Procedure

1. Shut down the computer on which the Witness is running.  
The Witness remains switched off and is restarted only after the upgrade from Master (Principal) and Standby (Mirror).  
PCS 7 OS and WinCC PCs with link to the Process Historian can remain in operation.
2. Perform the upgrade installation on the Master (Principal).

1.4 Installing Process Historian Upgrade

3. To complete the installation, reboot the Master (Principal).  
The Process Historian Management Console is started and checks the system.
4. The database installation wizard is started and migrates the data. If the database installation wizard is not started automatically, exit the Process Historian Management Console and reboot the console.  
This process can take a long time. The duration of the migration depends on the size of the database and the number of connected archive segments. Do not interrupt the migration.  
The database installation wizard also configures the Process Historian Redundancy Service.
5. Check the displayed summary of executed actions after migration.  
The Master (Principal) is upgraded and ready for operation.  
The connection to the PCS 7 OS and WinCC PCs is established. The data collected in the meantime is transferred to the Process Historian database.
6. Perform the upgrade installation on the Standby (Mirror).
7. To complete the installation, reboot the Standby (Mirror).  
The Process Historian Management Console is started and checks the system.
8. The database installation wizard is started and updates the configuration for database access. The database installation wizard also configures the Process Historian Redundancy Service.  
The Standby (Mirror) is upgraded and ready for operation.  
The Process Historian database is automatically mirrored from the Master (Principal) to the Standby (Mirror).
9. Start the computer on which the Witness is installed.
10. Perform the upgrade installation on the Witness.  
Configure the Process Historian Redundancy Service.
11. Perform the upgrade of PH-Ready on the PCS 7 OS and WinCC PCs.

## Result

The redundant Process Historian system is updated.

---

### Note

#### Process Historian status and licensing status

Before the restart, the status is shown as "Undefined" in the 'Process Historian status' area of the Management Console.

The license is declared as "Invalid license" in the 'Licensing status' area.

After the restart, the status is synchronized again with the update.

---

## 1.5 Firewall settings

During installation, the firewall settings for the locally installed Windows firewall are automatically adjusted.

These ports must remain available if you need to use an additional firewall between the OS server and Process Historian.

Make sure that firewall features that make checks at application level are adjusted, if necessary. For example, the "RPC Filter" feature must be disabled for the SIEMENS Application Firewall.

### Firewall security settings

Process Historian Server and PH-Ready require the following settings for operation:

Name	Protocol	Port
PH Discovery Services	TCP	5048
PH Network Discovery	UDP	137
PH Repository Services	TCP	5053
PH Redundancy Services	TCP	60000
PH WCF Message Queue Service (Redundancy Maintenance Service)	TCP	60001
PH WCF Message Queue Service (SQL Mirroring Setup)	TCP	60002
PH WCF Message Queue Service (Maintenance Service)	TCP	60003
PH SQL-Mirroring Port (TCP)	TCP	5022
PH SQL-Mirroring Port (UDP)	UDP	5022
PH SQL-Server Monitor Port	UDP	1434
PH SQL-Server Port	TCP	3723
PH LLMNR-UDP-In	UDP	5355
OPC UA Local Discovery Server	TCP	Any port
OPC UA Local Discovery Server	TCP	Any port
PH RPC for MSMQ	TCP	135

## 1.6 Integrating Process Historian in a domain

This section includes examples of and references to infrastructure management.

In the following example, a Process Historian is transferred from a workgroup to a domain.

---

### Note

Process Historian is generally enabled for operation in a domain or workgroup.

Operation in a domain must be agreed upon with the domain administrator. In the case of user-specific guidelines, remove the PC from the domain before you install Microsoft Message Queuing and Microsoft SQL Server. Log on to the computer concerned locally with administrator rights. Perform the installation. You can reassign the WinCC computer to the domain once the installation is successfully completed.

Note however that domain group policies and restrictions in the domain may also hinder operation. If these restrictions cannot be overcome, operate the WinCC computer in a workgroup.

---

### Integrating Process Historian:

You can use the Process Historian in workgroups or in domains:

- To operate a Process Historian in a workgroup, install the Process Historian as administrator in this workgroup.
- To operate a Process Historian in a domain, install the Process Historian as administrator in this domain.

### Installation of the Process Historian

The example below describes how to transfer the Process Historian to a domain once the Process Historian has been installed in a workgroup.

#### Installation in a workgroup

Installation of the Process Historian in a workgroup is described in the FAQ "Installing and Commissioning of Process Historian/Information Server in the PCS 7 Environment (<http://support.automation.siemens.com/WW/view/en/66579062>)".



## Preparation

For the login information of the services on the OS to remain the same, these services must be operated by a domain or workgroup whose password is not changed. This includes the following services:

- CCCAPHServer Service
- Process Historian Redundancy Service
- Witness server

If the passwords are changed, however, the login information of these services must be changed accordingly on the corresponding OS server; this server must then be restarted.

Note the following conditions:

- If you integrate an OS system in a domain, you must register the domain user who logs on in additional local groups.
- To simplify administration and installation, create a domain user as local administrator on the OS server and the Process Historian.
- The domain user who is logged on to the operating system must not be the same user who starts the CCCAPHServer service.
- The domain user who starts the CCCAPHServer service must have the appropriate authorizations in the SQL Server of the Process Historian. Add this user to the local administrator group of the OS system.

**Configuration example**

The example below shows the transfer of a workgroup installation to a domain installation. For security reasons, the operating system login for the OS server and the Process Historian should only have local user authorizations.

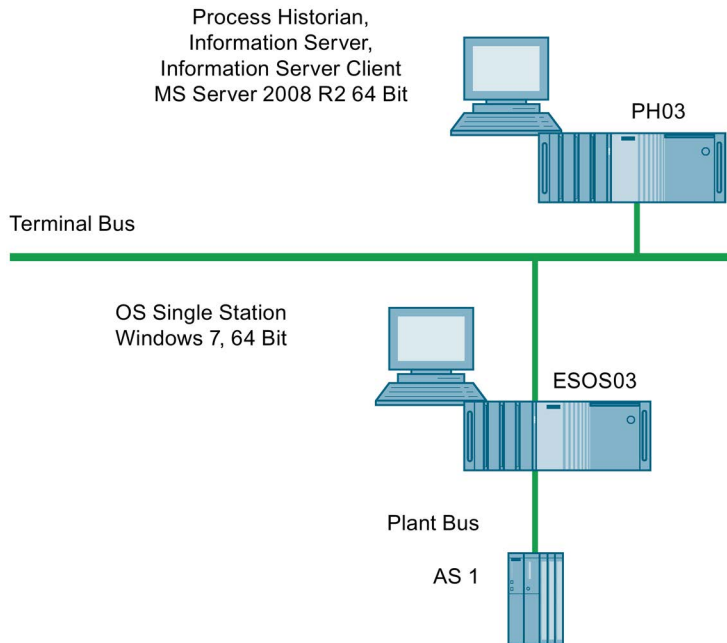

Function	Name	Comment
Domain	pcs7sv.local	
OS server	ESOS03	
Process Historian / Information Server	PH03	Process Historian and Information Server are running on the same physical PC
Operating system login for OS server and Process Historian	OSUserDom	The login has local user authorizations.
CCCAPHServer login for OS server	PHReadyUserETest	The login requires local administrator authorization on the OS server.

## Integrating ES/OS single station in a domain

In this example, an ES/OS single station is integrated in a domain. We are using the Windows 7 operating system in the 64-bit version for the description.

1. Open the "System Properties" window.
2. Click "Edit".

The "Changing the computer name or the domain" window opens.

3. Enter the name of the domain in the "Member of" text box of the domain option.
4. Click "OK" to confirm the change.

The change is applied and the window is closed.

## Enter domain user

The domain user must be entered in the local SIMATIC HMI group and in the local administrator group for the operating system login. Follow the steps below:

1. Open the "Computer Management" window.
2. Open the list of local groups.
3. Open the shortcut menu of the "SIMATIC HMI" user group.
4. Select the "Properties" of the "SIMATIC HMI" user group.
5. In the "Properties" window, click "Add".

The "Select user" window opens.

6. Click "Paths".

You are prompted to authenticate yourself for access to the domain in the "Windows Security" window.

7. Enter your user name and your password in the text boxes. Confirm your entries.

A window containing the domain paths is opened.

8. Select the required domain path and confirm your selection.

A window for selection of users, computers, service accounts and groups opens.

9. In the text box, enter the OS user name you want to log on to the operating system on the OS during runtime. Confirm your selection.

The selection window closes.

The "Properties" window of the "SIMATIC HMI" user group opens.

The new user has been added in the "Members" field.

10. Close the process with "OK".

## 1.6 Integrating Process Historian in a domain

### Local groups for the domain user

Also enter the domain user logged on to the operating system of the ES/OS single station as described above in the following groups:

- User
- Siemens TIA Engineer
- SIMATIC NET

Then restart the ES/OS single station.

### Configuring the CCCAPHServer service

The CCCAPHServer service must be started by a domain user. Follow the steps below:

1. Open the "Computer Management" window.
2. Navigate to "Services and Applications>Services".  
The list of services is displayed.
3. Open the shortcut menu of the "CCCAPHServer" service.
4. Select "Properties".  
The "CCCAPHServer Properties" windows opens.
5. Click the "Logon" tab.
6. Select the "This account" option.
7. Click "Browse".  
The "Select user or service account" window opens.
8. Click "Paths".  
A window containing the domain paths is opened.
9. Select the domain name under which the user who is to start the CCCAPHServer service has been created.
10. Confirm your selection with "OK".  
A window for selection of users, computers, service accounts and groups opens.
11. Enter the domain user in the text box and confirm your entry.  
The "CCCAPHServer Properties" windows opens again.
12. Select the "This account" option.
13. Enter the password of the user in the text box and repeat your entry in the text box underneath.
14. Click "OK" to close your input.  
The windows are closed.

### **Result**

A service window indicates the successful completion of the process.

Another service window indicates that the new entries will be activated with a restart of the service.

### **Restart**

1. Open the Computer Management again.
2. Open the shortcut menu of the CCCAPHServer.
3. Select "Restart".

The CCCAPHServer service restarts.

The new entries have been applied.

## **Entering CCCAPHServer users**

Enter the CCCAPHServer user in the local administrator group:

1. Open the "Computer Management" window.
2. Select "Local Users and Groups>Groups".
3. Open the shortcut menu of the "CCCAPHServer" user group.
4. Click "Properties".
5. The "Properties" window of the "CCCAPHServer" user group opens.
6. Click "Add".

The "Select user" window opens.

7. Click "Paths".

You are prompted to authenticate yourself for access to the domain in the "Windows Security" window.

8. Enter your user name and your password in the text boxes. Confirm your entries with "OK".

A window containing the domain paths is opened.

9. Select the required domain path and confirm your selection with "OK".

A window for selection of users, computers, service accounts and groups opens.

10. Enter the user name for the CCCAPHServer domain in the text box. Click "OK" to confirm your entries.

The selection window closes.

The "Properties" window of the "CCCAPHServer" user group opens.

The new user has been added in the "Members" field.

11. Click "OK" to close the process.

---

**Note**

**Domain user logon**

The domain user must not be logged on to the OS operating system during runtime.

---

### Integrating OS server in a domain

The procedure is the same as for the ES/OS single station. Unlike with the ES/OS single station, you also enter the domain user who is logged on to the operating system in the following groups:

- User
- SIMATIC HMI
- SIMATIC NET

### Integrating combined Process Historian / Information Server in a domain

To integrate a combined Process Historian/ Information Server in a domain, follow these steps:

1. Open the "System Properties" window.
2. Click "Edit".

The "Changing the computer name or the domain" window opens.

3. Enter the name of the domain in the "Member of" text box of the domain option.
4. Click "OK" to confirm your entries.

The change is applied and the window is closed.

### Creating SQL Server login for domain user

To create an SQL Server login for a domain user who is entered for a CCCAPHServer, follow these steps:

1. Go to "Start > Microsoft SQL Server 2014 > SQL Server Management Studio" and open the SQL Server Management Studio.
2. Connect to the SQL instance "HISTORIAN" by clicking "Connect".
3. Within the SQL Server, navigate to the "Security\Logins" folder.
4. Click the "Logins" folder.
5. Create a new login on the SQL Server for the domain user who also starts the CCCAPHServer service on the OS.
6. Click "OK" to confirm your entries.
7. Open the "Login" shortcut menu.
8. Select "New Login".

9. Click "Browse" in the "Login Now" window.
10. Click "Paths" in the "Select user or group" window.  
You are prompted to authenticate yourself for access to the domain in the "Windows Security" window.
11. Enter your user name and your password in the text boxes. Confirm with "OK".  
A window containing the domain paths is opened.
12. Select the required domain path. Confirm your selection with "OK".  
A window for selection of users, computers, service accounts and groups opens.
13. Enter the user name in the input box. Click "OK" to confirm your entries.  
The selection window closes.

**Result:**

The new user name is displayed in the "Login Now" window.  
The new login is entered in the login list of the computer management.

**Grant login authorizations**

You grant the corresponding authorizations for the SQL Server login in the SQL Server.

1. To do so, open the properties of the newly created SQL Login.
2. Change to the "Server Roles" tab.  
The "Login properties PCS7SV\PHReadyUserETest" window opens.
3. Change to the "User Mapping" tab.
4. Map all project databases to the new SQL Server login. Project databases start with DB\_Master\_XY.
5. Select "public" and "db\_owner" as "Database role membership".
6. Do the same for the databases "HistorianStorage", "ReportServer&HISTORIAN" and "ReportServer&HISTORIANTempDB".

The Process Historian services are still started with "Local System".

## Redundant Process Historian

1. Start the Process Historian Redundancy service with the new domain user.

Screenshot as example (temporary):

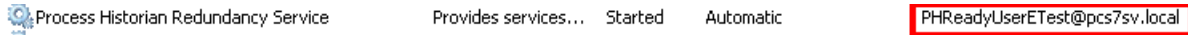

2. An SQL login with corresponding user assignment must be created for the domain user on the Process Historian server as well as on the Process Historian Witness.

## User authorizations on the Process Historian

1. The "OS UserDom" operating system login only has user authorization on the Process Historian. This means the user cannot open the SQL Server Management Studio. The database is therefore protected from manipulations using the SQL Server Management Studio.
2. If the operating system login only has user authorization on the Process Historian, the Process Historian Management console is not opened automatically at restart. A restart with administrator authorization is necessary to open the Process Historian Management console.
  - Go to "Start > Siemens Automation > SIMATIC > Process Historian > Process Historian Management Console".
  - Right-click "Process Historian Management Console".
  - Click "Start as administrator" in the shortcut menu. Authenticate yourself as administrator.
3. To start the Process Historian Management console automatically after a restart, add the domain user to the local administrator group.



# Process Historian - Release Notes

## 2.1 Release Notes

### Content

These release notes contain important information for the SIMATIC Process Historian.

The statements in these release notes take precedence over information provided in the manuals and in the online help.

Read these release notes carefully as they contain useful information.

### Upgrading Process Historian ahead of the OS servers during ongoing operations

You must first upgrade the Process Historian Server to Process Historian before:

- Upgrading a PCS 7 plant to the latest version of PCS 7 during operation
- and at the same time upgrade the operating systems of the OS servers, e.g. Server 2008 to Server 2012
- or try to replace the hardware of the OS servers.

It is only when the Process Historian is in the "Active" operating state and all the pending restorations have been executed that you can begin to upgrade the OS servers.

If necessary, start the restoration more than once if any data gaps become obvious. You can also start the restoration manually via the Management Console or the PH tray symbol.

When you upgrade the plant from PCS 7 8.0.2.x to PCS 7 V9.0 during runtime, you may have to restart the Process Historian after successful upgrade of all OS servers so that pending recoveries can be executed.

## Database Installation Wizard

The Database Installation Wizard has several command line options.

---

### Note

These optional parameters are only used by the Process Historian system and are not intended for use by administrators.

---

The following options are **not** released for use:

Option	Description
/silent	Used to start a database installation without user input.
/update	Used to update an existing database to a new version.
/silentupdate	Used to update an existing database to a new version without user interaction.
/classic	Allows use in compatibility mode < 2014 SP2.
/configservices	Configures the Process Historian services on the Mirror.
/recovery	Starts the assistant for restoring a database backup.

## Tools that are not supported in the Process Historian

### LogViewer.exe

As of version PH 2014 SP2, a tool which is not supported is installed to analyze log files from Process Historian and Information Server.

The tool may only be used by suitably trained personnel (support, hotline, ...). During the analysis of many or very large log files, the tool consumes a large amount of main memory, which can impair the mode of operation of the system.

### SetBackupActivityMS.exe

As of version PH 2014 SP2 Update 2, a tool is installed which disables specific maintenance functions. You are only allowed to start the program when requested to do so by the hotline.

### ProcessDataMigrator with expanded functionality

The "ProcessDataMigrator" program can be called with the "-E" parameters which offer an expanded functionality.

The expansion is intended for test purposes only and you are only allowed to start the program when requested to do so by the hotline.

### **Increase of handles on the Process Historian server**

If you notice an increase of the handles on the Process Historian server, install the following fix from the page <https://support.microsoft.com/en-us/kb/2847346> (<https://support.microsoft.com/en-us/kb/2847346>).

### **WinCC ServiceMode on Windows Server 2008 R2 SP1 64 Bit: Autostart settings**

If you are running the OS server for Process Historian on Windows Server 2008 R2 SP1, you must adjust the autostart settings.

Select the start type setting "Automatic (delayed start)" for the "CCCAPHServer" service under "Services" in the computer management.

### **Work environment: Mixing domains and work groups**

Process Historian does not support operation in a work environment in which domains and work groups are mixed.

### **Initializing communication between WinCC and Process Historian**

The communication between a WinCC server or PCS 7 OS and the Process Historian server by means of Microsoft Message Queuing (MSMQ) is initialized when you open the project.

If the Process Historian computer cannot be reached when you open the project in the network, if the computer is turned off, for example, the MSMQ connection is not established.

In this case, close the WinCC project. Ensure that the Process Historian server is accessible. Then, reopen the WinCC project so that the connection to the Process Historian server is initialized.

## 2.2 Service and Support

### 2.2.1 Warnings

#### Safety information

##### Warning notice system

This manual contains notices you must observe to ensure your personal safety and to prevent damage to property. Notices referring to your personal safety are highlighted in the manual by a safety alert symbol; notices referring to property damage only have no safety alert symbol. The warning notices shown below are graded according to the degree of danger.

 <b>DANGER</b>
indicates that death or severe personal injury will result if proper precautions are not taken.

 <b>WARNING</b>
indicates that death or severe personal injury may result if proper precautions are not taken.

 <b>CAUTION</b>
indicates that minor personal injury may result if proper precautions are not taken.

<b>NOTICE</b>
indicates that property damage may result if proper precautions are not taken.

##### Note

indicates important information about the product and its use or a specific section of the documentation to which you should pay particular attention.

If more than one degree of danger is present, the warning notice representing the highest degree of danger will be used. A warning notice of injury to persons with a safety alert symbol may also include a warning relating to property damage.

## Qualified personnel

The product/system described in this documentation may be operated only by personnel qualified for the specific task in accordance with the relevant documentation, in particular its warning notices and safety information. Qualified personnel are those who, based on their training and experience, are capable of identifying risks and avoiding potential hazards when working with these products/systems.

### Proper use

Note the following:

 <b>WARNING</b>
<b>Proper use of Siemens products</b> Siemens products may only be used for the applications described in the catalog and in the relevant technical documentation. If products and components from other manufacturers are used, these must be recommended or approved by Siemens. Proper transport, storage, installation, assembly, commissioning, operation and maintenance are required to ensure that the products operate safely and without any problems. The permissible ambient conditions must be adhered to. The information in the relevant documentation must be observed.

## Trademarks

All names identified by ® are registered trademarks of Siemens AG. The remaining names in this publication may be trademarks whose use by third parties for their own purposes could violate the rights of the owner.

## Security information

Siemens provides products and solutions with industrial security functions that support the secure operation of plants, systems, machines and networks.

In order to protect plants, systems, machines and networks against cyber threats, it is necessary to implement – and continuously maintain – a holistic, state-of-the-art industrial security concept. Siemens' products and solutions only form one element of such a concept.

Customers are responsible for preventing unauthorized access to their plants, systems, machines and networks. Systems, machines and components should only be connected to the enterprise network or the Internet if necessary and only to the extent necessary and with appropriate protective measures (e.g. use of firewalls and network segmentation) in place.

Additionally, Siemens' guidance on appropriate security measures should be taken into account. For more information about industrial security, please visit

- <http://www.siemens.com/industrialsecurity>

Siemens' products and solutions undergo continuous development to make them more secure. Siemens strongly recommends applying product updates as soon as they are available and always using the latest product versions. Using versions that are obsolete or are no longer supported can increase the risk of cyber threats.

To stay informed about product updates, subscribe to the Siemens Industrial Security RSS Feed under

- <http://www.siemens.com/industrialsecurity>

### Disclaimer of liability

We have reviewed the contents of this publication to ensure consistency with the hardware and software described. However, since variance cannot be precluded entirely, we cannot guarantee full consistency. However, the information in this publication is reviewed regularly and any necessary corrections are included in subsequent editions. Suggestions for improvement are welcomed.

Information in the online documentation is more binding than that in the manuals and PDF files.

Observe the Release Notes and Installation Notes. Information in the Release Notes and Installation Notes is more binding than that in the manuals and online help.

### Copyright © Siemens AG 2017

All rights reserved

The reproduction, transmission or use of this document or its contents is not permitted without express written authorization. Offenders will be held liable for payment of damages. All rights, including rights created by patent grant or registration of a utility or design, are reserved.

Siemens AG

Division Digital Factory

SIMATIC Human Machine Interfaces

P.O. Box 4848

D-90026 Nuremberg, Germany

## 2.2.2 Customer Support

### Customer Support and Technical Support

You can reach the SIMATIC hotlines at the times specified in the following table. The SIMATIC hotline employees speak German and English. The Authorization hotline offers French, Italian or Spanish customer support in addition to German and English.

### Technical support

Nuremberg	(GMT +1:00)
Service Hours	Monday - Friday, 8:00 to 17:00 (CET/CEST)
Phone	+49 (0)911 895 7222
Fax	+49 (0)911 895 7223
E-mail	<a href="http://www.siemens.com/automation/support-request">http://www.siemens.com/automation/support-request</a>

An overview of the Technical Support is available at the following URL:

- <http://support.automation.siemens.com/WW/view/en/16605032>

### Automation Value Card (AVC)

The Automation Value Card (AVC) provides extended Technical Support and is available 24 hours every day of the week. Information on the AVC can be found at the following URL:

- <http://support.automation.siemens.com/WW/view/en/21981898>

## SIMATIC Customer Online Support

### Service and Support

An overview of the support offering for our products is available at the following URL:

- <http://www.siemens.com/automation/service&support>

In Product Support, for example, you will find downloads of firmware updates, service packs and useful utilities.

Online Help is available so that you can successfully use the Support offering. Open the Online Help by selecting the corresponding button on the Internet site or at the following URL:

- [http://support.automation.siemens.com/WW/support/html\\_76/help/Online\\_Hilfe.htm](http://support.automation.siemens.com/WW/support/html_76/help/Online_Hilfe.htm)

### WinCC FAQs

Online Support with information on FAQs (Frequently Asked Questions) may also be found at the following URL:

- <http://support.automation.siemens.com/WW/view/en/56732738/133000>

### Technical Forum

The Technical Forum supports exchange with other SIMATIC users. It is available at the following URL:

- [http://www.siemens.de/automation/csi\\_en/forum](http://www.siemens.de/automation/csi_en/forum)

### Technical documentation for SIMATIC products

You can find a guide to the technical documentation provided for individual SIMATIC products and systems at the following URL:

- <http://www.siemens.com/simatic-tech-doku-portal>

### Contact person database

To contact your local agent, search our contact database at the following URL:

- <http://www.automation.siemens.com/partner/index.asp?lang=en>

## Product Information

### SIMATIC Products

Go to the following URL for additional information about SIMATIC products:

- <http://www.siemens.com/simatic>



# Process Historian - Administration

## 3.1 Understanding Process Historian

### 3.1.1 Overview

#### Process Historian

The SIMATIC Process Historian is the central, high-performance archiving system based on the Microsoft SQL Server.

You can archive all process data and messages from the following sources on the central Process Historian Server in real-time:

- WinCC V7
- PCS 7 Operator Station (OS)
- SIMATIC BATCH
- External OPC UA-Server

The data may originate from different projects. Access to the historical data is transparent for the clients.

#### Information Server

The SIMATIC Information Server is an open, web-based reporting system for interactive reports. The SIMATIC Information Server has access to archived process values, messages and batch data in the Process Historian. The SIMATIC Information Server enables you to create and view reports in Internet Explorer, Excel, Word, PowerPoint as PDFs.

You can find additional information on the Information Server in the manual "Information Server Documentation (<https://support.industry.siemens.com/cs/ww/en/view/109475337>)".

### Central services of the Process Historian

Process Historian employs four services for processing, storing and backing up data:

Service	Description
SIMATIC Process Historian Server	Installs all the functions the server needs to process and store data.
Process Historian Maintenance Service	Installs all functions that are required to maintain the Process Historian database. The Maintenance Service handles tasks such as starting mirroring, mirror monitoring, restore functions, maintenance of the transaction log and suchlike.
Process Historian Redundancy Service	Installs the functions that are required for data communication between two redundant server systems.
Process Historian Discovery Service	Supports the search for connected Process Historian systems. The Discovery Service is essential for the functionality of the Process Historian.

### Encryption in Process Historian , regardless of the use of OPC UA

The encryption of data packets is essential for protecting against attacks from the net. In the standard configuration of Process Historian, encrypted communication is enabled. Process Historian API supports the encryption of communication channels.

Certificates are used to mutually authenticate communication partners. The certificates are stored in the certificate memory of the Process Historian system, in the "opc\UAClient\PKI\OPCUA" folder.

#### Enable encryption

On client PCs, you have to change the name of the Xml element from "CertificateDisabled" to "Certificate" in the following configuration files of Process Historian:

- "{ClientAppPath}\StoreAndForward2ClientConfiguration.xml"
- "StoreAndForward2ServiceConfiguration.xml"

## 3.1.2 System configurations

### Introduction

SIMATIC Process Historian and SIMATIC Information Server can be used in different system configurations.

The following shows the various system configurations that are possible:

- WinCC single-user system with Information Server
- Process Historian and Information Server together on one server
- Redundant Process Historian with Information Server as Witness
- Redundant Process Historian with Information Server and separate Witness
- Example of a PCS 7 plant

### WinCC single-user system with Information Server

With a WinCC single-user system with Information Server, the reports are generated from the short-term archive of the single-user system. Because separate long-term archiving is not planned, you do not have to use a Process Historian.

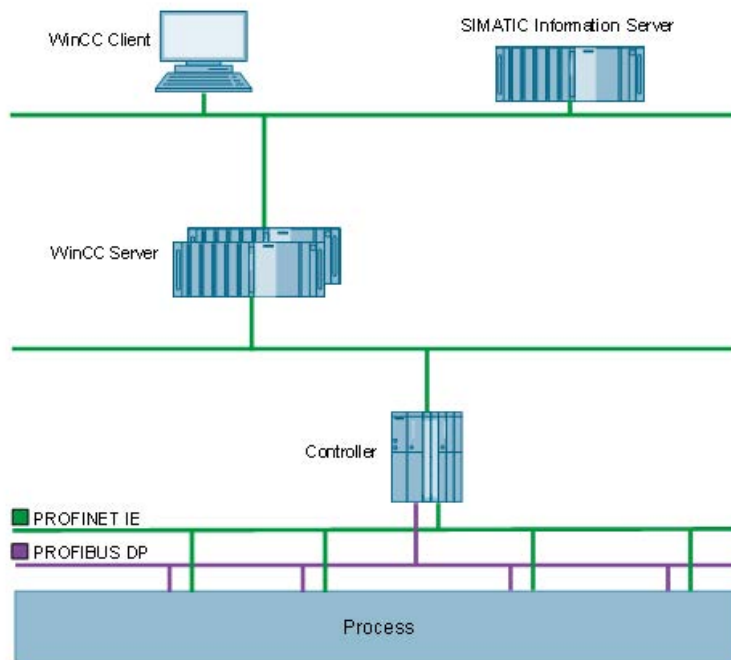

### Process Historian and Information Server on one server

Process Historian and Information Server can be installed and operated on the same server.

In this case the two server applications share the available hardware resources. Depending on the frequency of data queries from the WinCC client systems and Information Server clients, we recommend using higher-grade equipment. You need at least 16 GB of RAM.

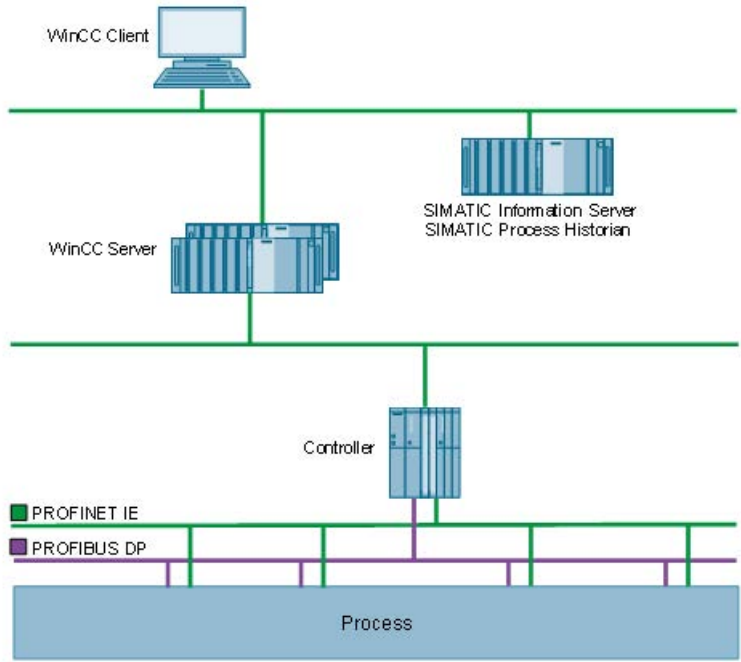

### Redundant Process Historian with Information Server as Witness

The redundant systems are based on Microsoft SQL Server Mirroring. The Process Historian needs the Witness as third system to check the availability of the redundancy. You can assign the Information Server the role of the "Witness".

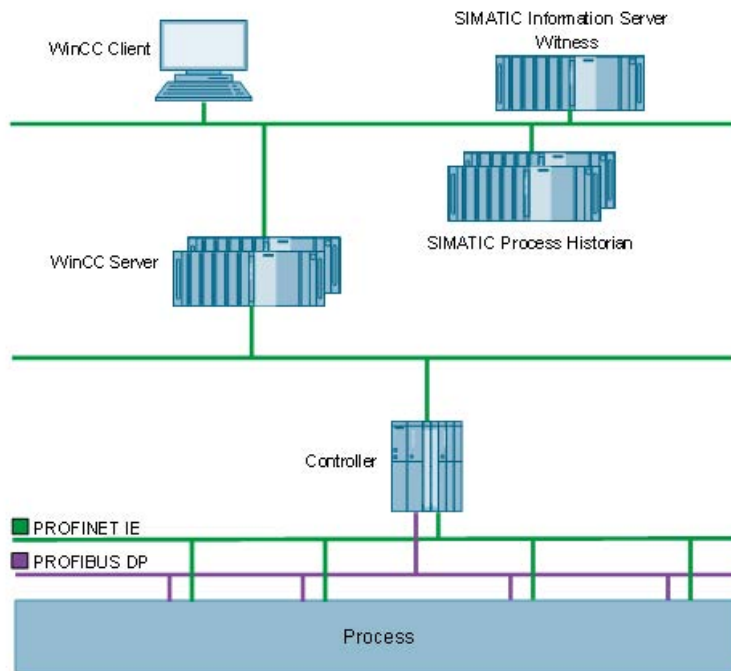

### Redundant Process Historian with Information Server and separate Witness

The redundant systems are based on Microsoft SQL Server Mirroring. The Process Historian needs the Witness as third system to check the availability of the redundancy. You can assign the role of the "Witness" to a separate server.

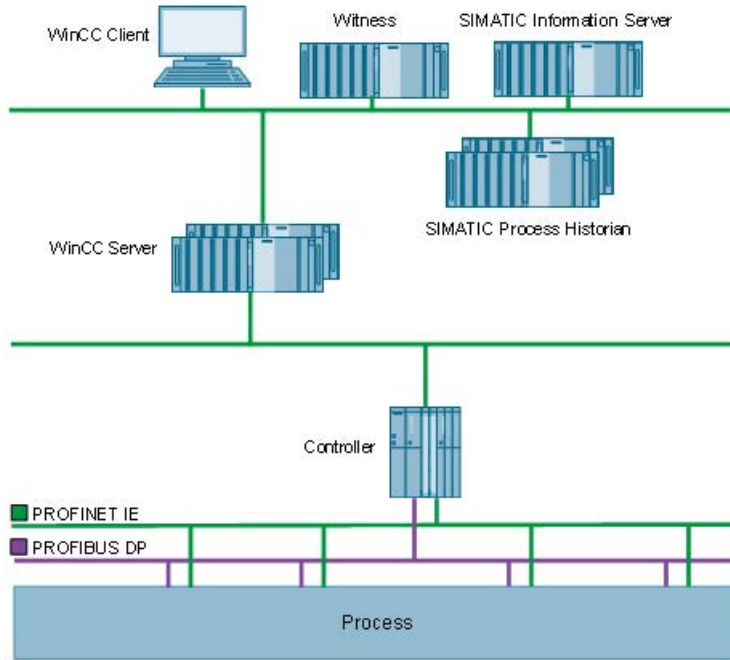

### Example of a PCS 7 plant

Process Historian and Information Server are on one server. Information Server clients receive the reports from the Information Server. over the Internet and the LAN.

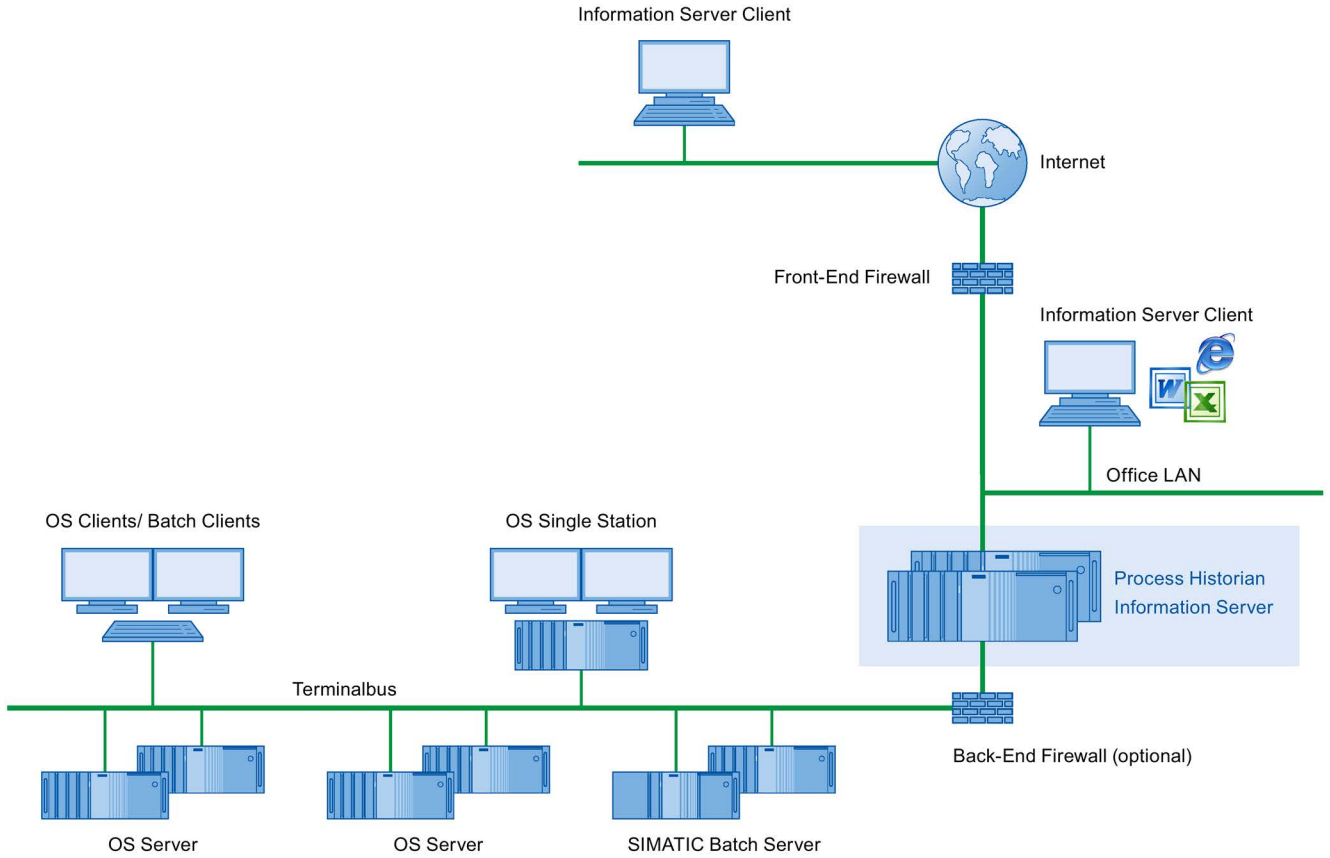

### 3.1.3 Storage structure

#### Value sequences

The Process Historian stores each value sequence to be archived, for example archive tags, and their individual values at certain points in time with a unique identifier. The physical location of the individual values is determined with this identifier.

To improve performance when archiving a large number of process values and alarms, the value sequences in the Process Historian can be divided into data groups. For example, 1000 values per data group each are organized for two data groups and 2000 values per second. The number of data groups used also depends on the number of processor cores. The maximum value of the data groups is equal to the number of cores/2.

Each data group is assigned a storage location on a shared cluster of physical sources.

- Data group 1 on drive partition 1
- Data group 2 on drive partition 2
- etc.

---

#### Note

You can distribute the data groups among the available hard disks in order to influence the performance and the scaling of the system used. You use the Database Installation Wizard to perform the distribution.

---

#### Partition

The amount of runtime data of a single value sequence to be archived is not limited and constantly increases.

The entire amount of data that is assigned to an individual value sequence must therefore be divided into several "partitions" using the time axis.

Data groups are divided into partitions using the time axis.

The following conditions apply to partitions:

- Each partition has a high and low limit for the time range.
- The high time limit is always higher than the low time limit.
- The partitions of a data group do not overlap.



### Segment of a runtime database

A segment is a summary of all archive data incurred during a period of time.

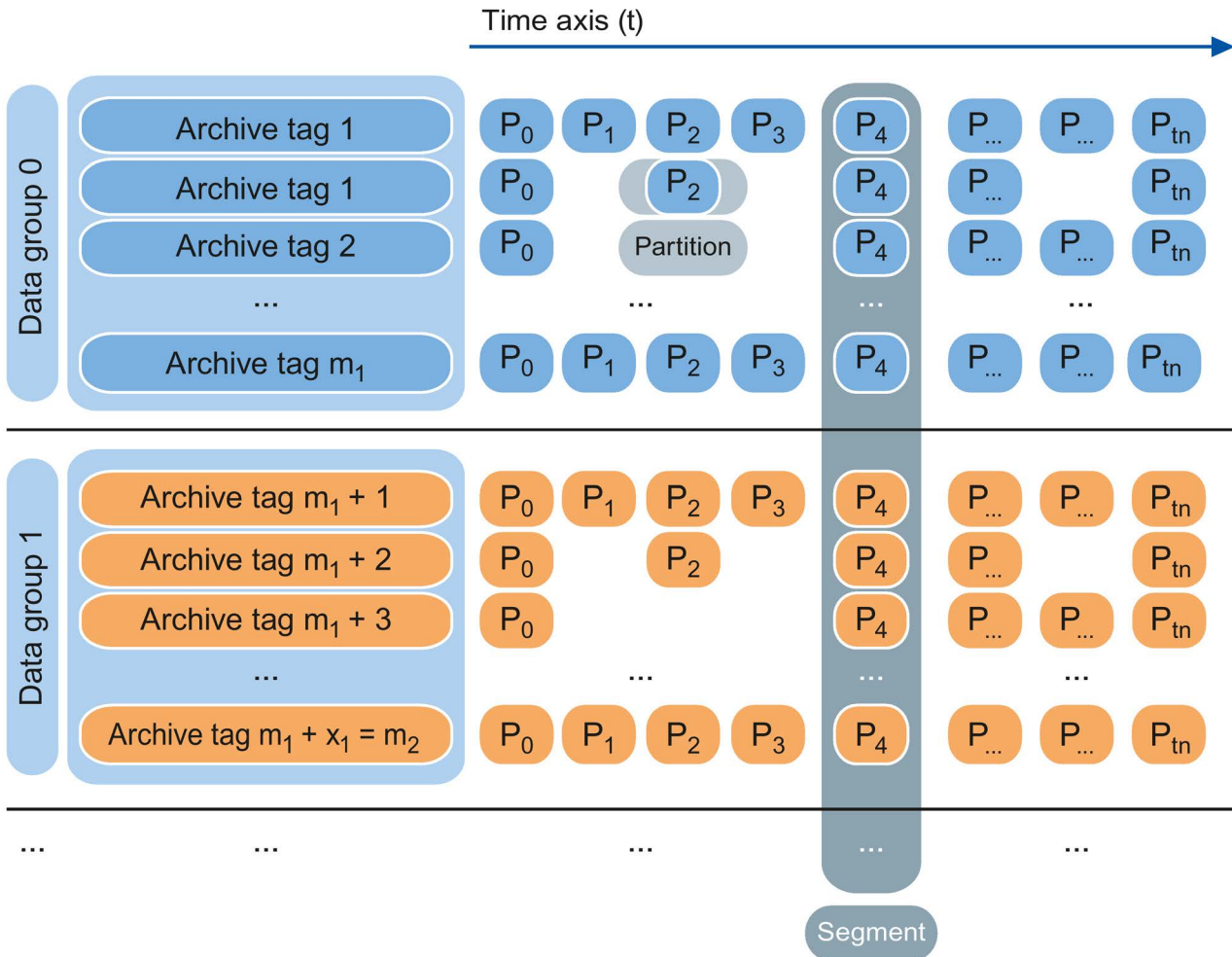

A database segment consists of the sum of partitions of all data groups that share the same high and low time limits. These groups correspond to the limits of the segment.

The difference between the high and low time limit is referred to as "time range" of the database segment.

Each segment has a unique segment number.

- The start segment, the first segment created in a system, has the number 100,000.
- The segment whose low limit is equal to the high limit of segment n is referred to as segment "n+1".
- The segment whose high limit is equal to the low limit of segment n is referred to as segment "n-1".

### 3.1.4 Segmentation - Basics

#### Introduction

In Process Historian , the following data is saved in segments with a defined time range:

- Process data specified as long-term relevant
- Messages
- Aggregation data

For example, if you choose weekly segmentation, a database segment will contain all the data recorded in one week.

We distinguish between two types of segments regarding access to data in the Process Historian :

- Online segments: The data of the segments can be displayed in WinCC Runtime through the controls and in the Information Server. They include:
  - Runtime segments
  - Archive segments
- Offline segments: The swapped out segments must be restored for the data to be displayed in Runtime and in the Information Server.

The time period for which the Process Historian has access to the data of the online segments must be based on the available absolute hard disk memory. A reserve in the size of multiple segment units must be taken into consideration, because the system temporarily needs free memory for internal processes such as segmentation, compression, etc. You must also reserve free memory to restore older backups for temporary integration of the segments in the Process Historian.

The configuration data for the process values and messages are stored in a shared area outside the segments. When a segment is swapped out, the configuration data is swapped out as well. After restoring the swapped out segments, offline segments also contain the configuration data.

## Overview of the segment types

The diagram below illustrates the relationship between the segment types in the Process Historian.

The Process Historian continuously creates runtime segments with the defined time range. When the configured number of runtime segments has been reached, the oldest runtime segment becomes an archive segment.

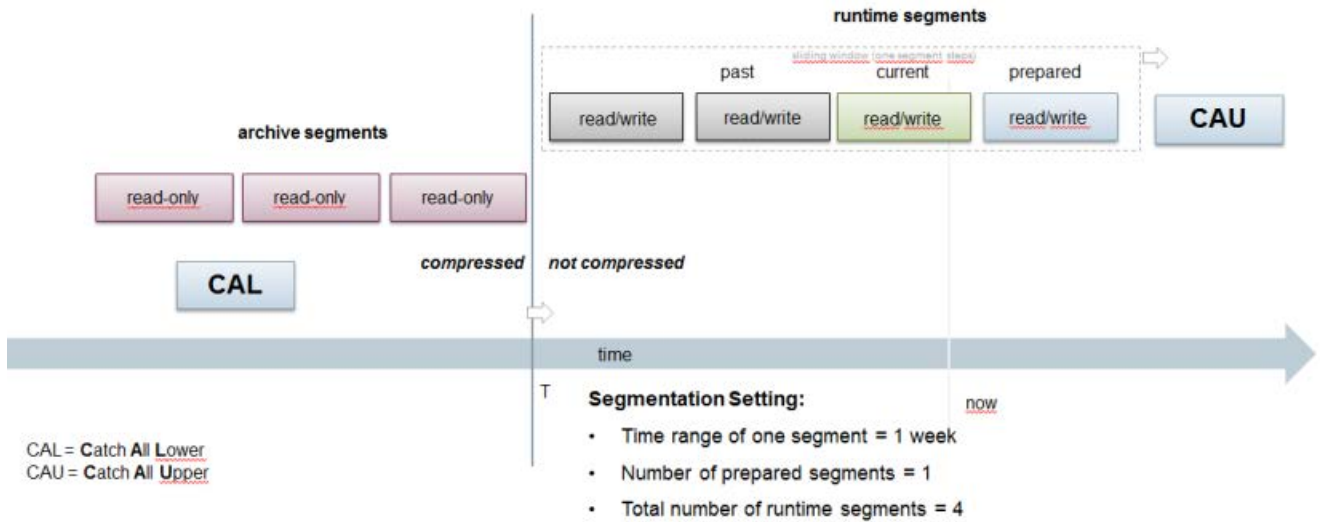

## Runtime segments

Runtime segments are segments that are in the "Online" state and to which the Process Historian can write data. A runtime segment takes the data with a time stamp that fall within the time range of the segment.

Runtime segments are uncompressed and therefore take up more space on the hard disk.

The runtime segments include the following segments that are color-coded in the "Segmentation" dashboard (Page 102) of the Process Historian:

- A segment in green receives the data with the current time stamp. The segment contains the time range of the current system time.
- Future segments in blue that are already reserved for future data. Future segments represent a safety buffer so that archiving can continue immediately in the case of a segment change. Future segments also ensure additional time for any adjustments that may become necessary when the data storage medium is very full.
- Segments in gray for process data with an older time stamp. These segments are used, for example, to transfer the data from the cache of the computer after a connection failure between a computer and the Process Historian.

The different colors of runtime segments serve to indicate whether the segmentation in the Process Historian system is still working reliably. If no green or blue segment is visible, there are general problems with the segmentation or not enough free disk space is available.

Each segment has a sequential number, starting at "100' 000". Future segments have the highest numbers.

---

### Note

A weekly segment requires less hard disk space than a monthly segment, for example. The manual backup and restore of the week segments is more complex than the month segment for the same period.

---

## Archive segments

It is not possible to write to archive segments. Only archive segments can be saved, swapped out and therefore set "Offline".

An archive segment can have the following states:

- Online: Process Historian has read access to data
- Offline: The data was successfully swapped out to a backup file and removed from the Process Historian database. The Process Historian can only access the data again when the database segment has been restored and is in the "Online" state.

Archive segments	Description
Non-compressed archive segment	During segmentation, the oldest runtime segment becomes an archive segment. Compression starts at this point, if it is enabled. Visible in the "Backup/Restore" dashboard (Page 105), top list "Status" column = "Online", "Compressed" column = "No".
Compressed archive segment	When compression is completed for a non-compressed archive segment, this archive becomes a compressed archive segment. Visible in the "Backup/Restore" dashboard, top list in the "Status" = "Online" column and "Compressed" = "Yes" column.
Past archive segments	These segments are created by the migration of the process data with the time range prior to the commissioning of the Process Historian. The segments have a sequential number lower than "100'000" and normally include a time period of one month. The Migrator itself can write all archive segments. Visible in the "Backup/Restore" dashboard, top list "Status" column = "Online", "Compressed" column = "No".
Saved archive segment	Created after backup of an archive segment in a backup file. The date of the backup is shown in the "Backup/Restore" dashboard, top list in the "Backup created" column.
Offline (swapped out) archive segment	Created after a saved archive segment is set to offline. The data of this segment is only available in the backup file. There is no data from this segment in the Process Historian database. Only the information about a backup and the offline setting is available. All segments displayed in the bottom list in the "Backup/Restore" dashboard are included in these segments.
External archive segment	Created by restoring or setting to online a backup file with an "Offline" archive segment. The data is not stored in the Process Historian database, but in an external database. Visible in the "Backup/Restore" dashboard, top list "Status" column = "External".

### Repository segments

The Process Historian creates segments continuously for a defined time range. To ensure that all data can be saved regardless of the time stamp, the Database Installation Wizard creates an upper and a lower "catch-all" segment. These segments collect all incoming data that lies outside the current runtime segments. This includes data for all types of archive segments, because it is no longer possible to write to these segments.

These segments are called "Catch-all upper" (CAU) and "Catch-all lower" (CAL) and are permanently available. You cannot swap out the segments directly to a backup file and remove them from the database.

Subtype	Description
CAL segment	<p>Contains all data from time ranges older than the oldest runtime segment. For example, a computer has not transferred data to the Process Historian for a long time. The transfer is repeated, and the data is now transferred with a date that is outside the runtime segments.</p> <p>The data from the CAL segment are continuously transferred from the Process Historian to the relevant segments if the archive segment has the "Online" status. A time range of 4 hours is transmitted approximately every 10 minutes from the CAL segment to the corresponding archive segment.</p> <p>If values are stored in the CAL segment for an "Offline" segment, this is indicated in the "Backup/Restore" dashboard (Page 105) in the lower list in the column "New data" = "Yes".</p> <p>You need to restore this "Offline" in order to enable automatic transfer of data from the CAL segment. When you perform the backup again, data from the CAL segment is entered in the backup file of the archive segment.</p>
CAU segment	<p>Contains all data from time ranges more recent than the most recent runtime segment. For the segmentation, the data with the same time range is transferred from the CAU segment into the latest runtime segment.</p>

## Configuration of the segments

Segments are configured when you set up the Process Historian database. The default is five runtime segments with one future segment and a segment has the span of one week. You can change the default setting when you set up the database.

As Process Historian administrator, you can also change the properties of the segmentation later on the "Segmentation" dashboard (Page 102). The configuration of segments that already created cannot be changed later.

The selection of the segment time range has an effect on the required hard disk space. The required disk space is calculated according to the user-defined settings of the segments and based on the estimated load of the data values.

The required space is displayed when the estimated data values are determined in the Database Setup Wizard. The space requirements needed for process values and messages to be archived are shown in the tables on the "Space requirements" (Page 74) page.

The following table provides an overview of the settings for the segmentation:

Parameter	Value	Description
Segmentation anchor point	Date, time	Start time of the segment
Segment time range	Day, week, month	Segment size. The default setting is 1 week
Factor	Integer	Multiplier for the configured period of segment. For example, the factor is "2" and the period is "Week", the segment size includes two weeks.
Number of segments	Future segments	Total number of future segments The default is 1 future segment.
	Total number of runtime segments	Number of active segments in runtime that are available for storing process values and alarms. These segments are not archived. The total number includes the number of future segments. The default is 5 runtime segments.

## Minimize space requirements for the Process Historian database

To minimize the space requirements for the Process Historian database, you can make the following settings:

- Keep the number of future segments to the default, minimum value of 1 segment. Because the anticipated required hard disk space is reserved for the future segment when it is created. The projection of the initial size is based on the last segments that were completely written.
- Set the total number of runtime segments involving week segments to the minimum value of 4 segments. This ensures that the segments are compressed at the earliest time possible.
- The number of archive segments that are reserved as non-compressed must be set to the value "0". This means compression of the archive segments can start immediately once a segment has been marked as archive segment.

### Changing the configuration of the segments

One scenario would be if you want to change the number of runtime segments because the time period for archiving in the segments has changed.

When you change the anchor point, it should refer to a time at or after the last time stamp of all segments.

If you want to change the total number of runtime segments or the number of future segments, you do not need to change the anchor point. Any existing segments are not deleted when the settings are changed, for example, when prepared segments are reduced.

This means that the new settings are not used when you reduce the future segments until the surplus and prepared segments are used. When you reduce the number of future segments from "3" to "1", for example, this setting will not become effective until two of these future segments have been written to regularly, which means after 2 weeks for week segments.

If you increase the number of future segments, segmentation with the new settings is initiated immediately. It is possible to temporarily set up one segment more than configured as future segment.

---

#### Note

If the last segment of the existing segmentation configuration ends before the anchor point of the new segmentation, an intermediate segment must be created. This intermediate segment starts with the end time of the last segment of the existing configuration and ends with the start time of the new configuration. A suitable anchor point is suggested to avoid the need for an intermediate segment. If you reject this suggestion, an intermediate segment is created automatically.

---

### Properties of the segments

The properties of segments are structured as follows:

Type	Status	Reading	Writing	Archiving	Deleting
Runtime	Online	Yes	Yes	No	No
Archive	Online	Yes	Indirect <sup>1)</sup>	Yes	No
Archive (archived)	Online	Yes	Indirect <sup>1)</sup>	Yes	Yes <sup>2)</sup>
Archive (deleted)	Offline	No	Indirect <sup>1)</sup>	No	No

<sup>1)</sup> Pending changes in the CAL segment are transferred to the archive segment during the backup.

<sup>2)</sup> Can only be deleted if no changes to the data were carried out after the last archiving.



### **Example for sequence of segmentation**

You have configured the following segmentation:

- 3 future segments
- 8 runtime segments in total
- The time range for a segment is 1 week.

Automatic backup scheduling is enabled in the "Backup/Restore" dashboard (Page 105). The number of delayed segments for setting offline has been set to "2". This means the data is always saved uncompressed for a time period of 7 (= 8 – 3 + 2) weeks in the Process Historian database.

### **Process Historian actions**

Segmentation is performed at the end of each week:

- A new future runtime segment is created.
- If there are more than 8 runtime segments, the oldest runtime segment becomes an archive segment.

Furthermore, there is a cyclical check regarding the backup to determine:

- Whether an archive segment can be backed up.
- The oldest backed up archive segment is set offline when the number of backed up archive segments is greater than the configured number of delayed segments.

### 3.1.5 Memory requirement

#### Space requirements of the Process Historian Server

When you set up the Process Historian, you must specify the anticipated space requirements for an individual segment.

The database installation wizard displays the estimated space requirements for the estimated number of process values and messages during the configuration.

---

**Note**

The more measured values or messages are archived per second, the smaller the segments should be. This prevents the individual segments from getting too large. 50,000 tags per second is the high limit that should not be exceeded.

---

#### Average space requirements

The table below shows the average space requirements of the measured variables:

Measured variable	Space requirements	Description
Process value	63 bytes	Average memory requirement per archive tag datum. The following information is saved: <ul style="list-style-type: none"><li>• Time stamp</li><li>• Process value</li><li>• Quality code</li></ul>
Message	~ 4096 bytes	Average space requirements per message. The memory requirement of a message depends to a large extent on the language used and the length of the message.

### Space requirements for process values per second

The total memory requirement for process values is calculated as follows:

(Number of future segments + 2) x segment size from the following table x 2 data groups

Process values/ s	Time range of the segment unit	Segment size (uncompressed)
500	Daily	~ 2.75 GB
3,000	Daily	~ 16.5 GB
10,000	Daily	~ 55 GB
20,000	Daily	~ 110 GB
50,000	Daily	~ 275 GB
100,000	Daily	~ 550 GB
100	Weekly	~ 3.85 GB
250	Weekly	~ 10 GB
500	Weekly	~ 20 GB
3,000	Weekly	~ 120 GB
10,000	Weekly	~ 390 GB
100	Monthly	~ 16.5 GB
250	Monthly	~ 42 GB
500	Monthly	~ 84 GB

### Space requirements for messages per second

The total memory requirement for messages is calculated as follows:

(Number of future segments + 2<sup>n</sup>) x segment size from the following table x 2 data groups

\*)CAL segment and CAU segment.

Messages/ s	Time range of the segment unit	Segment size (uncompressed)
10	Daily	~ 4 GB
50	Daily	~ 16GB
100	Daily	~ 32 GB
10	Weekly	~ 24 GB
50	Weekly	~ 116 GB
100	Weekly	~ 232 GB
10	Monthly	~ 100 GB
50	Monthly	~ 496 GB
100	Monthly	~ 992 GB

### 3.1.6 Aggregation - Basics

#### Introduction

A large volume of raw data is generated during operation. Due to the very large volume of raw data, processing a query from raw data can take a very long time.

To speed up processing of queries, aggregates are used. The aggregates link and process the incoming raw data.

The aggregates are available in the database in addition to the raw data and can be accessed through WinCC or the Information Server. The additional computing time required to process the aggregates is lower than that for processing queries based on raw data.

Approximately 3% to 6% additional space is required in the database to save the aggregates. The average space required per aggregate is approximately 128 bytes.

All aggregation values are stored in the first data group for the process values. The first data group therefore requires more disk space.

You can find additional information on aggregation in the appendix under Aggregation functionality (Page 178) and Calculating the aggregate (Page 181).

#### Aggregate types

You can use the following aggregates for a time interval:

MIN	Minimum value
MAX	Maximum value
SUM	Sum value
NUM	Number of values
INT	Integral
AVG	Average value
WAV	Weighted average value

#### Time intervals of the aggregates

The aggregates are calculated for the following time periods:

- 1 minute
- 1 hour
- 1 day

## **Example**

For a query, you want to calculate the "MAX" value over a period of one month.

### **Without aggregation**

With a raw data cycle of 1 second, the query is calculated from the following volume of raw data:

$60 \text{ (sec)} \times 60 \text{ (min)} \times 24 \text{ (h)} \times 30 \text{ (d)} = 2,592,000 \text{ values}$

The query is calculated from 2,592,000 raw data items.

### **With aggregation:**

MAX (30 days)

The query is calculated from 30 aggregate time intervals.

## 3.2 Setting up the database

### Introduction

After installing the Process Historian, continue by setting up the Process Historian database.

If a database has not been set up on the computer yet, the "DatabaseInstallationWizard.exe" file is started automatically when you insert the "Process Historian / Information Server" DVD. The "Database Installation Wizard" guides you through the configuration of the database. The "DatabaseInstallationWizard.exe" is also available in the Process Historian installation path under "\Siemens\ProcessHistorian\bin".

---

#### Note

##### Overwriting an existing Process Historian database

When you recreate an existing database with the same name, the existing database is overwritten.

---

### Requirements

- The system requirements are met in terms of hardware and security settings.
- The Microsoft Message Queuing services are installed.
- The Process Historian is installed.
- The connections to USB drives are disconnected.
- If you want to change the default settings, you need to first familiarize yourself with the basics of segmentation and the storage structure.

You can find the required information on the requirements in the document "Process Historian - Installation Notes".

## Creating a Process Historian database

1. Select the drives to be used for Process Historian.  
Do not use the following drives for Process Historian data:
  - System drive
  - Drives with partitions for License Keys or Images.
  - Drive with a partition that is used for the Information Server

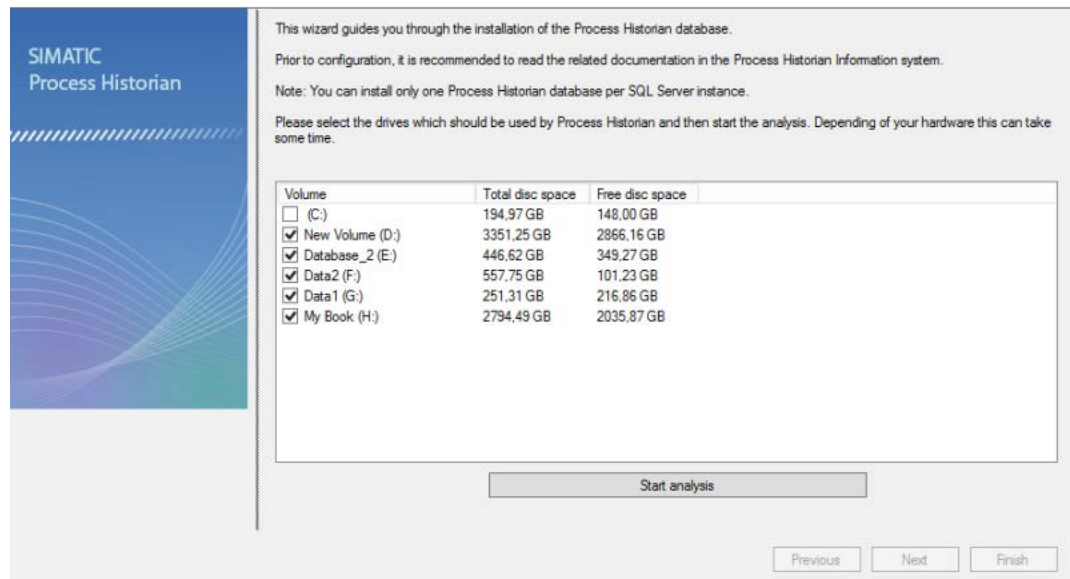

2. Click "Start analysis". The wizard analyses your system.

### Welcome

Welcome to the Process Historian Database Installation Wizard.

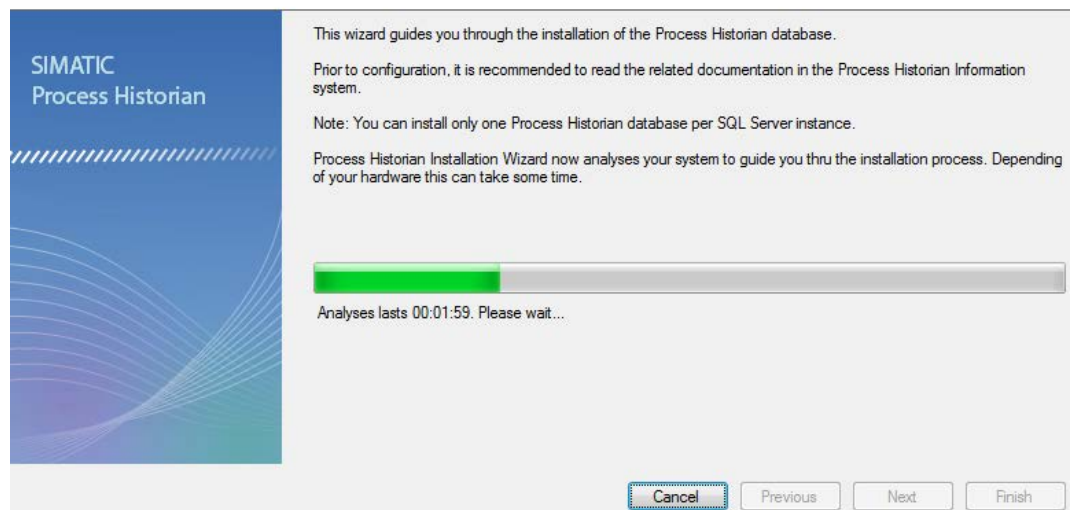

3.2 Setting up the database

3. Click "Next".
4. If the system does not find the SQL Server instance "HISTORIAN", a dialog opens in which you enter a new SQL Server instance or select an existing SQL Server instance. The wizard checks whether the Process Historian database can be installed in the selected SQL instance.
5. Click "Next".
6. Select the server mode.

**Server mode**

Select whether you want to install the master server or standby server.

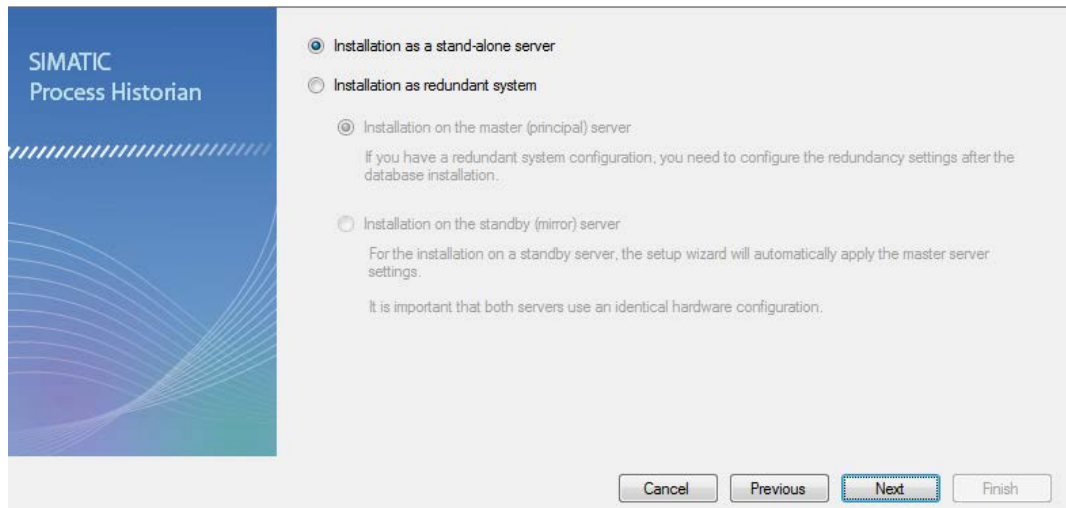

7. Click "Next". If you are using a redundant system, specify a user and password for the security setting. The Process Historian Redundancy Service is configured.

**Redundancy service configuration**

In this step you must configure the login which is used for redundant communication between the two redundant Process Historian systems

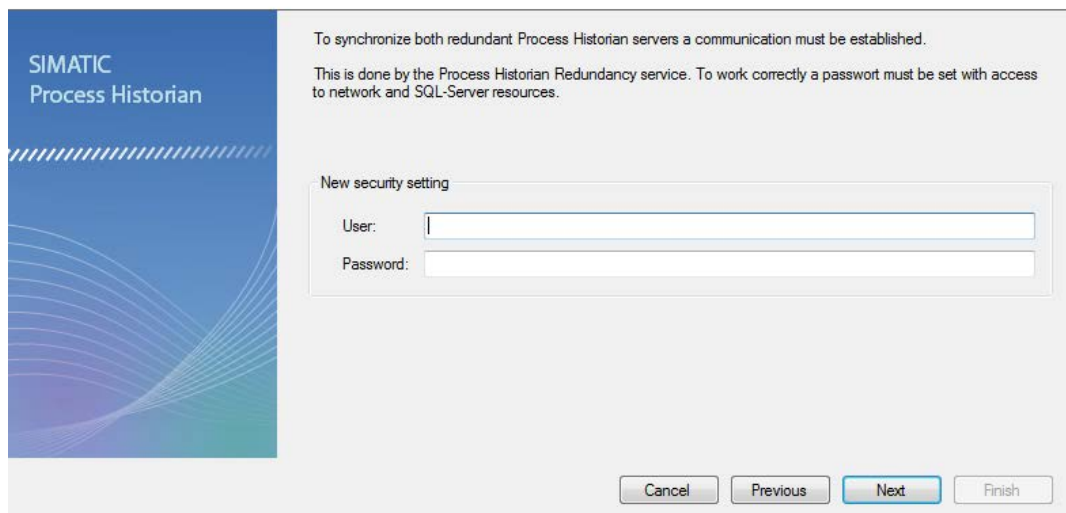



- Click "Next". An overview lists the default settings of the configured Process Historian database.

### Summary

Here is an overview of the settings you have made. Please check and start the installation process.

Topic	Action
SQL-Server instance PH1\HISTORIAN is used	
SQL-Server instance runs with 32433 MB memory on 12 cores	
This is a stand-alone machine installation	
Estimated data load is 1000 tags/s, 60 messages/m	<a href="#">Change...</a>
Default segmentation is used (Size: week, 5 runtime, 1 prepared)	<a href="#">Change...</a>
Uncompressed runtime segments can reach a estimate size of 197 GB	<a href="#">Change...</a>
All common data are located in the folder E:\Historian\DB	<a href="#">Change...</a>
Runtime message data are located in the folder E:\Historian\DB	<a href="#">Change...</a>
3 datagroups are used for storing tag runtime data	<a href="#">Change...</a>
Tag Runtime Compressed DG0 is located in the folder H:\Historian\DB	<a href="#">Change...</a>
Tag Runtime Compressed DG1 is located in the folder F:\Historian\DB	<a href="#">Change...</a>
Tag Runtime Compressed DG2 is located in the folder D:\Historian\DB	<a href="#">Change...</a>
Tag Runtime DG0 is located in the folder D:\Historian\DB	<a href="#">Change...</a>
Tag Runtime DG1 is located in the folder H:\Historian\DB	<a href="#">Change...</a>
Tag Runtime DG2 is located in the folder F:\Historian\DB	<a href="#">Change...</a>
This system is not configurated as Simatic Batch repository	<a href="#">Change...</a>
The transaction log files are located in the folder G:\Historian\TA	<a href="#">Change...</a>
Data can be stored for 47 Week	

Previous    Next    Finish

- 9. Change the default settings if necessary. Click "Change ..." at the appropriate entry
- 10. If you want to specify the expected data load of process values and messages, set the slider in the dialog below to match your estimate.

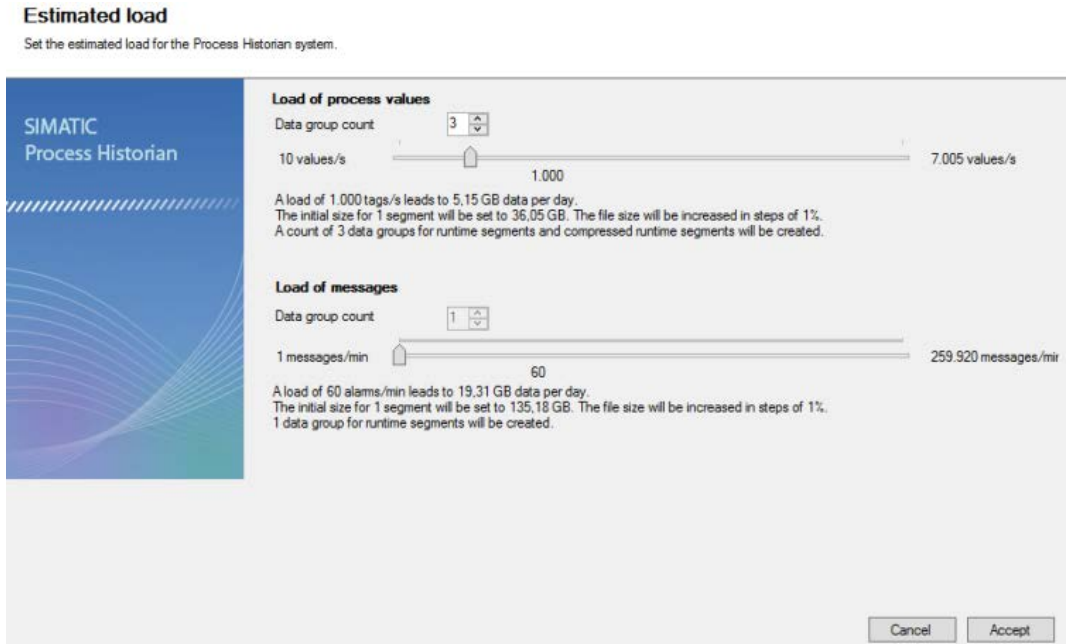

The specified quantity of process data and messages is used by the system to calculate the reserved space and thus the size of the segments. After some of the segments have been written, the system calculates the segment size from the number of values saved in the previous segments.

**Note**

When using a WinCC server in Runtime mode, you can estimate the average number of tags per second that are saved on the WinCC server by using the internal tag "@TLGRT\_AVERAGE\_TAGS\_PER\_SECOND". However, the value is only conditionally equivalent to variables relevant over the long-term.

11. If you want to define the segmentation of the database yourself, configure the segments. The default setting is five runtime segments with one future segment. One segment has the time range of one week.

### Segmentation settings

Configure the segmentation of the Process Historian archives

The screenshot displays the 'Segmentation settings' dialog box for SIMATIC Process Historian. On the left is a blue sidebar with the SIMATIC Process Historian logo. The main area is divided into three sections: 'Preview', 'Settings', and 'Buttons'.  
 - **Preview:** Shows five segments labeled S-3, S-2, S-1, S0, and S+1. Below each label is a colored bar representing its time range: S-3 (grey), S-2 (grey), S-1 (grey), S0 (green), and S+1 (blue). Below these are three labels: 'Past' (grey bar), 'Current' (green bar), and 'Prepared' (blue bar).  
 - **Settings:** Contains three groups of controls:  
 - **Segment time range:** 'Unit' is set to 'Week' and 'Factor' is '1'.  
 - **Segmentation anchor point:** 'Hour' is '0' and 'Date' is '09.11.2015'.  
 - **Number of segments:** 'Number of prepared segments' is '1' and 'Total no. of runtime segments' is '5'.  
 - **Buttons:** 'Cancel' and 'Accept' buttons are at the bottom right.

12. If you want to change the drive for data files and log files, you can set the path for the files. Only local destination paths are permitted.

### Note

#### Distribute data files on different hard disks

Selecting different drives for the database files improves the performance of the storage system. Different partitions on one hard disk do not provide any improvement in performance.

For Process Historian systems with medium and large configuration limits, the tag and alarm load must be distributed across various hard disks. The hard disk access time is too high for all the data to be written to one hard disk. From about 3000 tags/s, you should distribute the data across different hard disks.

#### Do not use certain drives for Process Historian

Do not use the following drives for Process Historian data:

- System drive
- Drives with partitions for License Keys or Images.
- Drive with a partition that is used for the Information Server

### 3.2 Setting up the database

13. If you want to specify the Process Historian server as SIMATIC BATCH repository, select the check box and enter the path for the data files.

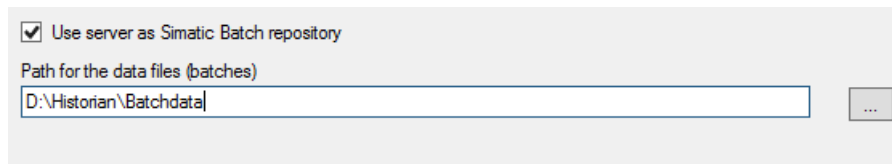

The screenshot shows a configuration dialog box with a checked checkbox labeled "Use server as Simatic Batch repository". Below it is a text field labeled "Path for the data files (patches)" containing the text "D:\Historian\Batchdata". To the right of the text field is a button with three dots "...".

14. Check the overview. If all information is correct, click "Finish".

The database is now created. The progress of the database installation is documented in a window.

A message is displayed when the installation is completed successfully.

15. Shut down the wizard with "Close".
16. Restart the computer so that all services can be installed.

## Result

You have successfully set up a Process Historian database.

## 3.3 Data transfer from PH-Ready to the Process Historian

### Introduction

The process values and messages relevant over the long-term on an OS server are transferred via the PH-Ready to the Process Historian database. The chronological order of data transfer must be observed.

All servers and all S7 controllers that assign time stamps for process values and messages must be time-synchronized. The data archived with ODK by WinCC must be written synchronously.

### Transmission sequence

1. PH-Ready first stores all process values and messages "Store and Forward Cache" relevant over the long-term on a local drive. The "Store and Forward Cache" is created on the computer in the installation folder with the path "C:\Program Data\Siemens\SFCache". Data are prepared in the "Store and Forward Cache" to enable them to be optimally transferred to the Process Historian .
2. PH-Ready transfers the data from "Store and Forward Cache" to the Process Historian.
3. The Process Historian stores this data in the Process Historian database.
4. The Process Historian acknowledges the successful storage of the data to PH-Ready. While PH-Ready is waiting for the acknowledgment of the transmitted data, PH-Ready stores the next data from WinCC in the "Store and Forward Cache".
5. PH-Ready releases the allocated "Store and Forward Cache" once again.

The normal flow of the transmission ensures that the data is transferred to the Process Historian in a timely manner to where and then stored there in the current runtime segment.

### PH-Ready and Process Historian are separate

1. PH-Ready continues to store data in its local "Store and Forward Cache".
2. The "Store and Forward Cache" will grow until free disk space reaches a low limit.

**The connection to the Process Historian is restored**

1. PH-Ready transfers the data from "Store and Forward Cache" to the Process Historian.
2. When space is free again on the drive, the data missing in the "Store and Forward Cache" is read directly from the WinCC archive and transferred to the "Store and Forward Cache".

Reading large amounts of data from the WinCC archive reduces the performance compared to direct acquisition in the "Store and Forward Cache".

The data sent to the Process Historian are stored there in the CAL segment, if the data is older than the oldest runtime segment of the Process Historian. The data of CAL segment are sent in an automatic process to the Process Historian in the appropriate archive segments. You therefore need to restore it archive segments already set offline. You can see whether you need to restore a segment in the "New data" column of the "Backup/Restore" dashboard. You need to repeat the backup of an archive segment that has received additional data from the CAL segment.

To be prepared for the delayed transfer of the data, select the number of correspondingly large runtime segments and slow down the backup of the archive segments and setting them offline.

**NOTICE****Behavior with reduced memory**

The available memory is monitored with PH-Ready .

The "Store and Forward Cache" can grow in the following cases:

- Loss of connection to the Process Historian server
- Reduced performance when processing the transmitted data on the Process Historian server, because the transfer involves numerous additional accesses to read data from the WinCC archive.

The allocated "Store and Forward Cache" is released again when the cached data has been transmitted to the Process Historian server.

**Alarm to WinCC**

An alarm is sent to WinCC when one of the following situations occurs:

- The free space for the "Store and Forward Cache" drops below the limit of 10 GB.
- The free space for the "Store and Forward Cache" amounts to less than 13% of the reserved drive capacity. The value can drop to 6% for hard drives with less than 60GB total capacity.

**Interruption of data transmission**

Saving to "Store and Forward Cache" and transmission of data is interrupted when one of the following situations occurs:

- The free space for the "Store and Forward Cache" drops below the limit of 5 GB.
- The free space for the "Store and Forward Cache" amounts to less than 10 % of the reserved drive capacity. The value can drop to 3% for hard drives with less than 60GB total capacity.

As of this time, the process data is only available in the WinCC archive.

Saving to "Store and Forward Cache" automatically resumes when the available memory is increased. You can increase the free space available by using a larger hard disk or by removing files. The free space also increases when data has been successfully transferred from the available "Store and Forward Cache" to the Process Historian, acknowledged by the Process Historian and deleted in the "Store and Forward Cache".

**Adapt the circular buffer of the WinCC archives**

Configure the circular buffer in the WinCC archive large enough so that longer connection failures between PH-Ready and WinCC are taken into account. After all, it is only possible to read the data from the WinCC archive if the data in the archive are still available.

### Configuring the data transfer to the Process Historian database

#### Requirements

- The PH-Ready is installed.
- The PH-Ready services is configured.

You can find the required information on installation and configuration of services in the document "Process Historian - Installation Notes".

#### Configuration

1. In the navigation window of WinCC Explorer, use the entry "PH-Ready" to open the "WinCC Process Historian Editor".
2. On the "Server" tab, select the Process Historian server to which PH-Ready will transfer the archive data. If you are using a redundant system, select the standby server as second computer.

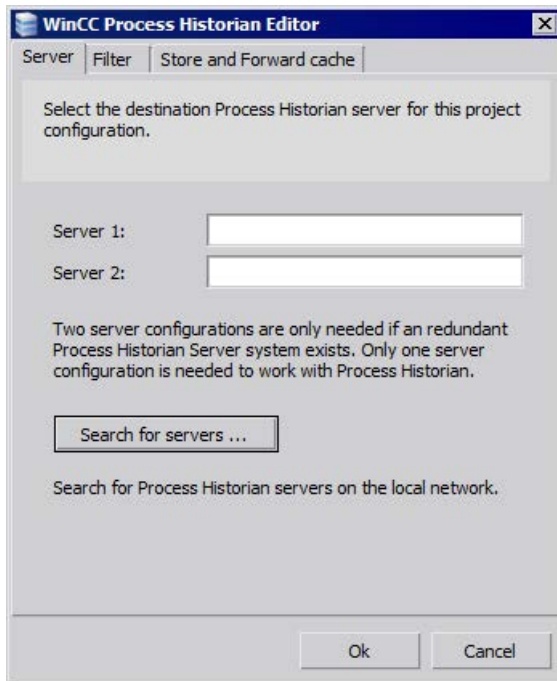



3. On the "Filter" tab, select which information is transferred to the Process Historian server.

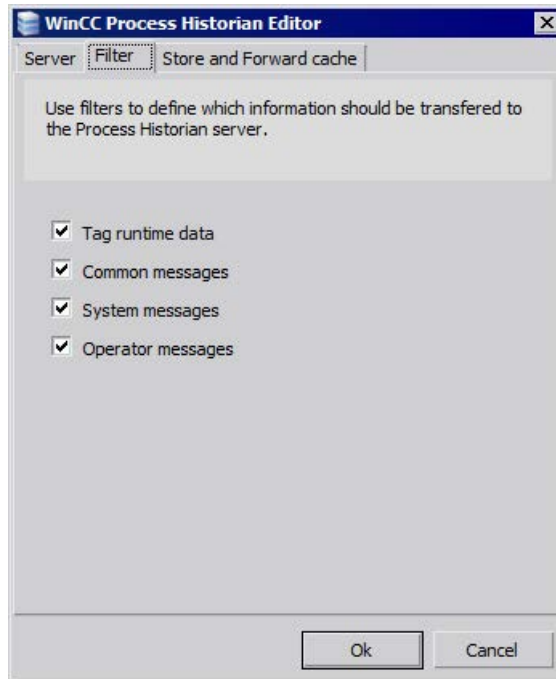

## 3.4 Commissioning

### Introduction

This section provides an overview of the commissioning of the Process Historian using a WinCC project as an example.

During initial commissioning, you must start the Process Historian before the WinCC servers. The Process Historian must also be in the "Active" operating state before you start WinCC Runtime. If you start the Process Historian after the WinCC server, the WinCC server may not be able to correctly build the required Message Queues .

### Requirements

- The Process Historian must be installed.
- The database was created with the Database Installation Wizard.
- The database segmentation has been set.
- The following licenses must be available:
  - Server license for the Process Historian
  - If the license does not exist, the Process Historian does not switch to the "Active" state after the computer starts.
- The required necessary Process Historian services are active:
  - SIMATIC Process Historian Service
  - Process Historian Maintenance Service
  - Process Historian Discovery Service
- The Process Historian is activated.
- PH Ready (CCCAPHServer Service) is installed on the WinCC server and has been started.
- The WinCC project has been loaded on the target server.

## Procedure

1. Open the management console of the Process Historian. The Management Console is started automatically at logon. You can manually open the Management Console with "Start > Programs > Siemens Automation > SIMATIC > Process Historian > Process Historian Management Console".
2. Click on the "Process Historian Management" node.
  - There is no connection to a data source and there are no tags and messages saved. Every WinCC system with data stored on it is regarded as a source. The Process Historian receives the configuration data from each configured WinCC Runtime system.
  - When a redundant WinCC system is used, the master server and the standby server are the data sources. The archive configuration data are transmitted from both servers. The runtime data is only sent from the current master server to the Process Historian.
3. Open WinCC Explorer on the WinCC server .
4. Start the loaded WinCC project. The WinCC server sends the configuration data to the Process Historian.  
In the following figure you can see that a data source, the WinCC server, is connected to the Process Historian.

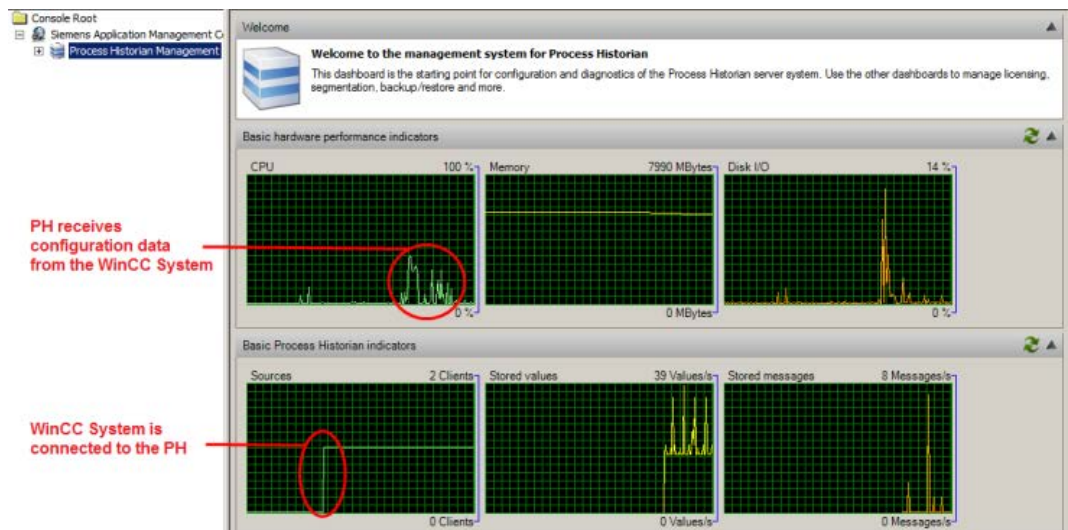

3.4 Commissioning

- 5. Start WinCC Runtime. Once Runtime is started, long-term relevant archive tags and WinCC messages are saved on the Process Historian.

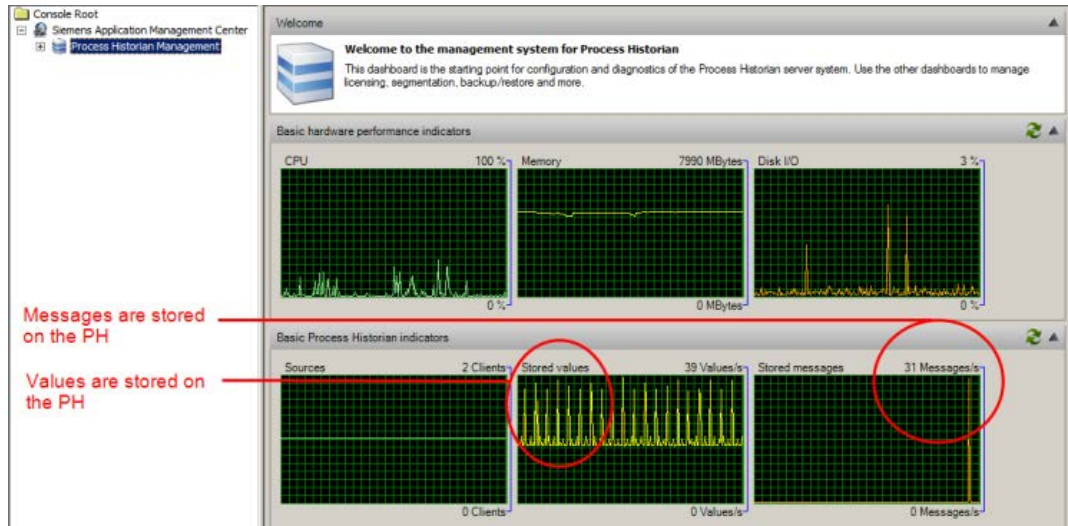

## 3.5 Recovering a database

### Introduction

This section describes the sequence for restoring a Process Historian database.

When you restore a Process Historian database, you restore the state of the database in the Process Historian that existed at the time of the last database backup.

---

#### Note

If you reinstall the Process Historian server after an operating system change, for example, and then wish to restore the database, you need to cancel the "Database Installation Wizard" directly when it starts. Afterwards, restore the database according to the described procedure.

---

### Requirement

- Restoring the database is only started when a previously started database backup is completed. You can find information on database backup in the section "Backing up the database (Page 111)".

### Restoring a Process Historian database

1. Start the "Database Recovery" program in the start window of the operating system.

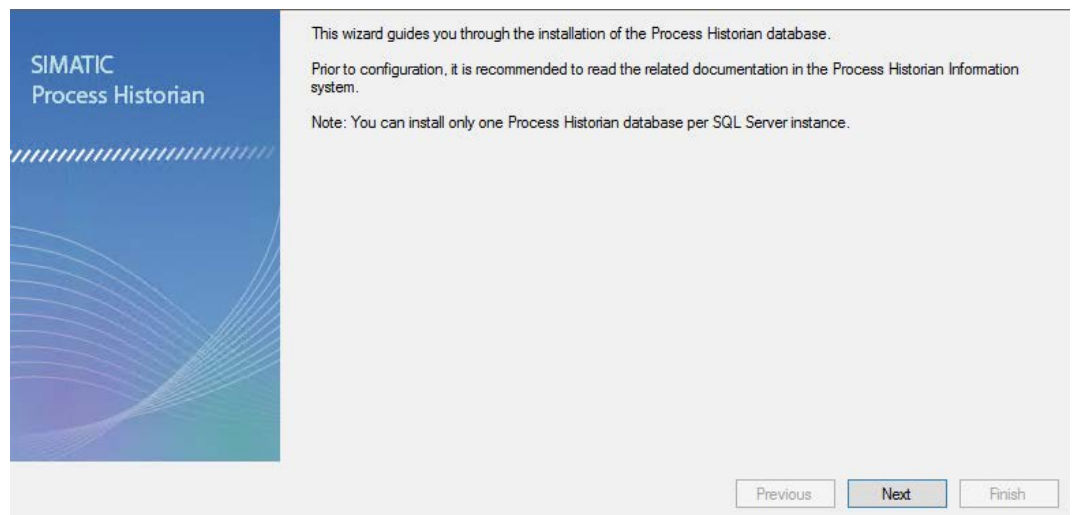

3.5 Recovering a database

2. Click "Next".
3. Enter the path of the required database backup. The database backup is checked to determine whether it can be restored.  
The name of the destination path must match the database name and destination path. If the path has been renamed, you cannot not restore and an error message is output.

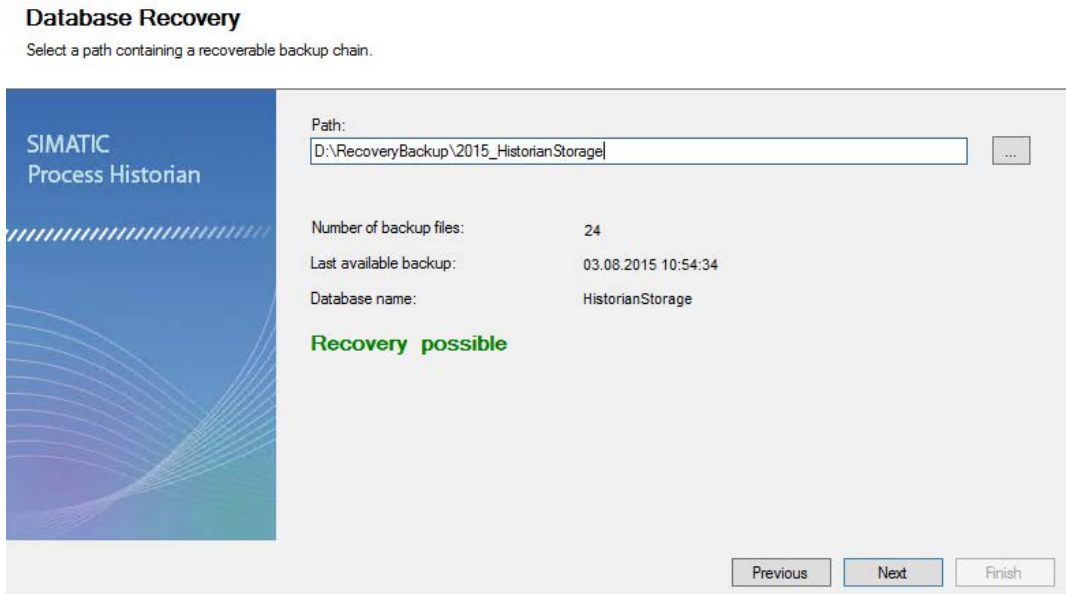

4. Click "Next".  
A recovery overview of the information is displayed before recovery is started.
5. Click "Next".  
Recovery of the database is now started. The recovery progress is displayed.  
A message is displayed when the recovery is completed successfully.
6. Exit the program with "Close".
7. Restart the computer so that all services can be installed.  
After restart, database backup is set to "Disable".

**Result**

You have successfully recovered a database.

## 3.6 Managing Process Historian

### 3.6.1 Management Console - Overview

#### Introduction

The Management Console comprises several dashboards that are available for configuration of the Process Historian and for information or diagnostics of the system. The Management Console is installed with the installation of the Process Historian and started automatically at logon. For a manual start, open the Management Console by selecting "Start > Programs > Siemens Automation > SIMATIC > Process Historian > Process Historian Management Console".

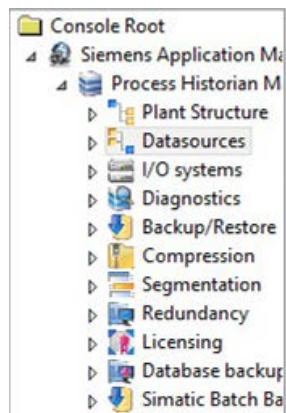

---

#### Note

##### Certificate verification by Internet Explorer

In Internet Explorer under "Internet Options > Advanced > Security", deactivate the option "Check for publisher's certificate revocation".

If this option is activated, it can slow down opening of the Process Historian and cause error messages.

---

## Dashboards - Overview

The following table shows the dashboards of the Management Console and their tasks:

Dashboard	Tasks	Documented in section
Process Historian Management	<ul style="list-style-type: none"> <li>• Display of basic information about hardware and performance, PC and operating system</li> <li>• Display of status and current activity of the Process Historian server</li> <li>• Display of the license status</li> <li>• Redundancy status</li> <li>• Changing the operating state</li> </ul>	<p>Central overview of the Process Historian Server (Page 100)</p> <p>Operating states of the Process Historian (Page 98)</p>
Plant structure	<ul style="list-style-type: none"> <li>• Display of incorporated projects</li> <li>• Display of the OS server systems</li> <li>• Display of the PC name</li> </ul>	Information on the plant structure of the projects (Page 115)
Data sources	<ul style="list-style-type: none"> <li>• Display for each individual data source of when configuration data and runtime data was last transferred to the Process Historian</li> <li>• Display of the last lifebeat</li> <li>• Deletion of the configuration data of the projects</li> <li>• Setting a lock to prevent deletion of configuration data</li> </ul>	Information on the data sources (Page 117)
I/O systems	<ul style="list-style-type: none"> <li>• Display of the available input and output devices</li> <li>• Display of the storage space used</li> <li>• Detailed information about the load</li> </ul>	Information on the storage system (Page 119)
Diagnostics	<ul style="list-style-type: none"> <li>• Diagnostic messages of the Process Historian</li> <li>• Messages from the event display of the operating system</li> </ul>	Diagnostics of the Process Historian (Page 122)
Backup/Restore	<ul style="list-style-type: none"> <li>• Display the archive segments</li> <li>• Creating segment backups</li> <li>• Restoring backed-up segments</li> <li>• Removing segments</li> </ul>	<p>Backup of segments (Page 105)</p> <p>Restoring segments (Page 109)</p> <p>Set segments "Offline" (Page 110)</p>
Compression	<ul style="list-style-type: none"> <li>• Display of the compression state</li> <li>• Configuration of the number of uncompressed archive segments</li> </ul>	Compressing segments (Page 104)
Segmentation	<ul style="list-style-type: none"> <li>• Display of the current segmentation setting</li> <li>• Changing the segmentation settings</li> </ul>	Configuring segments (Page 102)
Database backup	<ul style="list-style-type: none"> <li>• Manual creation of full database backups</li> <li>• Automatic, continuous creation of full database backups</li> </ul>	Backing up the database (Page 111)



Dashboard	Tasks	Documented in section
Redundancy	<ul style="list-style-type: none"><li>• Display of the redundancy status</li><li>• Switchover / disconnection of principal (master) and mirror (standby)</li><li>• Redundancy configuration</li></ul>	Setting up Process Historian redundancy (Page 156)
Licensing	<ul style="list-style-type: none"><li>• Display of the current license status of server and project</li></ul>	Information on the licenses (Page 121)
SIMATIC Batch Backup/Restore	<ul style="list-style-type: none"><li>• Display of the selected batch data</li><li>• Create backups of batch data</li><li>• Restoring backed-up batch data</li></ul>	Backing up and restoring batch data (Page 123)

### 3.6.2 Operating states of the Process Historian

#### Overview of operating states

The following table provides an overview of the operating states of the Process Historian database and the color code of the associated icons in the status bar:

Symbol	Process Historian operating state	Description
	Active	In the "Active" operating state, the Process Historian archives data. You can query data from the OS Server or the Information Server.
	ActiveRecovery	In the "ActiveRecovery" operating state, the Process Historian requests data from an OS Server for a recognized period without archiving the data. The preceding and the subsequent operating state is "Active".
	Starting ActiveRecovery	This operating state starts "ActiveRecovery".
	Stopping ActiveRecovery	This operating state terminates "ActiveRecovery" and is the intermediate state between "ActiveRecovery" and "Active".
	Disabled	The Process Historian changes to the "Disabled" operating state in the case of maintenance tasks where access to the database is limited. The maintenance tasks can include the creation or the backing up/restoring of segments. The system is offline in this operating state. Access via the network is not possible.
	Locked	The Process Historian server is in "Locked" operating state, for example, because the disk space has reached its capacity limit. In this operating state, the Process Historian server can no longer be switched to "Enabled". No more values are archived. Read access to stored values is possible.
	Disabling	"Disabling" is the intermediate state between "Active" and "Disabled".
	Error	The "Error" operating state occurs when an error has been detected or when there is no connection to the SIMATIC Process HistorianServer service.
	Inactive	No data are archived in the "Inactive" operating state. In this operating state, you can carry out updates, maintenance work to the Process Historian PC or a restart of the PC.
	Shut down	The intermediate state between "Active" and "Inactive".
	Starting	The intermediate state between "Inactive" and "Active".
	Paused	Mirror paused. The database is synchronized with the principal. The database of the mirror is used exclusively by the principal. Access from other applications is not possible.

### Commands

You can give the Process Historian the following commands by using the shortcut menu of the icon in the status bar:

- Start
- Shut down
- Start recovery

#### NOTICE

##### Disabling the Process Historian server before shutting down

You must disable the Process Historian server before shutting down the computer on which the Process Historian server is running. There are two options available to you:

- In the start screen of the Process Historian Management Console, select the "Shut down" status.
- In the shortcut menu of the status bar of the Process Historian, select the "Shut down" command.

The "Inactive" status is displayed.

### "Locked" operating state of the Process Historian server

If insufficient disk space is available on a monitored drive, the maintenance service sets the Process Historian server to the "Locked" operating state.

In this operating state, the Process Historian server can no longer be set to "Enabled". The maintenance service can set the Process Historian server to "Active" again only when free space has been increased.

#### NOTICE

##### Avoiding the "Locked" operating state

To ensure enough free space is available for the operation of the Process Historian, regularly check the currently available space in the "I/O systems" dashboard.

Determine which automatic mechanisms for reducing the used space can be activated in the dashboards.

Information on how to check or monitor the storage space and increase the storage space is available in the section Information on the storage system (Page 119).

### 3.6.3 Central overview of the Process Historian Server

#### Overview

The "Process Historian Management" dashboard provides you an overview of the basic information about the Process Historian. Configuration and diagnostics information of the Process Historian are displayed together here.

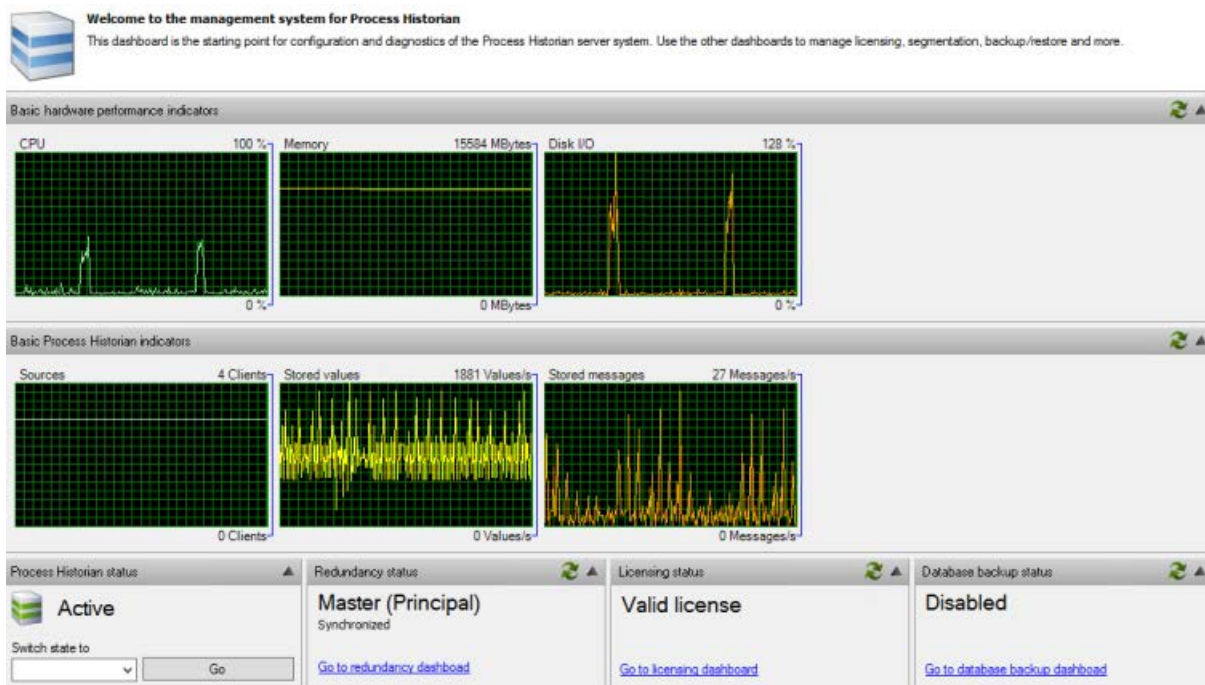

The following information is displayed on the "Process Historian Management" dashboard:

- Monitoring the PC:
  - Processor load (CPU)
  - Available RAM
  - Hard disk load (Disk I/O)
- Process Historian:
  - Number of connected data sources
  - Stored tags per second
  - Stored messages per second
- Operating state of the Process Historian server You can change the operating mode here:
  - Start
  - Shut down
  - Start recovery

- Redundancy status of the Process Historian: Here you can update the status
- Licensing status of the Process Historian: Here you can update the status
- Automatic backup Process Historian: Here you can update the status

---

**Note****Display in percent**

Percentage values displayed can exceed 100 % for a short time. These values are determined by a statistical extrapolation from mean values. They do not correspond to the real values.

---

### Display of the operating state on the operator station

The operating mode of the Process Historian system is displayed on the operator station, which can access the Process Historian via "PH-Ready". With a redundant Process Historian system, the status of the Master (Principal) and Standby (Mirror) are displayed.

The following is displayed in the area overview of operator station:

- Green button: The monitoring of the Process Historian Server is active. The server status is "OK".
- Red button: Open the detail view and check the entries in the row "Process Historian". When a Process Historian server name is red, check the operating state and the redundancy status on this dashboard in the Management Console. If red is displayed for the active servers of master and standby, the witness server has failed.

To monitor the status, the following system tags that reflect the current state of the Process Historian are created in the tag management:

- @PHServer\_Principal\_State
- @PHServer\_Principal\_Details
- @PHServer\_Mirror\_State
- @PHServer\_Mirror\_Details

Example for "@PHServer\_Principal\_State" and "@PHServer\_Mirror\_State":

- PHServer=1. Name of the Process Historian server and the current status. "1" means "OK", "0" means "error".

The variables "@PHServer\_Mirror\_State" and "@PHServer\_Mirror\_Details" are written only for mirrored systems.

The variables "@PHServer\_Principal\_Details" and "@PHServer\_Mirror\_Details" contain detailed information about when an error has occurred. You can further process these variables with WinCC. The information is contained in XML elements. You can find the form and explanation of the contents in XML elements in the appendix on the page Detailed information on the operating state (Page 188)

If you cannot make a connection from the PH-Ready to the Process Historian server, the "Error" state is shown. No information pertaining to the Process Historian is provided thereby.

### 3.6.4 Configuring segments

#### Introduction

The "Segmentation" dashboard provides an overview of the current configuration of the segmentation.

When the Process Historian is set up, the default is five runtime segments with one future segment and a segment has the span of one week.

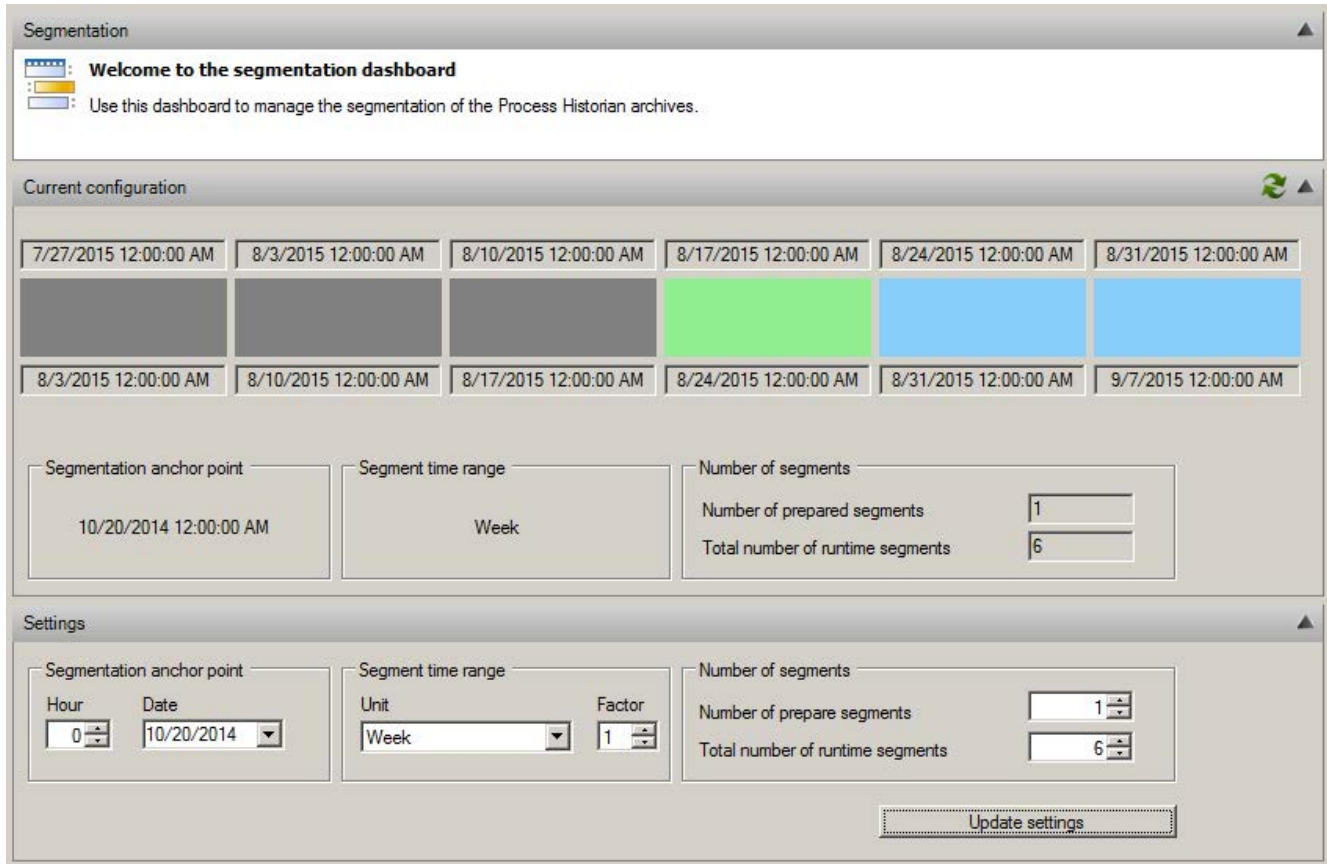

The runtime segments include the following segments that are color-coded:

- A segment in green receives the data with the current time stamp.
- Future segments in blue that are already reserved for future data.
- Segments in gray for process data with an older time stamp.

## Configuration of the segmentation

You configure the segmentation of the Process Historian archives in the "Settings" area.

1. Segmentation anchor point:

- Hour
- Date

2. Time period for segments:

- Unit (period)
- Factor

3. Number of segments:

- Number of future segments
- Total number of runtime segments

Depending on the configuration limit, the amount of data on the hard disk per segment can be very large. This is especially true for uncompressed runtime segments. When the segments are created, the estimated required storage space is calculated taking into account the size of the previous segments and reserved for future segments.

The segments for historical data generated by the migration is initially created with minimal size. When data is imported, the segments are automatically enlarged by the SQL server.

The optimum settings for the segmentation are a compromise between the occupied storage space and the number of uncompressed data segments to be reserved.

---

### Note

The Process Historian database is switched automatically to the "Deactivated" operating state to allow changes to the segmentation to be carried out. After the settings have been applied, the database changes back to the "Active" operating state automatically.

---

## Result

The segmentation of the Process Historian database is configured.

The time range of the archived data that is available as read-only depends on the number of runtime segments plus the number of archive segments that are not set offline.

### 3.6.5 Compressing segments

#### Introduction

Internal compression of the archive segments includes the tables of the archive tags and reduces the space requirements of the Process Historian server. Uncompressed segments have the advantage of delivering data faster when archived data is accessed.

On the "Compression" dashboard, you can see the current compression state as well as the number of uncompressed segments. The default setting is "0" uncompressed segments. Compression then begins with the first archive segment.

The reduction in space requirements through compression depends on the saved values. For example, if a value does not change over an extended period of time, the compression factor is high. If a value changes constantly, the compression ratio is lower. A compression factor of "5" is a conservative assumption.

---

#### Note

The archive segments are compressed automatically in the background.

---

#### Procedure

1. Select the "Compression" dashboard in the navigation of the management console.

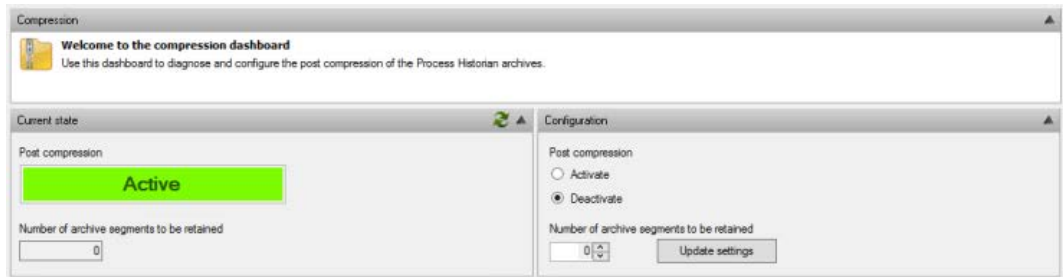

2. Select the "Activate" option in the 'Configuration' area for 'Post compression'.
3. Specify the number of uncompressed segments you want to keep in the "Configuration" area.
4. Click "Apply".
5. The "Current status" area indicates whether compression is enabled and, if so, as of which segment.

---

#### Note

The space requirements may increase when you make changes to the default setting.

---

#### Result

The settings for the compression of archive segments have been reconfigured.



## 3.6.6 Backup of segments

### Introduction

The storage space of the Process Historian is continuously filled with data. If the free space falls below a limit, the Process Historian is set to the "Locked" operating state and archiving is stopped.

To ensure that you have enough free space available again in time, you can:

- Back up the segments manually or automatically
- Set the backed-up segments "Offline" or swap them out, thereby removing them from the Process Historian

The backed-up data is initially available in the backup file as well as in the Process Historian database. The segment data is only removed from the database, thus freeing up hard disk memory on the database drives, when the segment is set "Offline" or the respective option is enabled in automatic scheduling.

You can also specify for automatic backup planning a number of delayed segments that are set "Offline" at a later time. The existing data of the delayed segments therefore remains available "Online" longer.

### Overview

All archive segments of the Process Historian are displayed in the "Backup/Restore" dashboard:

- Segments with the status "Online" can be backed up manually or automatically.
- Segments already backed up with the "Offline" status can be restored. You can find additional information on this in Restoring segments (Page 109).

The screenshot shows the 'Backup/Restore' dashboard interface. At the top, there is a 'Welcome to the backup/restore dashboard' message with a blue folder icon and the text: 'Use this dashboard to manage your backups of Process Historian data segments.' Below this is the 'Archive segments' section, which contains a table with the following data:

Segment ID	Status	Type	From	To	Unit	Flag	Compres...	Backup created
99996	Online	Archive	4/20/2015 2:00 AM	5/18/2015 2:00 AM	Week (4)	Valid	Yes	
99997	Online	Archive	5/18/2015 2:00 AM	6/15/2015 2:00 AM	Week (4)	Valid	Yes	
100000	Online	Archive	7/27/2015 12:00 AM	8/3/2015 12:00 AM	Week	Valid	Yes	
100001	Online	Archive	8/3/2015 12:00 AM	8/10/2015 12:00 AM	Week	Valid	Yes	

Below the table are buttons for 'Backup...', 'Set offline', and 'Settings...'. The 'Backup scheduler' is shown as 'Inactive'. The 'Restore segments' section below contains a table with the following data:

Segment ID	Status	Type	From	To	Unit	Flag	Backup created	New data
99999	Offline	Archive	7/13/2015 2:00 AM	7/27/2015 12:00 AM	Week (4)	Valid	8/18/2015 8:48 AM	No
99998	Offline	Archive	6/15/2015 2:00 AM	7/13/2015 2:00 AM	Week (4)	Valid	8/18/2015 8:50 AM	No

A 'Restore...' button is located at the bottom of the 'Restore segments' section.

When an archive segment is backed up, the Runtime data is stored in the backup file. The stored data includes:

- Process values
- Messages
- Configuration data on the process values and messages
- Aggregation data

---

**Note**

**No access to the database when executing the following functions in the segments:**

- During the preparation of a segment
  - During the backup of a segment
  - During the restoration of a segment
  - When the segment is set offline
- 

**Requirement**

- The segment to be backed up has the "Archive" status.
- When compression is enabled for the archive segments, the archive segments must be completely compressed prior to the backup.

**Backing up segments manually**

1. Select segment to be backed up in the "Archive segments" area.
2. Click the "Backup" button to launch backup.
3. Select the backup path for the backup file in the "Backup segment" dialog box that opens.
4. Click "Backup".

### Backing up segments automatically and setting them "Offline"

1. Click the "Settings" button in the "Archive segments" area.
2. Select the backup path for the backup file in the "Backup segment" dialog box that opens.

You can specify further identifiers and descriptions for the backup such as the name or number of the data medium.

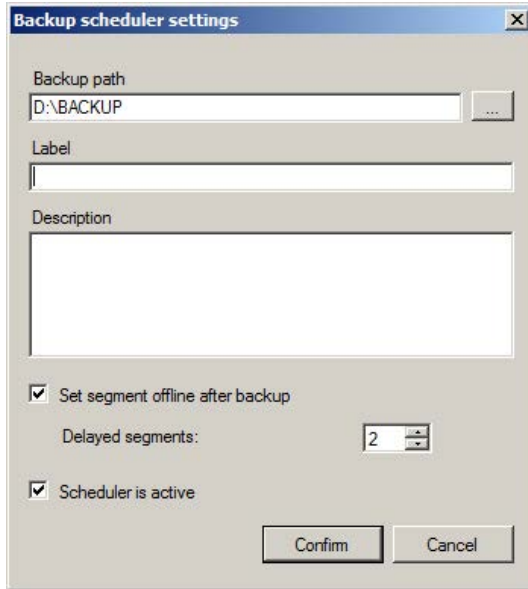

3. To set segments offline automatically after the backup, select the "Set segment offline after backup" option.
4. Set the number of delayed segments that are to remain available "Online". This extends the period during which you have read access to the archived data. If, for example, the segment size is "1 week" and the number of delayed segments is set to "2", the segments that are older than two weeks are set to offline.
5. You can enable automatic backup by selecting the "Scheduler is active" option.
6. Click "Confirm".

### 3.6.7 Restoring segments

If you want to access data that is stored in an archived and already swapped out segment, you must restore the segment. When restoring segments, you must select the backup file that matches the segment.

---

#### Note

If you have created multiple backups of a segment, you can only restore the most recent backup.

---

#### Requirement

- The matching backup files for the segments to be restored exist.
- The Process Historian is in the "Active" operating state.

#### Procedure

1. Select the "Backup/Restore" dashboard in the navigation of the Management Console.
2. Select the segment you want to restore in the "Restore segments" area.
3. Click on the "Restore" button.
4. In the "Restore segment" dialog, select the corresponding backup file for the segment you want to restore.
5. Click "Restore".

#### Result

The restored segments are displayed in the "Archive segments" area on the "Backup/Restore" dashboard.

You can access the data of the restored segment from the OS Server, OS Client or the Information Server.

---

#### Note

If you have created more than one backup of a segment, you can only use the last backup file created to restore the segment.

---

### 3.6.8 Set segments "Offline"

#### Introduction

When a runtime segment turns into an archive segment, you can back up the archive segment. After successful backup, you can set the archive segment from the Process Historian to "Offline". You can only set single segments to "Offline".

After setting a segment "Offline", only the information on restoring the backed up segment is stored in the Process Historian.

You can configure automatic setting to "Offline" together with the automatic backup.

#### Requirement

- A backup has already been created for the segment.
- The segment has been marked as "valid" in the "Backup/Restore" dashboard. A segment is marked as "invalid", for example, when additional Runtime data for the segment has accumulated after the creation of a backup. In this case, create a backup of the relevant segment again. You can find additional information on this in Backup of segments (Page 105).

#### Procedure

1. Select the "Backup/Restore" dashboard in the navigation of the Management Console.
2. In the "Archive segments" area, select the segment that you want to set to "Offline".
3. Click the "Set offline" button.
  - The entries of the selected segments are moved to the "Restore segments" view.
  - The storage space for these segments is released. You can check the amount of gained space in the "I/O systems" dashboard.

---

#### Note

##### Checking the disk space

To ensure enough free space for the Process Historian during operation, repeat these steps regularly.

---

#### Result

The segment is set to "Offline" in the Process Historian database.

### 3.6.9 Backing up the database

#### Overview

You can use the "Database backup" dashboard to create a full backup of the database with the time stamp of backup creation.

The "Current configuration and state" area displays the following information:

- Configured backup type
- Backup state: Progress of the backup copy
- Destination path of backup copies
- Free disk space
- Status

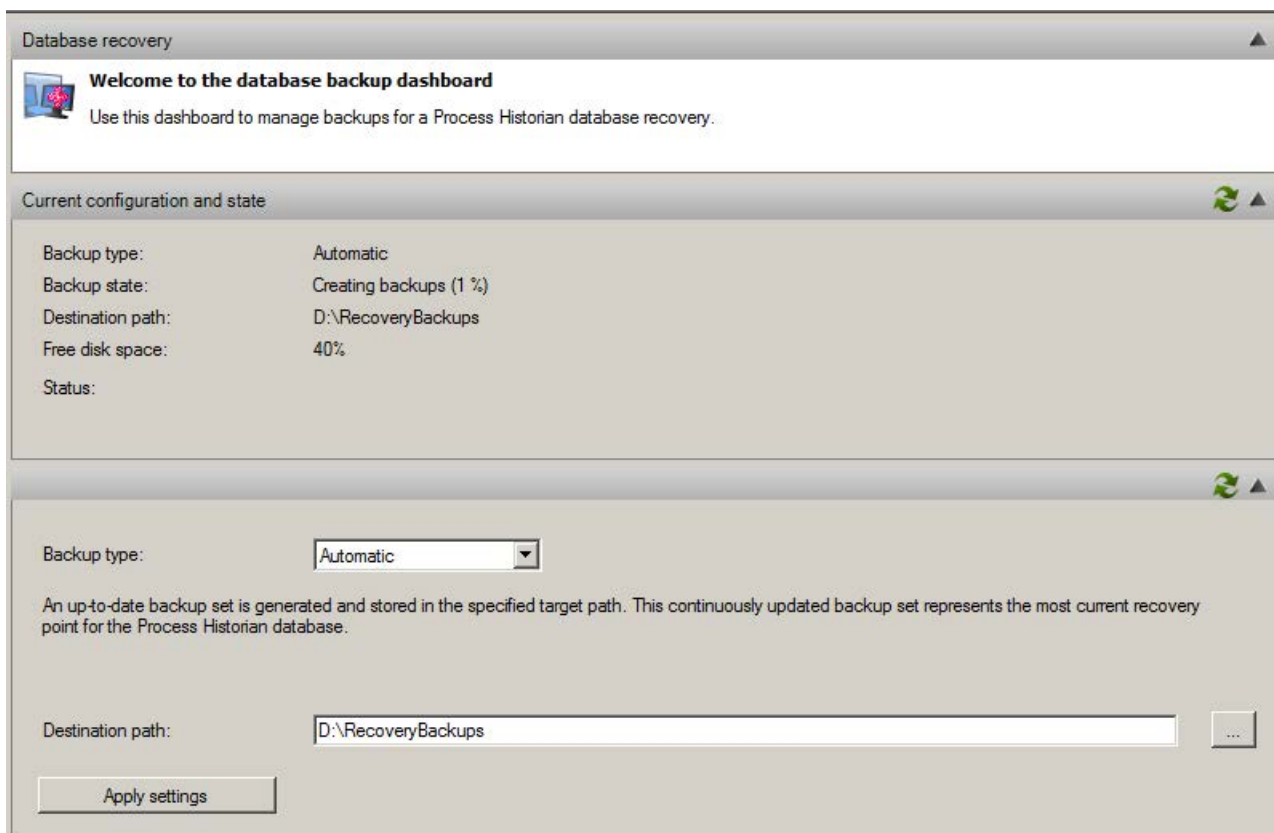

### Backing up the database

The data of the Process Historian database are stored in multiple data groups. A backup of the database consists of many individual created files that can contain the following:

- Backing up a single data group
- Backup of the current status of the transaction log after the backup of a data group

The files are created in a specified cycle. If all available data groups are stored in files, the status for this database is displayed as "100%". You can restore the database using these files.

You can select from three options for database backup in the "Settings" area:

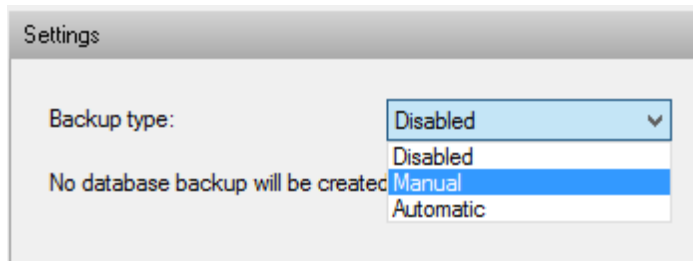

- "Disable": The "Database backup" function is disabled.
- "Manual": If all data groups have been saved once to files, the status is displayed as "100%". This completed the database backup. A recovery of the backed up files restores the data up to the time at which the last data group was saved.
- "Automatic": If all data groups have been saved once to files, the status is displayed as "100%". Recovery with the current database backup is possible only from this point in time.

In contrast to "Manual", a backup is then continuously made to other files for a data group that has been changed in the meantime. For this, the oldest backup of this data group is deleted so that the disk space does not increase infinitely. Recovery is always possible up to the time at which the last data group was saved.

### Storing the database backup

#### Defining the path

1. Enter the required drive in the "Destination path" field and a folder with the database name as path.
2. Click "Apply settings". In an overview window you will find the steps to be performed after confirmation.
3. Check your entries.
4. Confirm with "OK" if all the entries are correct. The database is backed up.





### Storage with automatic backup

The database backup is stored in the specified destination path for the first time. The next backup is saved in the same destination path and the previous backup is deleted. To prevent the loss of previous backups, enter a new destination path when you start the automatic backup.

Example:

The Process Historian-database has the name "HistorianStorage". The destination path is "D:\RecoveryBackups". The backup is saved in the destination path "D:\RecoveryBackups\HistorianStorage".

### Storage with manual backup

The database backup is stored in the specified destination path. The time stamp with date and time is part of the storage name of the backup.

Example:

The Process Historian database has the name "HistorianStorage". Backup was started on 31 May 2014 at 18:00 hours. This results in the following path and name for the backup: "D:\RecoveryBackups\20140531\_1800\_HistorianStorage".

You can save all future backups that you create manually in the same destination path. The existing backups are not changed or deleted.

## Storage medium

We recommend that you always store the database backup on a separate drive.

The following external drives can be used as storage media for the backups:

- USB hard disk
- Network drive via iSCSI. You can find information about iSCSI from Microsoft at:
  - [http://technet.microsoft.com/de-de/library/ee338476\(v=ws.10\).aspx](http://technet.microsoft.com/de-de/library/ee338476(v=ws.10).aspx)

Sufficient memory must be available on the selected storage medium for a complete backup.

---

### Note

#### Storage medium

You must not use a network enable or a path via UNC as storage medium for database backup. This applies both to the database backup and to the recovery of segments.

#### Memory requirements

If less than 20 GB are free on the drive, a warning is displayed on the control system.

A warning is output by the control system and the backup is aborted if there is less than 10 GB available on the drive.

---

### Incomplete backups

If the backup type is changed during backup creation, an incomplete backup cannot be resumed. Incomplete backups cannot be used for recovery.

If there are write errors for the database backup on the drive, it may not be possible to perform a restore.

### Database backup with redundant system

The "Database backup" function backs up a complete database. In a redundant system, the mirror takes over this task.

Manual database backup is possible in a redundant system.

### Recovery - Recovering a database

With a recovery, you restore the state of the database in the Process Historian to the time at which the data group has last been backed up to a file.

Recover the database using the "Database Recovery" program. Before recovery is started, the database backup is checked for completeness. The recovery process starts only if the backup is complete, which means the backup status is "100%".

Detailed steps for recovery are described in the section Recovering a database (Page 93).

---

#### Note

The name of the destination path is important in a recovery. The name must match the database name. Recovery is not possible when the path is renamed, and an error message is output.

---

### 3.6.10 Information on the plant structure of the projects

#### Introduction

The "Plant structure" dashboard displays all projects in a project tree that are currently integrated in the system. Detailed information is displayed for the individual projects, for example, for the saved process values and messages.

The basic area of the structure is automatically detected and displayed. You can manually add, rename or delete the extended structure. Use the buttons above the project tree to do this.

The screenshot displays the SIMATIC Process Historian interface, divided into two main sections: "Detailed plant structure information" and "Detailed communications information".

**Detailed plant structure information:**

- Projects:** A tree view showing the organizational structure. The root is "Organizational structure", which contains "PA\_WT\_MP", "OS(1)", and "SMOKE\_03\_047". Under "SMOKE\_03\_047", the project "DT-WC-005" is selected and highlighted in blue. Above the tree are buttons for "Add...", "Delete", "Rename", and "Merge".
- Detailed information:** A form for the selected project "DT-WC-005". It includes:
  - Name:** DT-WC-005
  - Type:** Physical Data Source (dropdown menu)
  - Description:** A large empty text area.
  - Apply:** A button at the bottom right.

**Detailed communications information:**

- Stored values:** A line graph showing data over time. The title is "Stored values" and the current rate is "24 Values/s". The x-axis is labeled "0 Values/s".
- Stored messages:** A line graph showing data over time. The title is "Stored messages" and the current rate is "7 Messages/s". The x-axis is labeled "0 Messages/s".

### Plant structure detection

- PCS 7 projects
    - WinCC projects
- PC

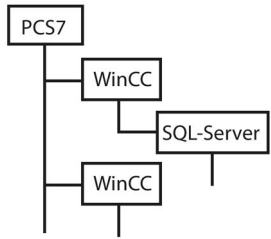

You can manually add, edit or remove the following expanded structure:

- Company
- Location
- Building
- Corridor
- Room
- PCS 7

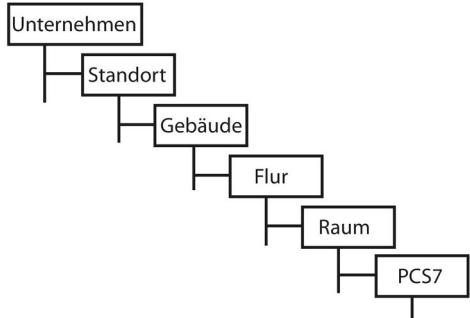

The nesting depth of the structure can be expanded as necessary.

### Detailed project information

The following detailed information on the project is displayed when you select a project:

- Name
- Type
- Description

You can change and confirm the description and type of the project.

### Merging a project

You merge projects when there are duplicate project entries in the structure tree. Duplicate entries can be caused, for example, when an image of the OS server was installed again after a hardware fault.

You can use the "Merge" button to combine duplicate entries so that they form a single entry again in the system structure.

Check for duplicate entries after merging the project tree. Delete duplicate entries from the project tree.

Do not use "merge" when the systems of multiple projects loaded and used in Runtime on an OS server, for example, on a PCS 7 engineering station. For additional project nodes may be present, but you are not allowed to merge them.

## 3.6.11 Information on the data sources

### Introduction

The "Data sources" dashboard shows the state of the computers that are connected in projects with the Process Historian Server in an overview. You can delete the configuration data of a selected project. In order to prevent deletion, you can set a lock.

### Information about the connected data sources

The "Data source" dashboard shows the following information about the connected data sources:

Locked	Computer name	Project	Redundancy state	Sending	Last lifebeat	Last alarm data	Last tag data	Last alarm configuration	Last tag configuration
Yes	VM-JK-W7-01	Thor	StandAlone	Yes	19.01.2016 12:36:05	19.01.2016 08:10:06	19.01.2016 12:33:42	12.01.2016 11:15:40	12.01.2016 11:15:44
Yes	S74C	Standardweb	StandAlone	Yes	19.01.2016 12:36:05	19.01.2016 11:07:16	19.01.2016 12:27:59	12.01.2016 11:12:43	12.01.2016 11:14:29
Yes	OPCSERVER6	Odin	Master	Yes	19.01.2016 12:36:05	11.12.2015 07:49:24	19.01.2016 12:16:49	12.01.2016 13:50:30	12.01.2016 13:50:35

- Locked:
  - No: The project is not locked. The project data can be deleted. You can only delete the project or data source after no data transfer has taken place for approximately 15 minutes.
  - Yes: The project is locked. You can deactivate the lock.
- Name of the connected computer
- Name of the project included in the Process Historian
- State of the redundancy, for example "Stand-alone" or "Master"
- Sending:
  - Yes: The connection between OS and the Process Historian is established. The OS can send data to the Process Historian. The last sending of the data is visible in the columns lying further away.
  - No: No connection between OS and the Process Historian is established. Therefore, no data is supplied to the Process Historian.
- Last lifebeat: Time stamp of the last successful check of contact between the computer and Process Historian.
- Last alarm data: Time stamp of when the last alarm data was transferred from the computer to the Process Historian.
- Last process value data: Time stamp of when the last measuring value data was transferred from the computer to the Process Historian.
- Last alarm configuration: Time stamp of the last time the configuration data for the messages was transferred from the computer to the Process Historian.
- Last process value configuration: Time stamp of the last time the configuration data for the measured values were a transferred from the computer to the Process Historian.

You can sort the rows of the table according to a column selection.

The values of the "Last lifebeat", "Last alarm data" and "Last process value data" columns are marked with respect to their relevance:

- Blue marking: No data has been sent from the client to the Process Historian during the last 10 minutes .
- If "Last lifebeat" is highlighted in color, the associated computer is no longer running.

---

**Note**

The time stamp in the columns "Last alarm data" and "Last process data" does not always match the time stamp of the data itself. The time stamps can be significantly different from each other if, for example, the connection between OS and Process Historian was faulty beforehand.

---

### Deleting a project included in the Process Historian

You can delete the configuration data of a selected project by using the "Delete" button. The data can no longer be read. The computer is removed from the plant structure and no longer displayed in the "Plant structure" dashboard. A prompt is displayed in which you have to confirm deleting.

You may only delete projects whose computers have been removed from the system. Process Historian checks that the computer has not sent any data to the Process Historian in the last 15 minutes.

You can only delete unlocked projects for which "No" is entered in the "Locked" column.

### Locking a project included in the Process Historian

You can lock a project in order to prevent deleting of the project data. Click "Lock". A prompt is displayed in which deleting has to be confirmed.

A locked project can be unlocked by selecting the project and clicking "Unlock".

## 3.6.12 Information on the storage system

### Overview

The "I/O Systems" dashboard displays the entire storage system to which there is read and write access. All hard drives integrated in the system are displayed, including the hard drives that do not contain archive data.

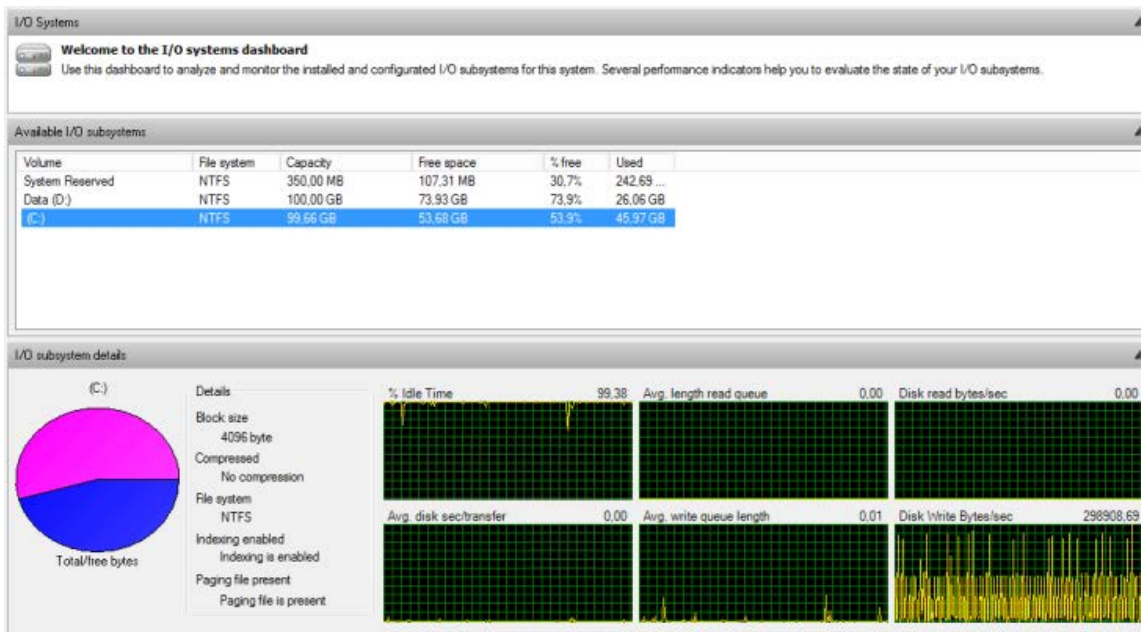

The "I/O Systems" dashboard displays the following information on the storage system:

- Name and drive letter of the hard drives
- File system
- Total storage space: Capacity
- Absolute available storage space
- Free storage space as percentage
- Absolute storage space used

The states of the input and output devices are graphically monitored by the system. If you select a drive, you receive the following detailed information on the selected drive:

- Idle time of the hard drive: Idle time
- Average duration per transfer
- Average length of queue for read access
- Byte per second with read access to data medium
- Average length of queue for write access
- Reading speed in Byte per second
- Writing speed in Byteper second

## Storage space monitoring

On the OS, PH-Ready monitors the storage space on the system drive where the cache is located.

On the Process Historian server, the Maintenance Service monitors the storage space on the following drives:

- System drive
- Drive where the transaction log is located
- All data drives on which the Process Historian database is distributed

A warning is sent to WinCC if the following occurs:

- The free space falls below the limit of 100 GB and is less than 20% of the drive capacity.
- The free space on the system drive falls below the limit of 200 GB and is less than 40% of the drive capacity.
- The space is insufficient for at least three newly created segments.

The Process Historian server switches to the "Locked" state when the following occurs:

- The free space falls below the limit of 50 GB and is less than 10% of the drive capacity.
  - Hard drive up to 500 GB: Free space < 10 %
  - Hard drive larger than 500 GB: Free space < 50 GB
- The free space on the system drive falls below the limit of 100 GB and is less than 20% of the drive capacity.
- The space is insufficient for at least one newly created segments.

## Minimizing memory requirements

You have the following options to minimize memory requirements or increase the memory space:

- Swap out archive segments from the Process Historian database early.
- Set the number of future segments to the minimum value of 1 segment. Consequently, the required hard disk space is only reserved for one future segment.
- Set the total number of runtime segments to the minimum value of 4 segments. This means that the segments are compressed at the earliest time possible.
- The number of archive segments that are reserved as non-compressed must be set to "0". This means compression of the archive segments can start immediately once a segment has been marked as archive segment.
- Make space available on the drive by deleting log files, temporary files and other files no longer needed.



### 3.6.13 Information on the licenses

#### Overview

The "Licensing" dashboard gives you an overview of the licenses used and available in the system.

The availability of the Process Historian licenses is displayed.

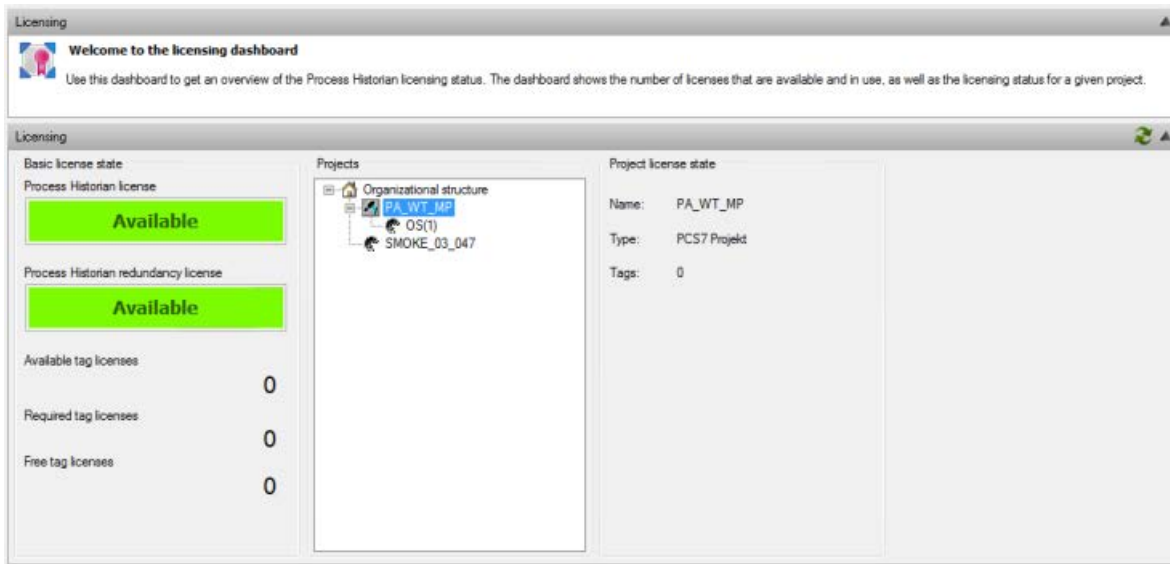

You also obtain detailed information about the states of the tag licenses:

- Available
- Required
- Free

The Process Historian requires no tag licenses for the PCS 7/ WinCC sources.

When you select a project, you receive information on the project-specific license status with the following information:

- Project name
- Project type
- Number of tags

### 3.6.14 Diagnostics of the Process Historian

The upper area of the "Diagnostics" dashboard displays the 1000 most recent diagnostic messages from the Process Historian event log.

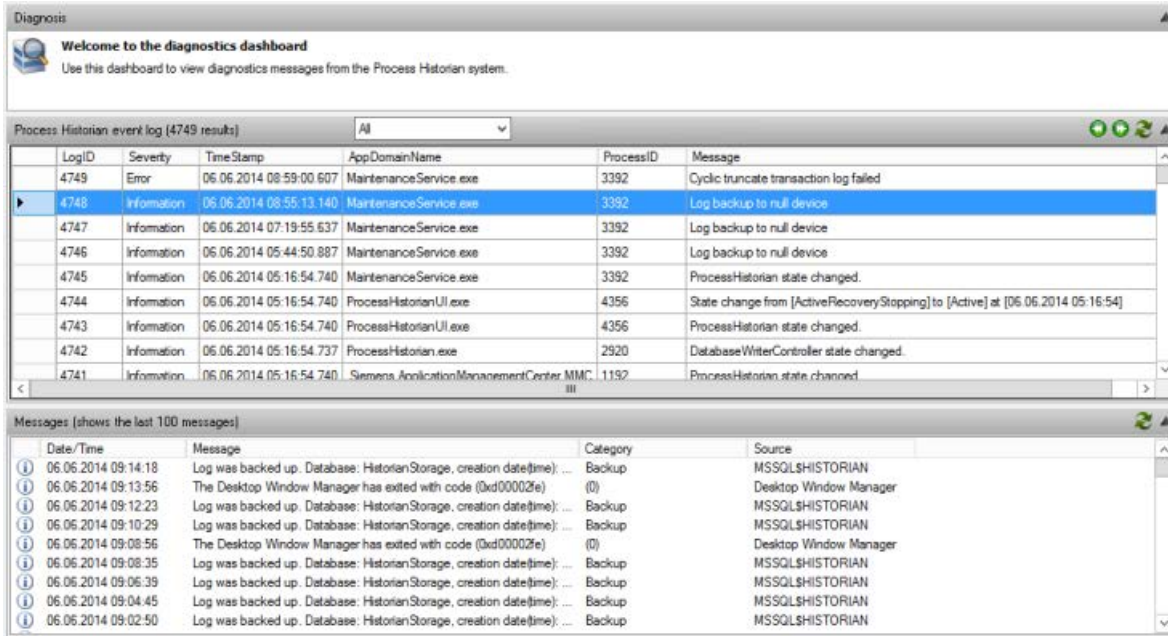

The event log of the Process Historian contains the following information:

- Log entry ID
- Severity of the message
- Time stamp
- Name of application domain
- Process ID
- Message

The lower section of the "Diagnostics" dashboard includes the last 100 entries from the event log for Windows applications. The following information is displayed:

- Time stamp
- Message
- Category
- Source

## 3.6.15 Backing up and restoring batch data

### Overview

You can use the "SIMATIC Batch Backup/Restore" dashboard to back up and restore the batch data archived by the SIMATIC Batch server with the Process Historian. The data include the batch information provided by the SIMATIC Batch server and the runtime information during batch creation.

You can swap out the batch data manually or automatically to backup files. After successful backup, you can delete the backed-up batch data from the Process Historian. If you need the swapped out batch data in the Process Historian again, use "Restore" to make the selected batch data once again available to OS servers, OS clients or the Information Server.

The archive tags and alarms supplied by the OS computers from the batches are archived in separate segments in the Process Historian. You backup and remove these segments with the "Backup/Restore" dashboard.

### Requirement

- There are SIMATIC Batch files in the Process Historian.
- The tree view of the plant structure corresponds to the respective batch project.

### Selecting batch data for backup

1. In the "SIMATIC Batch data" navigation pane, select the data you wish to back up from all archived batch data.

The data are displayed in the following hierarchy:

- SIMATIC Batch system
- Order category
- Order
- Batch

You can expand/collapse and select/deselect individual elements of the hierarchy. The selection of a parent node also selects all elements below.

2. The table displays the selected batch data with the properties. When you click on the header of one of the displayed property columns, the entries in the table are sorted according to this property. The "Backup created" column shows if the respective batches have been backed up and their status.



The screenshot shows the 'Batch selection' window. On the left is a tree view of the 'Simatic batch data repository' with nodes for 'Process Historian Archive', 'SB8\_2101-612343-33 (V8\_0)', 'Temp', and 'Dauerfest 2014->2015'. The 'Temp' node is expanded, showing a list of batches. On the right is a table with columns: System, System version, Order category, Order, Batch name, Batch ID, Product, and Master recipe. Below the table are buttons for 'Add', 'Remove', and 'Remove all'. At the bottom left, there is a 'Batch count' section showing 'Total: 28' and 'Backed up: 0'. At the bottom right, there are 'Tasks' buttons for 'Backup', 'Delete', and 'Restore', along with a 'Configure' button and a 'Task status: Disabled' indicator.

System	System version	Order category	Order	Batch name	Batch ID	Product	Master recipe
SB8_2101-61234...	V8_01_01	Temp	temp 1	Batch 1	89	Paint	PH2014+SP1
SB8_2101-61234...	V8_01_01	Temp	temp 1	Batch 2	90	Paint	PH2014+SP1
SB8_2101-61234...	V8_01_01	Temp	temp 1	Batch 3	91	Paint	PH2014+SP1
SB8_2101-61234...	V8_01_01	Temp	temp 1	Batch 4	92	Paint	PH2014+SP1
SB8_2101-61234...	V8_01_01	Temp	temp 1	Batch 5	93	Paint	PH2014+SP1
SB8_2101-61234...	V8_01_01	Temp	temp 1	Batch 6	94	Paint	PH2014+SP1
SB8_2101-61234...	V8_01_01	Temp	temp 1	Batch 7	95	Paint	PH2014+SP1
SB8_2101-61234...	V8_01_01	Temp	temp 1	Batch 8	96	Paint	PH2014+SP1
SB8_2101-61234...	V8_01_01	Temp	temp 1	Batch 9	97	Paint	PH2014+SP1
SB8_2101-61234...	V8_01_01	Temp	temp 1	Batch 10	98	Paint	PH2014+SP1
SB8_2101-61234...	V8_01_01	Dauerfest 2014->...	2. Woche	Batch 6	51	Paint	PH2014+SP1
SB8_2101-61234...	V8_01_01	Dauerfest 2014->...	2. Woche	Batch 7	52	Paint	PH2014+SP1
SB8_2101-61234...	V8_01_01	Dauerfest 2014->...	2. Woche	Batch 8	53	Paint	PH2014+SP1
SB8_2101-61234...	V8_01_01	Dauerfest 2014->...	2. Woche	Batch 9	54	Paint	PH2014+SP1
SB8_2101-61234...	V8_01_01	Dauerfest 2014->...	3. Woche	Batch 10	55	Paint	PH2014+SP1
SB8_2101-61234...	V8_01_01	Dauerfest 2014->...	3. Woche	Batch 11	56	Paint	PH2014+SP1

3. Click "Add" to display more data for the displayed batch data which meet specific criteria. For example, display batches with a specific start time.

- Select the check boxes of the criteria by which you wish to filter the batch data. Enter the specific criteria or select the criterion from the drop-down list. You can use the wildcards "\*" and "?" in text fields. You do not have to set the wildcards at the beginning or end of an entered text. An "\*" is automatically added here. You cannot use wildcards in number fields and selection boxes.

- Click "OK". The batch data which meet the criteria are displayed in the table.
- If you want to remove individual rows in the table, click "Remove". Or click "Remove all" to remove all entries from the table. You can now select batch data once again that you want to display and back up.

### Backing up batch data manually

You can manually back up the batch data displayed in the table. Each batch is stored in its own, compressed backup file.

- In the table, select the rows of the batches with the data you want to back up. Use "Ctrl A" to select all batch data of the table.
- In the "Tasks" area, click on the "Backup" button.
- Enter the path for the backup files in the dialog box. You can select a local directory as the backup location.
- Click "OK". You cannot execute any other task in the dashboard during backup.

**Result**

The batch data are saved to the specified path. The file name of the backed-up batches has the following components:

- Name of the Batch process cell
- Batch name
- Start time

The number of backed-up batches is updated in the "Number of batches" area of the dashboard. The "Backup created" column in the table indicates the state in which the batches were backed up.

**Backing up batch data automatically**

You can use a scheduler to automatically back up all batch data archived in the Process Historian when the archived data have reached the final state in the Process Historian. The scheduler checks if there are batches to be backed up in the configurable time period. Each batch is stored in its own, compressed backup file.

1. In the "Tasks" area, click on the "Configure" button. The "Scheduler Configuration" dialog opens. The configuration refers to all batch data that have reached the final state.

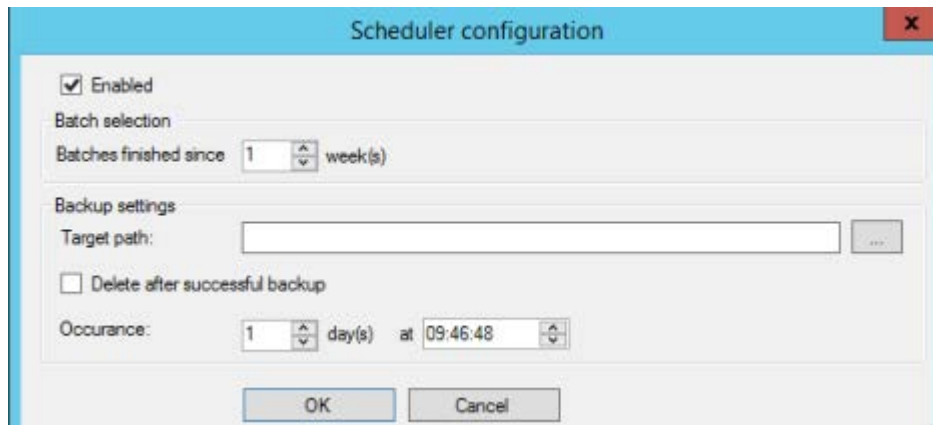

2. Select the "Active" check box so that the scheduler can back up the batches automatically. If you no longer wish to use the scheduler for an automatic backup, clear the "Active" check box.
3. In the "Batch selection" area, select the interval as of which the batches archived in the final state are to be backed up by the scheduler. For example, select all batches for backup that reached the final state of archiving one week before the start of the automatic backup. The backup of the archived batches should be coordinated with the backup of the segments with the archive tags and alarms of the batches.

4. Enter the path for the backup file. All backup files of the batches are stored in the folder.
5. If you have selected the "Delete after successful backup" check box, the batch data are removed from the Process Historian after the successful backup.
6. For "Run", select after how many days and at what time the scheduler is to check if the criterion for an automatic backup has been met. The archived data which meet the criterion are then backed up.
7. Click "OK" to save the scheduler configuration.

### **Result**

When the scheduler is active, the batch data are backed up automatically. The status of the scheduler is displayed as "Active" in the "Tasks" area of the dashboard.

When the scheduler is deactivated, the batch data are not backed up automatically. The status of the scheduler is displayed as "Inactive" in the "Tasks" area of the dashboard.

You can change the configuration of the scheduler at any time without affecting the ongoing backup process. The updated scheduler is not used until the next time you run the backup.

## **Manually deleting backed-up batch data from the Process Historian**

### **Requirement**

- The archiving of the batch data has reached the final state in the Process Historian.
- The batch data have been backed up successfully.

### **Procedure**

1. Click "Delete".  
The batch data selected in the table are removed from the Process Historian. You cannot execute any other task in the dashboard during deletion. The batches are removed from the table and the total number of batches is updated in the "Number of batches" area.

### Restoring backed-up batch data

#### Requirement

- There are backup files with the batch data to be restored.
- The backed-up batch data are no longer available in the Process Historian.

#### Procedure

1. In the "Tasks" area, click on the "Restore" button.
2. In the dialog box, select the backup file(s) of the batch data you want to restore.
3. Click "Open". A window opens to check the properties of the batch data and the path of the backup file.

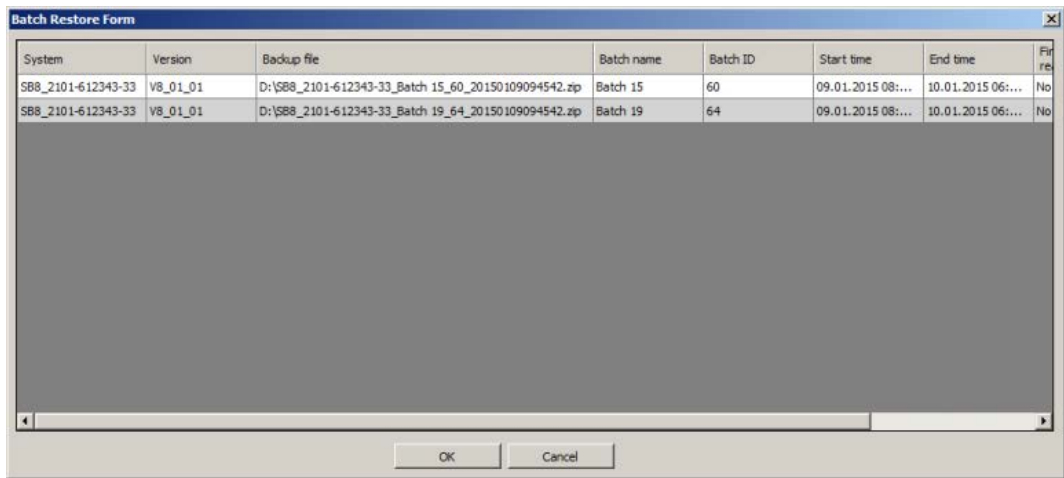

4. Select the batches to be restored.
5. Click "OK".
6. Restore the segments with the corresponding process values and messages for the time period.

#### Result

The batch data from the backup file is transferred back to the Process Historian. The restored data are shown in the table. The "Backup created" column shows the time when the backed-up batches were restored.

You can now access the restored batch data from the OS server, OS client or the Information Server.



## 3.7 Migrating archive data from projects

### 3.7.1 Overview

#### Introduction

This section describes the migration of the following projects to the current Process Historian:

- WinCC V7
- Central Archive Server (CAS)
- StoragePlus
- Process Historian

You can find a compilation of migratable data sources in the following graphic.

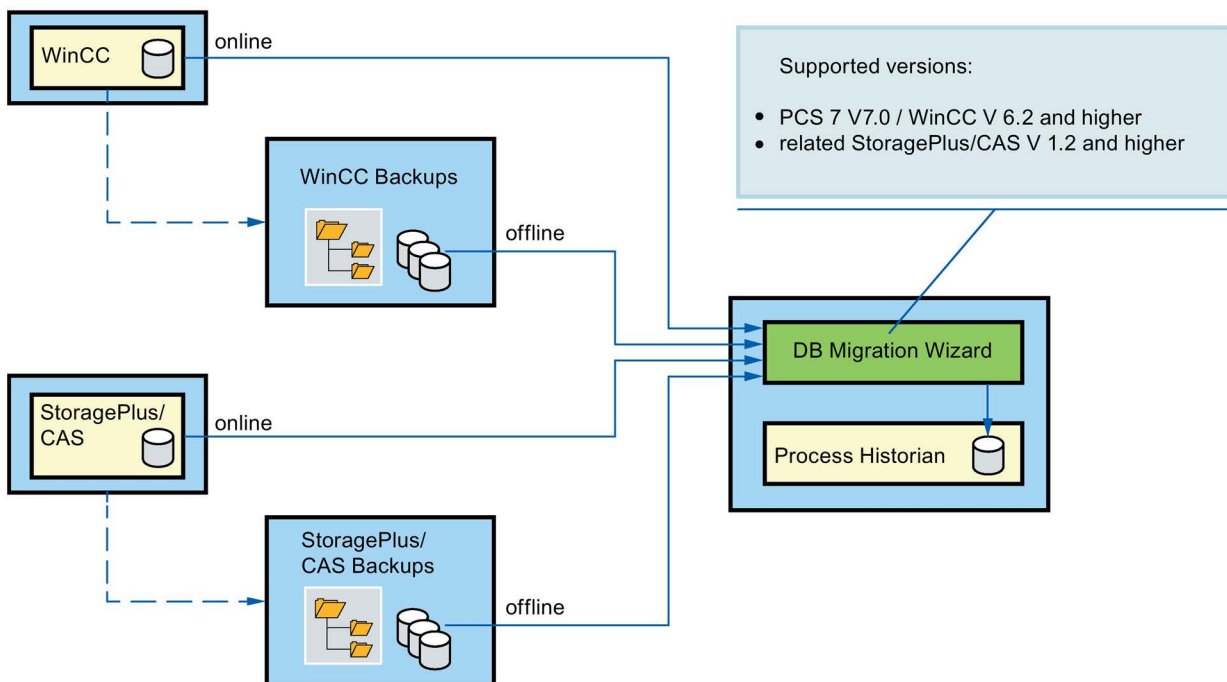

### 3.7 Migrating archive data from projects

You can migrate process data from the following sources:

- CAS project online (Page 132)
- CAS project backup (Page 136)
- WinCC project online (Page 139)
- WinCC project backup (Page 142)
- Process Historian project online (Page 146)

The data from the CAS and WinCC sources can be migrated online and offline. The data from the Process Historian source can only be migrated online.

---

#### **Note**

##### **Migration time**

Depending on the data volume, the time needed for the migration may take from a few minutes to several days.

---

Log entries for each migrated WinCC segment or CAS segment are created in the Process Historian database. This is associated with the following advantages:

- You can resume an interrupted Migration again at the most recently used location.
- If a segment has already been completely migrated, it is marked accordingly. This segment cannot be migrated again, duplicate data entries are avoided.
- You do not have to migrate all segments at once. You can perform the migration of segments not yet migrated at anytime.

The only data migrated to the Process Historian database are those which precede the date on which the corresponding WinCC project sent data to the Process Historian for the first time. This prevents the storage of duplicate data.

---

#### **Note**

##### **Duplicate alarms**

The Process Historian checks during migration if backup segments of the "Alarm Logging" type have been created twice in the Process Historian in the following cases:

- The migration for the same backup segment has already been started, stopped and started again.
- A backup segment is migrated, although an identical online segment has already been migrated.

Duplicate messages with identical contents are then created with a new Message UID in the Process Historian database.

---

## System requirement

The computer with which you perform the migration must meet the following conditions:

- The hardware requirements from the installation instructions must be met.
- The software requirements from the installation instructions must be met.
- The Process Historian must be enabled.
- The free space on the drive must be large enough to accommodate the new data.
- The latest version of the Process Historian must be installed.
- The required licenses must be available.
- Online segments can only be migrated if the corresponding output system is active.
- Backup segments can only be migrated if the path on which the backup segments are located is available.

## Database migration wizard

To migrate data, open the Database Migration Wizard, "ProcessdataMigrator.exe". The Database Migration Wizard is installed together with the Process Historian on the same computer. The "ProcessdataMigrator.exe" is available in the Process Historian installation path under "%Siemens%\ProcessHistorian\bin".

The Process Historian must be started in order to start the Data Migration Wizard.

The migration procedure is very similar for the five data sources, but differs somewhat in detail:

1. First, select the data source and the segment type.
2. Select the path and the segments. The segments consist of tag data and message data.
3. Select the desired segments and start the migration process.
4. Before starting the actual migration process, a summary screen is displayed, which you should check.
5. If all the selected segments are correct, start the migration process.
6. An overview with green check mark indicates the current progress of the migration.
7. If all entries are green, the migration is complete and the migrated data are available. Verify that you have access to the migrated data. Use a WinCC Trend Control, Alarm Control or the Information Server for this.

## 3.7.2 Migrating

### 3.7.2.1 CAS project online

#### Migrating CAS project online

1. Start the database migration wizard.
2. Select the source and the segment type.

In this case, online segments of a StoragePlus project or CAS project are migrated.

##### Source

Select the source and segment type.

1. Select source

- StoragePlus / CAS
- WinCC / PCS 7.0S
- Process Historian

2. Select segment type

- Online
- Backup

Cancel Previous Next Finish

- The dialog for the source path shows the available SQL instances in the network.

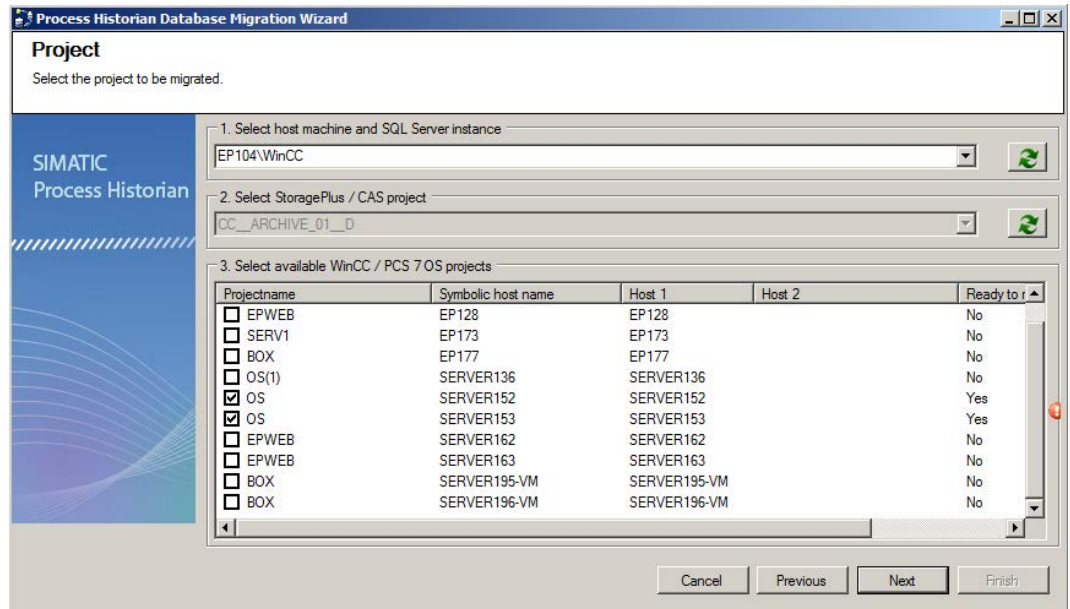

Select the required computer in the selection list. The available projects are displayed.

- Select the required project.
- Select the segments you want to migrate. Disable all other segments. Use the shortcut menu to select and remove entries.

Three data segments of the Tag Logging type were selected in this example.

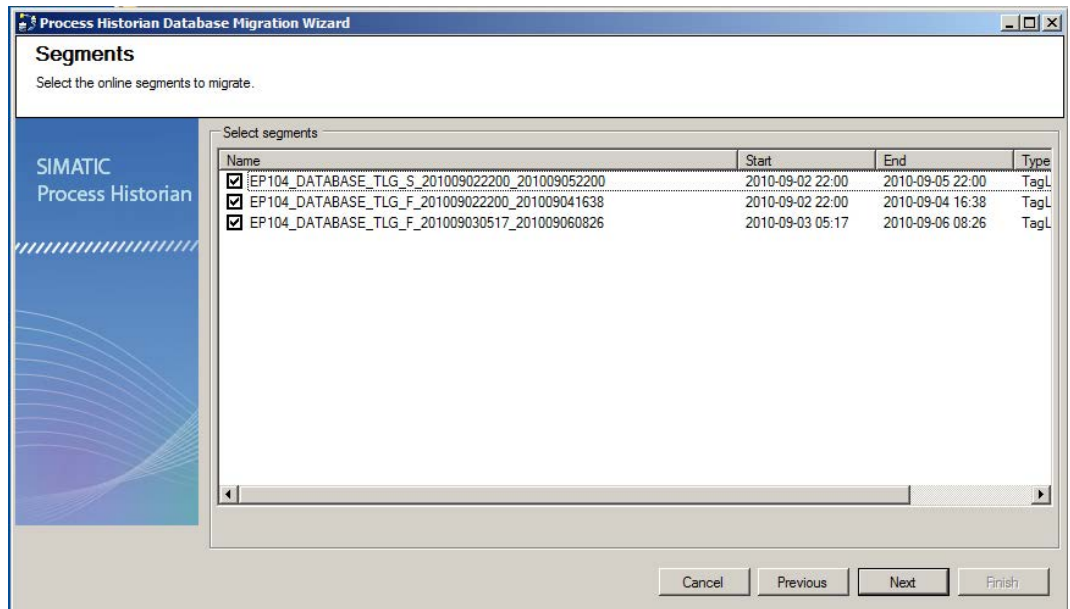

6. Check the displayed summary of the migration.

If the summary is correct, start the migration.

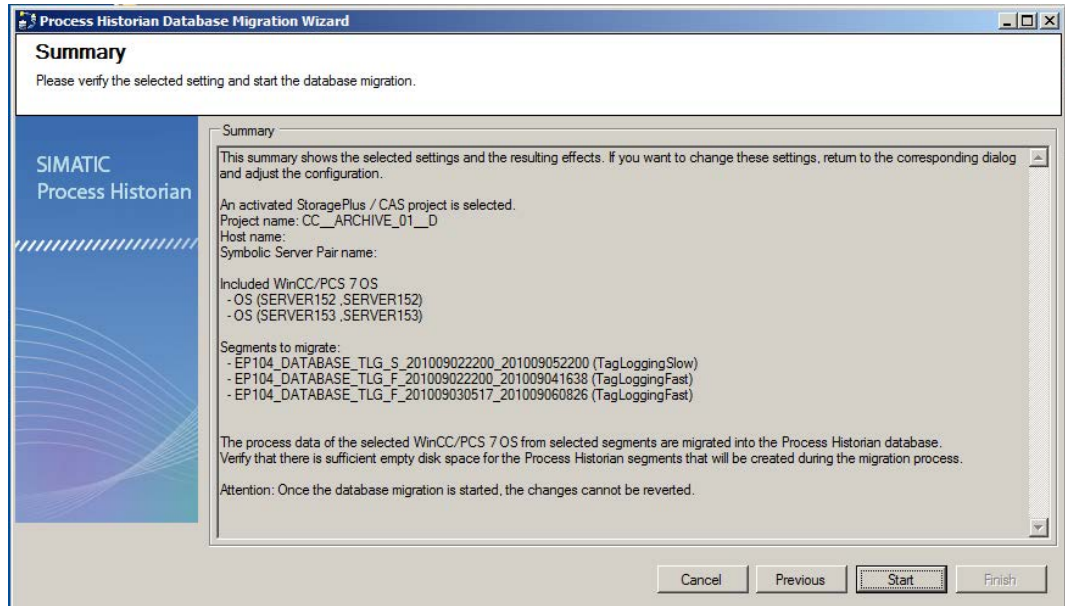

7. The migration progress is displayed.

When the migration is complete, stop the database migration wizard by clicking "Finish".

### Migration from segments that are older than the versions WinCC V7.0 SP3 or PCS7 V8.0

In the case of a migration from segments that are older than versions WinCC V7.0 SP3 or PCS7 V8.0, the backup segment does not contain all information required for the migration.

This information therefore has to be provided manually to the ProcessDataMigrator. The following two dialogs appear during the migration:

- Selection of a code page for reading out the message texts
- Selection of a WinCC configuration file with the Step7 text library

#### Selection of a code page for reading out the message texts

This dialog is used to select a character set table in order that the stored message texts of alarms can be correctly read out and displayed.

The default setting "Western Europe (ISO)" can be used for all Western European languages and the American region.

A different character set table must be selected for the Asian region. To check whether the messages were correctly interpreted, use the "Preview with code page number".

### Selection of a WinCC configuration file with the Step7 text library

This dialog appears when the message texts in the segment contain format characters from the Step 7 text library. If the dialog appears during the migration, you have to select the WinCC configuration database that contains the table "CC\_Step7Text".

The two output fields are empty in the first segment in which a selection is required. You must specify the corresponding selection. The manual selection is applied in any further occurrence.

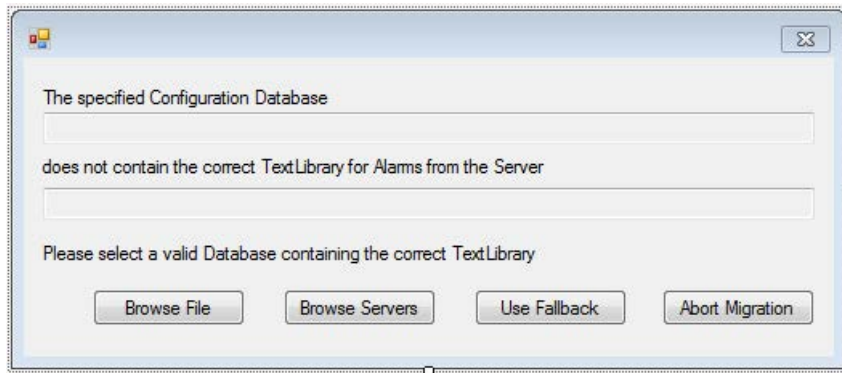

Use the "Browse File" and "Browse Servers" to select the WinCC configuration database.

During the selection of a file via "Browse File" you must select a database which is, e.g., located in a created project backup and not attached to an SQL server. You must select a database file of type "<...>.mdf".

If the segments originate from WinCC Runtime, you can select the OS server with the corresponding database under "Browse Servers". In this case the database has to be attached in the SQL server, which means that the project has to be open.

If the configuration file is no longer available, you have the option of importing the Step7 texts without resolution. This "fallback" means that the messages are saved with the appropriate format characters.

## Result

The selected data from the CAS project online was migrated to the current Process Historian database.

### 3.7.2.2 CAS project backup

#### Migrating CAS project backup

1. Start the database migration wizard.
2. Select the source and the segment type.

In this case, backup segments of a StoragePlus project or CAS project are migrated.

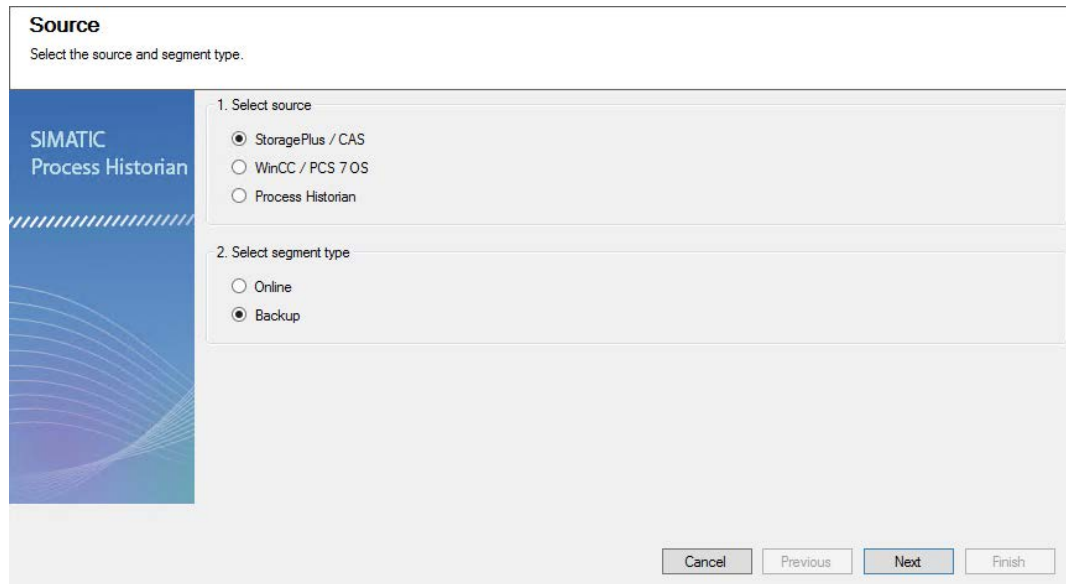

3. In the following dialog, select the "Add segments" or "Add folders" entry under "Add" in the shortcut menu of the displayed field. Use the shortcut menu to select and remove entries.
4. Select the required segments and confirm with "Open".

In this example, an Alarm Logging segment is migrated from the project.

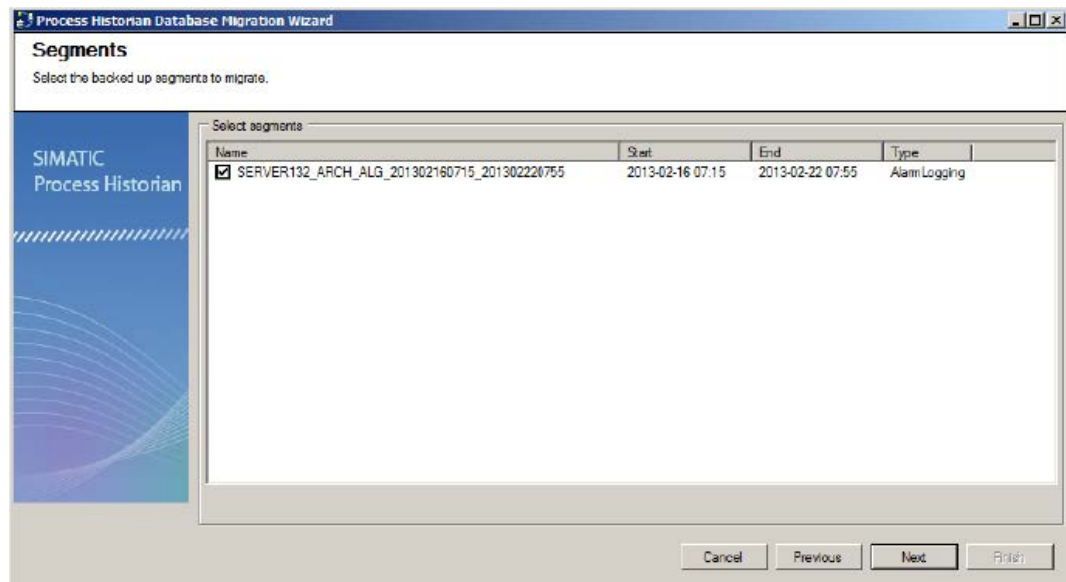



- The database migration wizard indicates that the segment was found in the backups.  
Click in the "Project in Process Historian" column to assign the storage location for the migrated project.

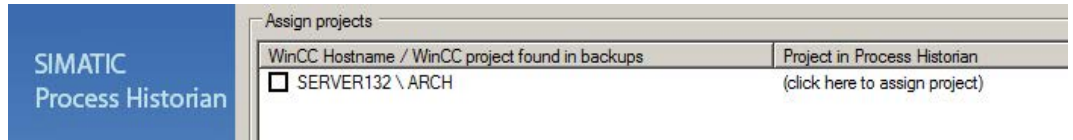

- The plant structure opens.  
Select the path in which you want to save the migrated project.

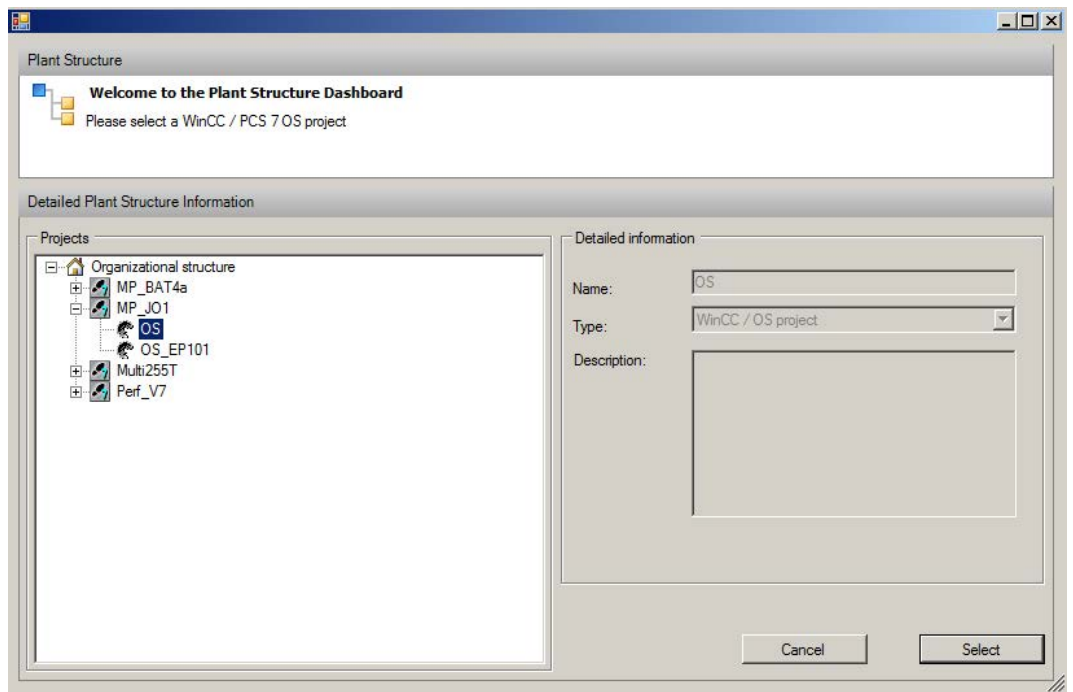

The selected path is displayed.

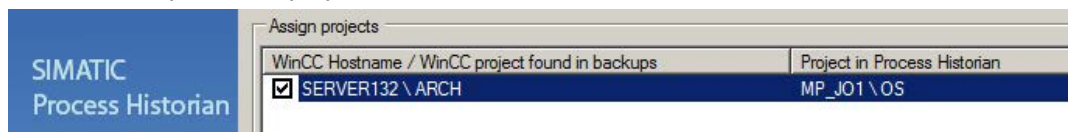

7. Check the displayed summary of the migration.

If the summary is correct, start the migration.

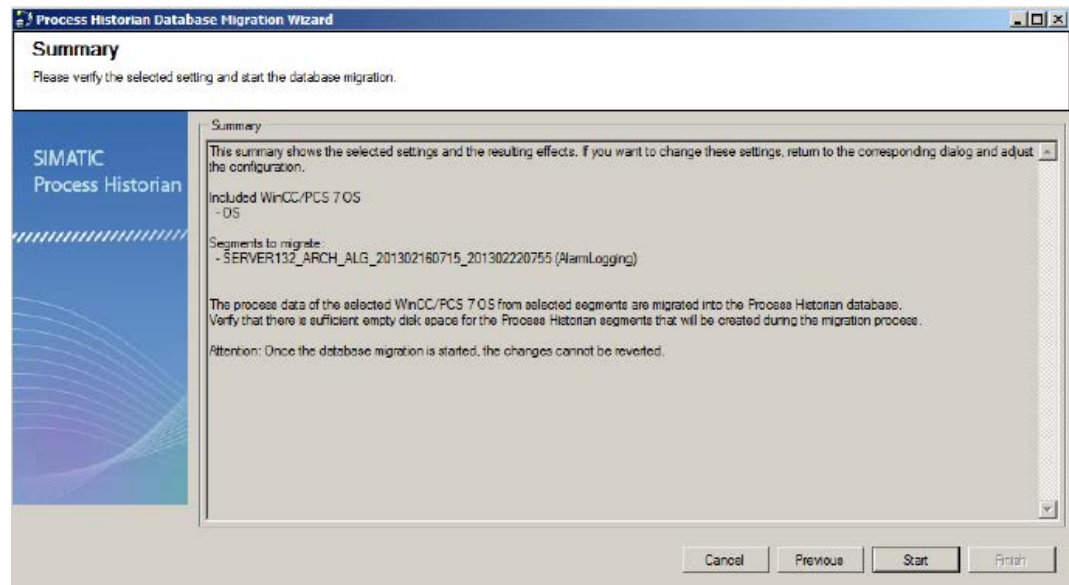

8. The migration progress is displayed.

When the migration is complete, stop the database migration wizard by clicking "Finish".

## Result

The selected data from the CAS project backup was migrated to the current Process Historian database.

### 3.7.2.3 WinCC project online

#### Migrating a WinCC project online

1. Start the database migration wizard.
2. Select the source and the segment type.

In this case, online segments of a PCS 7 project or WinCC project are migrated.

#### Source

Select the source and segment type.

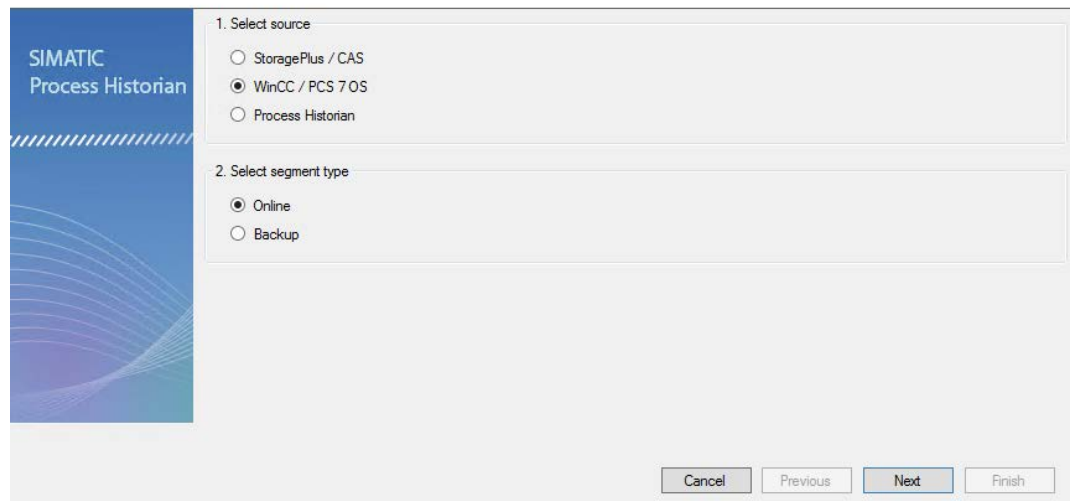

3. The dialog for the source path shows the available SQL instances in the network.  
Select the PC with the required project from the selection list.

The selected WinCC project is displayed in the entry field.

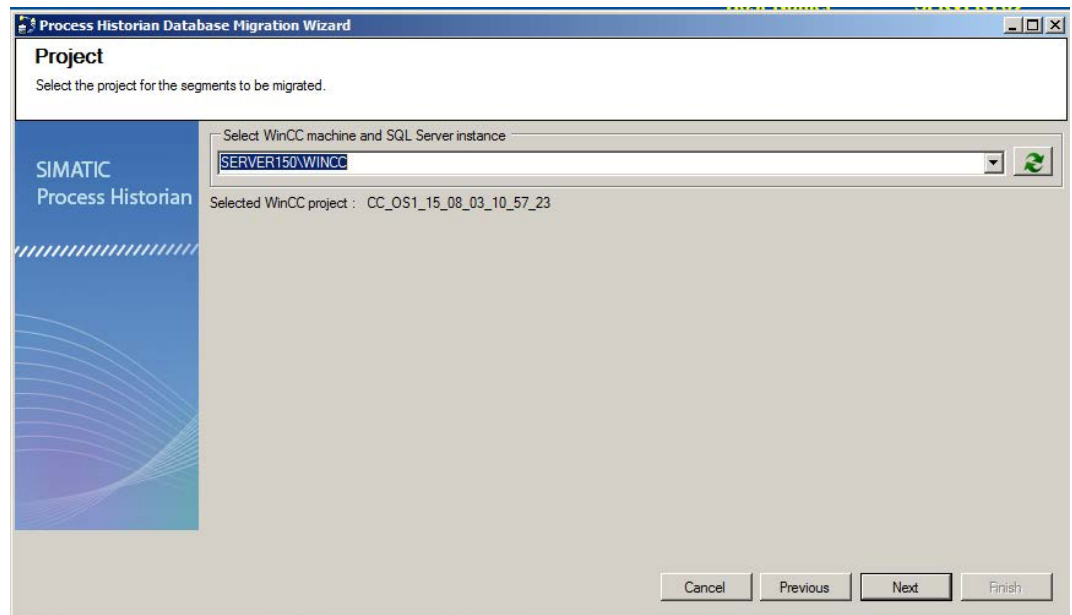

3.7 Migrating archive data from projects

- 4. Select the segments you want to migrate. Disable all other segments. Use the shortcut menu to select and remove entries.

Three data segments of the Tag Logging type and two data segments of the Alarm Logging type were selected in this example.

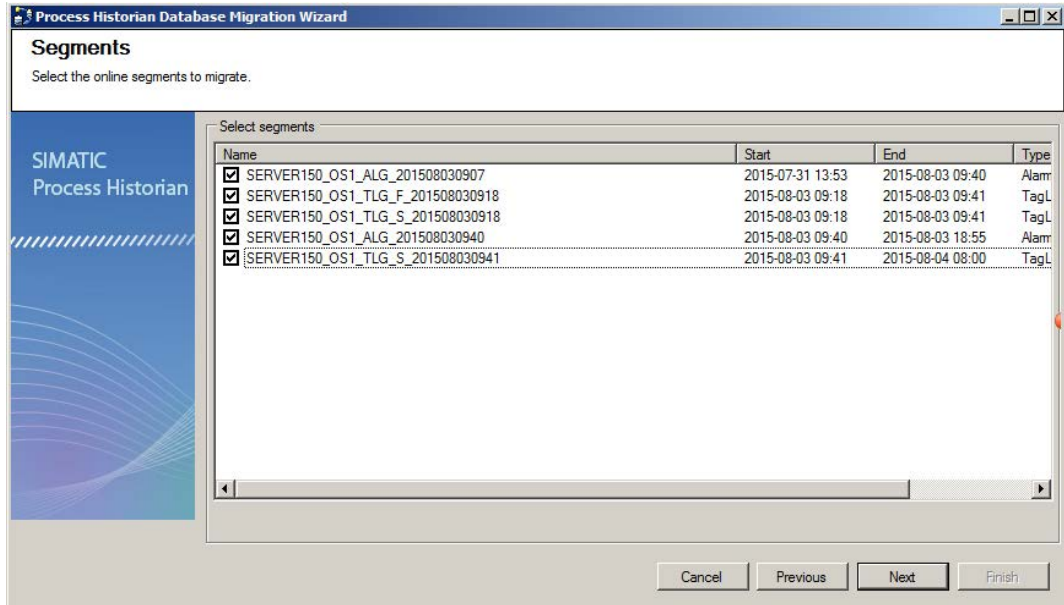

- 5. Check the displayed summary of the migration.

If the summary is correct, start the migration.

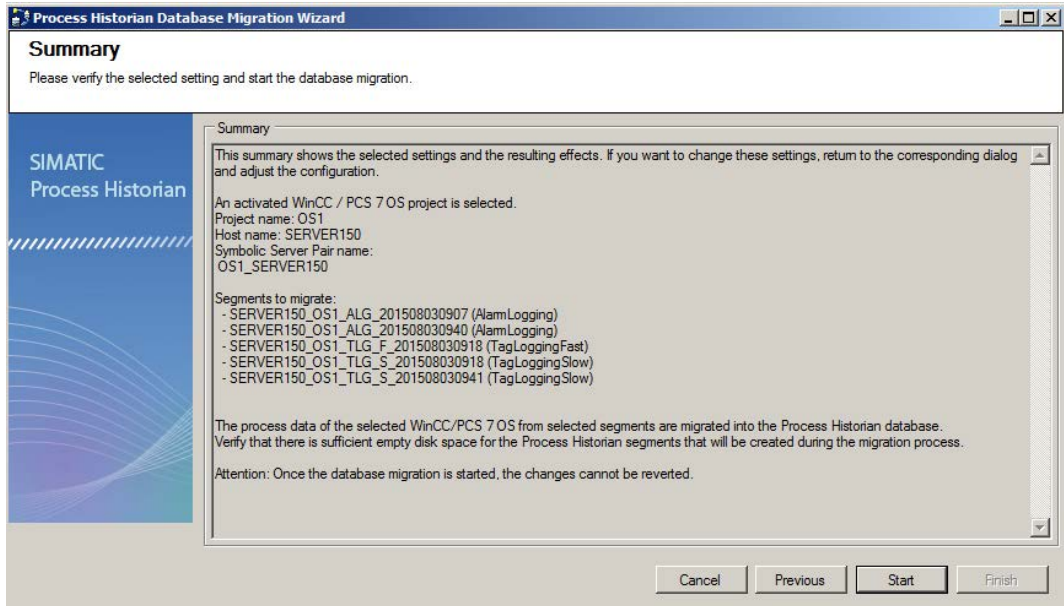

- 6. The migration progress is displayed.

When the migration is complete, stop the database migration wizard by clicking "Finish".

## Migration from segments that are older than the versions WinCC V7.0 SP3 or PCS7 V8.0

In the case of a migration from segments that are older than versions WinCC V7.0 SP3 or PCS7 V8.0, the backup segment does not contain all information required for the migration.

This information therefore has to be provided manually to the ProcessDataMigrator. The following two dialogs appear during the migration:

- Selection of a code page for reading out the message texts
- Selection of a WinCC configuration file with the Step7 text library

### Selection of a code page for reading out the message texts

This dialog is used to select a character set table in order that the stored message texts of alarms can be correctly read out and displayed.

The default setting "Western Europe (ISO)" can be used for all Western European languages and the American region.

A different character set table must be selected for the Asian region. To check whether the messages were correctly interpreted, use the "Preview with code page number".

### Selection of a WinCC configuration file with the Step7 text library

This dialog appears when the message texts in the segment contain format characters from the Step 7 text library. If the dialog appears during the migration, you have to select the WinCC configuration database that contains the table "CC\_Step7Text".

The two output fields are empty in the first segment in which a selection is required. You must specify the corresponding selection. The manual selection is applied in any further occurrence.

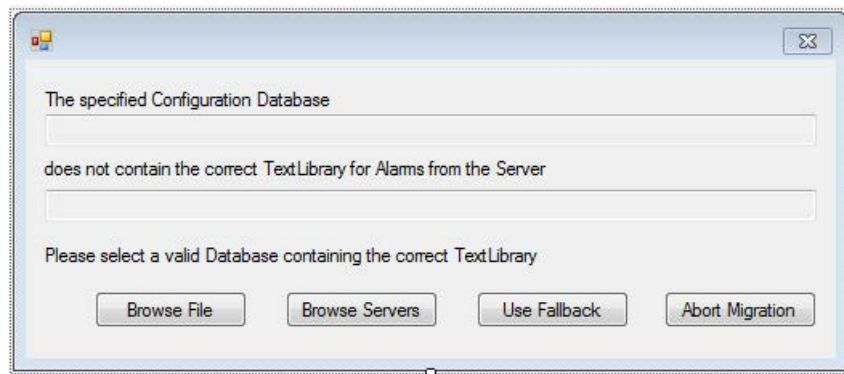

Use the "Browse File" and "Browse Servers" to select the WinCC configuration database.

During the selection of a file via "Browse File" you must select a database which is, e.g., located in a created project backup and not attached to an SQL server. You must select a database file of type "<...>.mdf".

If the segments originate from WinCC Runtime, you can select the OS server with the corresponding database under "Browse Servers". In this case the database has to be attached in the SQL server, which means that the project has to be open.

If the configuration file is no longer available, you have the option of importing the Step7 texts without resolution. This "fallback" means that the messages are saved with the appropriate format characters.

## Result

The selected data from the WinCC project online was migrated to the current Process Historian database.

### 3.7.2.4 WinCC project backup

#### Migrating WinCC project backup

1. Start the database migration wizard.
2. Select the source and the segment type.

In this case, backup segments of a PCS 7 project or WinCC project are migrated.

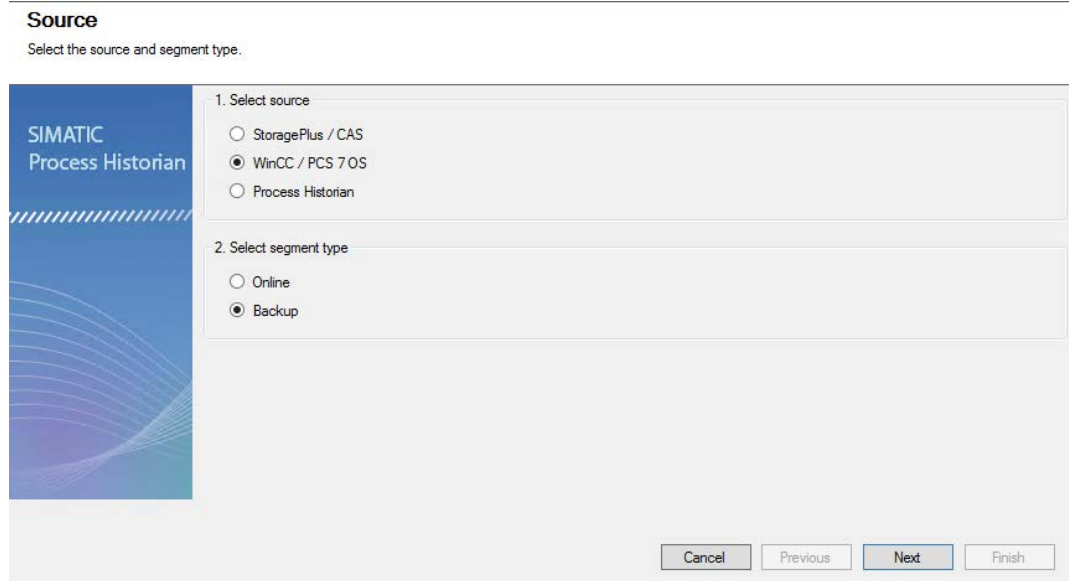

3. In the following dialog, select the "Add segments" or "Add folders" entry under "Add" in the shortcut menu of the displayed field. Use the shortcut menu to select and remove entries.

4. Select the desired segments.

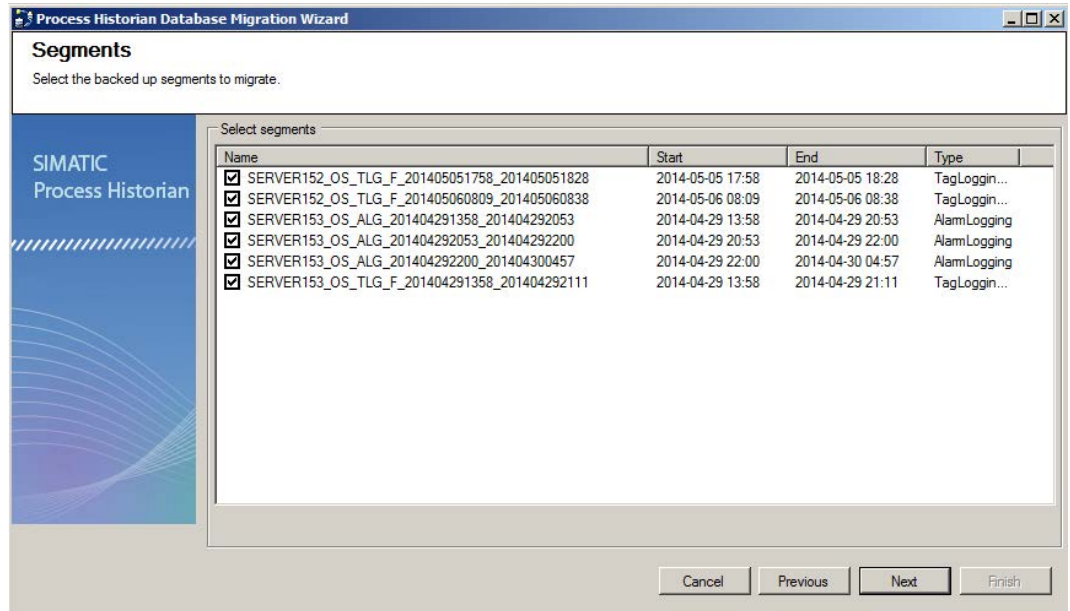

5. The database migration wizard indicates that the segment was found in the backups.

Click in the "Project in Process Historian" column to assign the storage location for the migrated project.

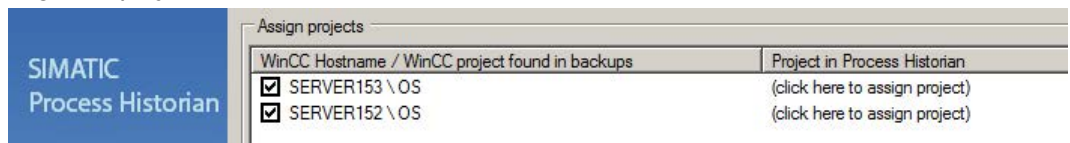

6. The plant structure opens.

Select the path in which you want to save the migrated project.

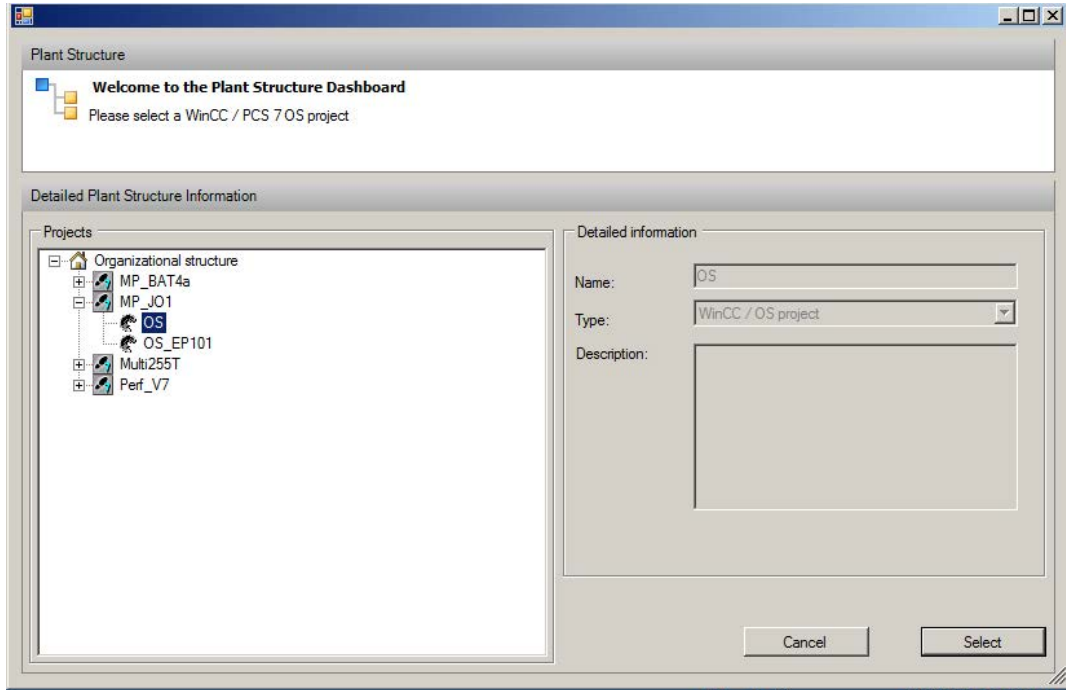

The selected path is displayed.

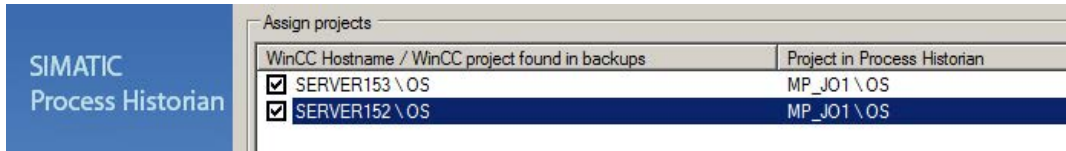



7. Check the displayed summary of the migration.

If the summary is correct, start the migration.

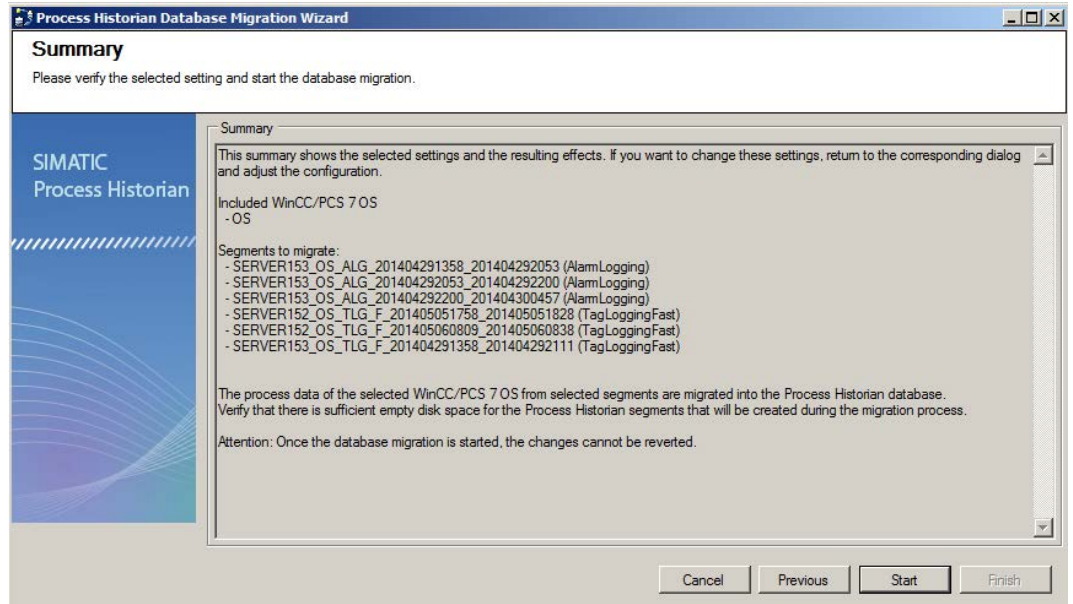

8. The migration progress is displayed.

When the migration is complete, stop the database migration wizard by clicking "Finish".

## Result

The selected data from the WinCC project backup was migrated to the current Process Historian database.

### 3.7.2.5 Process Historian project online

#### Introduction

The migration type "Process Historian / Online" is used in the following scenarios:

- Migration of a Process Historian project to another PC, for example, because the new hardware is more powerful. The migration is only possible in a recreated database that was never connected with the OS-Server.
- Migration of two independent Process Historian with different archiving sources that you want to combine.

Because the time settings for the segmentation, for example, can be changed during the switch to another PC, always use the migration function for the move.

This function is only available for databases that have been created with Process Historian 2014 or later.

#### Requirement

- You have created a Process Historian database on the target computer.
- You have configured the required database settings on the target computer, for example, the distribution of the database files on the hard drives available there.

#### Migrating Process Historian database

1. Close the process Process Historian in the Process Historian management console on the source PC with "Shut down".
2. Start the Database Migration Wizard on the target computer.
3. Select the source "Process Historian".

##### Source

Select the source and segment type.

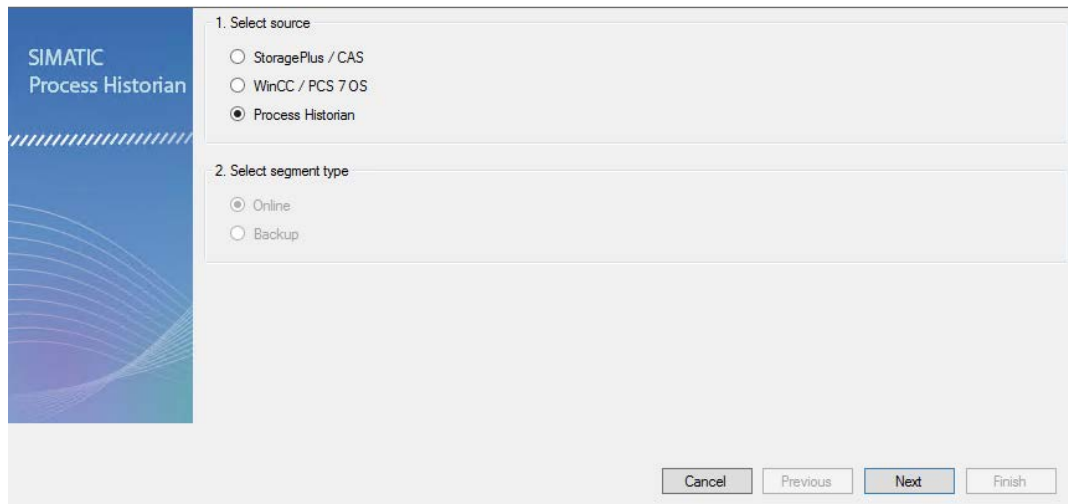

- The dialog for the source path shows the available SQL instances in the network.

Select the source PC in the selection list.

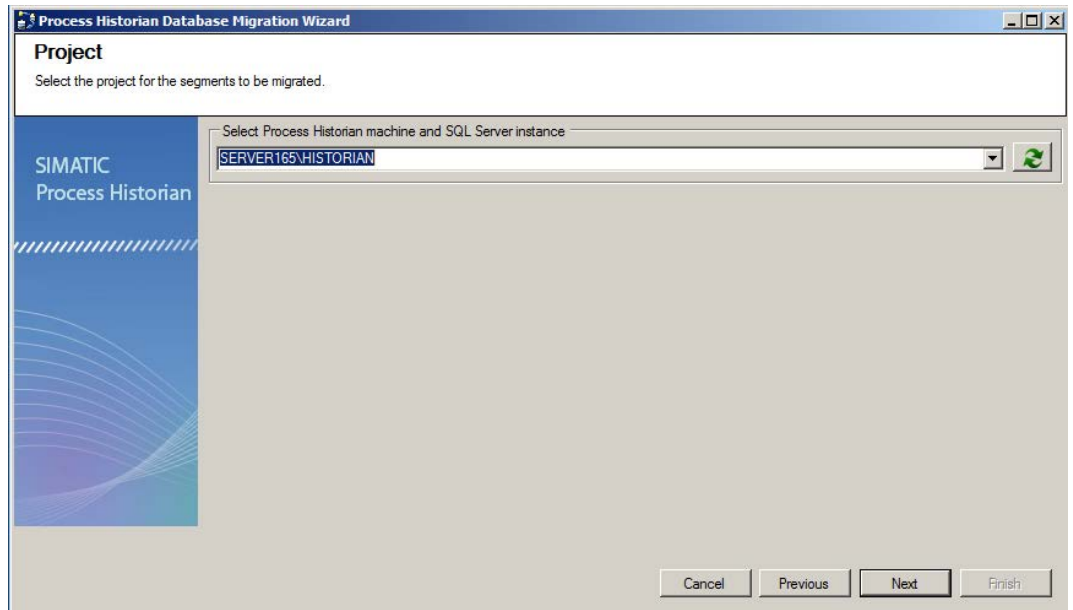

- Select the segments you want to migrate. Disable all other segments. Use the shortcut menu to select and remove entries.

Three data segments of the Tag Logging type and three data segments of the Alarm Logging type were selected in this example.

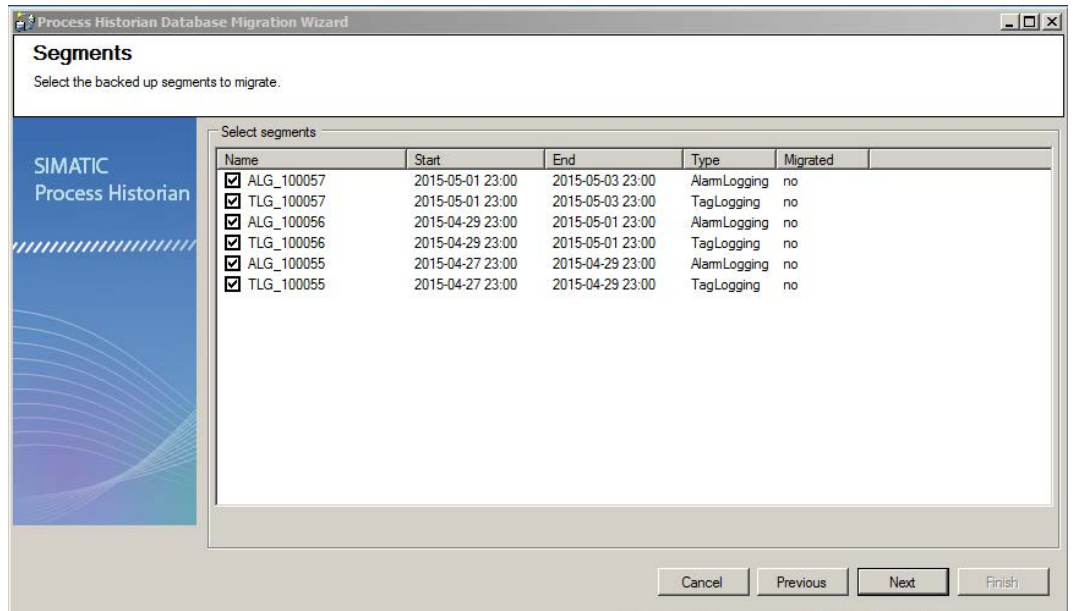

6. Check the displayed summary of the migration.

If the summary is correct, start the migration.

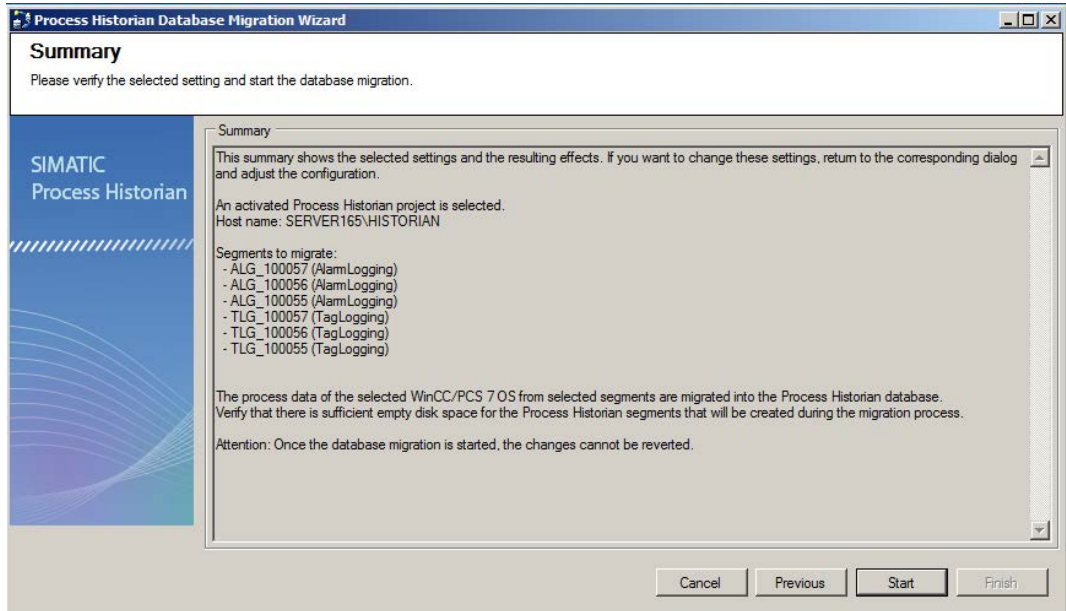

7. The migration progress is displayed.

When the migration is complete, stop the database migration wizard by clicking "Finish".

8. On the destination PC, activate the Process Historian and connect the PCS 7 OS and WinCC clients in the Process Historian system.
9. If you use Process Historian in the PCS 7 environment, perform the following additional steps:
  - Change the PC name of the Process Historian server in the PCS 7 project.
  - Download the project to all participating operator stations (OS), which means to all clients and servers on which Runtime is activated.

## Result

The selected data has been migrated from a Process Historian database to the destination PC.

## 3.8 Using a redundant system

### 3.8.1 Redundant system

#### Redundancy

The redundant systems are based on Microsoft SQL Server mirroring.

A redundant Process Historian system consists of symmetrically configured servers for master (principal) and standby (mirror) operation (e.g. PRIMERGY TX300 S6). We recommend a dedicated redundancy connection with a minimum bandwidth of 1 GB between the redundant Process Historian servers.

Process Historian requires a third system to monitor the availability of redundancy: the Witness. The Witness server component for scenarios with automatic redundancy failover is also installed on an additional server of the system, depending on the availability of an Information Server or WinCC server.

#### Short designations

The following designations are used for better legibility:

- **Principal:** Process Historian Master or PH Master
- **Mirror:** Process Historian Standby or PH Standby
- **Witness:** Information Server or WinCC Server with Witness component

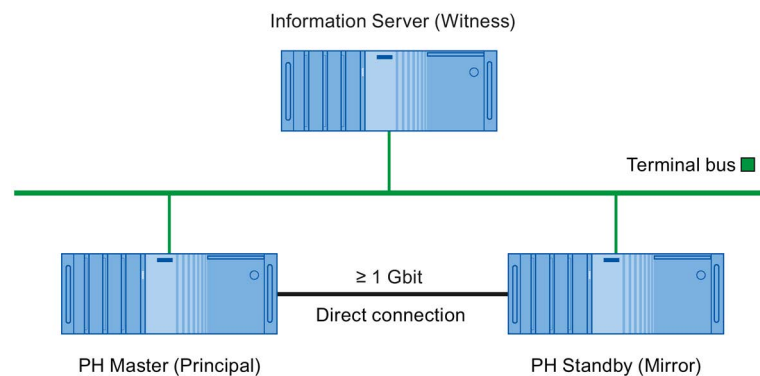

#### Setting up redundancy

You start the Redundancy Wizard for setting up redundancy with the "Redundancy" dashboard of the Process Historian Management Console.

You can use the "Redundancy" dashboard to check the status of the redundancy and remove the redundancy.

You can find additional information in the section 'Setting up Process Historian redundancy (Page 156)' as well as in the Process Historian Installation Notes.

### Write rights in the redundant system

Within a redundant system, only the Principal can write to the Process Historian .

Microsoft SQL Server continuously synchronizes the database of the Principal with the Mirror.

### Transaction log when a redundant partner fails

When the redundant Mirror fails, all data is stored in the transaction log of the Principal.

The data on the transaction log is synchronized as soon as the partner server is back online.

#### Size of the transaction log

Depending on the amount of incoming data and the downtime of redundant PC, the transaction log can grow quickly and become very large.

Following synchronization, the transaction log is reduced to its previous size.

If, for example, the Mirror goes down for an extended period of time, the lack of space can cause the Principal to switch to the "Locked" operating state. The Process Historian server is then locked and can no longer be set to "Enabled". The archive data of the OS are buffered in the cache. The period of caching depends on the space available and the volume of incurred data.

The redundancy synchronization (mirroring) must be switched off to prevent an overflow of the transaction log and locking of the Principal:

- Manual: You disable the redundancy synchronization in the "Redundancy" dashboard of the Process Historian Management Console.
- Automatic: The automatic shutdown function is activated in the "Redundancy" dashboard of the Management Console.
- The transaction log is automatically reduced.

You can find additional information on the "Locked" operating state in the section "Operating states of the Process Historian (Page 98)".

---

#### Note

##### Providing sufficient disk space

To avoid data loss due to a lack of space, ensure sufficient disk space:

- Regularly check the current disk space in the "I/O systems" dashboard (Page 119).
  - Determine which automatic mechanisms for reducing the used space can be activated in the "Compression" (Page 104) and "Backup/Restore" (Page 110) dashboards.
-

## 3.8.2 Redundancy scenarios

### Standard behavior of the redundant system

This section describes typical scenarios for a redundant Process Historian system.

Conflict resolution options through the "Redundancy" dashboard of the Process Historian Management Console are also described.

### Conflict management using the "Redundancy" dashboard

#### 1. Failover (switchover)

- In case of a switchover, the Principal and the Mirror swap roles.
- This switchover is only possible if the systems are synchronized.

#### 2. Disconnect (Disconnect)

- In case of a disconnect, the current Mirror is declared as 'Principal' even if the systems are not synchronized at this time.
- A disconnect results in the loss of data that is not synchronized.
- This is only possible on the Mirror.
- You should only use this if the Principal is in an undefined state or if the automatic failover fails.

#### 3. Remove (Remove)

- Mirroring ends when the redundancy is removed.
- This is only possible on the Principal.
- You should only use this if the Mirror does not respond or is not/will not be available for a long time.
- Stops the growth of the transaction log.

When disconnecting or removing, note that you must also change the settings on the clients so that the clients send no more data to the former mirror.

---

### Note

#### Redundancy switchover

When a redundancy switchover occurs, the database usually requires a few seconds to access the new Principal. Furthermore, the Process Historian Service must be activated again. Depending on the project size, activation can take several minutes. The data collected during this period is cached on the computers and immediately transferred to the Process Historian. The Process Historian Service remains in the "Active" state during this.

If there is no prompt to restart the systems, the restart cannot be performed manually because this would cause a loss of data.

---

## Scenario 1

### **The Mirror is temporarily inactive:**

1. The Principal and the Mirror are active and synchronized.
2. The Mirror is separated from the network, for example, for maintenance work.
3. There is no data synchronization between the Principal and the Mirror in this case.
4. The transaction log on the Principal is growing.
5. The Mirror is reactivated after a certain time period.
6. The Principal and the Mirror are in the resynchronization status.
7. Once the data is synchronized, the two server systems are once again synchronized and redundant.

## Scenario 2

### **The Principal fails:**

- The Principal and the Mirror are active and synchronized.
- Principal fails.
- The Mirror queries the Witness to determine if the Witness has an active connection to the Principal.
- If the Witness does not have a connection to the Principal, the Mirror automatically switches to 'Principal' mode.
- If the Witness has an active connection to the Principal, switchover is not performed automatically.
- The pending data from the transaction log is processed before the Mirror switches to Principal mode.

The operation can take some time.

- The connection to the Principal is re-established.
- The original Principal now takes on the role of the 'Mirror'.
- The Principal and the Mirror are in the resynchronization status.
- Once the data is synchronized, the two server systems are once again synchronized and redundant.



### Scenario 3

**The Witness fails:**

1. The Principal and the Mirror are active and synchronized.
2. The Witness fails.
3. A switchover is not necessary, because none of the archiving systems are affected.
4. An automatic switchover is not possible in this case.
5. The Witness is active once again.
6. Automatic switchover is possible once again.

### Scenario 4

**The Mirror is decommissioned and too little storage space is available for the transaction log.  
The Principal changes to the "Locked" state:**

1. The Principal and the Mirror are active and synchronized.
2. The Mirror is separated from the network, for example, for maintenance work.
3. Data synchronization between the Principal and the Mirror does not take place.
4. The transaction log on the Principal is growing.
5. The low limit for free storage space for the transaction log is violated:  
Less than 10% is free on hard disks with maximum 500 GB, or less than 50 GB is free on hard disks with more than 500 GB.
6. The Principal changes to the "Locked" state.  
The archive data of the OS are buffered in the cache. The cached time period depends on the available storage space and the accumulating volume of data.
7. The Mirror becomes active once again.
8. The Principal is unlocked and changes to "Active" state.
9. The Principal and the Mirror are in the resynchronization status.
10. The transaction log is automatically reduced after completion of the synchronization.
11. The archive data buffered on the OS in the cache is transferred to the Principal.

## Scenario 5

**The Mirror is decommissioned and too little storage space is available for the transaction log. The redundancy synchronization is deactivated to ensure operation of the Principal:**

1. The Principal and the Mirror are active and synchronized.
2. The Mirror is separated from the network, for example, for maintenance work.
3. Data synchronization between the Principal and the Mirror does not take place.
4. The transaction log on the Principal is growing.
5. Redundancy synchronization (Mirroring) is deactivated to prevent an overflow of the transaction log and a locking of the Principal.
  - Manual: You disable the redundancy synchronization in the "Redundancy" dashboard of the Process Historian Management Console.
  - Automatic: The automatic shutdown function is activated in the "Redundancy" dashboard of the Management Console.
6. The transaction log is automatically reduced.
7. The Principal is still available.
8. The Mirror becomes active once again.
9. No synchronization of the data takes place. The Mirroring needs to be set up again.

## Scenario 6

### The Mirror and the Principal are switched off and on in succession:

1. Both servers, Principal and Mirror, are synchronized.
2. The data is redundant and identical on both servers.
3. The Mirror is switched off.
4. The data is still saved on the Principal.

The data is no longer synchronized because the Mirror is switched off.

This means the database on both servers is not identical.

The transaction log of the Principal is growing.

5. The Principal is switched off.
6. No data can be saved.
7. The previous Mirror is switched on.
8. The Mirror works. However, the data of the Mirror cannot be synchronized with the Principal.

To prevent the risk of data loss, there is no automatic switchover from the Mirror for the Principal in this case.

### Result

- If you force a manual switchover, the previous Mirror takes over the role of the switched off Principal.
- If the original Principal is switched on once again, it takes over the role of 'Mirror'.

The previously saved data would be deleted in case of a synchronization with the new 'Principal' that is actually missing these databases.

These technical conflicts can be resolved in different ways with the Process Historian Management Console.

### 3.8.3 Setting up Process Historian redundancy

#### Setting up redundancy

1. To open the Management Console on the principal (master), select "Start > Programs > Siemens Automation > SIMATIC > Process Historian > Process Historian Management Console".
2. Select the 'Redundancy' dashboard in the Explorer.

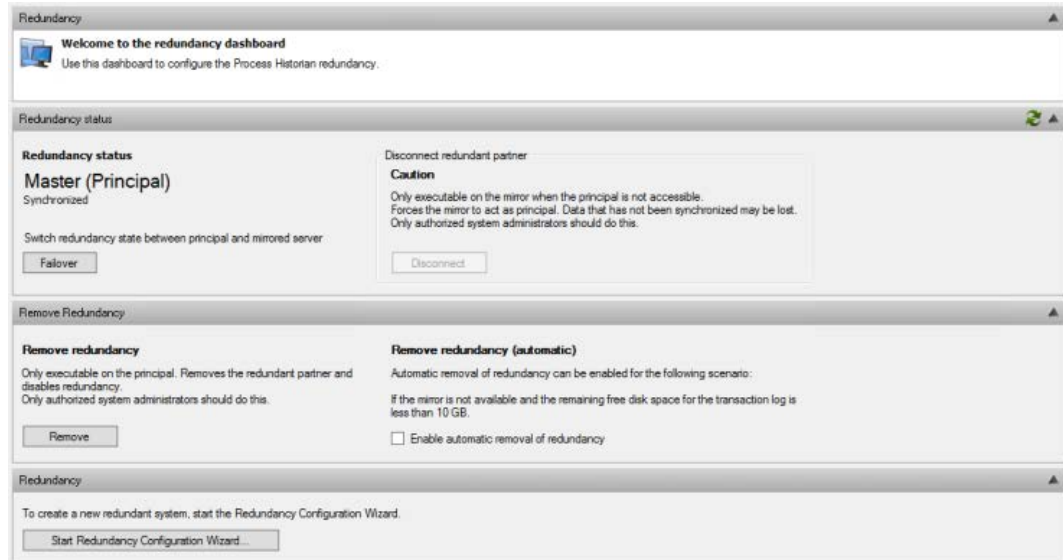

3. Click "Start Redundancy Configuration Wizard" in the 'Redundancy' area. You can configure the components "Principal", "Mirror" and "Witness" in the "Host Configuration" dialog.
4. Specify the network adapters that are used by the principal to perform the mirroring. To do this, select the dedicated redundancy link between the two Process Historian computers.
5. Configure the SQL server instance for each computer in the format "<Computer name>\<SQLServerInstanceName>".
6. Configuration for Principal:
  - The wizard is launched on the Principal, so this is the default instance. This setting cannot be changed.
  - The SQL Server instance for the server has the name "HISTORIAN".
  - Network adapter: Selection of a dedicated redundancy link.
7. Configuration with Mirror:
  - Select the SQL Server instance from the drop-down menu. If necessary, you can reload the list using the "Refresh" button.
  - Network adapter: Selection of a dedicated redundancy link.

8. Configuration for Witness:

- Select the SQL Server instance from the drop-down menu. If necessary, you can reload the list using the "Refresh" button. The instance depends on the base of the witness server, Information Server or WinCC. The instance is named "INFSERVER" or "WINCC" respectively. If the desired computer is not in the list or is displayed incomplete in the list with a host name but without an SQL instance, you can also enter the computer manually. Enter the "COMPUTER NAME\INSTANCE NAME" in the corresponding dialog box and move to the next field with the "Tab" key.
- Network adapter: Selection of the terminal bus link.

9. Click "Next".

10. Specify the ports and required firewall settings in the "TCP port settings" dialog. Accept the Process Historian defaults. The firewall settings specified in the setup are now taken into account.

---

**Note**

The default settings are edited if the proposed resources are already in use by a different application.

You can find more detailed information on the firewall settings in the section "Firewall settings".

---

11. A plausibility check of your configuration is performed in the 'Validation' dialog. This dialog is also used to validate the connectivity of the configured servers and paths. The action currently performed is indicated via a log in the "Validation" area.

- Click "Rerun" to restart the validation process if it has been interrupted .
- Confirm the successful validation with "Next".

12. The "Overview" dialog displays a summary of the completed settings.

- Verify these settings.
- Start the configuration process with "Next".
- Click "Previous" to correct any incorrect entries.

13. The prepared configuration of redundancy on the principal, mirror, and witness servers is executed in the "Execution" dialog.

- The new configuration is set up in a step-by-step process. The log of actions is displayed in the "Setup actions" area.
- Certain setup actions may take a longer time depending on the size of the Process Historian database.

We distinguish between the following processes:

- "Fast data backup and restore":  
This process generates a complete backup copy of the principal database and simultaneously restores it on the mirror.
- "Fast transmission of the transaction log":  
This process generates and synchronously restores a backup of the transaction log.

14. Click "Rerun" to restart a possibly interrupted configuration process.

### 3.8.4 Initial commissioning of redundant servers

#### Overview

When using redundant servers, the servers may not be started simultaneously during the first commissioning. First, you have to start the master server and then, a few minutes later, the standby server. If you start them at the same time, the Process Historian may not recognize the redundant system.

When redundant servers are used, only the master server sends the runtime data to the Process Historian. The standby server also builds a Message Queues to the Process Historian but it does not send runtime data.

After initial commissioning, the master server only sends data to the Process Historian when the "Store and Forward Cache" is synchronized. After first commissioning, the Master also sends data if the "Store And Forward Cache" is not synchronized.

If the master of a redundant WinCC server sends no data after the initial commissioning, you should check the "Store and Forward Cache" synchronization.

#### Procedure

1. Start the master server (Principal) and activate the project.
2. Make sure that the master server is activated.
3. Start the standby server (Mirror) and activate the project.

## Checking the master server

1. Determine the current master server. You can check the redundancy status, for example, in the WinCC tag management using the internal tag "@RM\_MASTER\_NAME".
2. Open the "PHSFSettings" file on the master server under "C:\ProgramData\Siemens\SFCache".
3. Determine the synchronization status. The following figure shows a synchronization status that is "OK".

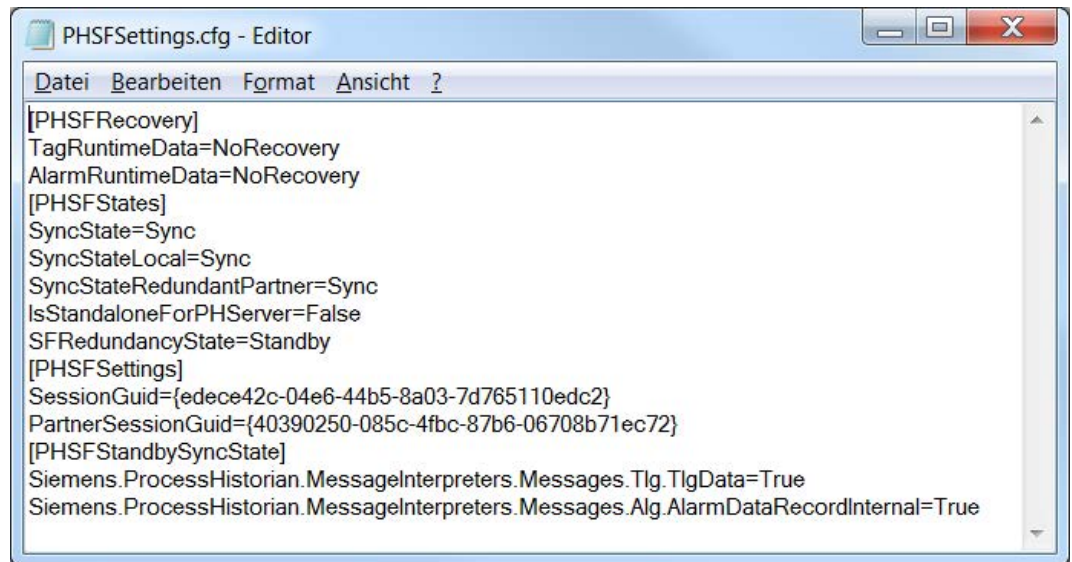

```
PHSFSettings.cfg - Editor
Datei Bearbeiten Format Ansicht ?
[PHSFRecovery]
TagRuntimeData=NoRecovery
AlarmRuntimeData=NoRecovery
[PHSFStates]
SyncState=Sync
SyncStateLocal=Sync
SyncStateRedundantPartner=Sync
IsStandaloneForPHServer=False
SFRedundancyState=Standby
[PHSFSettings]
SessionGuid={edece42c-04e6-44b5-8a03-7d765110edc2}
PartnerSessionGuid={40390250-085c-4fbc-87b6-06708b71ec72}
[PHSFStandbySyncState]
Siemens.ProcessHistorian.MessageInterpreters.Messages.Tlg.TlgData=True
Siemens.ProcessHistorian.MessageInterpreters.Messages.Alg.AlarmDataRecordInternal=True
```

4. If "WinCCSyncState = Error" occurs, the master does not send any data to the Process Historian after initial commissioning.

## 3.9 Using the Process Historian OPC UA server

### 3.9.1 PH OPC UA server - Overview

This section describes the OPC UA server for the Process Historian (PH-OPC-UA server). Basic knowledge of communication via OPC is required.

#### Overview

OPC and OPC UA denote standardized, vendor-independent interfaces and information models of the OPC Foundation.

OPC UA (Unified Architecture) is the successor technology of OPC, which was developed for reliable data exchange in automation engineering and other areas of applications. OPC UA has the following characteristics:

- Platform-independent
- Vendor-independent
- Use of standardized protocols as the communication medium (e.g. TCP, HTTP)
- Integrated security concept (authentication and authorization, encrypted communication and data integrity using signing)
- High-performance information model and provision of all data in a single address space (DA, HDA, A&C)



## OPC UA for Process Historian

Process Historian offers an integrated OPC UA server as an option.

The OPC UA server enables external OPC UA applications to communicate with the Process Historian server.

The external applications have read access to the following data of the local Process Historian server:

- Configuration data:
  - Project structure of the Process Historian server
  - Tag configuration and process values
  - Alarm system
- Archived data:
  - Tag archive
  - Message archive

The OPC UA server for the Process Historian supports the "OPC UA 1.02" specification of the OPC Foundation.

You can find detailed information about OPC UA specifications on the OPC Foundation website:

- <http://www.opcfoundation.org> (<http://www.opcfoundation.org>)

The PH-OPC UA information model is described in detail in the "OPC UA Information Model" document. This document is available on the Internet in English.

### 3.9.2 Installing the PH OPC UA server

#### How it works

The PH-OPC-UA server is installed as a Windows service.

The server is started automatically when you start the computer. However, you can only use the OPC UA server when the local Process Historian server is running.

#### Installation

##### Requirement

- The Process Historian is installed on the PC.
- The "Process Historian-OPC-UA server" license is available.

##### Procedure

1. Run the setup.
2. Carry out the installation.
3. Select under "Custom installation":
  - "Options" > "Process Historian OPC UA 2014 SP1" program package
4. To complete the installation, reboot the system.

#### Configuration

The PH OPC UA server is pre-configured during installation.

If required, you can change the server configuration using the OpcUaServerPH.xml configuration file. For additional information, refer to "How to configure the PH-OPC UA server (Page 176)".

You access the PH-OPC-UA server via the following URL:

- "opc.tcp://[HostName]:[Port]"

Parameter	Description
HostName	Placeholder for the computer name. Is used automatically
Port	TCP/IP port number The default is "4852".

The PH-OPC-UA server only supports the binary OPC UA protocol for communication (communication profile "UA-TCP UA-SC UA Binary"). The used port number is adjustable.

## **Discovery Server**

The OPC UA Local Discovery Server (LDS) of the OPC Foundation is installed along with the PH-OPC-UA server. The LDS allows OPC UA client applications to determine information about available OPC UA servers.

Depending on its configuration, the PH-OPC-UA server registers itself with zero, one or multiple Discovery servers. These servers can be installed either on the same PC or on another PC.

### 3.9.3 Security concept of OPC UA

The OPC UA security concept is based largely on:

- Authentication and authorization of applications and users involved
- Ensuring the integrity and confidentiality of messages exchanged between the applications

You can find technical details in the OPC UA specification, "Part 2".

#### Certificates

Certificates are the method used for authentication of the OPC UA applications. Each application has its own instance certificate with which it identifies itself in the public key infrastructure (PKI).

The certificates used by the PH-OPC-UA server are stored in the settings in the "OpcUaServerPH.xml" configuration file:

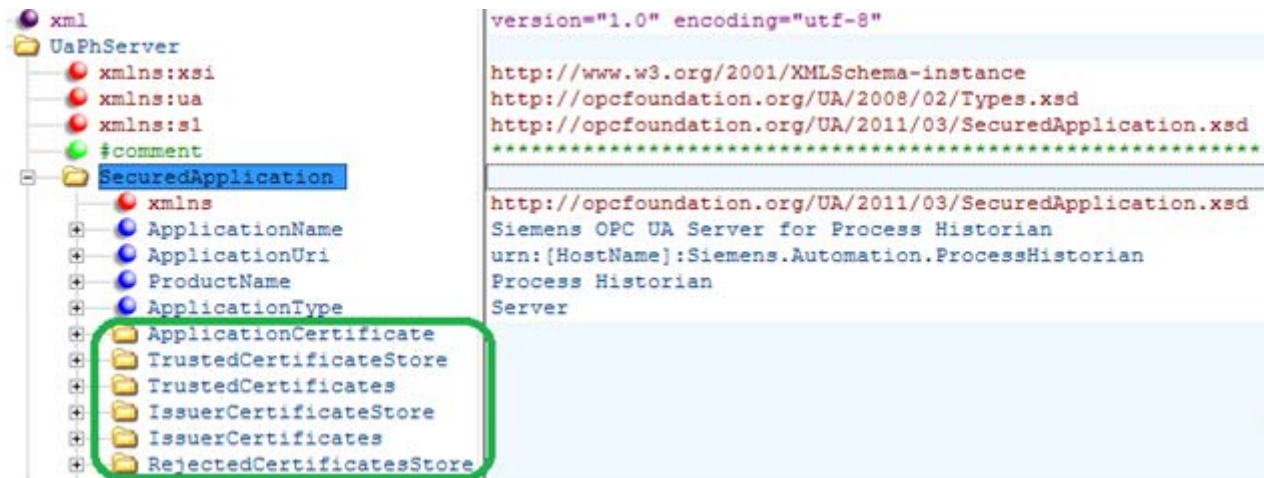

### Instance Certificate of PH-OPC-UA server

For secure operation, each PH-OPC-UA server requires its own instance certificate with a private key. The certificate is only valid on the corresponding computer and may only be used by the PH-OPC-UA server installed on that computer.

A self-signed certificate of the PH-OPC-UA server instance is created when the PH-OPC-UA server is installed. The instance certificate is stored both in the certificate folder of the PH-OPC-UA server as well as in the certificate store of the OPC UA Local Discovery Server.

The private key for the certificate is only stored in the certificate folder. You must restrict access to the folder with the private key to:

- The server itself
- The system administrator

<b>NOTICE</b>
<b>Access to the folder with the private key</b>
For security reasons, no other users or applications apart from the PH-OPC-UA server itself and the system administrator may have access to the private key of the PH-OPC-UA server.

The instance certificate generated upon installation and the corresponding private key can be replaced by the administrator of the system. In accordance with the applicable security concept for the system, the new instance certificate can be either self-signed or issued by a certification authority.

You specify the storage location for the instance certificate of the PH-OPC-UA server in the configuration file of the server. If necessary, the storage location can be changed by the system administration:

Parameter	Value	Meaning
StoreType	Directory	Type of certificate storage. The storage location must be "Directory".
StorePath	[ApplicationPath]\PKI\CA	The certificate and the private key are stored under this folder.

#### Example of instance certificate configuration



The instance certificate of the server in this case is in the directory "PKI\CA\Certs". The private key is in the directory "PKI\CA\Private".

### Trusted client certificates

The PH-OPC-UA server supports secure communication with trusted clients only. A client is trustworthy under the following conditions:

- The client has a valid self-signed certificate which is stored in the trusted certificates certificate memory of the PH-OPC-UA server
- The valid certificate of the client has been issued by a certification authority. The valid certificate from the certification authority must be located in the trusted certificates certificate memory of the PH-OPC-UA server.

In this case, only the certificate from the certification authority is required. The client instance certificate does not need to be located in the trusted certificates certificate memory.

You specify storage settings for trusted certificates using the PH-OPC-UA server configuration file:

Parameter	Meaning
StoreType	Type of certificate storage. The storage location can be either "Directory" or "Windows".
StorePath	The certificates of trusted clients are stored under this folder.

#### Example of configuration with "Directory" storage

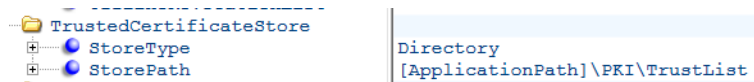

In this case, the PH-OPC-UA server trusts all clients whose instance certificates are located in the "PKI\TrustList\Certs" folder.

#### Example of configuration with "Windows" storage

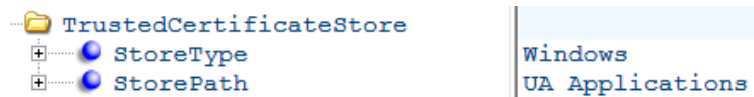

For this storage option, the instance certificates of the clients must be located in the certificate memory of the operating system under "<Local computer>\UA Applications".

### Certificates issued by a certification authority

Certificates from certification authorities that are required for verifying a client certificate chain are stored in the certificate memory of the certification authorities. You specify storage settings using the PH-OPC-UA server configuration file:

Parameter	Meaning
StoreType	Type of certificate storage. The storage location can be either "Directory" or "Windows".
StorePath	The certificates of trusted certification authorities are stored under this folder.

---

#### Note

##### Trustworthiness of CA certificates

Certificates from the memory of the certification authorities are not automatically trusted.

For a certification authority to be trusted, its certificate must be located in the memory for trusted certificates.

---

#### Example of configuration with "Directory" storage

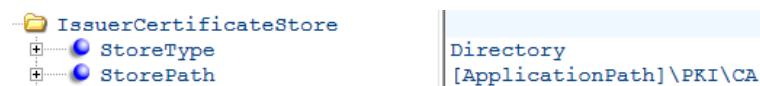

The certificates of trusted certification authorities are in this case located in the "PKI\CA\Certs" folder.

#### Example of configuration with "Windows" storage

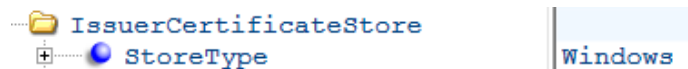

The "StorePath" parameter is not relevant. The certificates from certification authorities must be stored in the Windows certificate memory in accordance with the operating system requirements.

Certificates are trusted if they are located in one of these paths:

- <Local computer>\Trusted root certification authorities
- <Local computer>\Third-party root certification authorities

---

#### Note

##### CA certificates: Requirements

- The storage location for the server certificate must be "Directory".
  - The two storage locations for trusted client certificates and for certificates from certification authorities must have the same StoreType, i.e. both must either be "Directory" or "Windows".
-

### Client certificates not accepted

If a UA client accesses the PH-OPC-UA server whose certificate is not trusted, the PH-OPC-UA server rejects the secure communication. The PH-OPC-UA server copies the client's certificate into the folder for rejected certificates.

You specify storage settings for rejected certificates using the PH-OPC-UA server configuration file:



---

#### Note

Only the StoreType "Directory" is supported.

---

To enable secured communication with this client, you need to move the rejected certificate to the certificate memory for trusted certificates.



## 3.9.4 Configuring the security mechanisms

### Introduction

The following is ensured at the communication level:

- UA application authenticity
- The confidentiality of messages exchanged
- The integrity of messages exchanged

The security mechanisms used, for example algorithms for encrypting and signing, are set in standardized security policies. You can find technical details in the OPC UA specification under "Part 2", "Part 4" and "Part 7".

The security policies supported by the PH-OPC-UA server are set using the server configuration file in in "ServerConfiguration" and "SecuredApplication".



## SecuredApplication

In accordance with the OPC UA specification, the security mechanisms and explicitly enabled and disabled with the "SecurityProfileUris" element under "SecuredApplication".

The diagram below shows a SecuredApplication in which unsecured communication is disabled:

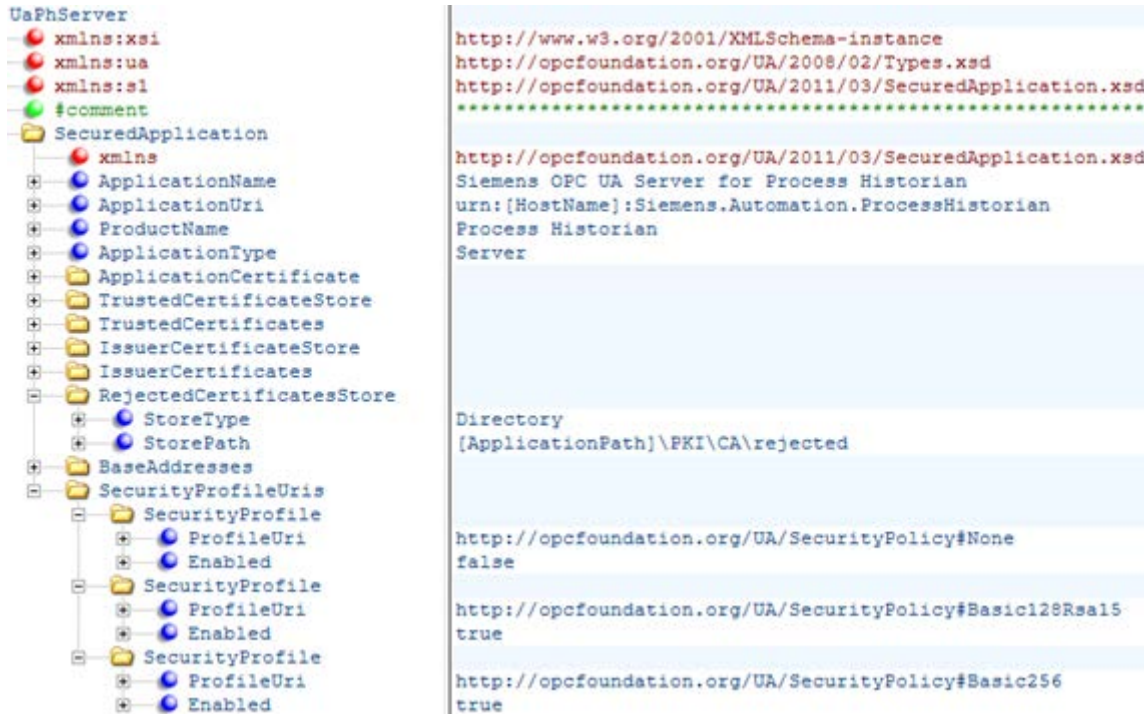

The PH-OPC-UA server thereby supports the two security strategies "Basic128Rsa15" and "Basic256" in runtime. "Message Security Modes Sign" and "SignAndEncrypt" are supported, but unsecured communication is not ("None"). When communication is established, the UA clients select the required Policy from this list.

### Note

#### Unsecured communication between client and server

Use the "None" setting only for test and diagnostics purposes.

For a secure communication between client and server, use at least the following settings during productive operation:

- SecurityPolicy: Basic 128Rsa15
- Message Security Mode: Sign

### User identity

In addition to the security mechanisms of the communication level, the PH-OPC-UA server also supports user authentication for the client applications using UserTokenPolicy "UserName". The client application must provide a valid combination of user name and password when communication is established. The PH-OPC-UA server verifies the combination in the user management of the operating system.

You specify the UserTokenPolicy using the configuration file of the PH-OPC-UA server:

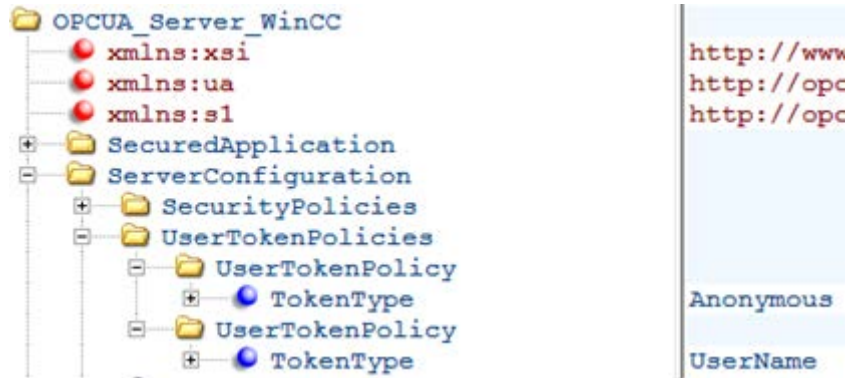

The PH-OPC-UA server uses this configuration to support both anonymous users and the Policy "UserName"..

### 3.9.5 Supported OPC UA services and profiles

#### OPC UA services

The following table sets out the functionality supported by OPC UA server 1.0.2:

OPC UA Service Sets	Services	Comment
Discovery Service Set	FindServers GetEndpoints	-
Secure Channel Session Service Set	All	-
View Service Set	Browse BrowseNext	Determination of the PH tags and objects
Attribute Service Set	Read HistoryRead	Example: <ul style="list-style-type: none"> <li>• Read property value</li> <li>• Read tag values or messages archived in the PH</li> </ul>
Subscription Service Set	CreateSubscription SetPublishingMode Publish RePublish DeleteSubscription	-
MonitoredItem Service Set	CreateMonitoredItems SetMonitoringMode DeleteMonitoredItems	Only for standard UA tags, e.g. Server/ServerStatus/State

### OPC UA profile and Conformance Units

The PH-OPC-UA server supports the following OPC UA profiles 1.02 without restrictions:

- 6.5.3 Base Server Behaviour Facet
- 6.5.14 A & C Base Condition Server Facet
- 6.5.30 Historical Raw Data Server Facet
- 6.5.107 UA-TCP UA-SC UA Binary
- 6.5.125 SecurityPolicy - Basic256
- 6.5.124 SecurityPolicy - Basic128Rsa15
- 6.5.123 SecurityPolicy - None

The PH-OPC-UA server supports the following OPC UA profiles shown in the following table, however with restrictions:

Profile	"Group"	Not supported "Conformance Unit"
6.5.8 Standard DataChangeSubscription Server Facet	Monitored Item Services	ModifyMonitoredItems DeadBand Filter Monitor MinQueueSize_02
6.5.9 Enhanced DataChange Subscription Server Facet	Monitored Item Services	Monitor MinQueueSize_05
6.5.47 Standard UA Server Profile	Attribute Services	Attribute Write StatusCode & Timestamp

### 3.9.6 Configuration file

The PH-OPC-UA server is configured using the "OpcUaServerPH.xml" configuration file.

This section describes the layout of the configuration file. The "How to configure the PH-OPC UA server (Page 176)" section describes how the PH-OPC-UA server is configured.

You can find the configuration file in the installation folder under the following path:

- \Siemens\ProcessHistorian\bin

<b>NOTICE</b>
<b>Changing the server configuration</b>
Changing the server configuration incorrectly can cause malfunctions and/or security vulnerabilities
The server configuration may only be performed by qualified personnel.

#### Section <Secured Application>

In this section, the OPC UA application security is set in compliance with OPC UA Specification / Part 6 / § "Security Settings Management".

<Secured Application>	
<BaseAddresses> <...></...> </BaseAddresses>.	Configuration of the URL for the OPC UA server.
<SecurityProfileUris> <SecurityProfile> <...></...> </SecurityProfile> ... </SecurityProfileUris>	Configuration of the supported security policies Use the "none" setting only for test and diagnostics purposes
<ApplicationCertificate> <TrustedCertificateStore> <TrustedCertificates> <...>	Revision of the default certificate configuration according to OPC UA Specification / Part 6. (optional)
</Secured Application>	

**Section <Server Configuration>**

In this section you can set further server-specific parameters.

<Server Configuration>	
<pre> &lt;SecurityPolicies&gt;   &lt;SecurityPolicy&gt;     &lt;...&gt;&lt;/...&gt;   &lt;/SecurityPolicy&gt;   ... &lt;/SecurityPolicies&gt; </pre>	<p>Configuration of the message security modes. Use the "none" setting only for test and diagnostics purposes</p>
<pre> &lt;UserTokenPolicies&gt;   &lt;UserTokenPolicy&gt;     &lt;...&gt;&lt;/...&gt;   &lt;/UserTokenPolicy&gt;   ... &lt;/UserTokenPolicies&gt; </pre>	<p>Configuration of user identification Use the "Anonymous" setting only for test and diagnostics purposes</p>
<Server Configuration	

**3.9.7 How to configure the PH-OPC UA server**

The PH-OPC-UA server is configured using the "OpcUaServerPH.xml" configuration file.

You can find the configuration file in the installation folder under the following path:

- \Siemens\ProcessHistorian\bin

You can find additional information on the configuration file under "Configuration file (Page 175)".

<p><b>NOTICE</b></p>
<p><b>Changing the server configuration</b> Changing the server configuration incorrectly can cause malfunctions and/or security vulnerabilities The server configuration may only be performed by qualified personnel.</p>

**Changing the port number of the OPC UA server**

If necessary, change the port number 4852 under <BaseAddresses>.

Do not use a port number that is already assigned to another application. Also observe the firewall settings (see "Firewall settings (Page 39)").

The parameter [HostName] is the placeholder for the computer name and is determined during runtime.

Example:

```
<BaseAddresses>
```



```
<ua:String>opc.tcp://[HostName]:5210</ua:String>
<BaseAddresses>
```

## Specifying security settings

You can find additional information on security settings under "Configuring the security mechanisms (Page 169)".

1. Make the security settings for communication.
2. Under `<SecurityProfileUris>`, you configure the supported "Security Policies".
  - Enable the setting with "true".
  - Disable the setting with "false".

Example:

```
<SecurityProfile>
  <ProfileUri>http://opcfoundation.org/UA/SecurityPolicy#None</ProfileUri>
  <Enabled>>false</Enabled>
</SecurityProfile>
```

3. Under `<SecurityPolicies>`, you configure the associated "Message security modes".  
To deactivate a setting, delete the entire entry `<SecurityPolicy>... </Security Policy>`.

Example:

```
<SecurityPolicy>
  <ProfileUri>http://opcfoundation.org/UA/SecurityPolicy#None</ProfileUri>
  <MessageSecurityModes>None</MessageSecurityModes>
</SecurityPolicy>
```

## Specifying user identification

You can find additional information on security settings under "Configuring the security mechanisms (Page 169)".

Specify the user identification for setting up the connection under `<UserTokenPolicies>`.

To deactivate a setting, delete the entire entry.

Example

```
<UserTokenPolicy>
  <TokenType>Anonymous</TokenType>
</UserTokenPolicy>
```

### 3.10 Aggregation

#### 3.10.1 Aggregation functionality

##### Aim of aggregation

Aggregation takes place to answer a query of process data within a reasonable time. The aggregates are permanently saved in the database. This reduces the number of raw data values that are required for an ad hoc query.

- The aggregation values are calculated and stored in the database close in time to the data archiving.
- Select the requested individual aggregate time interval in a way that ensures each possible query regarding query time interval and requested number of aggregates across the range. The requested number of individual values for processing is limited to the number that can be processed within the available query time of 60 seconds.
- Providing a sophisticated access function enables automatic selection of the correct aggregates and connection of the available pre-aggregate values so that the query can be processed as quickly as possible.

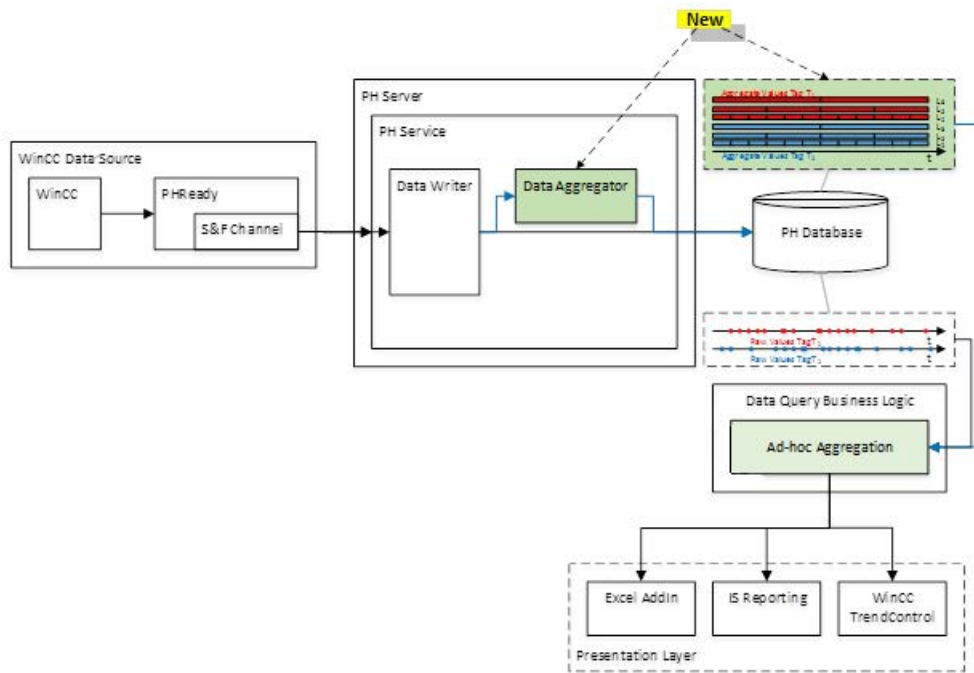

## Aggregate types

You can use the following aggregates for calculation in a time interval:

- MIN - minimum value
- MAX - maximum value
- AVG - arithmetic mean
- WAV - weighted average value
- SUM - sum of the values
- NUM - number of values
- INT - integral value

## Example of aggregates

The following aggregations are possible, for example:

- Query across all aggregate values of a specific tag within a time range  $T_Q = \{t_1 \dots t_2\}$ .
- Query across all aggregate values for all tags within a time range  $T_Q$ .
- Query of  $n$  aggregate values from a list of tags within a time range  $T_Q$ .

## Calculated processing time without pre-aggregated data

The typical number of  $T_Q$  is 2 years, sometimes 5 years for extended applications.

The typical value range is from 12 (monthly) to 300. 1200 is a typical number of values requested by WinCC TrendControl. In addition, limits can be requested depending on the queries and settings.

When such an average number of values is queried ad hoc, the volume of raw data that must be processed can become quite large.

$$T_Q = 2 \text{ y}, N = 2 \text{ values/s} * 60 \text{ s/m} * 24 \text{ h/d} * 365 \text{ d/y} * 2 \text{ y} = 126,144,000 \text{ values}$$

With a maximum number of values of 100,000 / sec that have to be processed, the required processing time per tag remains very high:

$$D_{Q(1)} = 126,144,000 \text{ values} / 100,000 \text{ values/sec} = 1,261.44 \text{ s} = 21.024 \text{ min}$$

The aggregate calculation is requested for 200 tags:

$$D_{Q(200)} = 200 * 21.024 \text{ min} / 60 = 70.08 \text{ h}$$

Hence, the assumed calculation rate of 100,000 values per second in the database would require a processing time of about 70 hours over a time period of 2 years for an aggregation query.

### Combinations of aggregate values

Aggregates can be combined or derived in order to, for example, map the time intervals "A" and "B" in one aggregate.

The basic aggregates "MIN", "MAX", "SUM", "NUM" and "INT" must be saved to calculate the aggregates that can be derived from them.

#### Aggregates that can be combined:

MIN:  $\text{MIN}(A) \times \text{MIN}(B) = \text{MIN}(A+B)$

MAX:  $\text{MAX}(A) \times \text{MAX}(B) = \text{MAX}(A+B)$

SUM:  $\text{SUM}(A) \times \text{SUM}(B) = \text{SUM}(A+B)$

INT:  $\text{INT}(A) \times \text{INT}(B) = \text{INT}(A+B)$

#### Aggregates that can be derived:

The aggregates "AVG" and "WAV" from the time intervals "A" and "B" can be derived from the basic aggregates.

#### AVG

$\text{AVG}(A) \times \text{AVG}(B) = \text{SUM}(A) + \text{SUM}(B) / \text{NUM}(A) + \text{NUM}(B)$

If the aggregate values SUM(A) and NUM(A) are known within the time range, the AVG values do not need to be explicitly saved as aggregate values in the database. The AVG values are derived aggregate values from the basic aggregates "SUM" and "NUM" of the basic values.

#### WAV

$\text{WAV}(A) \times \text{WAV}(B) = \text{INT}(A) + \text{INT}(B) / |A| + |B|$ . For example, "|A|" is the absolute value of "A" within the time interval of "A".

When the size of the aggregation time interval is known, the value "WAV(A)" can be calculated from the basic aggregate "INT(A)".

## 3.10.2 Calculation of the aggregates

### Calculation of the aggregates

This section describes how the values of the different aggregates from the raw data received are calculated automatically by Process Historian:

- The smallest necessary raw data sequence is to be stored in the work memory (work memory capacity).
- The lowest number of required calculation operations must be performed (CPU performance).
- The raw data is transferred in ascending chronological order for calculation of the aggregates.

The interpolation strategy to be applied must be defined for each tag.

An aggregation structure, which is managed in Runtime, is required for each tag and aggregation level.

### "MIN" aggregate

The "MIN" aggregate is defined as the smallest value within the raw data sequence of a time interval.

#### Calculation of "MIN"

If the time interval does not include any values, "MIN" is interpolated as follows.

The start value and the end value of the raw data sequence of the aggregation time interval is calculated. The smallest value is saved as temporary "MIN" value in the work memory. The processed raw data is discarded.

Each value that is transferred afterwards is compared to the "MIN" value from the work memory. If the new value is smaller than the "MIN" value, the new value is used as the "MIN" value.

If the transferred raw data value is outside of the aggregation time interval, the last temporary "MIN" value from the work memory is published as valid "MIN" value.

The raw data value that was transferred last is entered as first temporary "MIN" value in the next aggregation time interval.

#### Dimension

The dimension of the aggregates is the same as the dimension of the raw data.

#### Memory requirements

To implement the algorithm, 8 bytes per tag and aggregation level are required in the work memory in Runtime.

For 100,000 tags and 3 aggregation levels, the memory requirement is:  $100,000 \times 3 \times 8$  bytes = 2.4 MB.

## "MAX" aggregate

The "MAX" aggregate is defined as the largest value within the raw data sequence of a time interval.

### Calculation of "MAX"

The first transferred raw data value of the time interval is stored as temporary "MAX" value in the work memory. The processed raw data is discarded.

Each value that is transferred afterwards is compared to the "MAX" value from the work memory. If the new value is greater than the "MAX" value, the new value is used as the "MAX" value.

If the transferred raw data value is outside of the aggregation time interval, the last temporary "MAX" value from the work memory is published as valid "MAX" value.

The raw data value that was transferred last is entered as first temporary "MAX" value in the next aggregation time interval.

### Dimension

The dimension of the aggregates is the same as the dimension of the raw data.

### Memory requirements

To implement the algorithm, 8 bytes per tag and aggregation level are required in the work memory in Runtime.

For 100,000 tags and 3 aggregation levels, the memory requirement is:  $100,000 \times 3 \times 8$  bytes = 2.4 MB.

## "SUM" aggregate

The "SUM" aggregate is defined as the sum of all values within the raw data sequence of a time interval.

### Calculation of "SUM"

The first transferred raw data value of the time interval is stored as temporary sum value in the work memory. The processed raw data is discarded.

Each value that is transferred afterwards is added to the temporary sum value and the new sum value is stored in the work memory. The processed raw data is discarded.

If the transferred raw data value is outside the aggregation time interval, the last temporary "SUM" value from the work memory is published as valid "SUM" value.

The raw data value that was transferred last is entered as first temporary "SUM" value in the next aggregation time interval.

### Dimension

The dimension of the aggregates is the same as the dimension of the raw data.

### Memory requirements

To implement the algorithm, 8 bytes per tag and aggregation level are required in the work memory in Runtime.

For 100,000 tags and 3 aggregation levels, the memory requirement is:  $100,000 \times 3 \times 8$  bytes = 2.4 MB.

## "NUM" aggregate

The "NUM" aggregate is defined as the number of values within the raw data sequence of a time interval.

### Calculation of "NUM"

As soon as the first raw data value for an aggregation time interval is transferred, a temporary value with the number "1" is created and stored in the work memory. The processed raw data is discarded.

For each value that is transferred afterwards, the "NUM" value in the work memory is increased by "1" and stored in the work memory. The processed raw data is discarded.

If the transferred raw data value is outside of the aggregation time interval, the last temporary "NUM" value from the work memory is published as valid "NUM" value.

The raw data value that was transferred last is entered as first temporary "NUM" value in the next aggregation time interval.

When no values are transferred in an aggregation time interval, an assumed "NUM" value is specified at the interval limit before the next raw data values are transferred.

The "NUM" aggregates are set to "-1" for a "Sample and Hold" interpolation and to "-2" for a linear interpolation. This shows that the aggregates "MIN", "MAX" and "SUM" were calculated from virtual values. For "NUM" = "-1" or "-2", the "AVG" values and "WAV" values can be calculated correctly.

### Dimension

"NUM" aggregates have no dimension

### Memory requirements

To implement the algorithm, 8 bytes per tag and aggregation level are required in the work memory in Runtime.

For 100,000 tags and 3 aggregation levels, the memory requirement is:  $100,000 \times 3 \times 4$  bytes = 1.2 MB.



## "INT" aggregate

The "INT" aggregate is defined as the result of an integration across all values of a raw data sequence within a time interval.

The correct calculation of the aggregates depends on the interpretation of raw data.

### Calculation of "INT"

Unlike the other aggregates, "INT" cannot be calculated from a raw data sequence alone within an aggregation time interval. The calculation of an integral from a specified time range requires a continuous function within the time interval. This means an interpolation must be made based on available discrete points within the time interval before the integral value can be calculated.

Information regarding the last value of the low time interval range and the first value of the higher time interval range is required for this interpolation.

You can use the following methods for interpolation:

- Linear interpolation
- Sample and Hold interpolation
- Spline interpolation

### Memory requirements

To implement the algorithm, 8 bytes per tag and aggregation level are required in the work memory in Runtime.

For 100,000 tags and 3 aggregation levels, the memory requirement is:  $100,000 \times 3 \times 8$  bytes = 2.4 MB.

## "AVG" and "WAV" aggregates

"AVG" and "WAV" are calculated from the basic aggregates "NUM" and "SUM" or "INT".

### Memory requirements

Additional memory is not required for the aggregate in Runtime.

## 3.11 Process control messages

### Overview

Process Historian contains process control messages that visualize specific system states. These pre-defined messages only contain information about process control states and do not return process status data.

The table below provides an overview of the process control messages generated in Process Historian.

The following messages are generated by the SIMATIC service Process Historian Ready:

Message no.	Message text	Event
1012500	PHRDY: Start recovery for Process Historian	The transfer of missing data is started after restoration of the communication connection between WinCC and the Process Historian.
1012501	PHRDY: Recovery for Process Historian completed	The transfer of the data to the Process Historian is terminated.
1012502	PHRDY: No communication with Process Historian possible	The connection to the Process Historian cannot be established.
1012503	PHRDY: Communication with Process Historian is interrupted	Writing and/or reading of data to/from the Process Historian is not possible.
1012504	PHRDY: Communication with Process Historian restored	Writing and/or reading of data to/from the Process Historian is possible once again.
1012505	PHRDY: Process Historian Server offline since <Date Time>	The SIMATIC Process Historian service is not available. Read access to the data is possible.
1012506	PHRDY: Buffer limit Channel <Channel name> exceeded	The configured maximum available buffer memory of the selected communication channel (MSMQ) was exceeded. In this case, the Process Historian server can throttle the transfer of the data from the WinCC systems.
1012507	PHRDY: Buffer limit channel <Channel name> normal	The buffer memory is again operating within the configured limits.
1012508	PHRDY: Less than <number> GB of free storage space on the data carrier '<drive>' for communication with Process Historian.	The available storage space on the WinCC station has fallen below a specified limit.
1012509	PHRDY: Communication of Process Historian has been terminated. Less than <number> GB free memory on data carrier '<drive>'.	No more storage space available on the WinCC- station.
1012510	PHRDY: Connection to the Process Historian could not be established (check configuration).	Process Historian Ready is incorrectly configured (for example, service without user logon, configuration error in the configuration file, ...).

The following messages are generated by the Process Historian and sent to all clients:

Message no.	Message text	Event
1012600	PH: Data memory filled to <number %>	The warning limit of the data memory of the monitored drive was reached.
1012601	PH: System out of resources	The total load of all CPUs has been over 70% for at least 30s.
1012602	PH: Redundancy failed	Redundancy of the Process Historian server is no longer possible (because the redundancy was manually or automatically disconnected or the SQL server detected a problem etc.).
1012603	PH: Redundancy restored	The connection to the redundancy partner has been restored.
1012604	PH: Available licenses exceeded. Shutdown in <number> days	No adequate licenses available.
1012605	PH: PH-Ready <PC name> has failed	The Process Historian has lost the connection to the referenced PC.
1012606	PH: An automatic redundancy switchover of the Process Historian server has taken place.	An automatic redundancy switchover of the Process Historian server has taken place.
1012607	PH: Less than <number> GB of free storage space for the Process Historian database.	The warning limit of the memory for the Process Historian database was reached.
1012608	PH: Less than <number> GB of free storage space for the "tempdb" database.	The warning limit of the memory for the "tempdb" database was reached.
1012609	PH: Less than <number> GB of free storage space for the emergency restore operation.	The warning limit of the memory for the emergency restore operation was reached.
1012610	PH: New backup for the emergency restore operation failed. Too little storage space.	The creation of a complete backup failed.
1012611	PH: An unknown error occurred when creating backup for emergency restore operation.	The creation of a complete backup failed, unknown error.
1012612	PH: Storage path <path> not accessible for emergency restore operation.	The storage path for the database backup is not available.
1012613	PH: The emergency threshold for drive <path> was reached. Process Historian is therefore locked.	
1012614	PH: None of the prepared segments exist. Please check why this is.	
1012615	PH: Not all the prepared segments have been generated.	

## 3.12 Information about the operating state on the OS

### 3.12.1 Detailed information on the operating state

#### Overview

The variables "@PHServer\_Principal\_Details" and "@PHServer\_Mirror\_Details" store information in XML elements that is based on the current status and detailed information. The details are divided according to the affected components of the Process Historian:

- Process Historian Service
- Maintenance Service
- PH-Ready

The following example lists all XML elements that can potentially occur during operation of the Process Historian:

XML elements	Description
<code>&lt;State&gt;</code> <code>&lt;Name&gt;PhServer&lt;/Name&gt;</code> <code>&lt;Role&gt;Principal&lt;/Role&gt;</code> <code>&lt;Status&gt;Error&lt;/Status&gt;</code> <code>&lt;/State&gt;</code>	Contains the name of the Process Historian server that reported. Contains the server role: "Principal", "Mirror" or "Standalone". Contains the status of the server: "Error" if an error has occurred or "OK" if everything is good.
<code>&lt;Details&gt;</code> <code>&lt;ProcessHistorianService&gt;</code> <code>&lt;State&gt;Suspended&lt;/State&gt;</code> <code>&lt;/ProcessHistorianService&gt;</code>	Possible values for "State" are: <ul style="list-style-type: none"> <li>• "Suspended": Mirror has normal status. An error occurs after a switching over the mirroring for the Principal.</li> <li>• "Error": An unspecified error has occurred.</li> <li>• "Shutdown": The service was closed.</li> </ul>
<code>&lt;MaintenanceService&gt;</code> <code>&lt;State&gt;Activating&lt;/State&gt;</code>	Displayed if the connection to Discovery Service has been established and the configuration files have been read during activation of the Maintenance Services.
<code>&lt;MirroringRoleNotification&gt;MirroringSuspended</code> <code>&lt;/MirroringRoleNotification&gt;</code>	Shows the error conditions that can occur with mirroring: <ul style="list-style-type: none"> <li>• "SynchronizedPrincipalWithoutWitness": Principal cannot Witness be reached.</li> <li>• "SynchronizedMirrorWithoutWitness": Mirror cannot Witness be reached.</li> <li>• "ConnectionWithPrincipalLost": Principal cannot be reached.</li> <li>• "ConnectionWithMirrorLost": Mirror cannot be reached.</li> <li>• "MirroringSuspended": Mirroring has been suspended by the SQL Server due to problems that have occurred.</li> <li>• "NoQuorum": The mirrored system cannot make any decisions about a switchover.</li> <li>• "PrincipalRunningExposed": The Principal is running alone.</li> </ul>
<code>&lt;FreeDiskSpaceState EmergencyExceeded</code>	Not enough free disk space on the Process Historian .

XML elements	Description
LowDrives="E:\=>25GB G:\=>45GB" LowestFreeDiskSpacePercent ="9%" LowestFreeDiskSapceGb="4GB" </FreeDiskSpaceState>	The drives with insufficient free space. The smallest measured free disk space in percent. The smallest measured free hard disk space in GB.
<DatabaseStatus>Recovering</DatabaseStatus>	An database that has just been switched offline is not necessarily ready for accepting connections. The following values indicate possible reasons: <ul style="list-style-type: none"> <li>• Recovering</li> <li>• RecoveryPending</li> <li>• Suspect</li> <li>• Emergency</li> <li>• Offline</li> </ul>
<DatabaseBackup>IncompleteLessFreeDiskSpace	Error creating a database backup. Possible values are: <ul style="list-style-type: none"> <li>• "IncompleteLessFreeDiskSpace": Not enough free disk space on the backup drive.</li> <li>• "IncompleteUnspecifiedError": Errors that are not specified in more detail</li> <li>• "IncompleteWriteAccessDenied": No access rights to the backup drive.</li> </ul>
FreeDiskSpacePercent="4%" BackupPath="D:\Backups" CompletedPercent>="85%" LastBackupDate="2015.10.23 15:13:59"	The free disk space on the backup drive. The path of the backup drive. The implemented database backup in percent. Date of the last successful database backup for a file group.
<\DatabaseBackup> </MaintenanceService>	
<PHReady> <ErrorMessage>NoCommunication</ErrorMessage> </PHReady> </Details>	No communication to the Process Historian server.



# Index

"

"AVG" aggregate, 185  
"Backup/Restore" dashboard, 106, 109, 110, 123  
    New data, 70  
"Compression" dashboard, 104  
"Data sources" dashboard, 117  
"Database backup" dashboard, 111  
"Diagnostics" dashboard, 122  
"I/O Systems" dashboard, 119  
"INT" aggregate, 185  
"Licensing" dashboard, 121  
"Locked" state, 99, 105  
"MAX" aggregate, 182  
"MIN" aggregate, 181  
"NUM" aggregate, 184  
"Plant structure" dashboard, 115  
"Process Historian Management" dashboard, 100  
"Redundancy" dashboard, 151, 156  
"Segmentation" dashboard, 102  
"SIMATIC Batch Backup/Restore" dashboard, 123  
"SUM" aggregate, 183  
"WAV" aggregate, 185

.

.Net Framework  
    Installing, 17

@

@PHServer\_Mirror\_Details, 101, 188  
@PHServer\_Mirror\_State, 101  
@PHServer\_Principal\_Details, 101, 188  
@PHServer\_Principal\_State, 101

**A**

Aggregate types, 179  
Aggregates, 178, 181  
    Calculation, 181  
    Combination, 180  
    Example, 179  
Aggregation, 178  
Anchor point, 71

Archive segment, 106  
Autostart, 51  
AVG, 185

**B**

Backup file, 109  
Batch data, 123  
    Back up automatically, 126  
    Back up manually, 125  
    Backup, 124  
    Restoring, 128  
    Scheduler, 126  
Batch selection, 126

**C**

CAL segment, 70  
CAS project backup, 136  
CAS project online, 132  
CAU segment, 70  
Commissioning, 90  
Compressed archive segment, 69  
Compression, 104  
Configuration data, 91  
Customer support, (See support)

**D**

Dashboard  
    Overview, 95  
Data groups, 64  
Data source, 91  
Data sources, 100  
    Information, 117  
Database  
    Backup, 111  
    recovering, 93, 114  
    setting up, 79  
Database backup  
    Automatic, 112  
    Manual, 112  
    Path, 112  
    Redundant system, 114  
    Storage, 112  
    Storage medium, 113  
Database migration wizard, 131

Database Recovery, 93, 114  
Database segment, 65  
DatabaseInstallationWizard, 79  
    Standard mode, 79  
Delayed segments, 108  
Diagnostic message, 122  
Diagnostics, 122  
Disconnect, 151

## E

Event log, 122  
External archive segment, 69

## F

Failover, 151  
FAQ, (See support)  
Future segment, 71, 103  
Future segment, 71, 103  
Future segments, 68

## H

Hard drive load, 100

## I

Information server, 57  
Information Server  
    Plant, 59  
Initial commissioning  
    Redundant Systems, 158  
INT, 185  
Intermediate segment, 72

## L

Licenses, 121  
Licensing status, 101  
Lock, 117

## M

Management Console, 95  
Master, 149  
MAX, 182  
Memory requirements  
    Minimize, 120

Memory system, 119  
Merge, 116, 116  
Migrating CAS project, 132, 136  
Migrating CAS project, 132, 136  
Migrating Process Historian database, 146  
Migrating WinCC project, 139, 142  
Migrating WinCC project, 139, 142

## Migration

    CAS project backup, 136  
    CAS project online, 132  
    Overview, 129  
    Process Historian database, 146  
    System requirement, 131  
    WinCC project backup, 142  
    WinCC project online, 139

MIN, 181

Mirror, 149, 149, 156

## N

Non-compressed archive segment, 69  
NUM, 184

## O

Offline, 69  
    set, 110  
Offline (swapped out) archive segment, 69  
Online, 69  
Online segment, 66  
Online segments, 66  
Online support, (See support)  
OPC UA, 164  
    Certificates, 164  
    Security policy, 164  
Operating state, 100  
    Operator station, 101  
    XML detailed information, 188  
Operating states, 98  
    Overview, 98  
Operator station  
    Operating state, 101

## P

Partition, 64  
Past archive segments, 69  
PH-OPC-UA server, 160, 169, 172  
    Configuration file, 175  
    configuring, 175, 176  
    Installing, 162



- Overview, 160
- SecuredApplication, 171
- Security settings, 177
- ServerConfiguration, 170
- PH-Ready
  - Store and Forward Cache, 85
- Plant configurations, 59
- Plant structure, 116
- Principal, 149, 149, 156
- Process control messages, 186
- Process Data Migrator, 131
- Process Historian
  - Aggregates, 181
  - Commissioning, 90
  - Dashboards, 95
  - Data groups, 64
  - Diagnostics, 122
  - Indicators, 100
  - Licenses, 121
  - Locked, 99
  - Management Console, 95
  - Operating states, 99
  - Overview, 57
  - Plant, 59
  - Process control messages, 186
  - Recovering a database, 93
  - Redundancy, 149
  - Segmentation, 66, 102
  - Services, 58
  - Setting up the database, 79
  - Value sequence, 64
- Process Historian database, 146
- Process Historian Discovery Service, 58
- Process Historian Maintenance Service, 58
- Process Historian Redundancy Service, 58
- Process Historian server
  - Handle, 51
- Process Historian Server
  - Space requirements, 74
- Project information, 116
- Project tree, 115

## R

- Recovery, 114
- Redundancy, 149, 151
  - disconnect, 151
  - removing, 151
  - Scenarios, 151
  - setting up, 156
  - switching, 151

- Transaction log, 150
  - Write permissions, 150
- Redundancy status, 101, 159
- Redundancy switchover, 151
- Remove, 151
- Repository segments, 70
- Runtime segment, 71
- Runtime segments, 68
  - Total number, 103

## S

- Saved archive segment, 69
- Scheduler, 126
- Segment, 65
  - CAL segment, 70
  - CAU segment, 70
  - Colors, 68
  - Compressed archive segment, 69
  - External archive segment, 69
  - Non-compressed archive segment, 69
  - Offline, 69
  - Offline (swapped out) archive segment, 69
  - Online, 69
  - Past archive segment, 69
  - removing, 110
  - Saved archive segment, 69
  - Time range, 103
- Segment number, 65
- Segment types, 67
- Segmentation, 66
  - Anchor point, 72
  - change, 72
  - Configuration, 71
  - Default, 102
  - Example, 73
- Segments, 66
  - back up automatically, 108
  - back up manually, 107
  - Properties, 72
  - restoring, 109
  - Set "Offline", 108
  - uncompressed, 104
- ServiceMode, 51
- SIMATIC Batch, 123
- SIMATIC Batch server, 123
- SIMATIC Process Historian Server, 58
- Space requirements, 74
- Space requirements
  - Average, 74
- Space requirements
  - Process value, 74

Space requirements  
    Message, 74  
Space requirements for messages, 75  
Space requirements for process values, 75  
Standby, 149, 156  
Starting the redundancy configuration, 156  
Storage space, 105, 119  
    increase, 120  
Storage space monitoring, 120  
Store and Forward Cache, 85  
SUM, 183  
Support, 55

## T

Tag licenses, 121  
Technical support, (See support)  
Time range, 65, 71

## U

User identity, 172

## V

Value sequence, 64

## W

WAV, 185  
WinCC project backup, 142  
WinCC project online, 139  
WinCC Runtime, 92  
WinCC ServiceMode, 51  
WinCC single-user system, 59  
Witness, 61, 149  
Witness server, 157  
Work environment  
    Mixing domains and work groups, 51