

SIEMENS

SINAMICS

SINAMICS G120L

PM330L Power Modules

Hardware Installation Manual

Edition

01/2017

SIEMENS

SINAMICS

SINAMICS G120L Power Module PM330L

Hardware Installation Manual

<u>Basic safety instructions</u>	1
<u>Introduction</u>	2
<u>Installing/Mounting</u>	3
<u>Connecting</u>	4
<u>Service and maintenance</u>	5
<u>Technical specifications</u>	6
<u>Appendix</u>	A

Control version V4.7



01/2017

A5E35778999A AE

Legal information

Warning notice system

This manual contains notices you have to observe in order to ensure your personal safety, as well as to prevent damage to property. The notices referring to your personal safety are highlighted in the manual by a safety alert symbol, notices referring only to property damage have no safety alert symbol. These notices shown below are graded according to the degree of danger.

 DANGER
indicates that death or severe personal injury will result if proper precautions are not taken.
 WARNING
indicates that death or severe personal injury may result if proper precautions are not taken.
 CAUTION
indicates that minor personal injury can result if proper precautions are not taken.
NOTICE
indicates that property damage can result if proper precautions are not taken.

If more than one degree of danger is present, the warning notice representing the highest degree of danger will be used. A notice warning of injury to persons with a safety alert symbol may also include a warning relating to property damage.

Qualified Personnel

The product/system described in this documentation may be operated only by **personnel qualified** for the specific task in accordance with the relevant documentation, in particular its warning notices and safety instructions. Qualified personnel are those who, based on their training and experience, are capable of identifying risks and avoiding potential hazards when working with these products/systems.

Proper use of Siemens products

Note the following:

 WARNING
Siemens products may only be used for the applications described in the catalog and in the relevant technical documentation. If products and components from other manufacturers are used, these must be recommended or approved by Siemens. Proper transport, storage, installation, assembly, commissioning, operation and maintenance are required to ensure that the products operate safely and without any problems. The permissible ambient conditions must be complied with. The information in the relevant documentation must be observed.

Trademarks

All names identified by ® are registered trademarks of SIEMENS. The remaining trademarks in this publication may be trademarks whose use by third parties for their own purposes could violate the rights of the owner.

Disclaimer of Liability

We have reviewed the contents of this publication to ensure consistency with the hardware and software described. Since variance cannot be precluded entirely, we cannot guarantee full consistency. However, the information in this publication is reviewed regularly and any necessary corrections are included in subsequent editions.

Table of contents

1	Basic safety instructions	7
1.1	General safety instructions	7
1.2	Safety instructions for electromagnetic fields (EMF).....	11
1.3	Handling electrostatic sensitive devices (ESD).....	11
1.4	Industrial security	12
1.5	Residual risks of power drive systems	13
2	Introduction	15
3	Installing/Mounting	19
3.1	Installation condition	19
3.2	Power losses and air cooling requirements	20
3.3	Cabinet requirement	21
3.4	Unpacking and disposal.....	25
3.5	Mounting the Power Modules	27
3.5.1	Chassis units.....	32
3.6	Control Unit Installation	36
3.7	Cable routing of Control Unit and X9 terminals.....	41
4	Connecting up, switching on	43
4.1	Access to power and motor terminals	45
4.2	Line, motor and DC link connection	54
4.2.1	Protective conductor.....	54
4.2.2	Line connection	55
4.2.3	Length of motor cables	56
4.2.4	Motor connection.....	57
4.2.5	DC link connection for external Braking Module	57
4.3	Cable lugs	59
4.4	Open the connection to the basic interference suppression module for operation on IT system	60
4.5	Terminal X9.....	62
4.6	EMC compliant connection	64
4.6.1	Avoiding electromagnetic interference	64
4.6.2	EMC-compliant cabinet design	64
4.6.3	Cabinet design	65
4.6.4	Cabling.....	66
4.6.5	Equipotential bonding	68
4.7	Switching on.....	72
5	Service and maintenance	73
5.1	Maintenance	73

5.2	Forming.....	75
5.3	Replacing the cooling fan	77
6	Technical specifications	87
6.1	General technical data.....	87
6.2	Specific technical data.....	91
6.3	Derating data.	97
6.3.1	Derating factor of the output current as a function of the operating temperature	97
6.3.2	Derating as a function of the installation altitude	97
6.3.3	Derating factor of the output current as a function of the line voltage.....	99
6.3.4	Derating of the output current as a function of the pulse frequency	99
A.1	Further information on your converter	101
A.2	Electromagnetic compatibility	102
A.3	Abbreviations	106

Basic safety instructions

1.1 General safety instructions



DANGER

Danger to life due to live parts and other energy sources

Touching live parts can result in death or severe injury.

- Only work on electrical equipment if you are appropriately qualified.
- Always observe the country-specific safety rules for all work.

Generally, six steps apply when establishing safety:

1. Prepare for shutdown and notify all those who will be affected by the procedure.
2. Disconnect the machine from the supply.
 - Switch off the machine.
 - Wait until the discharge time specified on the warning labels has elapsed.
 - Check that it really is in a zero-voltage state, from phase conductor to phase conductor and phase conductor to protective conductor.
 - Check that every auxiliary circuit is de-energized.
 - Ensure that the motors cannot move.
3. Identify all other dangerous energy sources, e.g. compressed air, hydraulic systems, or water.
4. Isolate or neutralize all hazardous energy sources by closing switches, grounding or short-circuiting or closing valves, for example.
5. Take measures to prevent reconnection of the energy sources.
6. Ensure that the correct machine is completely interlocked.

After you have completed the work, restore the operational readiness by following the above steps in the reverse order.



WARNING

Danger to life through a hazardous voltage when connecting an unsuitable power supply

In the event of a fault, touching live parts can result in death or severe injury.

- Only use power supplies that provide SELV (Safety Extra Low Voltage) or PELV (Protective Extra Low Voltage) output voltages for all connections and terminals of the electronics modules.



! WARNING

Danger to life when live parts are touched on damaged devices

Improper handling of devices can cause damage.

For damaged devices, hazardous voltages can be present at the enclosure or at exposed components; if touched, this can result in death or severe injury.

- Ensure compliance with the limit values specified in the technical data during transport, storage and operation.
- Do not use any damaged devices.



! WARNING

Danger to life through electric shock due to unconnected cable shields

Hazardous touch voltages can occur through capacitive cross-coupling due to unconnected cable shields.

- As a minimum, connect cable shields and the cores of power cables that are not used at one end at the grounded housing potential.



! WARNING

Danger to life due to electric shock when not grounded

For missing or incorrectly implemented protective conductor connection for devices with protection class I, high voltages can be present at open, exposed parts, which when touched, can result in death or severe injury.

- Ground the device in compliance with the applicable regulations.



! WARNING

Danger to life due to electric shock when opening plug connections in operation

When opening plug connections in operation, arcs can result in severe injury or death.

- Only open plug connections when the equipment is in a no-voltage state, unless it has been explicitly stated that they can be opened in operation.

NOTICE

Material damage due to loose power connections

Insufficient tightening torques or vibrations can result in loose electrical connections. This can result in damage due to fire, device defects, or malfunctions.

- Tighten all power connections with the specified tightening torques, e.g. line connection, motor connection, DC link connections.
- Check all power connections at regular intervals. This applies in particular after transport.

 **WARNING****Danger to life due to fire spreading if housing is inadequate**

Fire and smoke development can cause severe personal injury or material damage.

- Install devices without a protective housing in a metal control cabinet (or protect the device by another equivalent measure) in such a way that contact with fire inside and outside the device is prevented.
- Ensure that smoke can only escape via controlled and monitored paths.

 **WARNING****Danger to life through unexpected movement of machines when using mobile wireless devices or mobile phones**

Using mobile radios or mobile phones with a transmit power > 1 W closer than approx. 2 m to the components may cause the devices to malfunction, influence the functional safety of machines therefore putting people at risk or causing material damage.

- When close to components, switch off all wireless devices and mobile phones.

 **WARNING****Danger to life due to the motor catching fire in the event of insulation overload**

There is a greater load on the motor insulation through a ground fault in an IT system. A possible result is the failure of the insulation with a risk for personnel through smoke development and fire.

- Use a monitoring device that signals an insulation fault.
- Correct the fault as quickly as possible so the motor insulation is not overloaded.

 **WARNING****Danger to life due to fire if overheating occurs because of insufficient ventilation clearances**

Inadequate ventilation clearances can cause overheating with a risk for personnel through smoke development and fire. This can also result in increased downtime and reduced service lives for devices/systems.

- Ensure compliance with the specified minimum clearance as ventilation clearance for the respective component. They can be found in the dimension drawings or in the "Product-specific safety instructions" at the start of the respective section.

 **WARNING**

Danger of an accident occurring due to missing or illegible warning labels

Missing or illegible warning labels can result in death or serious injury.

- Check the warning labels are complete based on the documentation.
- Attach any missing warning labels to the components, in the national language if necessary.
- Replace illegible warning labels.

NOTICE

Device damage caused by incorrect voltage/insulation tests

Incorrect voltage/insulation tests can damage the device.

- Before carrying out a voltage/insulation check of the system/machine, disconnect the devices as all converters and motors have been subject to a high voltage test by the manufacturer, and therefore it is not necessary to perform an additional test within the system/machine.

 **WARNING**

Danger to life due to inactive safety functions

Inactive or non-adapted safety functions can trigger machine malfunctions that can cause serious injury or death.

- Observe the information in the appropriate product documentation before commissioning.
- Carry out a safety inspection for functions relevant to safety on the entire system, including all safety-related components.
- Ensure that the safety functions used in your drives and automation tasks are adjusted and activated through appropriate parameterizing.
- Perform a function test.
- Only put your plant into productive operation once you have absolutely guaranteed that the functions relevant to safety are operating correctly.

1.2 Safety instructions for electromagnetic fields (EMF)



WARNING

Danger to life from electromagnetic fields

Electromagnetic fields (EMF) are generated by the operation of electrical power equipment such as transformers, converters or motors.

People with pacemakers or implants are at a special risk in the immediate vicinity of these devices/systems.

- Keep a distance of at least 2 m.

1.3 Handling electrostatic sensitive devices (ESD)

Electrostatic sensitive devices (ESDs) are individual components, integrated circuits, modules or devices that may be damaged by either electrostatic fields or electrostatic discharge.



NOTICE

Damage caused by electric fields or electrostatic discharge

Electric fields or electrostatic discharge can result in malfunctions as a result of damaged individual parts, integrated circuits, modules or devices.

- Only pack, store, transport and send electronic components, modules or devices in their original packaging or in other suitable materials, e.g. conductive foam rubber or aluminum foil.
- Only touch components, modules and devices if you are first grounded by applying one of the following measures:
 - Wearing an ESD wrist strap
 - Wearing ESD shoes or ESD grounding straps in ESD areas with conductive flooring
- Only place electronic components, modules or devices on conductive surfaces (table with ESD surface, conductive ESD foam, ESD packaging, ESD transport container).

1.4 Industrial security

Note

Industrial security

Siemens provides products and solutions with industrial security functions that support the secure operation of plants, solutions, machines, equipment and/or networks. They are important components in a holistic industrial security concept. With this in mind, Siemens products and solutions undergo continuous development. Siemens recommends that you inform yourself regularly about product updates.

For the secure operation of Siemens products and solutions, it is necessary to take suitable preventive action (e.g. cell protection concept) and integrate each component into a holistic, state-of-the-art industrial security concept. Any third-party products used must also be taken into account. For more information about industrial security, go to this address (<http://www.siemens.com/industrialsecurity>).

To stay informed about product updates as they occur, sign up for a product-specific newsletter. Go to this address (<http://support.industry.siemens.com/>) for more information.

WARNING

Danger as a result of unsafe operating states resulting from software manipulation

Software manipulation (e.g. by viruses, Trojan horses, malware, worms) can cause unsafe operating states to develop in your installation which can lead to death, severe injuries and/or material damage.

- Keep the software up to date.
You will find relevant information and newsletters at this address (<http://support.industry.siemens.com/>).
- Incorporate the automation and drive components into a state-of-the-art, integrated industrial security concept for the installation or machine.
You will find further information at this address (<http://www.siemens.com/industrialsecurity>).
- Make sure that you include all installed products into the integrated industrial security concept.

Note

Industrial security Configuration Manual

You can find a Configuration Manual on the topic of industrial security at this address (<https://support.industry.siemens.com/cs/ww/en/view/108862708>).

1.5 Residual risks of power drive systems

Residual risks of power drive systems

The control and drive components of a drive system are approved for industrial and commercial use in industrial line supplies. Their use in public line supplies requires a different configuration and/or additional measures.

These components may only be operated in closed housings or in higher-level control cabinets with protective covers that are closed, and when all of the protective devices are used.

These components may only be handled by qualified and trained technical personnel who are knowledgeable and observe all of the safety information and instructions on the components and in the associated technical user documentation.

When assessing the machine's risk in accordance with the respective local regulations (e.g., EC Machinery Directive), the machine manufacturer must take into account the following residual risks emanating from the control and drive components of a drive system:

1. Unintentional movements of driven machine components during commissioning, operation, maintenance, and repairs caused by, for example:
 - Hardware defects and/or software errors in the sensors, controllers, actuators, and connection technology
 - Response times of the controller and drive
 - Operating and/or ambient conditions not within the scope of the specification
 - Condensation/conductive contamination
 - Parameterization, programming, cabling, and installation errors
 - Use of radio devices/cellular phones in the immediate vicinity of the controller
 - External influences/damage
2. In the event of a fault, exceptionally high temperatures, including open fire, as well as emissions of light, noise, particles, gases, etc. can occur inside and outside the converter, e.g.:
 - Component malfunctions
 - Software errors
 - Operating and/or ambient conditions not within the scope of the specification
 - External influences/damage

Inverters of the Open Type/IP20 degree of protection must be installed in a metal control cabinet (or protected by another equivalent measure) such that the contact with fire inside and outside the inverter is not possible.

1.5 Residual risks of power drive systems

3. Hazardous shock voltages caused by, for example:
 - Component malfunctions
 - Influence of electrostatic charging
 - Induction of voltages in moving motors
 - Operating and/or ambient conditions not within the scope of the specification
 - Condensation/conductive contamination
 - External influences/damage
4. Electrical, magnetic and electromagnetic fields generated in operation that can pose a risk to people with a pacemaker, implants or metal replacement joints, etc. if they are too close.
5. Release of environmental pollutants or emissions as a result of improper operation of the system and/or failure to dispose of components safely and correctly

For more information about residual risks of the components in a drive system, see the relevant sections in the technical user documentation.

Introduction

Power Module - PM330L

PM330L Power Modules have been specifically optimized for driving pumps, fans, blowers and compressors with square-law load characteristic applications. The Power Module is available with the "internal air cooling" cooling method.

The Power Modules are available for following rated voltage and rated power:

- 3 AC 380 V ... 440 V: 280 kW ... 560 kW
- 3 AC 500 V ... 690 V: 280 kW ... 630 kW

The Power Modules can be connected to the following line supply systems:

- TN system
- TT system
- IT system

As standard, a line reactor ($uk \geq 2\%$) must be provided at the line input if $R_{sc} > 33$ (see the following diagram).

 WARNING
Danger to life through electric shock
Electric shock caused by incorrect TN/TT line system.
<ul style="list-style-type: none">• Operation on all TN/TT line systems ≤ 600 V permissible• Operation on TN/TT line systems > 600 V and grounded line conductor not permissible.

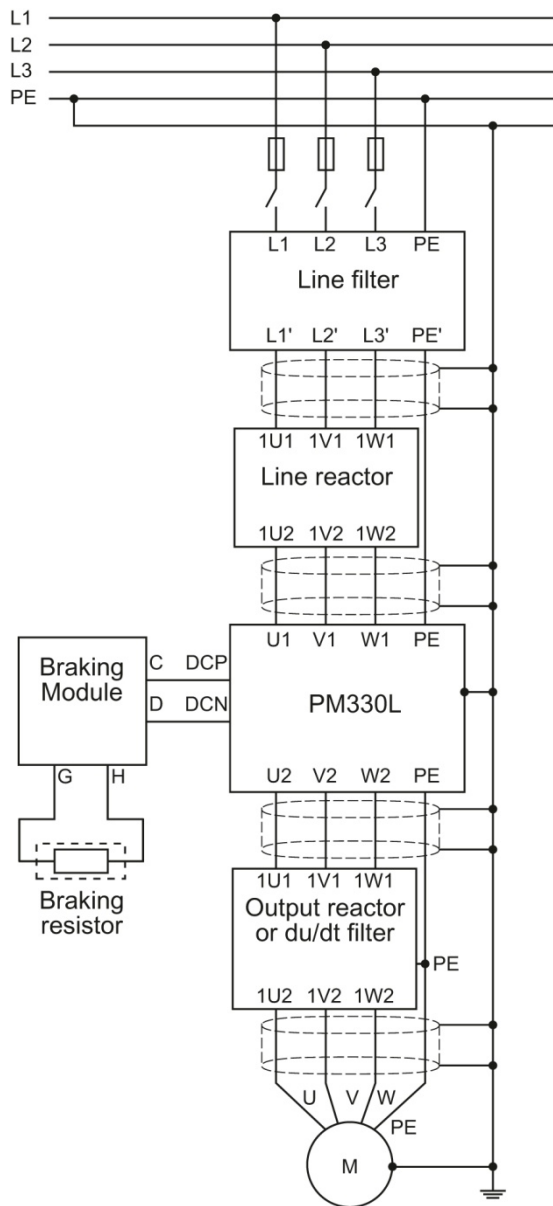

Figure 2-1 PM330L block diagram

Note**Principle of the precharging circuit**

SINAMICS PM330L Power Modules include a half-controlled thyristor bridge as rectifier circuit. As a result of the precharging principle with phase control, precharging is only started when all of the enable signals are available and by setting the ON/OFF command (p0840 = 1).

The DC link is then fully charged after approximately 4 s.

The Power Modules can be used with the following Control Units, including all communication versions with firmware version 4.7 or higher.

- CU230P-2 PN 6SL3243-0BB30-1FAx
- CU230P-2 DP 6SL3243-0BB30-1PAx
- CU230P-2 HVAC 6SL3243-0BB30-1HAx

Operation with Control Units other than those listed above is not permitted.

Installing/Mounting

3.1 Installation condition

General rules for protecting Power Modules against environmental effects

To ensure that the power module is installed in the correct environmental conditions, please ensure that you adhere to the following guidelines:

- The Power Modules are designed:
 - to be installed in an electrical cabinet
 - comply with degree of protection IP20 (frame size HX@380 V and HX/JX@690 V) and IP00 (frame size JX@380 V) according to IEC 60529
 - without protection against the ingress of water
- Furthermore, observe the following conditions:
 - Ensure that the device is free of dust and dirt.
(when using a vacuum cleaner, this must comply with ESD equipment rules)
 - Keep the unit away from water, solvents and chemicals
Take care to install it away from potential water hazards, for example, do not install it beneath pipes that are subject to condensation. Avoid installing it where excessive humidity and condensation may occur.
 - Keep it within the maximum and minimum operating temperatures. At temperatures > 40 °C and installation altitudes > 1000 m, the devices must be derated.
 - Ensure that the correct level of ventilation and air flow is provided.
 - Fast temperature changes of the air drawn in (e.g. by using cooling units) are not permitted due to the danger of condensation. Condensation is not permissible when switching on.
 - Ensure that all Power Modules and the cabinet are grounded according to the guidelines given in this chapter (see Chapter Connecting up, switching on (Page 43)).

It is only permissible that the Power Module is installed in a vertical position.

 WARNING
<p>Danger to life due to voltage</p> <p>To ensure safe operation of the equipment, it must be installed and commissioned by qualified personnel in full compliance with the warnings laid down in this manual.</p> <p>It is especially important to comply with general and local installation and safety regulations for working on plants and systems with hazardous voltages (e.g. IEC 61800-5-1) - as well as the relevant regulations regarding the correct use of tools and personal protective equipment (PPE).</p>

Protection against the spread of fire

The device may only be operated in closed housings or in control cabinets with protective covers that are closed, and when all of the protective devices are used. The installation of the device in a metal control cabinet or the protection with another equivalent measure must prevent the spread of fire and emissions outside the control cabinet.

Protection against condensation or electrically conductive pollution

Protect the device, e.g. by installing it in a control cabinet with degree of protection IP54 according to IEC 60529. Further measures may be necessary for particularly critical operating conditions.

If condensation or conductive pollution can be excluded at the installation site, a lower degree of control cabinet protection is permitted.

3.2 Power losses and air cooling requirements

General requirement

Installation in the cabinet and the cooling must guarantee that the air temperature - under all operating conditions and all possible cabinet equipment configurations - inside the Power Module at the top in the area of the rectifier modules is a maximum of 65 °C - and the air intake below the Control Unit (behind the left hand housing flap) is a maximum of 60 °C.

Cooling requirement

Depending on the power losses of the various components a specific cooling air flow is required to protect the components from overheating. The following equation shows you how to calculate the required air flow.

1. Add the power losses of the individual components.
2. Calculate the air flow required, using the formula.

$$\text{Air flow [l/s]} = \frac{\text{Power loss [W]}}{\Delta T \text{ [K]}} * 0.86$$

ΔT : allowable temperature rise in the cabinet

3. Ensure that no equipment is mounted that has a negative influence on the cooling air flow.
4. Ensure that the cooling vents in the Power Module are free of any obstructions to allow the air to flow freely.
5. Avoid short circuits of the cooling air using partitions, if necessary.
6. Provide an adequate cabinet with sufficient ventilation and suitable air filters.

The power losses and the required air flow of the Power Modules are provided in Chapter Specific technical data (Page 91).

The values are valid for:

- Rated output current
- 50 Hz output frequency
- 2 kHz pulse frequency

3.3 Cabinet requirement

The electrical cabinet installation must be realized in accordance with the dimension drawings supplied. The minimum electrical cabinet size for installation of PM330L power modules can be referred in following:

- For HX, cabinet size: 800 mm x 2000 mm x 600 mm (width x height x depth)
- For JX, cabinet size :1000 mm x 2000 mm x 600 mm (width x height x depth)

Before power module installation, at least two support plates should be installed to the cabinet frame according to following three steps:

- 1) Remove the side & back & top plate of electrical cabinet, see Figure 3-1;
- 2) Mounting support plate, see Figure 3-2;
- 3) Finish mounting support plate, see Figure 3-3;

3.3 Cabinet requirement

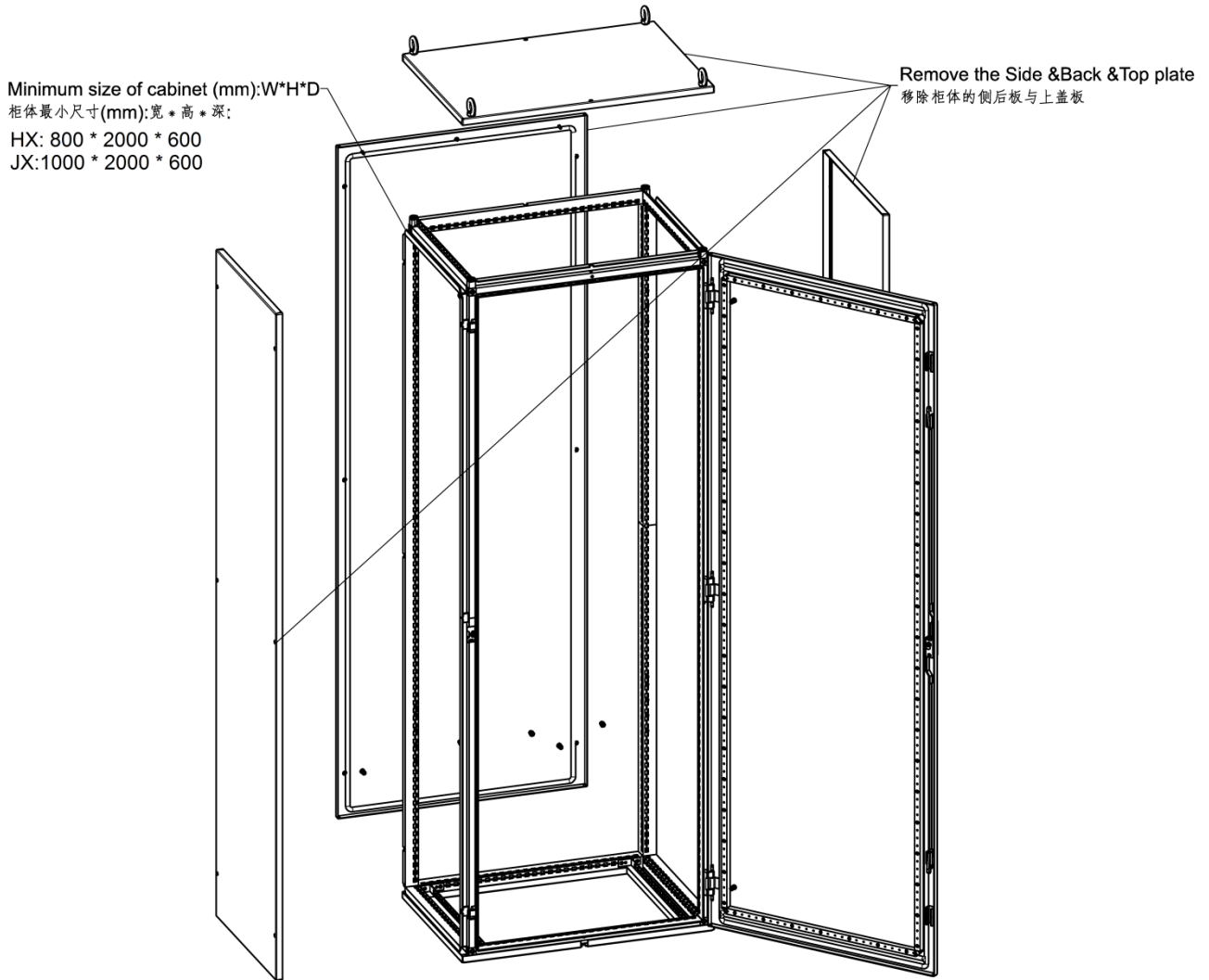

Figure 3-1 Remove the frame plates of electrical cabinet

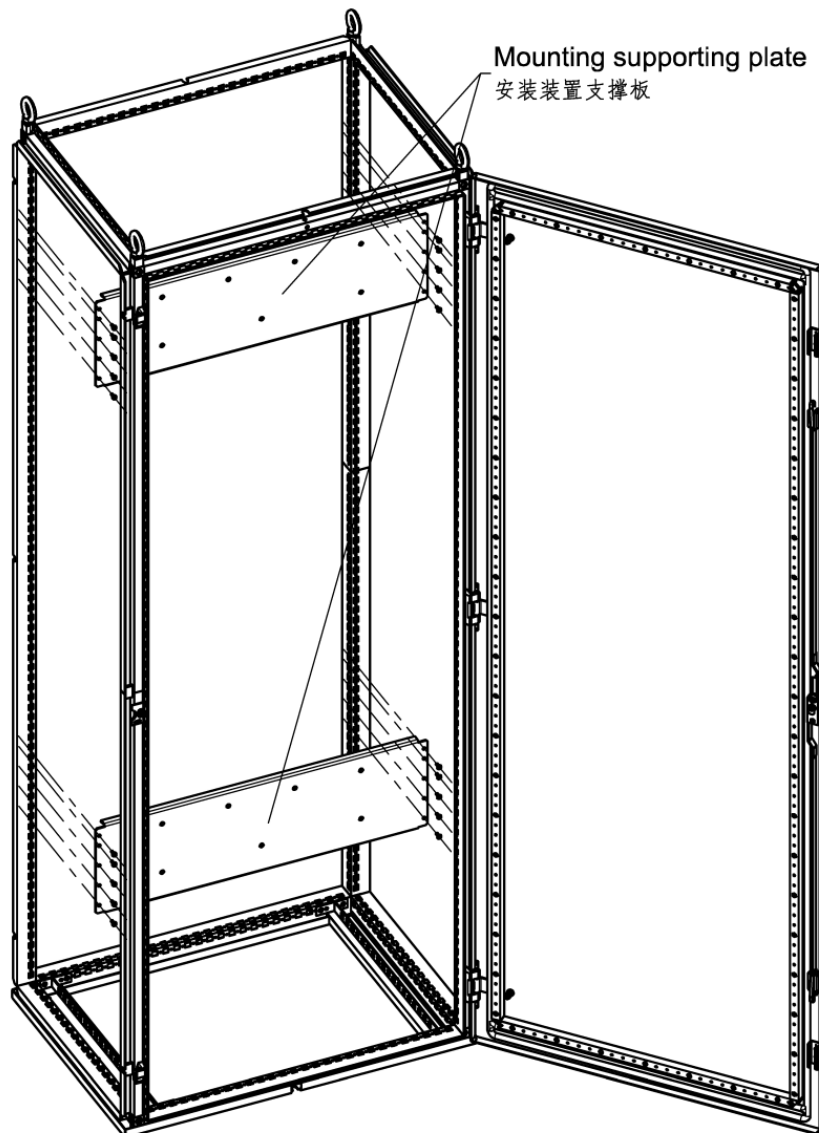

Figure 3-2 Mounting supporting plate

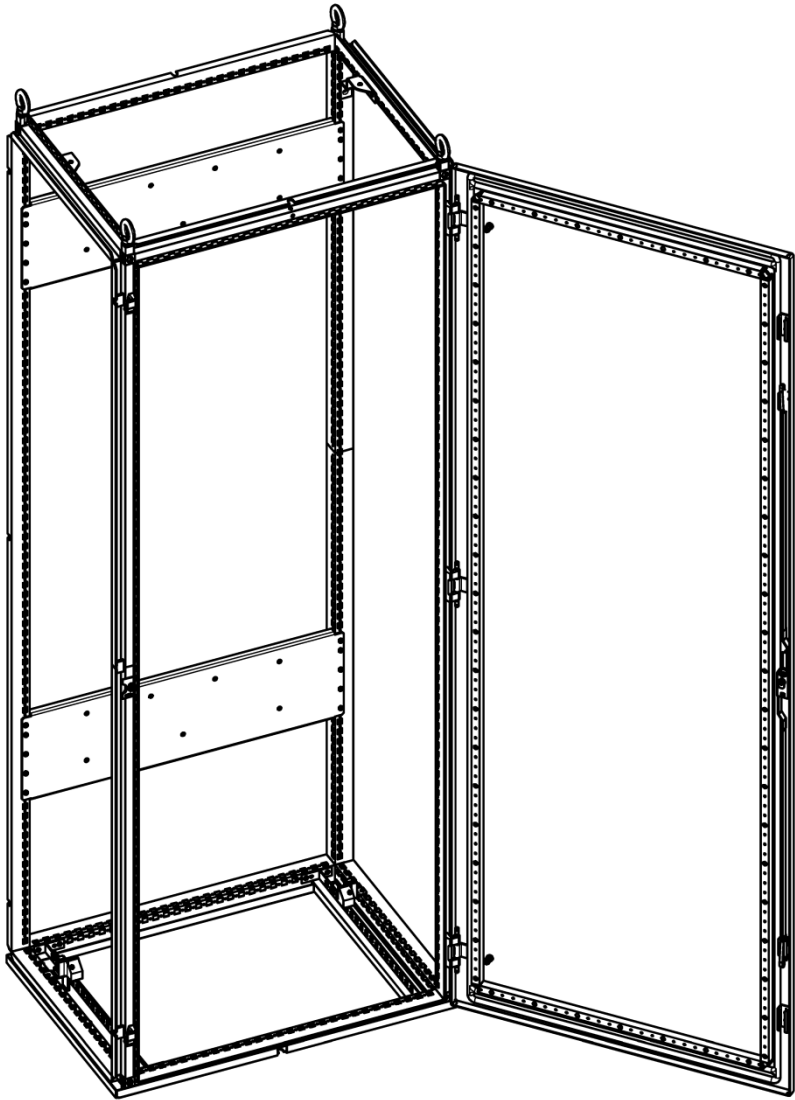

Figure 3-3 Finish mounting supporting plate

3.4 Unpacking and disposal

Remove the package

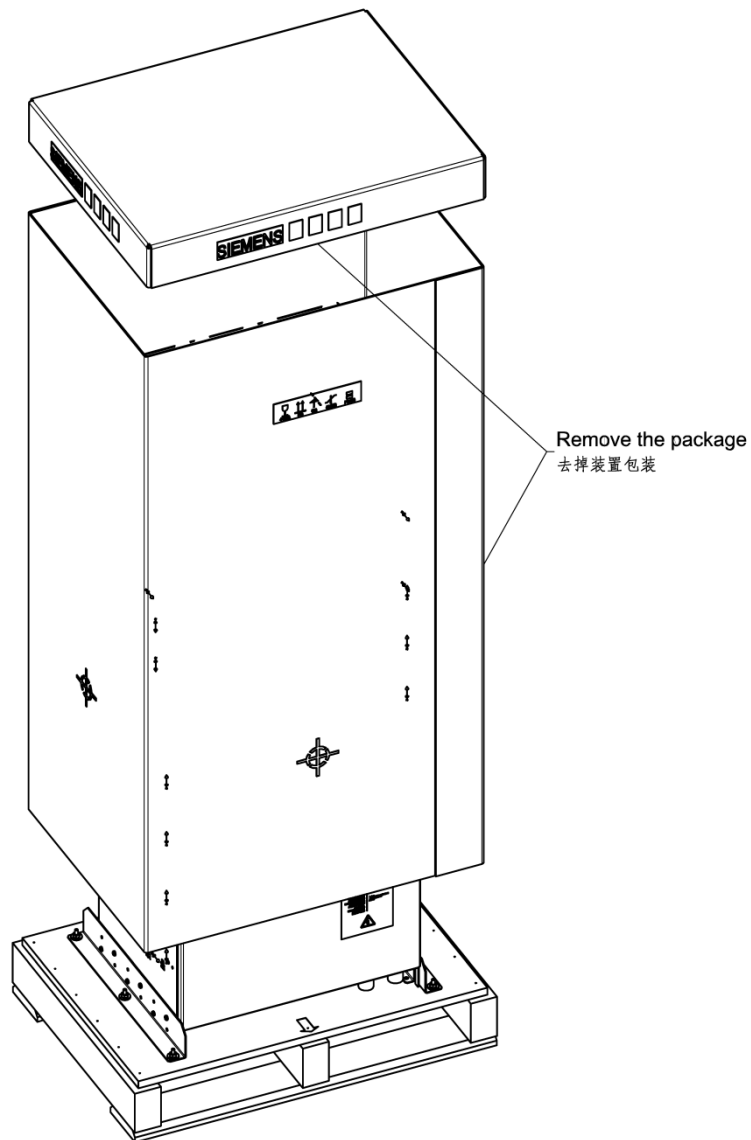

Figure 3-4 Unpacking

Remove the pallet

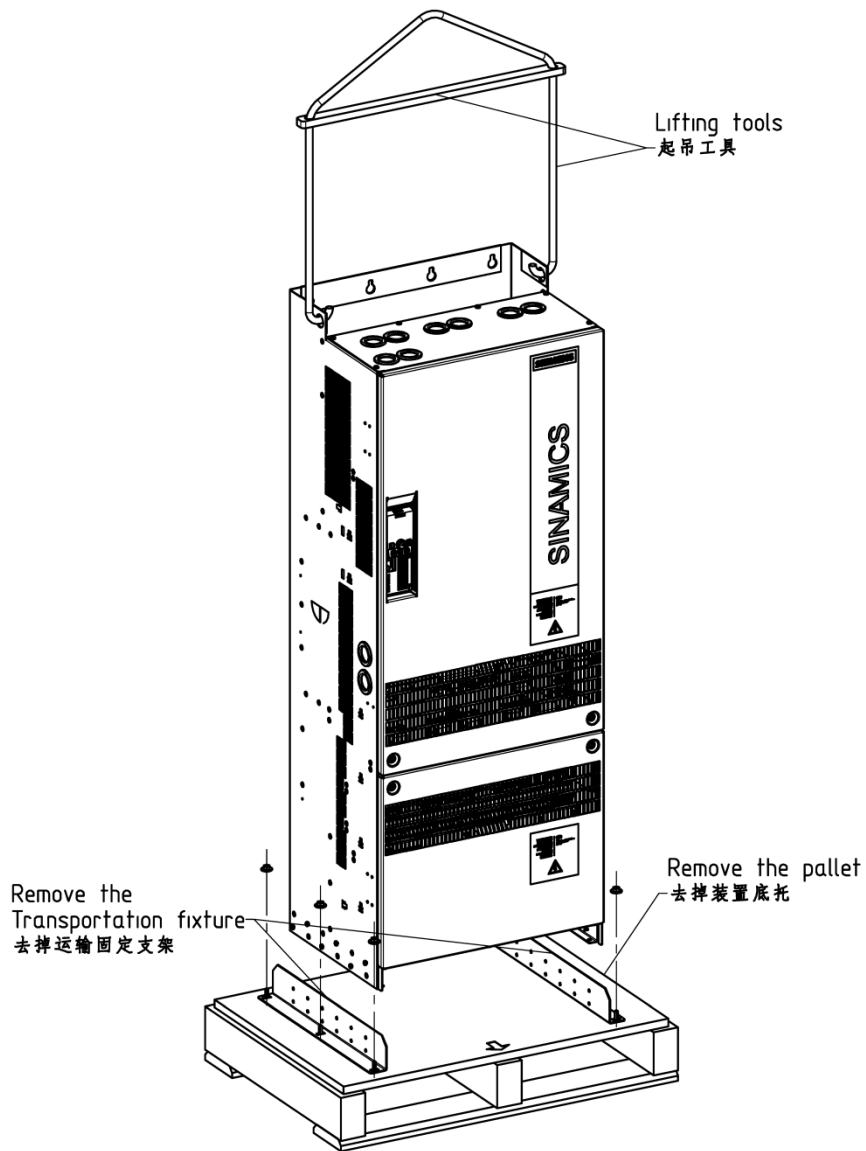

Figure 3-5 Example of remove the pallet (Frame size HX@380 V)

Note

The converter packaging can be reused. Store the packaging carefully for re-use.

The individual components of the packaging can be recycled or disposed of in compliance with local regulations.

3.5 Mounting the Power Modules



WARNING

Danger to life if the fundamental safety instructions and remaining risks are not carefully observed

The non-observance of the fundamental safety instructions and residual risks stated in Chapter Basic safety instructions (Page 7) can result in accidents with severe injuries or death.

- Adhere to the fundamental safety instructions.
- When assessing the risk, take into account residual risks.

The Power Modules are designed to be mounted in a cabinet using screws, nuts and washers accordance with the dimension drawings.

Note

EMC

- To comply with EMC specifications, it is recommended to mount the converter on an electrically conductive mounting panel in the cabinet. This mounting panel should be connected to the cabinet PE.

Note

Fixing elements used

The following fixing elements are used:

- M8 screw
- Washer according to DIN EN ISO 7093-1 and locking element

Tightening torques:

- electrical connections: 50 Nm \pm 15 % (M12 screw)
- mechanical screw connections: 25 Nm \pm 15 % (M8 screw)

Lifting Power Modules

The Power Modules can be lifted using the lifting holes. Use a lifting harness where the ropes or chains are maintained in a vertical position. The device must not be lifted at an angle because this can damage the housing. Rope spreaders may have to be used.

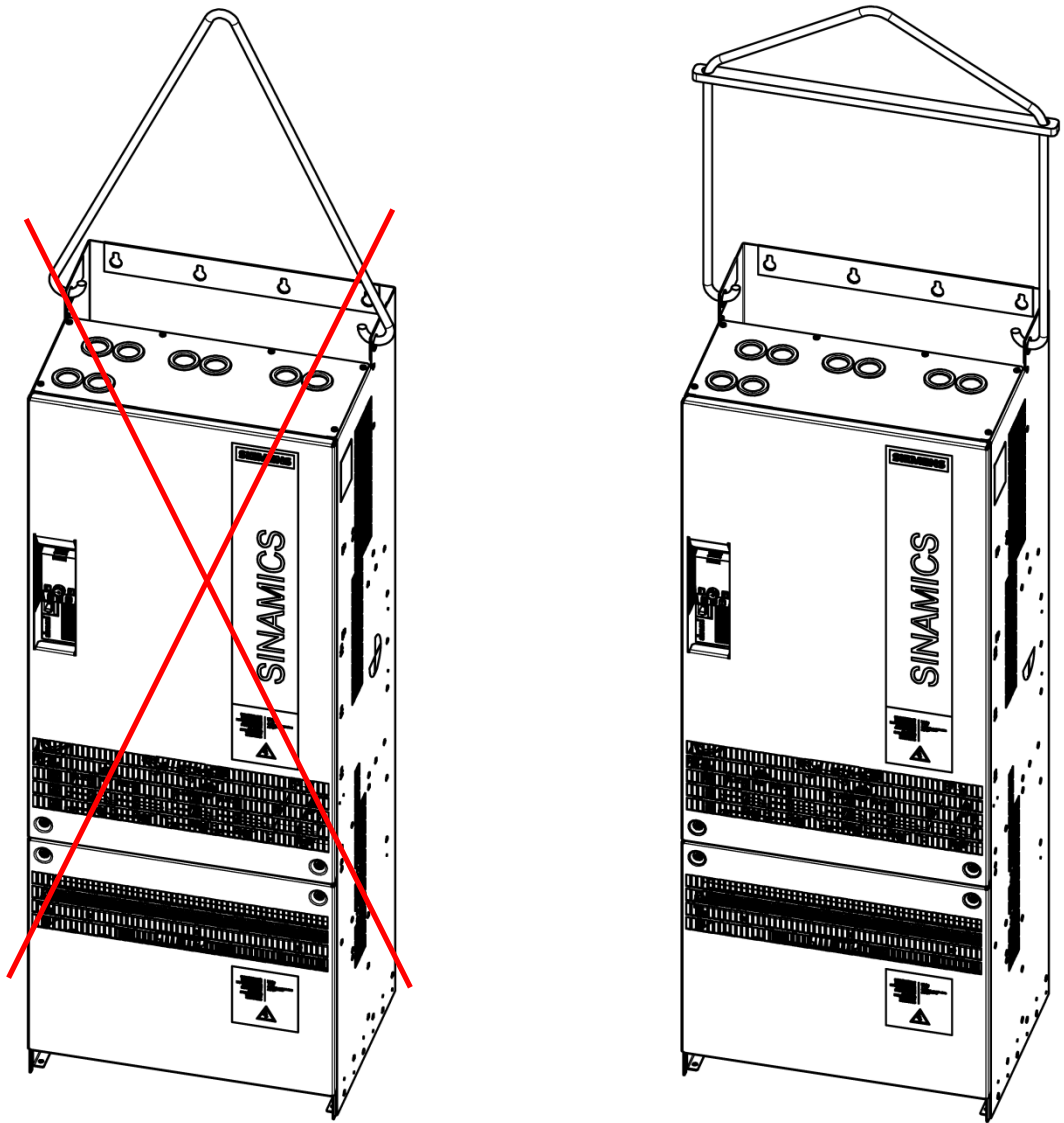

Figure 3-6 Example of lifting Power Modules (Frame size HX@380 V)

Lifting Power Modules to the cabinet

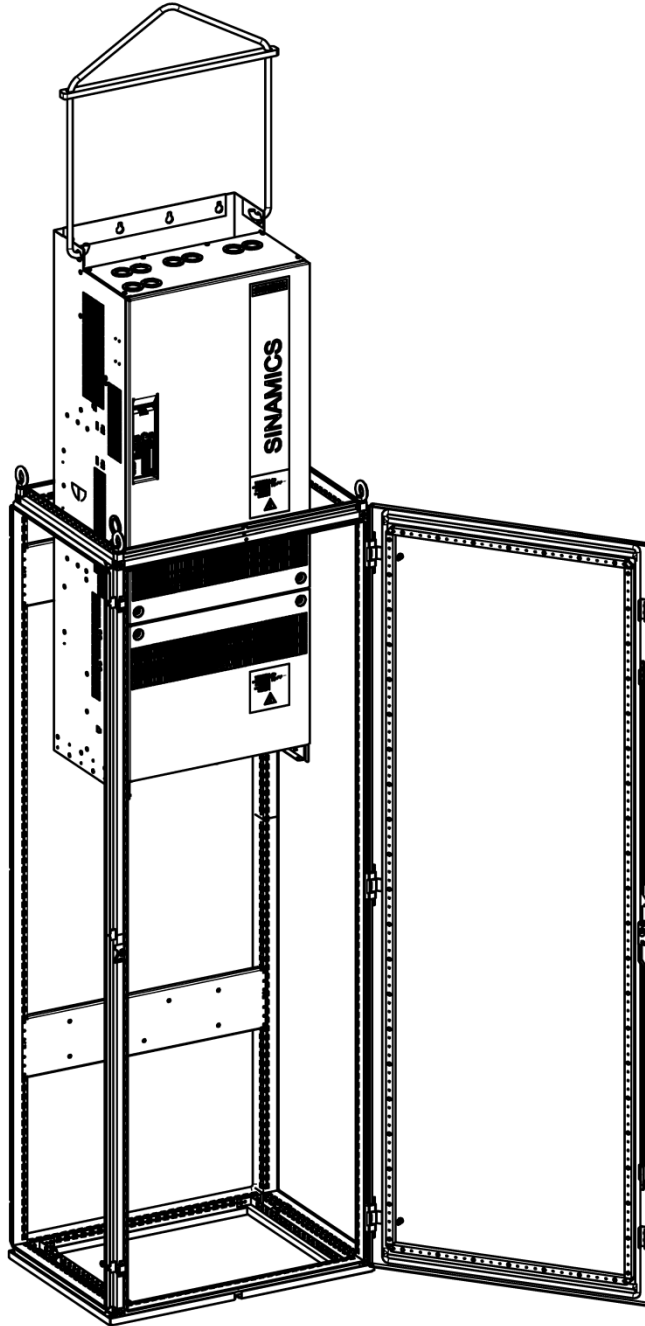

Figure 3-7 Example of lifting Power Modules to cabinet (Frame size HX@380 V)

Installation of power modules

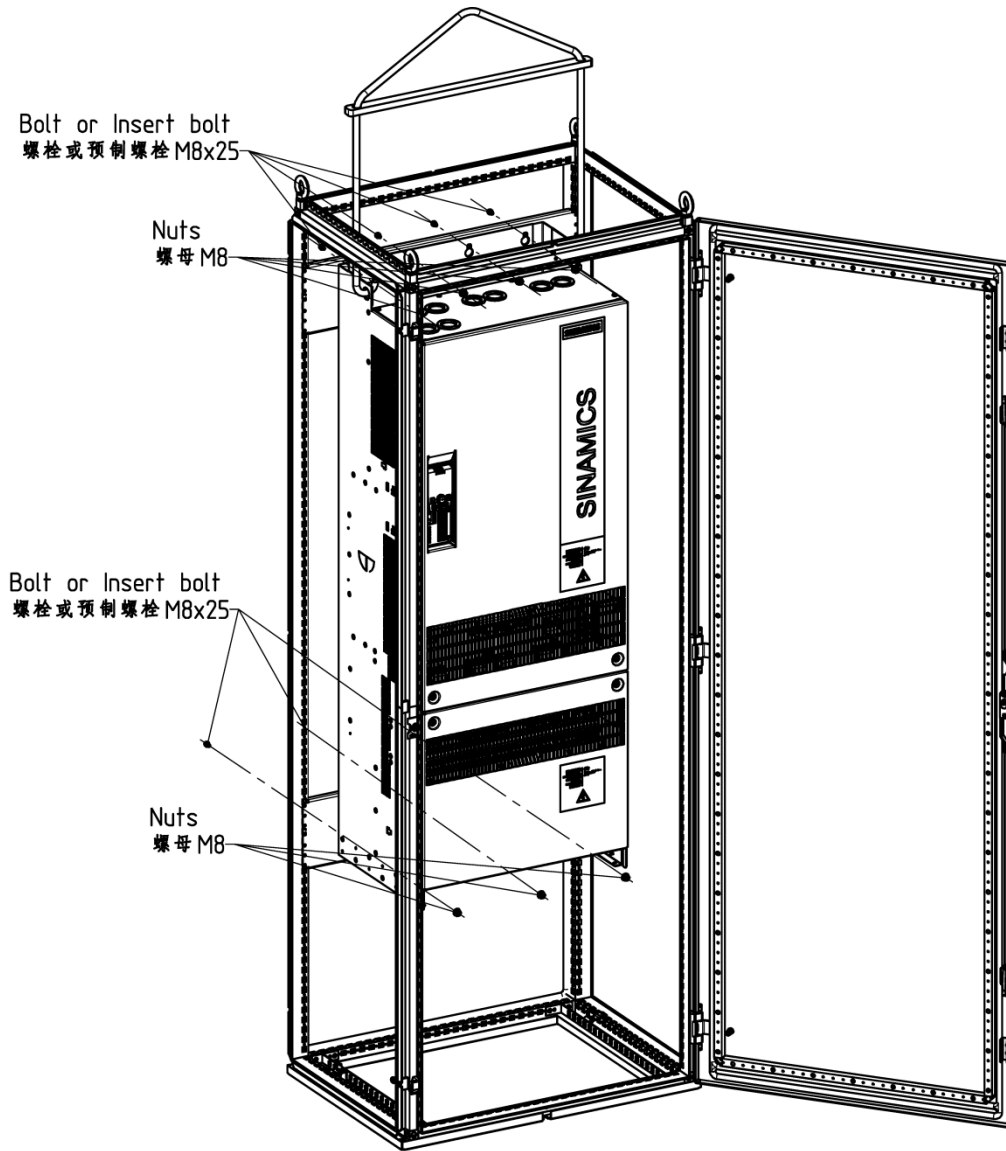

Figure 3-8 Example of power modules installation (Frame size HX@380 V)

Installation of frame plate

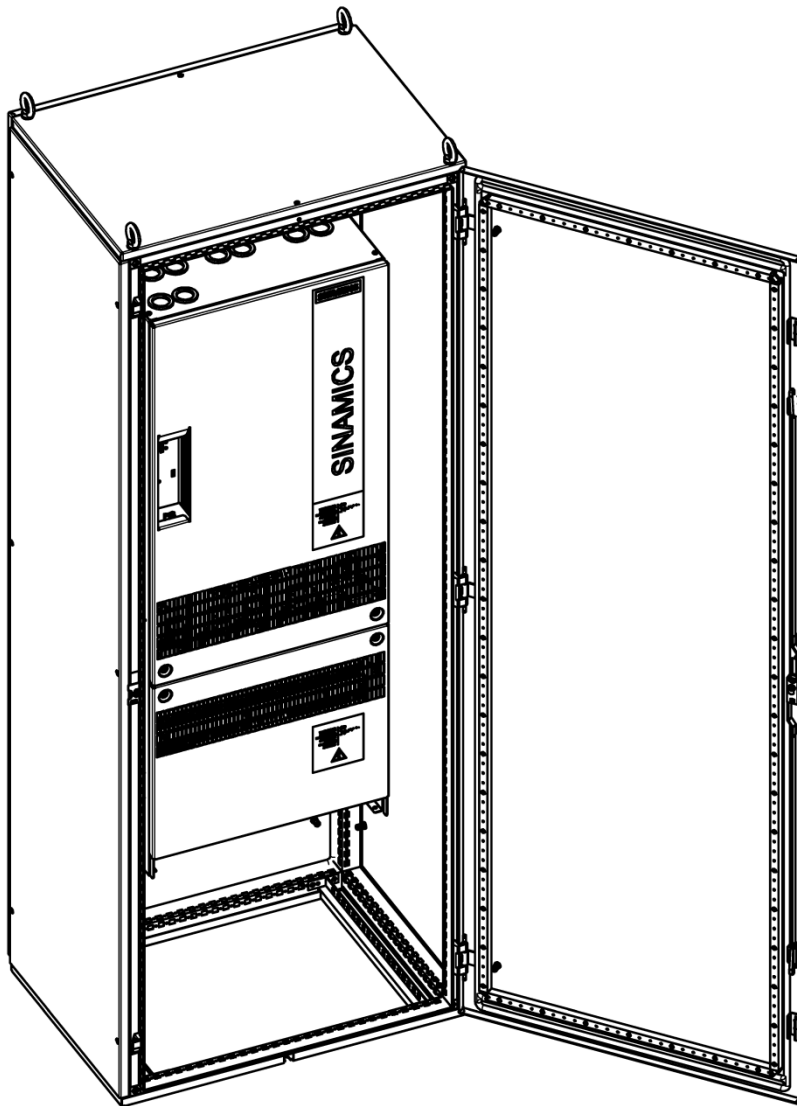

Figure 3-9 Example of frame plate installation (Frame size HX@380 V)

3.5.1 Chassis units

Drilling patterns, dimensions and clearances

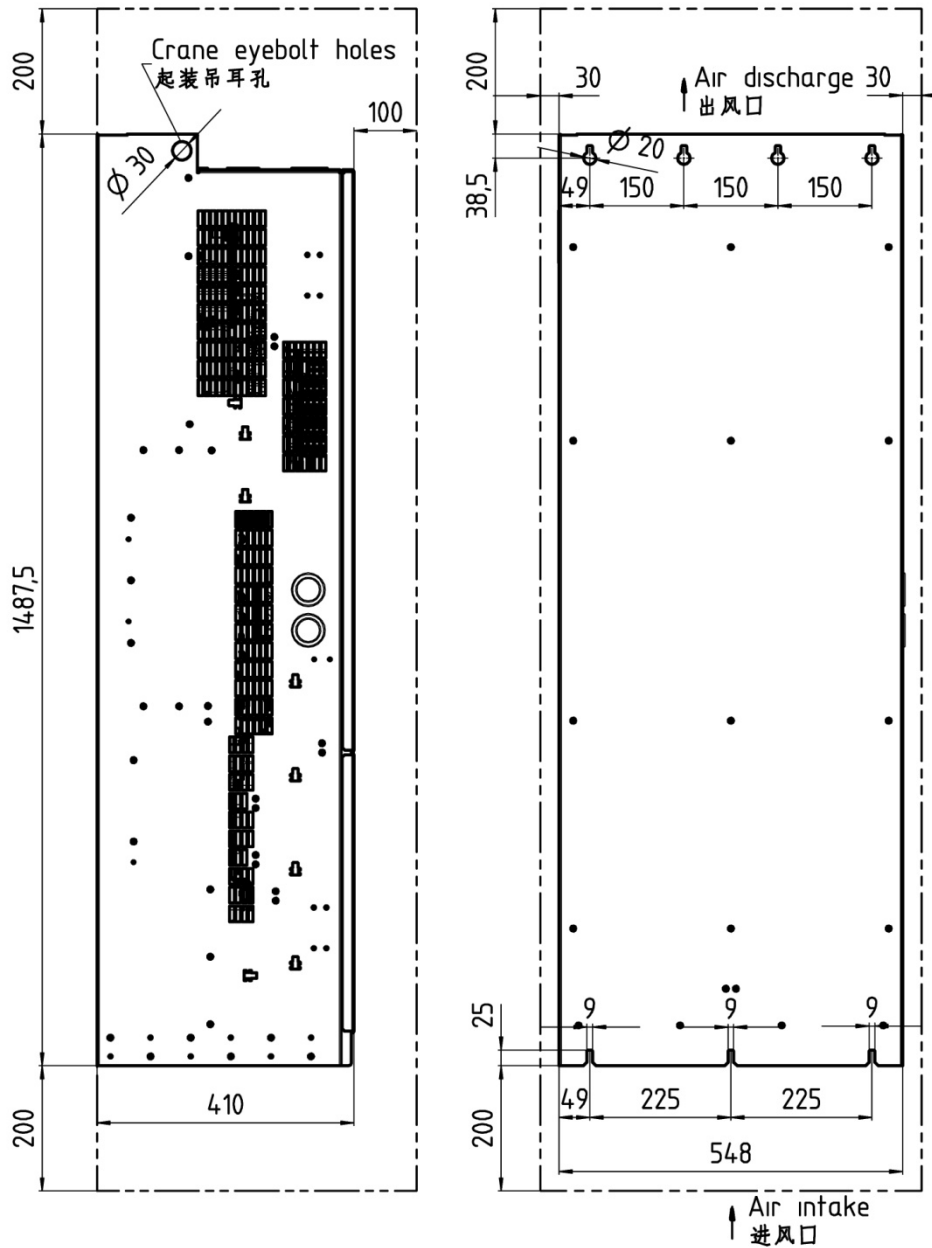

Figure 3-10 Dimension drawing of PM330L frame size HX@380 V, view from the side, view from the rear

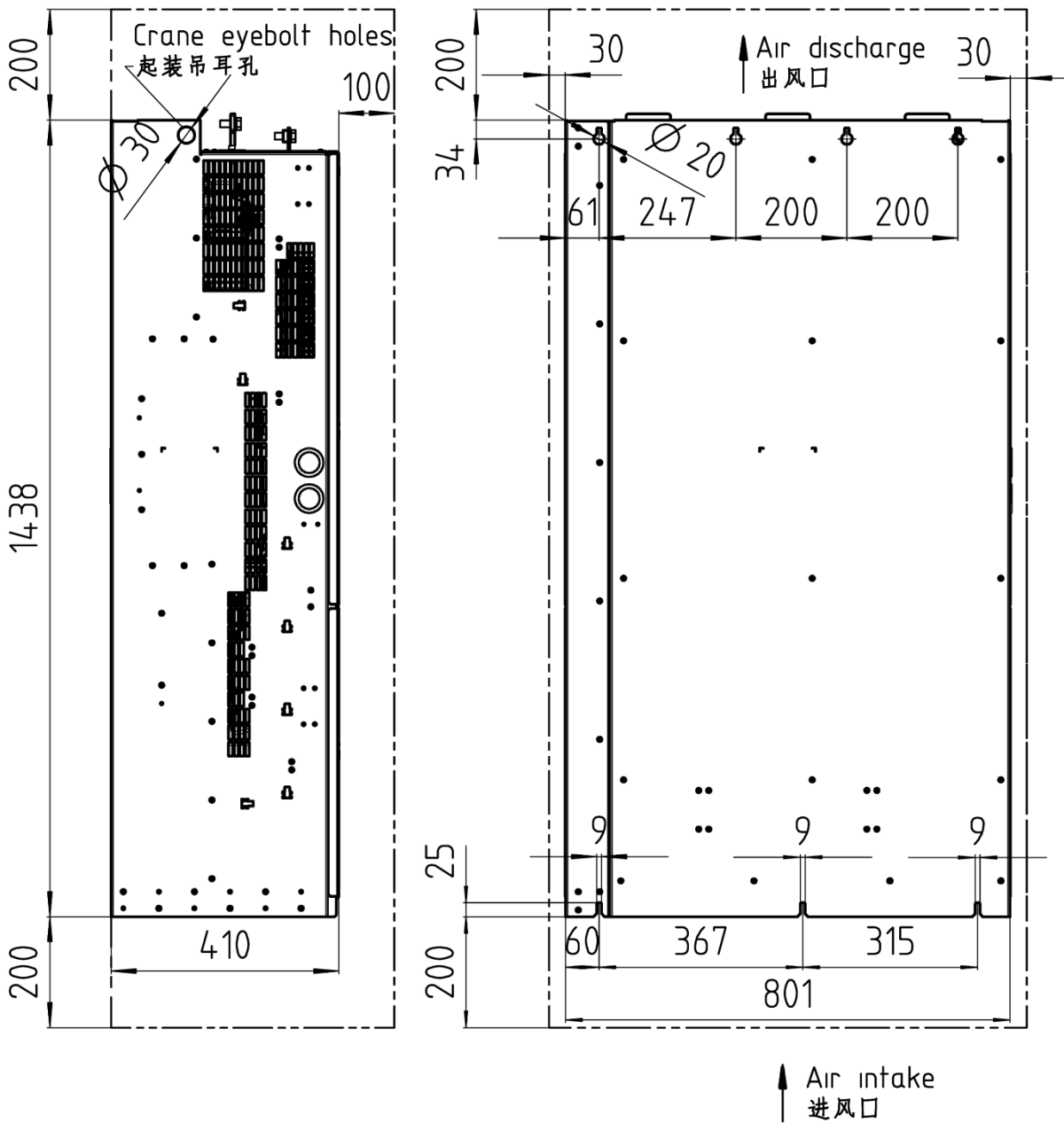

Figure 3-11 Dimension drawing of PM330L frame size JX@380 V, view from the side, view from the rear

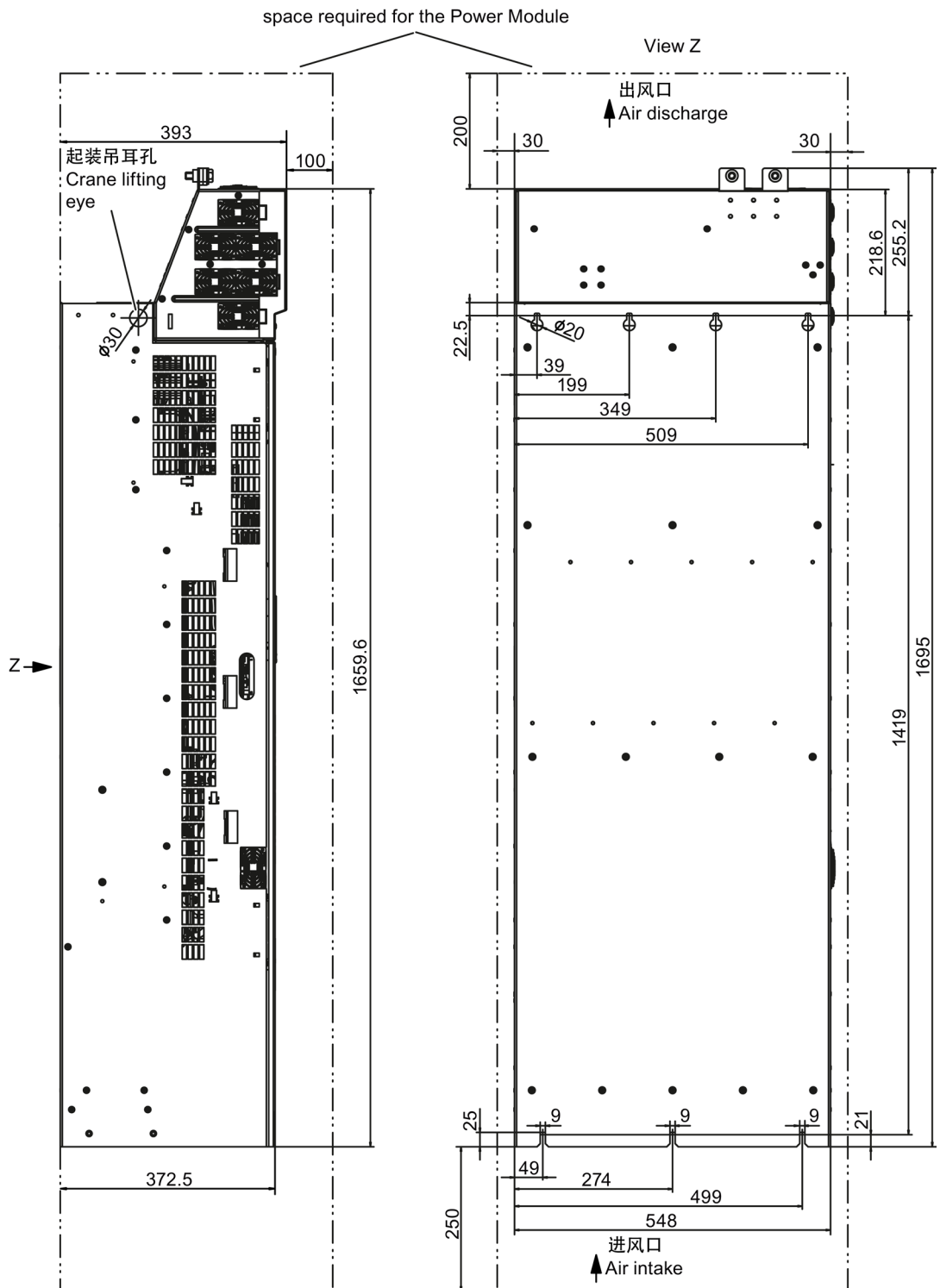

Figure 3-12 Dimension drawing of PM330L frame size HX@690 V, view from the side, view from the rear

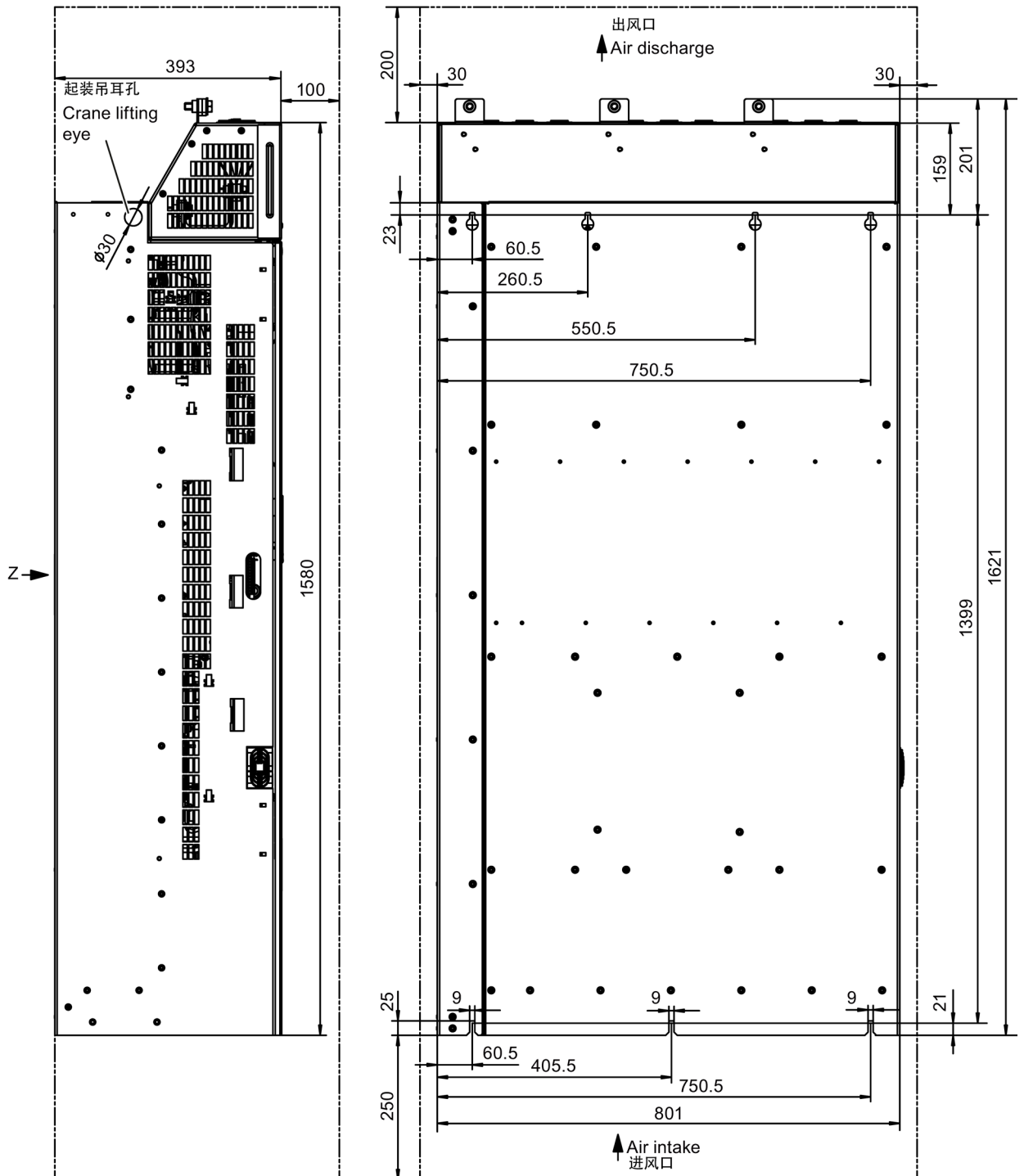



Figure 3-13 Dimension drawing of PM330L frame size JX@690 V, view from the side, view from the rear

3.6 Control Unit Installation

 WARNING
Danger to life due to voltage
The power unit must be safely power off before Control Unit Installation.

 WARNING
Danger to life if the fundamental safety instructions and remaining risks are not carefully observed
230 V AC can be connected via the relay outputs DO 0 and DO 2 of the Control Unit. These terminals can carry 230 V AC independent of the voltage condition of the Power Module. Therefore please observe appropriate safety measures when working on the inverter.

The Control Unit CU230P-2 and power module PM330L are **separately** ordered and delivered. As the alternative installation process, the accessory operating panel can be mounting to Control Unit at first or after control unit installation.



Figure 3-14 Operating panel installation

Before installing the Control Unit to power module, disassemble the retaining screws for housing cover (2 screws at below).

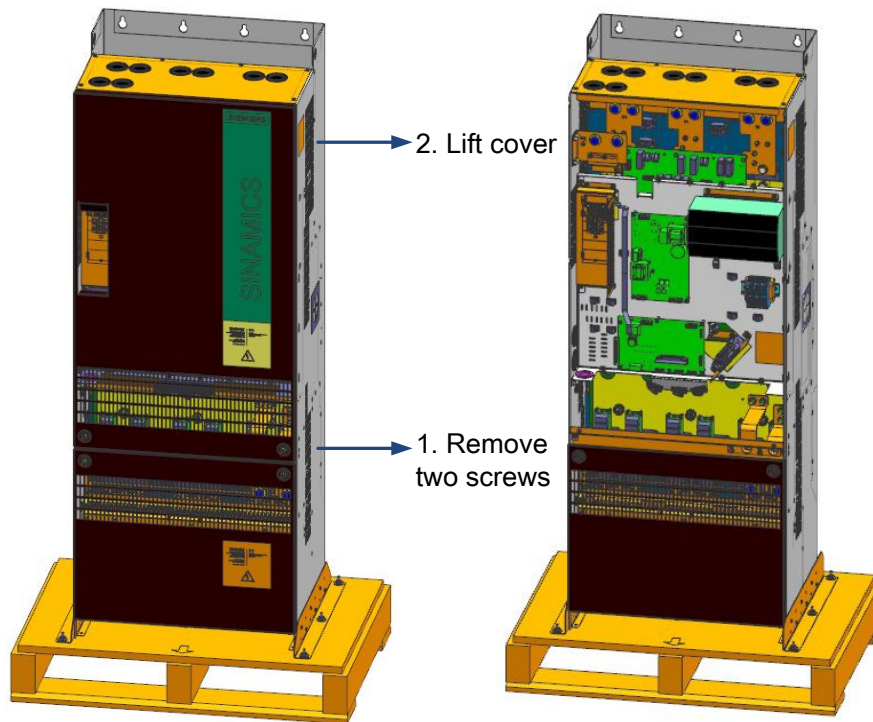

Figure 3-15 Remove front cover of frame size HX@380 V power unit

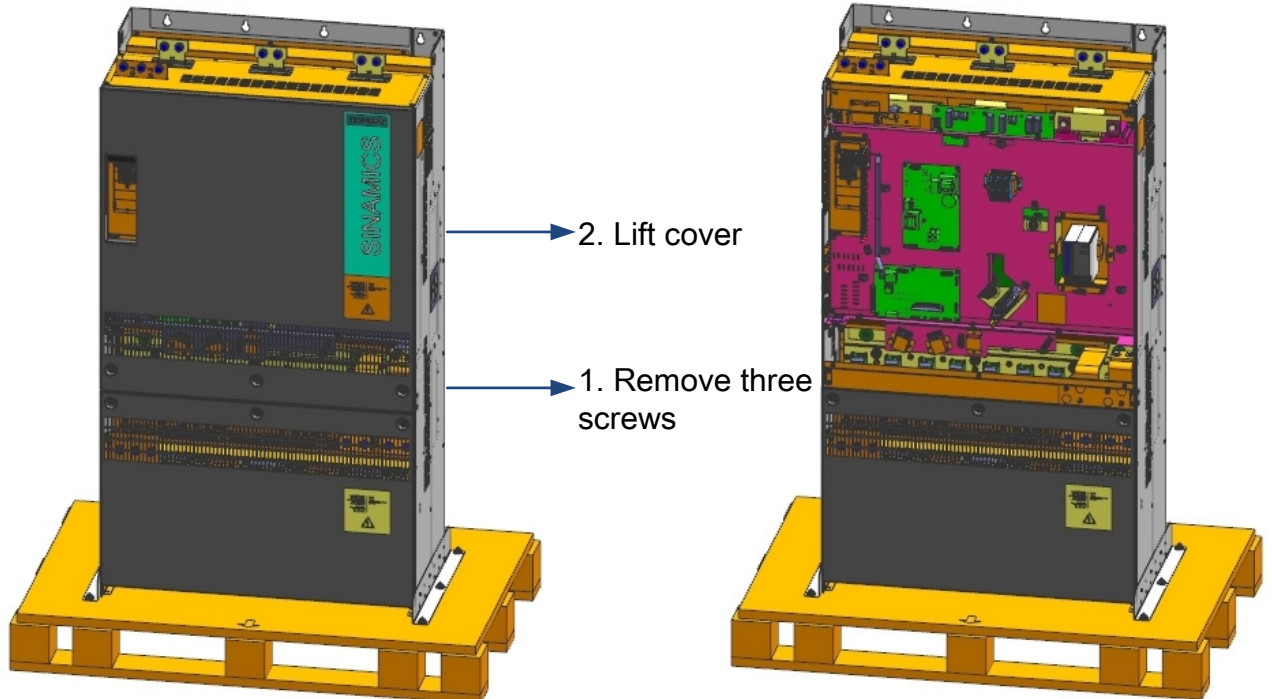

Figure 3-16 Remove front cover of frame size JX@380 V power unit

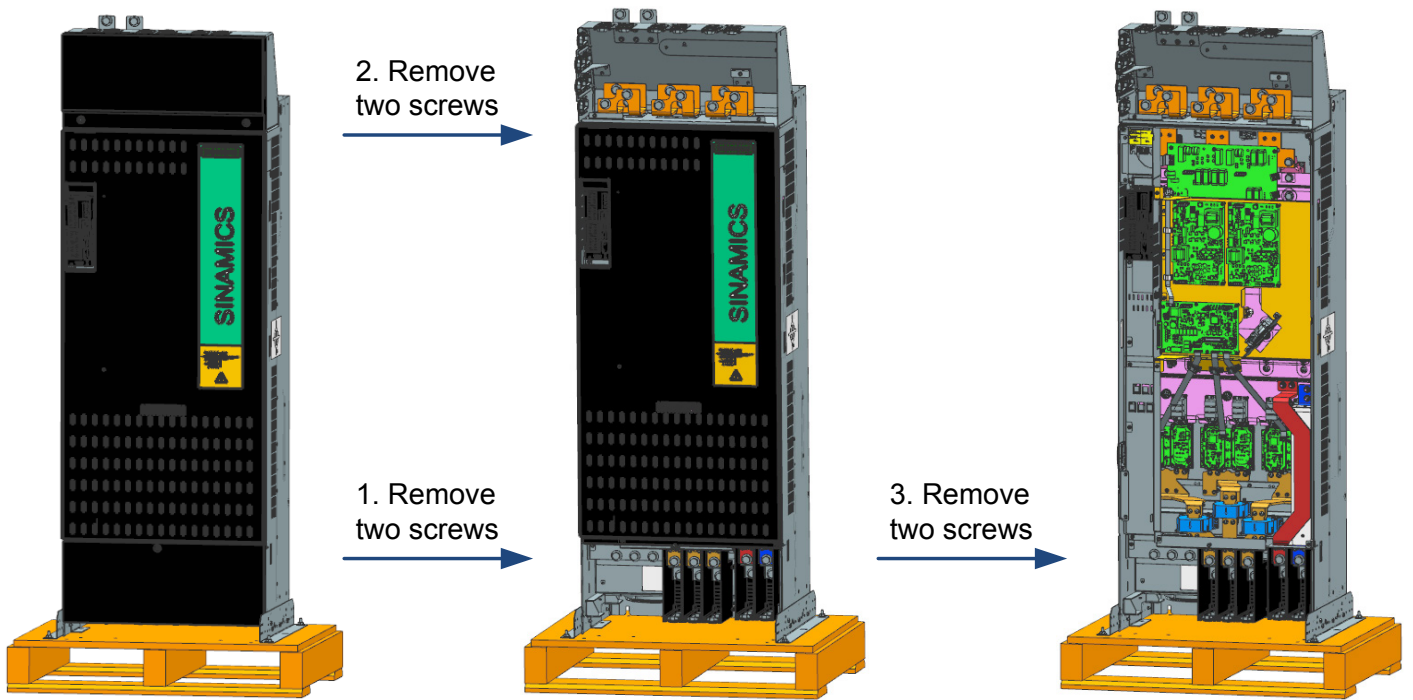

Figure 3-17 Remove front cover of frame size HX@690 V power unit

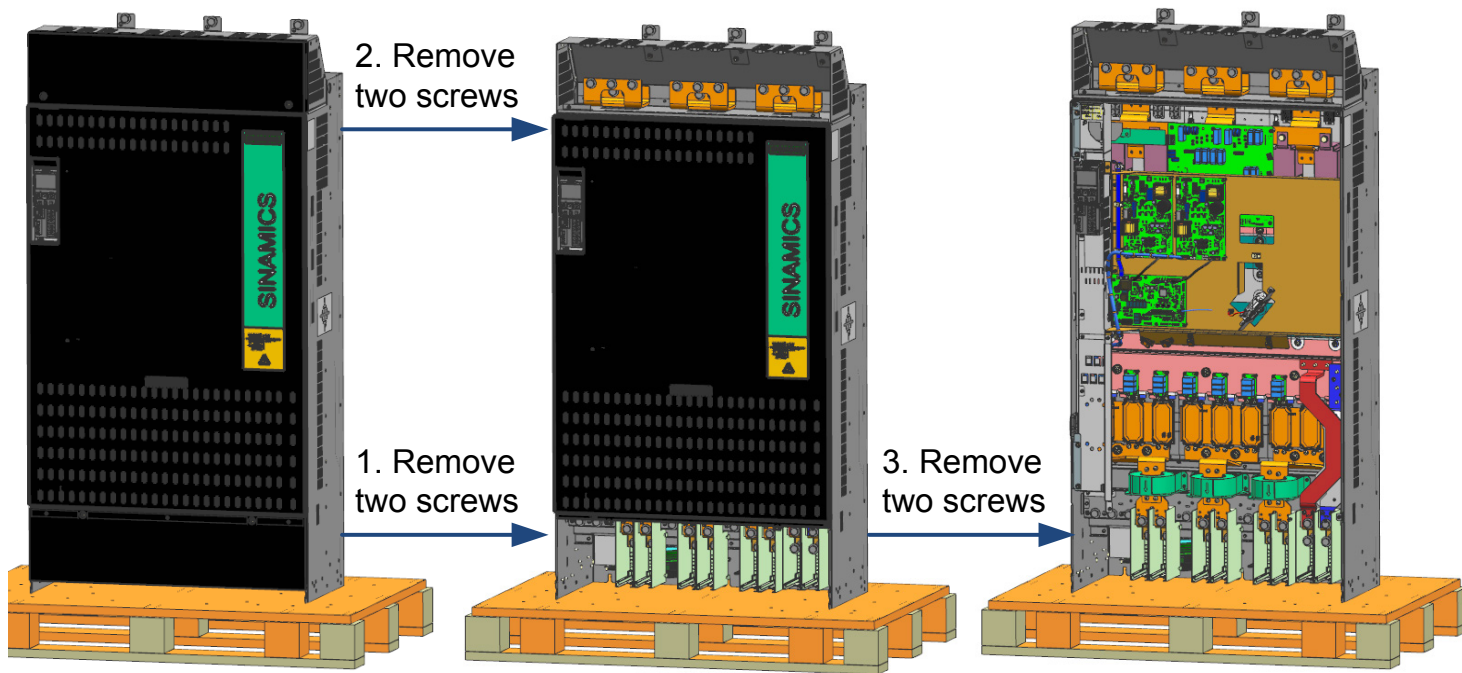

Figure 3-18 Remove front cover of frame size JX@690 V power unit

Then, plug the Control Unit to the power module. The Control Unit is always attached to the Power Module in the same fashion, irrespective of the type of Control Unit and Power Module size.

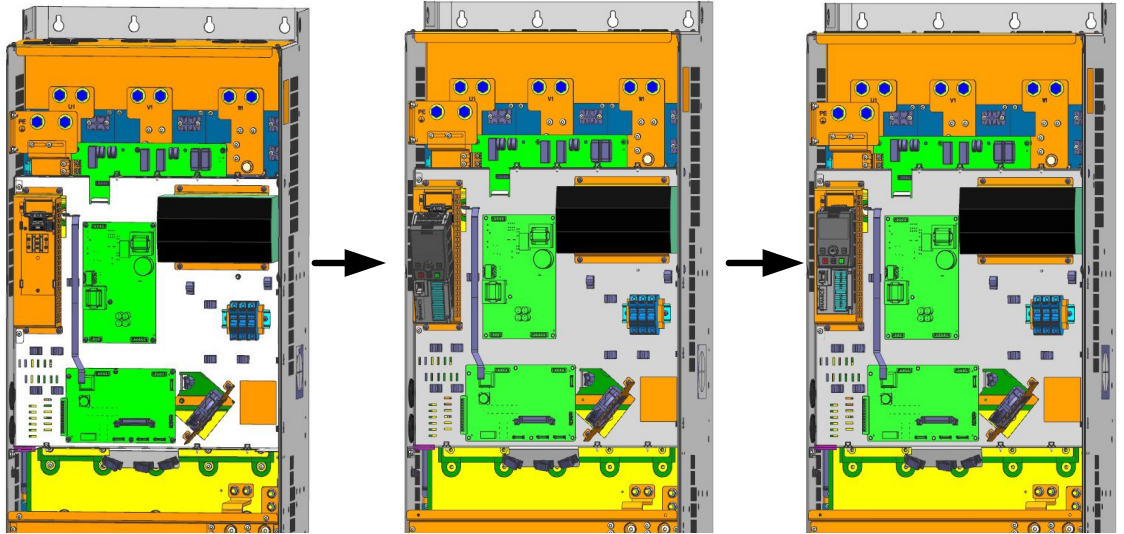

Figure 3-19 install the Control Unit CU230P-2 into frame size HX@380 V power unit

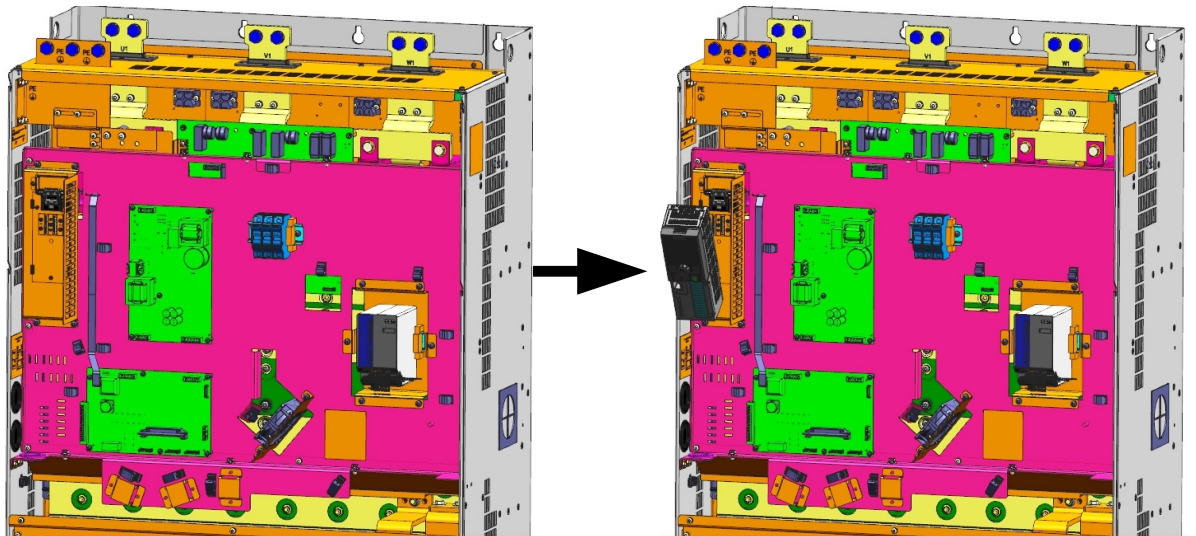

Figure 3-20 install the Control Unit CU230P-2 into frame size JX@380 V power unit

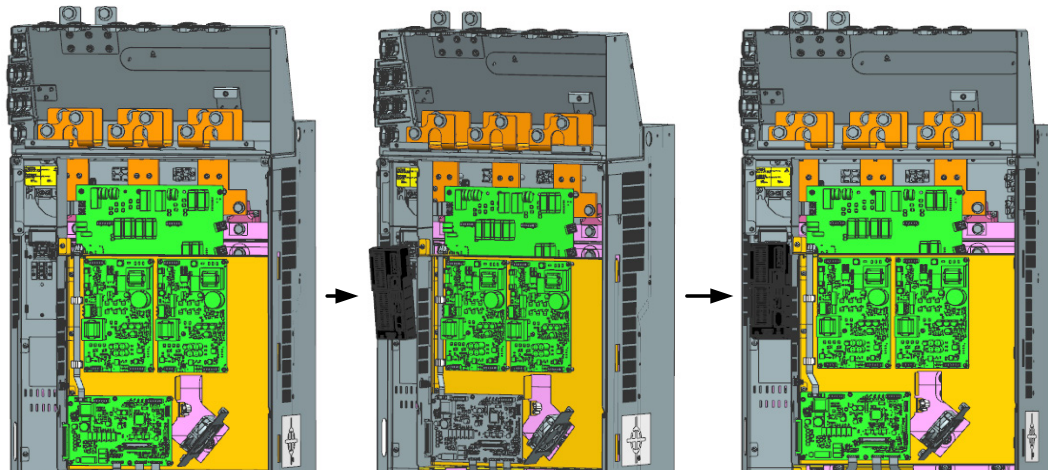

Figure 3-21 install the Control Unit CU230P-2 into frame size HX@690 V power unit

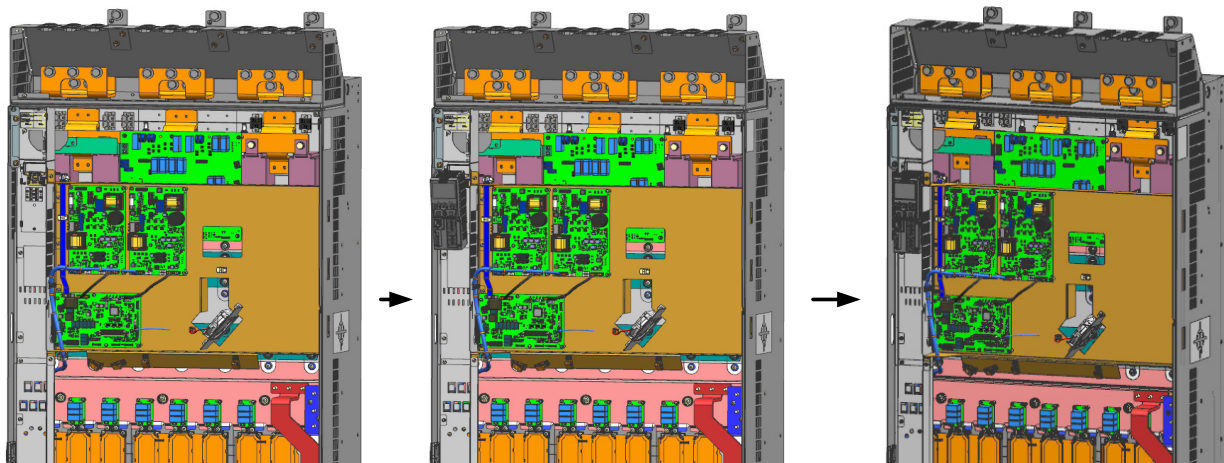
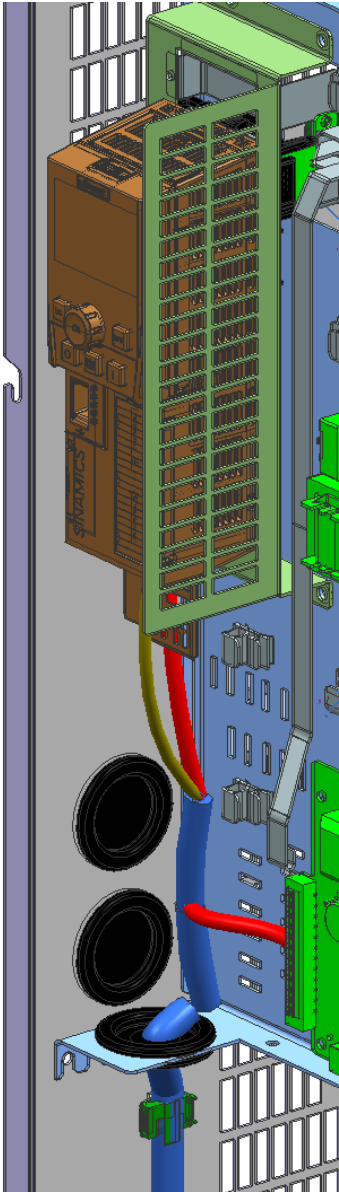

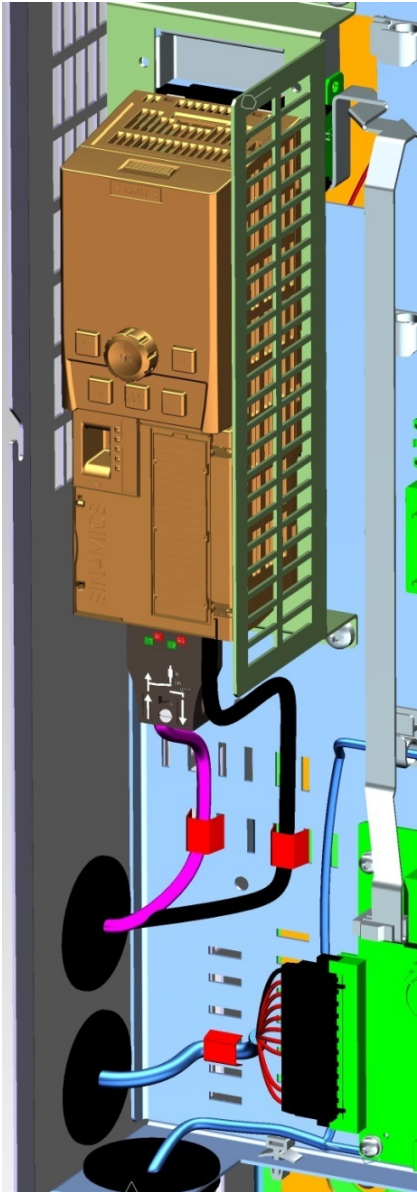

Figure 3-22 install the Control Unit CU230P-2 into frame size JX@690 V power unit

After that, insert the accessory memory card to Control Unit if order, and connect signal cables. Finally screw and mount the front cover.

3.7 Cable routing of Control Unit and X9 terminals

Table 3-1 Cable routing of control Unit CU230P-2 and X9 terminals

Wrong	Wrong	Correct
		

Connecting up, switching on

Preconditions

Line and motor connections can be established once the converter has been properly installed. It is crucial that the following notes are observed.

	WARNING
Danger to life if the fundamental safety instructions and remaining risks are not carefully observed	
The non-observance of the fundamental safety instructions and residual risks stated in Chapter Basic safety instructions (Page 7) can result in accidents with severe injuries or death.	
<ul style="list-style-type: none"> • Adhere to the fundamental safety instructions. • When assessing the risk, take into account residual risks. 	



	DANGER
Danger to life through electric shock due to the residual charge of the DC link capacitors	
Because of the DC link capacitors, a hazardous voltage is present for up to five minutes after the power supply has been switched off.	
Contact with live parts can result in death or serious injury.	
<ul style="list-style-type: none"> • Only open the device after five minutes have elapsed. • Measure the voltage before starting work on the DCP and DCN DC link terminals. 	



	WARNING
Danger to life due to high leakage currents caused by an interrupted external protective conductor	
The drive components conduct a high leakage current via the protective conductor. Touching conductive parts when the protective conductor is interrupted can result in death or serious injury.	
<ul style="list-style-type: none"> • Ensure that the external protective conductor satisfies at least one of the following conditions: <ul style="list-style-type: none"> – It has been laid so that it is protected against mechanical damage. ¹⁾ – If it is a single conductor, it has a cross-section of at least 10 mm² Cu. – If it is a conductor of a multi-conductor cable, it has a cross-section of at least 2.5 mm² Cu. – It has a second protective conductor in parallel with the same cross-section. – It complies with the local regulations for equipment with increased leakage current. 	
¹⁾ Cables laid within control cabinets or closed machine housings are considered to be adequately protected against mechanical damage.	

 **WARNING**

Danger of an accident due to missing warning labels in the national language.

Missing warning labels in the national language can result in death or serious injury.

- Attach the component warning labels in the national language.

Note

Overvoltage protection

To protect the units against line-side surge voltages, you are advised to install an overvoltage protection device directly at the infeed point (upstream of the main switch).

Note

Ensure that the appropriate circuit breakers or fuses with the specified current rating are connected between the power supply and the drive. The technical data contain information about the circuit breaker and fuses (see Specifications).

4.1 Access to power and motor terminals

Access to line and motor terminals of frame size HX@380 V power unit

The line and motor terminals are accessible via the following steps:

1. Release the 2 screws from the cover of the line connection terminals and remove the cover towards the front.
2. Release 2 screws from the cover of the motor connection terminals and remove the cover towards the front.

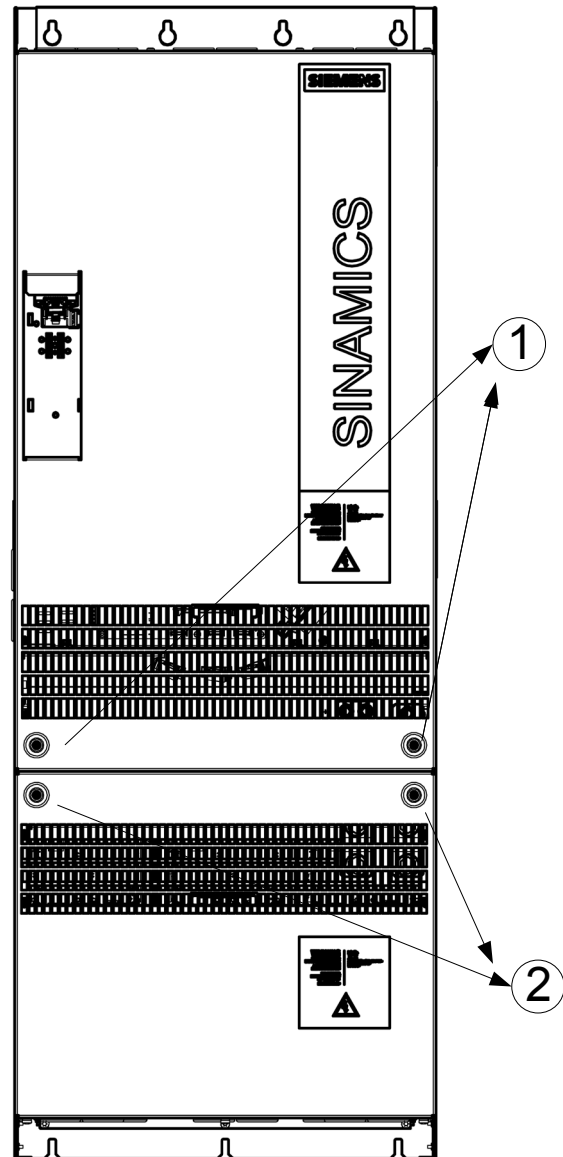

Access to line and motor terminals of frame size JX@380 V power unit

The line and motor terminals are accessible via the following steps:

1. Release the 3 screws from the cover of the line connection terminals and remove the cover towards the front.
2. Release 3 screws from the cover of the motor connection terminals and remove the cover towards the front.

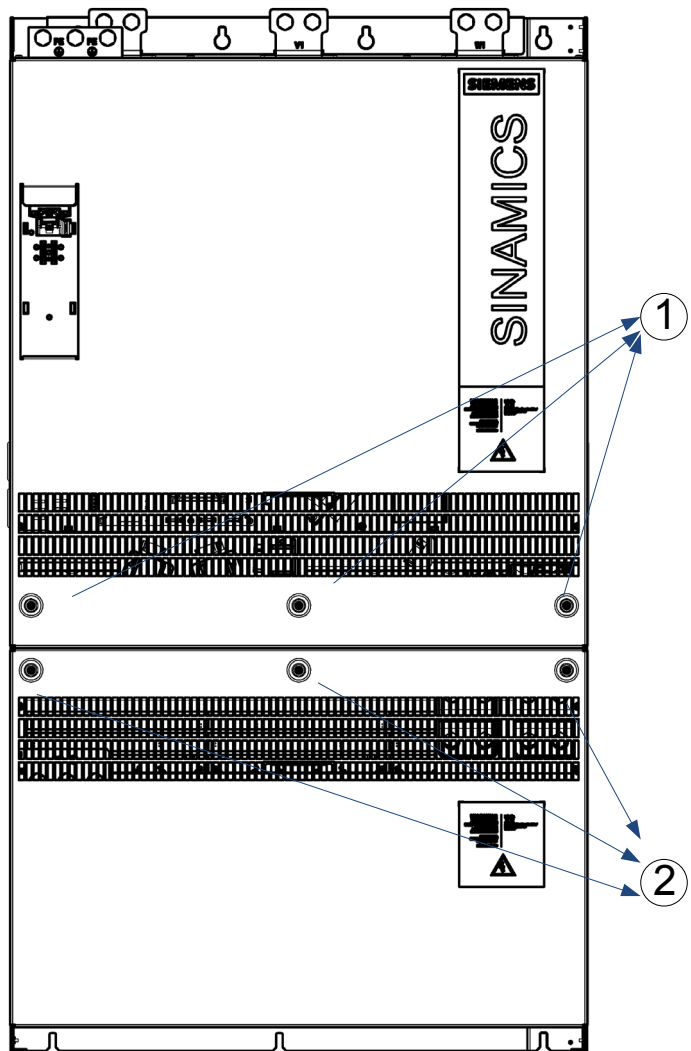

Access to line and motor terminals of frame size HX@690 V power unit

The line and motor terminals are accessible via the following steps:

1. Release the 1 screw from the lower cover of the motor connection terminals and remove the cover towards the front.
2. Release 2 screws from the upper cover of the line connection terminals and remove the cover towards the front.

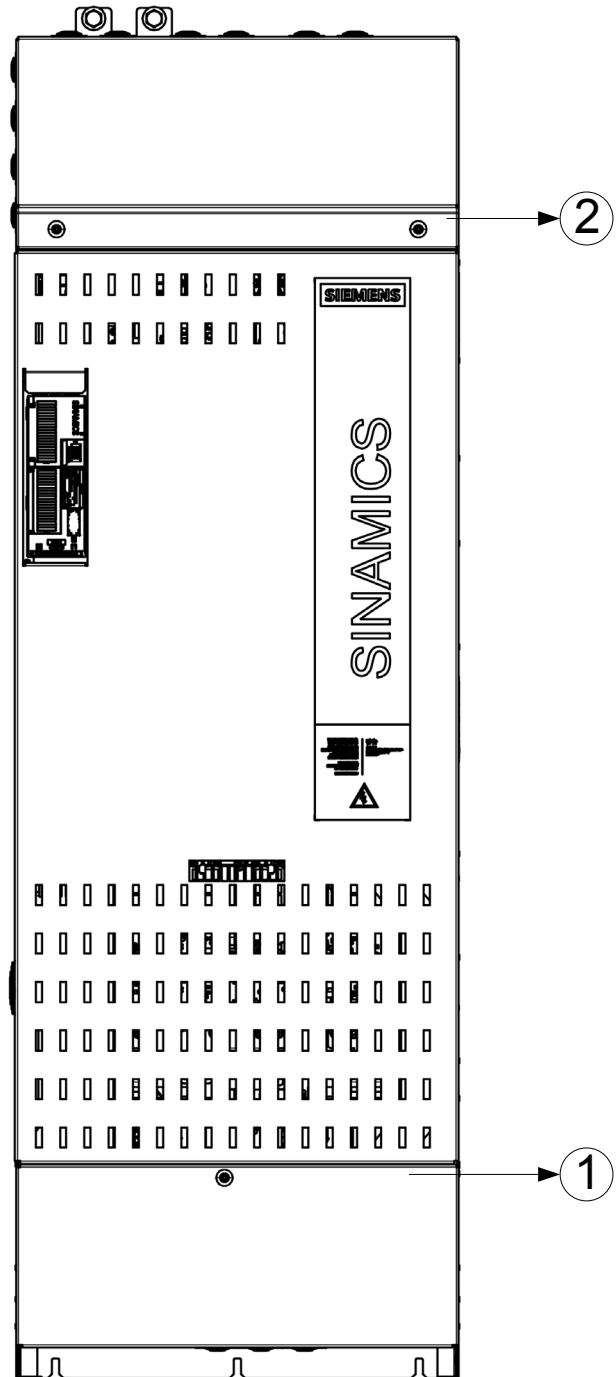

Access to line and motor terminals of frame size JX@690 V power unit

The line and motor terminals are accessible via the following steps:

3. Release the 2 screws from the lower cover of the motor connection terminals and remove the cover towards the front.
4. Release 2 screws from the upper cover of the line connection terminals and remove the cover towards the front.

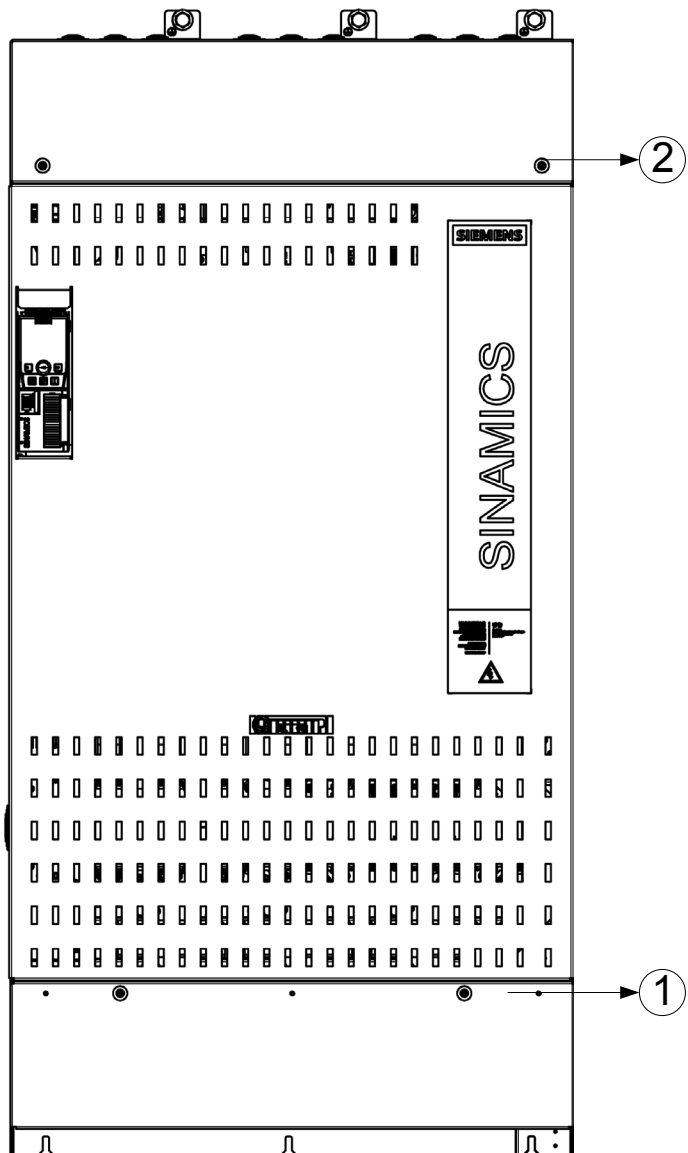

Line and motor terminals of frame size HX@380 V power unit

The diagram shows the layout of line and motor terminals, DC connection terminals and terminal strip X9.

Tightening torques for the line, motor and PE terminals (M12):
50 Nm

The cable entry protection must be broken out corresponding to the diameter of the cable to be introduced.

After connecting, the covers of the line and motor terminals must be reinstalled (tightening torque: 6 Nm).

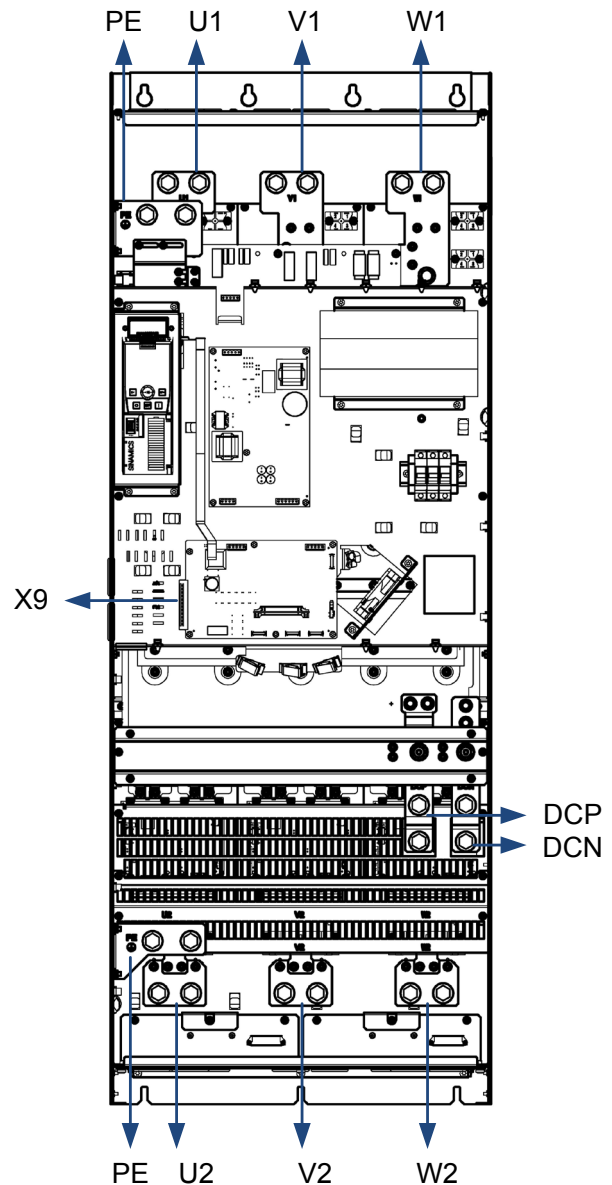

! WARNING

Danger to life through electric shock if the cable entry protection is not installed correctly.

A cable entry protection which is not broken out correctly may lead to dangerous touch voltage which can result in serious injury or death.

- Break the cable entry protection out in accordance with the required diameter of the cable in order to ensure degree of protection IP20.

Line and motor terminals of frame size JX@380 V power unit

The diagram shows the layout of line and motor terminals, DC connection terminals and terminal strip X9.

Tightening torques for the line, motor and PE terminals (M12): 50 Nm

The cable entry protection must be broken out corresponding to the diameter of the cable to be introduced.

After connecting, the covers of the line and motor terminals must be reinstated (tightening torque: 6 Nm).

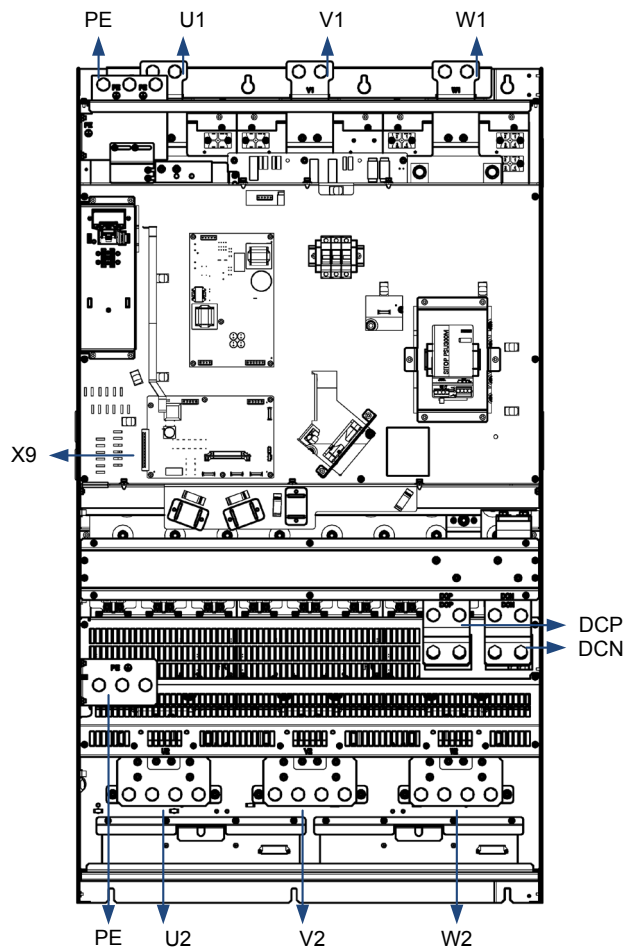

! WARNING

Danger to life through electric shock if no prevent to touch power connection terminals

No cable entry protection for frame size JX@380 V power unit, which may lead to dangerous touch voltage.

- The power unit must be built in at least IP20 protection degree enclosure, and prevent measure against electric shock must be adopted.

Line and motor terminals of frame size HX@690 V power unit

The diagram shows the layout of line and motor terminals and terminal strip X9.

Tightening torques for the line, motor and PE terminals (M12):
50 Nm

The cable entry protection for the line connection (①) must be broken out corresponding to the diameter of the cable to be introduced.

The cable entry protection for the motor connection is described in the following section.

After connection, the covers of the line and motor terminals must be reinstalled (tightening torque: 6 Nm).

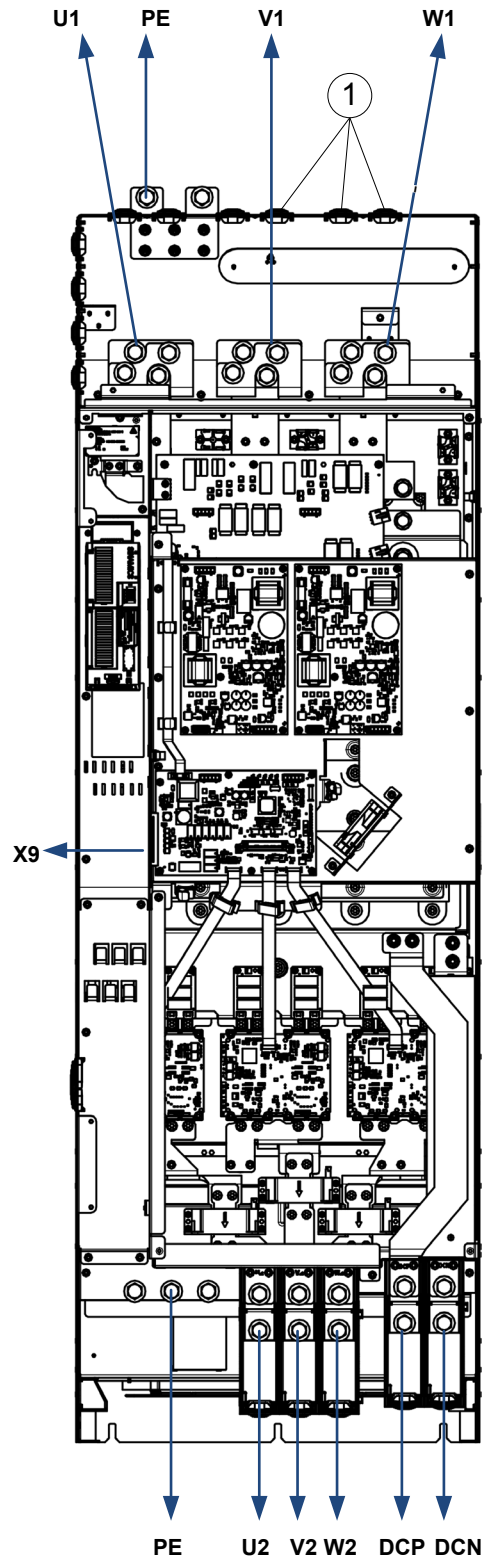

Line and motor terminals of frame size JX@690 V power unit

The diagram shows the layout of line and motor terminals and terminal strip X9.

Tightening torques for the line, motor and PE terminals (M12): 50 Nm

The cable entry protection for the line connection (①) must be broken out corresponding to the diameter of the cable to be introduced.

The cable entry protection for the motor connection is described in the following section.

After connection, the covers of the line and motor terminals must be reinstalled (tightening torque: 6 Nm).

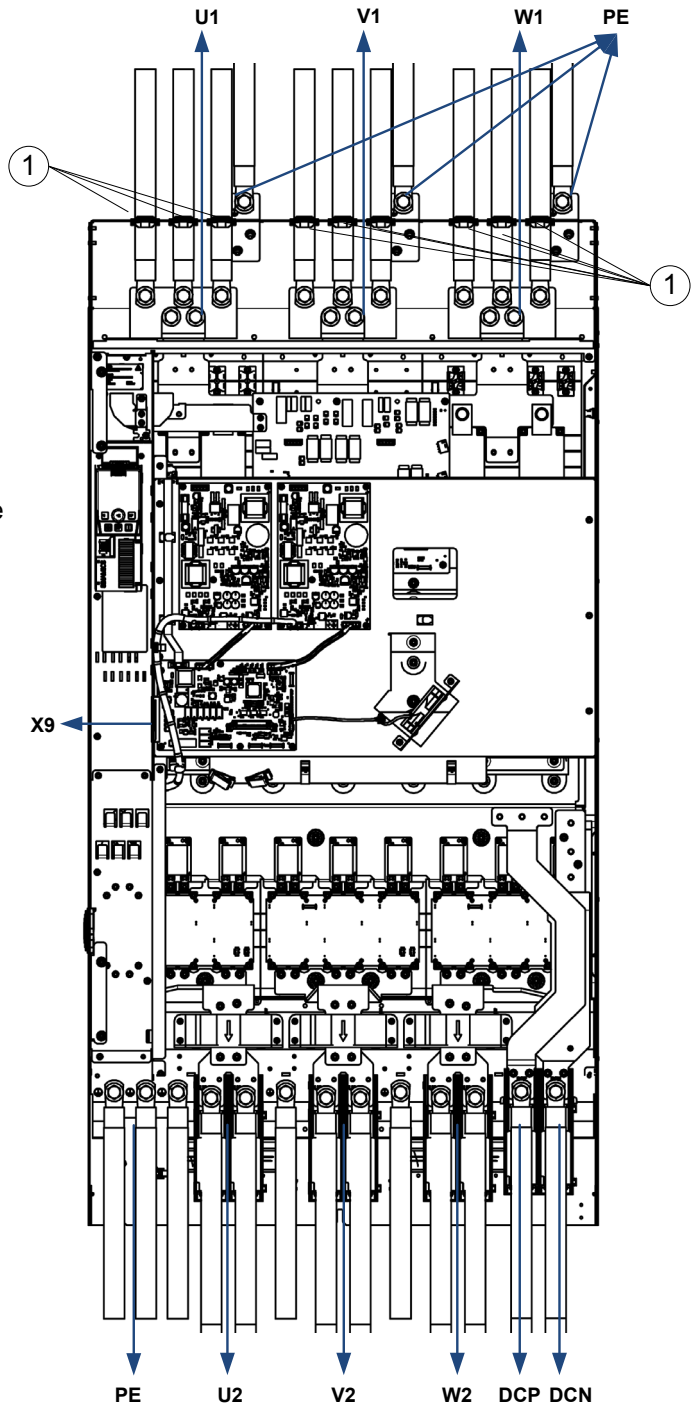



! WARNING

Danger to life as a result of electric shock when the line feeder cable installation is damaged

If the line feeder cables are incorrectly routed, the insulation can be damaged when coming in contact with the sharp edges of the PE connecting lugs - which can result in a short-circuit.

- When routing the line feeder cables, ensure that the insulation does not come into contact with the PE connecting lugs.

Output connection for 690V power unit

When using the front connections for U2, V2, W2, DCP, DCN, the front cable entry protection must be broken out according to the cable diameter to be introduced.

When using the rear connections for U2, V2, W2, DCP, DCN, the plastic panel (②) of the connection housing must be broken out and used at the point of the cable entry protection from the accessory pack according to the cable diameter to be introduced.

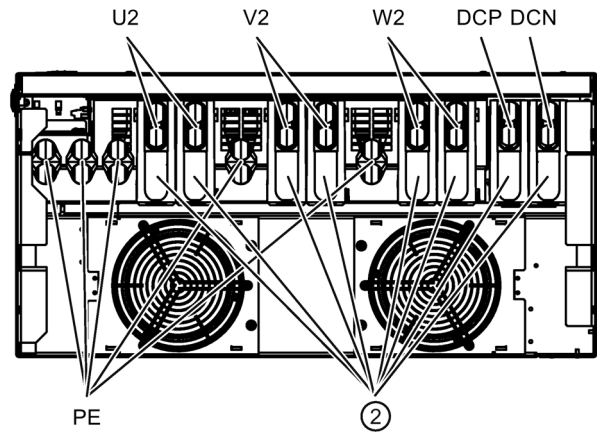

! WARNING

Danger to life through electric shock if the cable entry protection is not installed correctly.

A cable entry protection which is not broken out correctly may lead to dangerous touch voltage which can result in serious injury or death.

- Break the cable entry protection out in accordance with the required diameter of the cable in order to ensure degree of protection IP20.

4.2 Line, motor and DC link connection

Arrangement of the converter terminals, see Access to power and motor terminals (Page 45).

For all connections, carefully observe EMC regulations, see EMC compliant connection (Page 64).

4.2.1 Protective conductor



WARNING

Danger to life caused by high leakage currents for an interrupted protective conductor

The drive components conduct a high leakage current via the protective conductor. Touching conductive parts when the protective conductor is interrupted can result in death or serious injury.

- Dimension the protective conductor as stipulated in the appropriate regulations.

Dimensioning the protective conductor

Observe the local regulations for protective conductors subject to an increased leakage current at the site of operation.

The minimum cross-section of all protective conductors routed in the control cabinet depends on the cross-section of the line or motor feeder cable:

- Line or motor feeder cable $\leq 16 \text{ mm}^2$

⇒ Minimum cross-section of the protective conductor = cross-section of the line or motor feeder cable

- $16 \text{ mm}^2 < \text{line or motor feeder cable} \leq 35 \text{ mm}^2$

⇒ Minimum cross-section of the protective conductor = 16 mm^2

- Line or motor feeder cable $> 35 \text{ mm}^2$

⇒ Minimum cross-section of the protective conductor = $\frac{1}{2}$ cross-section of the line or motor feeder cable

Additional requirements placed on the protective conductor of the line feeder cable:

- For permanent connections, the protective conductor must fulfill at least one of the following conditions:
 - The protective conductor is routed so that it is protected against damage along its complete length.
Cables routed inside electrical cabinets or enclosed machine housings are considered to be adequately protected against mechanical damage.

- As a conductor of a multi-conductor cable, the protective conductor has a cross-section $\geq 2.5 \text{ mm}^2 \text{ Cu}$.
- For an individual conductor, the protective conductor has a cross-section $\geq 10 \text{ mm}^2 \text{ Cu}$.
- The protective conductor consists of two conductors with the same cross-section.
 - When connecting a multi-conductor cable using an industrial plug connector according to EN 60309, the protective conductor must have a cross-section of $\geq 2.5 \text{ mm}^2 \text{ Cu}$.

4.2.2 Line connection

Open the terminal covers of the converter.

Connect the protective conductor of the power supply cable to terminal PE of the inverter.

Connect the power supply cable to terminals U1, V1 and W1.

When using copper busbars, the same cross-sections should be used as the connecting busbars of the device itself:

Rated power / kW	Cross-connection of connection copper busbar / mm ²
3AC, 380...440 V	
280	60 x 6
315	
355	
400	
450	80 x 6
500	
560	80 x 8
3AC, 500...690 V	
280	64 x 8
315	
355	
400	
450	80 x 8
500	
560	
630	

NOTICE
Damage to the device through not removing the connection clip with a non-grounded line supply
In case of operation on non-grounded line supply (IT system), open the connection to the basic interference suppression module refer to chapter 4.4.

4.2.3 Length of motor cables

With the following cable lengths, the inverters operate according to the datasheet specifications:

Table 4- 1 Permissible cable length depending on the EMC category

Cable used	Maximum cable lengths	EMC category (according to IEC 61800-3)
Shielded cable, devices with external line filter	100 m	C2 *)
Shielded cable, devices without external line filter	100 m	C3 *)

*) EMC-compliant connection required, also see EMC compliant connection (Page 64)

Table 4- 2 Maximum cable lengths

Cable used	Maximum cable lengths	Output filter
Shielded cable, devices without output filter	100 m	--
Unshielded cable, devices without output filter	200 m	--
Shielded cable, devices with output filter	300 m	Output reactor, du/dt filter
	100 m	du/dt filter compact
Unshielded cable, devices with output filter	450 m	Output reactor, du/dt filter
	150 m	du/dt filter compact

4.2.4 Motor connection

Star and delta connection

Siemens motors have a diagram inside the terminal box showing both connection methods:

- Star connection (Y)
- Delta connection (Δ)

The motor rating plate provides data about the correct connection.

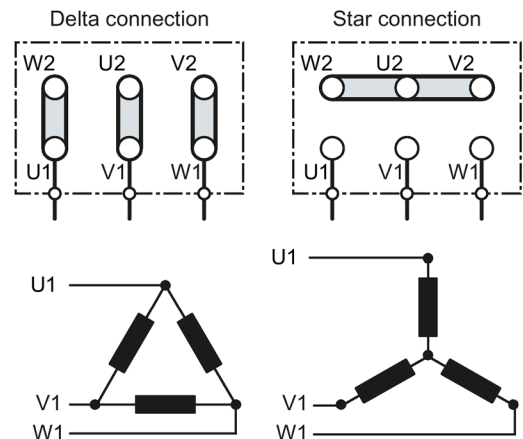

Connecting the motor to the converter

Connect the protective conductor of the motor to the ⏚ terminal of the converter.

Connect the motor cable to terminals U2, V2 and W2.

If available, close the terminal covers of the converter.

4.2.5 DC link connection for external Braking Module

The PM330L Power Modules permit an external Braking Module to be connected via the DCP and DCN DC link connection terminals.

Characteristic data of the connecting terminals (@ $U_{\text{line rated}}$ 380 V – 480 V / 500 V – 600 V / 690 V):

- Supply voltage: up to 780 V / 970 V / 1160 V DC
- Current carrying capacity:
 - At a 40 °C ambient temperature:
 - 65 A / 52 A / 44 A continuous
 - 260 A / 210 A / 173 A for a 22 % mark-to-space ratio (20 s on, 70 s off)
 - At a 50 °C ambient temperature:
 - 49 A / 39 A / 33 A A continuous
 - 195 A / 158 A / 130 A for a 22 % mark-to-space ratio (20 s on, 70 s off)

A Braking Module is not available for the PM330 Power Modules for line voltages 3 AC 500 - 690 V.

Supplementary rectifier for higher pulse line harmonics

When using DC link connecting terminals DCP and DCN as infeed for an external supplementary rectifier (current carrying capability, see the appropriate table in the Technical data), the rectifier must have as a minimum a fully-controlled 6-pulse thyristor three-phase bridge or an un-controlled 6-pulse diode three-phase bridge and a 2 % line reactor.

The system (infeed transformer, reactor, busbars, fuses, ...) must be designed so that the current distribution of the individual subrectifiers corresponds to the theoretically expected value.

The short-circuit and overload protection must be adapted.

Note

It is only permissible to switch-on the supplementary rectifier if the DC link was precharged by the Power Module.

Signal X9.8:"DC Link Charged" can be used for this purpose.

4.3 Cable lugs

Cable lugs

The cable connections on the devices are designed for cable lugs according to DIN 46234.

For connection of alternative cable lugs, the maximum dimensions are listed in the table below.

These cable lugs are not to exceed these dimensions, as mechanical fastening and adherence to the voltage distances is not guaranteed otherwise.

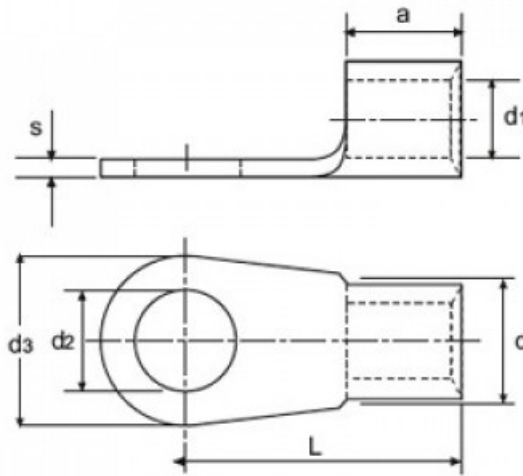

Figure 4-1 Dimensions of the cable lugs

Table 4-3 Dimensions of the cable lugs

Screw / bolts	Connection cross-section [mm ²]	a [mm]	c [mm]	d2 [mm]	d3 [mm]	l [mm]
M12	240	32	36	13	38	56

4.4 Open the connection to the basic interference suppression module for operation on IT system

If the built-in unit is operated from a non-grounded supply (IT system), the connection to the basic interference suppression module of the Power Module must be opened.

NOTICE

Damage to the device through not removing the connection clip with a non-grounded line supply

Failure to open the connection to the basic interference suppression module on a non-grounded line supply (IT system) can cause significant damage to the device.

- With a non-grounded line supply (IT system) open the connection to the basic interference suppression module.

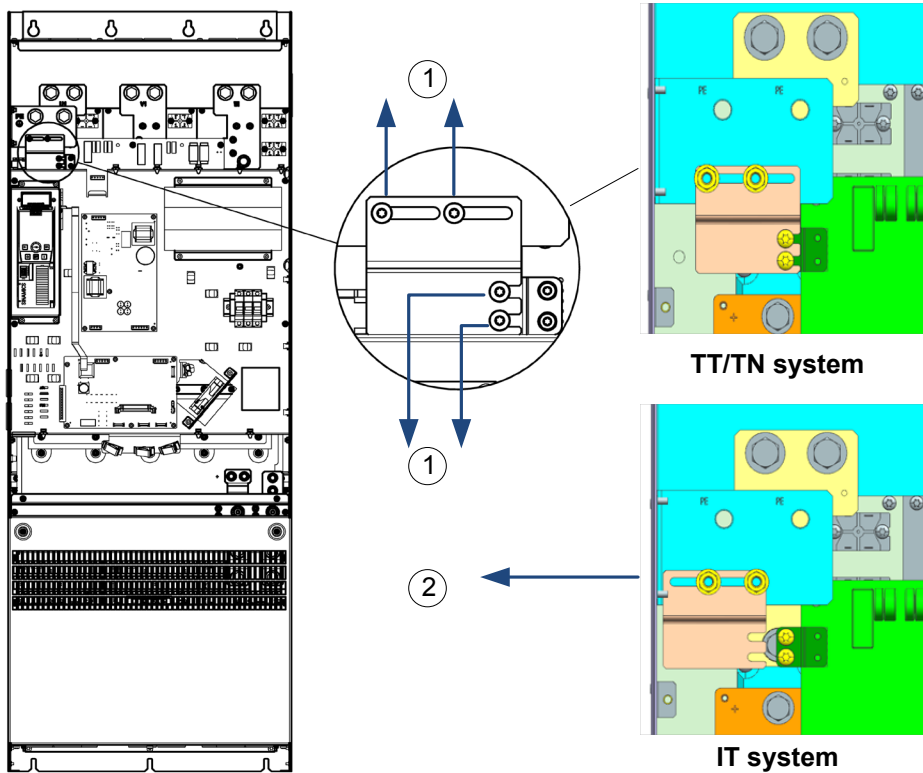

Figure 4-2 Opening the connection to the basic interference suppression module for 380 V power units.

The connection is opened as follows:

1. Opening the housing cover and release the four screws ①, but do not remove the screws.
2. Sliding the connection clip towards the left, until the connection clip are disconnected the PE connection.
3. Tighten all screws with 6 Nm.

4.4 Open the connection to the basic interference suppression module for operation on IT system

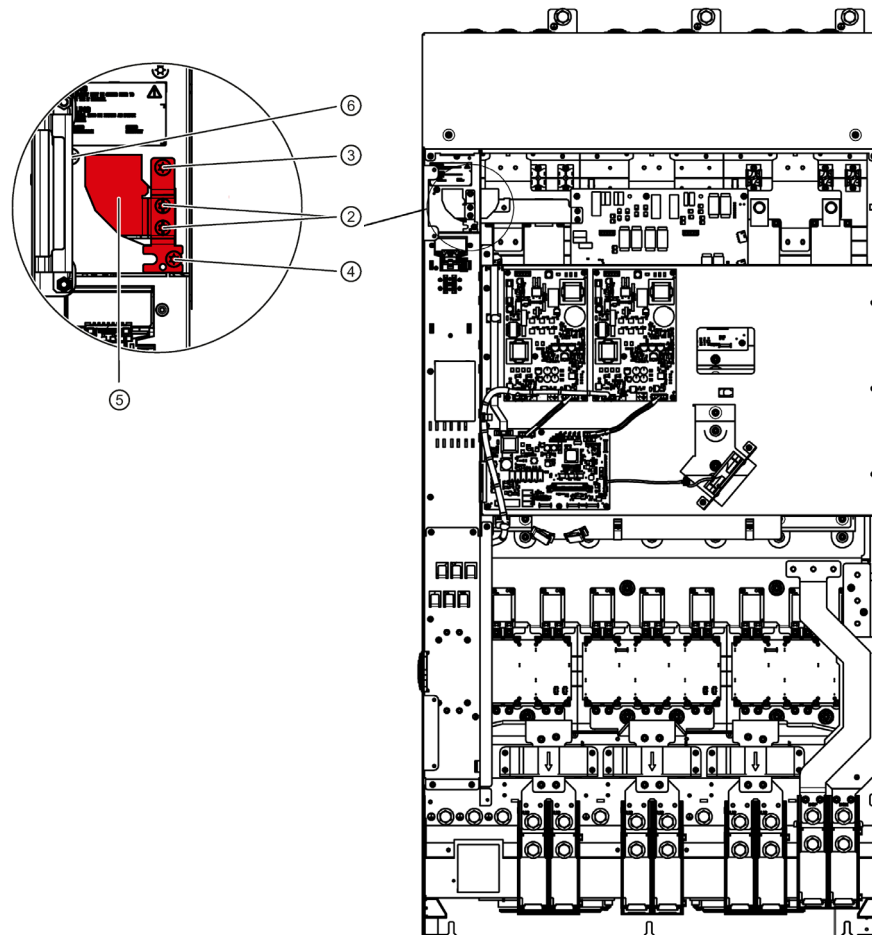

Figure 4-3 Opening the connection to the basic interference suppression module for 690 V power units.

The connection is opened as follows:

1. Remove the front cover.
2. Release the two screws ②; they are captive.
3. Release screws ③, ④ and ⑥, but do not remove the screws.
4. Swivel the connection clip ⑤ around the axis of rotation of screw ③ towards the left, until the connection clip can be fastened using screw ⑥.
5. Tighten the screws ③, ④ and ⑥ with 6 Nm.

4.5 Terminal X9

Terminal strip X9 is used to connect an external 24 V DC power supply and to connect a main or bypass contactor.

Fault and alarm signals can be connected to the digital inputs. The digital output allows, for example, an external rectifier to be controlled.

The external 24 V DC power supply must be connected if the inverter is connected to the line supply via a main contactor (to start the Control Unit).

The power supply should be located directly next to the inverter (e.g. in the same cabinet) and the cable length to terminal X9 should not exceed 5 m.

Note

Inputs are low active.

All signal inputs are low active (wire-break-proof).

Note

If terminals 3 ... 6 are not used

If terminals 3 ... 6 are not used, then you must connect 24 V DC to these. To do this, use an external power supply or terminal 9 on the Control Unit.

The reference potential is connected to terminal X9:2, 7 and terminal 28 on the Control Unit.

Note

Line contactor control

When controlling the main contactor via terminals 11 and 12, separation from the line supply using a control transformer is not required. A 250 V/8 A fuse must be used as protection.

Note

Insulated end sleeves

Insulated end sleeves according to DIN 46228-4 must be used.

Note

Strain relief

For strain relief, the cables to the Control Unit and to the terminal X9 must be fastened to the lugs in the cable duct below terminal X9 (e.g. with cable ties).

If the cables are introduced at the side (at the height of terminal X9), the strain relief must be provided outside the Power Module.

Terminal	Name	Meaning	Input/output	Technical data
1	P24	External power supply	Input	24 V DC (20.1 ... 28.8 V)
2	M	Electronics ground	Reference	Current consumption: max. 2 A
3	External alert	External alarm	Input	Voltage: -3 V ... +30 V
4	External fault	External fault	Input	Current drain: 6.4 mA at 24 V DC
5	Stop 0	Emergency Off, Category 0	Input	1.3 mA at <5 V
6	Stop 1	Emergency Stop category 1	Input	4 mA at >15 V 8 mA at 30 V Level (including ripple): High level: 15 V ... 30 V Low level: -3 V ... +5 V
7	M		Reference	
8	DC link charged	Enable signal "U _{DC link} charged"	Output	Voltage: 24 V DC Max. load current: 500 mA Continuously short-circuit proof The output current is taken from the supply at X9, terminal 1.
9	NC	Not connected		
10	NC	Not connected		
11	Activation line contactor	Line contactor control	Output	Contact type: NO contact Maximum load current: 4 A, 230 V AC, cosφ = 0.6
12	Activation line contactor	Line contactor control	Output	Floating A device to protect against overload and short-circuit is required to supply the unprotected output. Surge suppressors must be connected to the excitation coil of the main contactor (e.g. RC element). To control the main contactor, the following contact characteristic values of the relay can be applied: <ul style="list-style-type: none"> • 250 V AC, 10 A (NC and NO), general purpose, 85 °C, • 24 V DC, 10 A (NC and NO), general purpose, 85 °C, • 30 V DC, 8 A (NO), 6 A (NC), general purpose, 85 °C • B300 (NC and NO), pilot duty, 85 °C • R300 (NC and NO), pilot duty, 85 °C • 24 V AC, 2.0 A (NC and NO), pilot duty, 85 °C
Maximum connection cross section: 2.5 mm ² Minimum connection cross section: 0.2 mm ² Maximum tightening torque: 0.5 Nm (4.5 ... 5 lb.in)				

4.6 EMC compliant connection

4.6.1 Avoiding electromagnetic interference

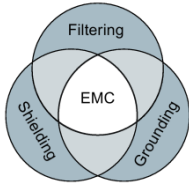

Only the concurrent use of filtering, grounding and shielding ensure an installation in accordance with the EMC requirements.

The next sections cover all of the most important rules for the installation of inverter and drive systems.

4.6.2 EMC-compliant cabinet design

The most cost-effective method of implementing interference suppression measures within the control cabinet is to ensure that interference sources and potentially susceptible equipment are installed separately from each other. This separation must be taken into account already during the planning phase.

EMC zone concept within the control cabinet

The control cabinet has to be divided into EMC zones and the devices within the control cabinet have to be assigned to these zones. The following example explains the zone concept in greater detail.

The zones must be decoupled electromagnetically. This decoupling can, for example, be achieved with large physical separations (approx. 25 cm). Better and space-saving is decoupling using separate metal enclosures or large metal partitions.

Cables within each zone can be unshielded. Cables of different zones must be separated and must not be laid in shared cable harnesses or cable ducts. Where necessary, filters and/or coupler blocks must be deployed at the zone interfaces. Coupler blocks with electrical isolation can effectively prevent the interference propagation between the zones.

All communication and signal cables that exit the control cabinet must be shielded. Additional isolation amplifiers must be used for longer analog signal cables. Sufficient space for connecting the cable shields must be provided, whereby the braided cable shield must be connected to the cabinet ground with excellent electrical conductivity and with a large contact area. Care must be taken to prevent any potential differences regarding the ground potential between the zones. These must be avoided to protect the cable shields from excessively high equalizing currents.

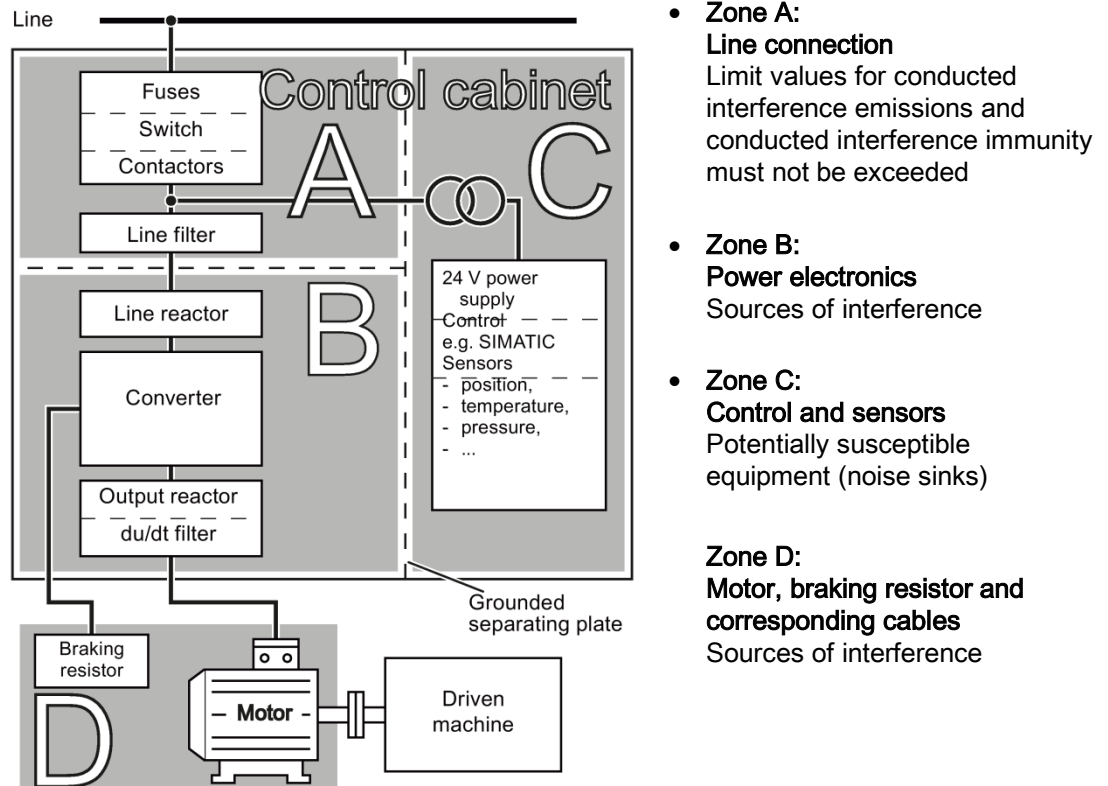

Figure 4-4 Division of the cabinet and the drive system into different EMC zones

4.6.3 Cabinet design

Control cabinet design

- All metallic components of the cabinet (side panels, back walls, roof plates, and floor plates) must be connected to the cabinet frame with excellent electrical conductivity, ideally with a large contact area or by means of several point-like screwed connections (i.e. to create a Faraday cage).
- The cabinet doors must be connected to the cabinet frame with excellent electrical conductivity by means of short, finely stranded, braided grounding strips, which are ideally placed at the top, in the middle, and at the bottom of the doors.

- The PE busbar and EMC shield busbar must be connected to the cabinet frame with excellent electrical conductivity with a large contact area.
- All metallic housings of devices and additional components integrated in the cabinet (such as converter or line filter) must be connected to the cabinet frame with excellent electrical conductivity and with a large contact area. The best option here is to mount devices and additional components on a bare metal mounting plate (back plane) with excellent electrical conductivity. This mounting plate must be connected to the cabinet frame and, in particular, to the PE and EMC shield busbars with excellent electrical conductivity and a large contact area.
- All connections should be made so that they are permanent. Screwed connections on painted or anodized metal components must be made either by means of special contact washers, which penetrate the isolating surface and establish a metallicly conductive contact, or by removing the isolating surface on the contact points.
- Contactor coils, relays, solenoid valves, and motor holding brakes must have interference suppressors to reduce high-frequency radiation when the contacts are opened (RC elements or varistors for AC current-operated coils, and freewheeling diodes for DC current-operated coils). The interference suppressors must be connected directly on each coil.

4.6.4 Cabling

Routing cables inside the cabinet

- All power cables for the drive (line cables, DC link cables, connecting cables between the Braking Module and the associated braking resistor as well as motor cables) must be routed separately from signal and data cables. The minimum distance should be approximately 25 cm. Alternatively, the decoupling can be realized in the control cabinet using metal partitions (separating elements) connected to the mounting plate through a good electrical connection.
- Filtered line cables with a low noise level, i.e. line cables from the line supply to the line filter, must be separately routed away from non-filtered power cables with high noise levels (line cables between the line filter and rectifier, DC link cables, connecting cables between the Braking Module and the associated braking resistor as well as motor cables).
- Signal and data cables, as well as filtered line supply cables, may only cross non-filtered power cables at right angles to minimize coupled-in interference.
- Cables should be kept as short as possible, unnecessary cable lengths must be avoided.
- All cables must be routed as closely as possible to grounded housing components, such as mounting plates or the cabinet frame. This reduces interference radiation as well as coupled-in interference.
- Signal and data cables, as well as their associated equipotential bonding cables, must always be routed in parallel and with the shortest distance possible between them.

- When unshielded single-conductor cables are used within a zone, the feed and return lines must be either routed in parallel with the minimum possible distance between them, or twisted with one another.
- Spare conductors for signal and data cables must be grounded at both ends to create an additional shielding effect.
- Signal and data cables should enter the cabinet only at one point (e.g. from below).
- The shields of the signal cables at the Control Unit must be connected at the Power Module below the mounted Control Unit at the slots provided using the shield connection terminals supplied.
The signal cables are mechanically attached (strain relief) using cable ties, also attached below the mounted Control Unit at the locations provided below the slots for attaching the shield connection terminals.

Cables outside the cabinet

- All power cables (line cables, DC link cables, connecting cables between the Braking Module and the associated braking resistor as well as motor cables) must be routed separately from signal and data cables. The minimum distance should be approximately 25 cm.
- To achieve categories C2 and C3 according to IEC 61800-3, a shielded cable must be used between the inverter and motor, and for higher power ratings a symmetrical, 3-conductor three-phase cable should be used. Shielded cables with symmetrical three-phase conductors (L1, L2, and L3) and an integrated, 3-conductor, and symmetrically arranged PE conductor are ideal for this purpose.
- The shielded cable to the motor must be routed separately from the cables to the motor temperature sensors (PTC/KTY); this is because the cables to the motor temperature sensors should be treated as signal cables.
- Signal and data cables must be shielded to minimize coupled-in interference (capacitive, inductive, and radiated).
- Especially sensitive signal cables - such as setpoint and actual value cables - should be routed without any interruption with optimum shield support at both ends

Cable shields

- Shielded cables must have finely stranded braided shields. Shields that are not as finely braided, such as the concentric conductors used in Protodur NYCWY cables, do not have such an effective shielding effect. Foil shields have a significantly poorer shielding effect and are therefore unsuitable.
- Shields must be connected to the grounded housings at both ends with excellent electrical conductivity and a large contact area. Only when this method is used can coupled-in interference be minimized (capacitive, inductive, radiated).
- Wherever possible, cable shields should be connected directly after they enter the cabinet. The EMC shield bars should be used for power cables; the shield connection options provided in the built-in and cabinet units should be used for signal and data cables.

- Wherever possible, cable shields should not be interrupted by using intermediate terminals.
- In the case of both, the power cables and the signal and data cables, the cable shields should be connected by means of suitable EMC shield clips. The shield clips must connect the shield through a large surface area with low associated inductance to the EMC shield bar or the shield connection option for signal cables.
- Only metal or metallized plug housings should be used for plug-in connections for shielded data cables (e.g. PROFIBUS cables).

4.6.5 Equipotential bonding

Equipotential bonding

- Equipotential bonding within a cabinet element has to be established by means of a suitable mounting plate (back plane), to which all metallic housings of the devices and additional components integrated in the cabinet element (e. g. converter or line filter) are connected. The mounting plate has to be connected to the cabinet frame and to the PE or EMC busbar of the cabinet element with excellent electrical conductivity and a large contact area.
- Equipotential bonding between several cabinet elements has to be established by means of a PE busbar which runs through all the cabinet elements. In addition, the frames of the individual cabinet elements are screwed together several times with good conductivity ensured through the use of contact washers. If extremely long rows of cabinets are installed in two groups back to back, the two PE busbars of the cabinet groups must be connected to each other wherever possible.
- Equipotential bonding within the drive system has to be established by connecting all electrical and mechanical drive components (transformer, cabinet, motor, gearbox, and driven machine) to the grounding system. These connections are established by means of standard PE power cables, which do not need to have any special high-frequency properties. In addition to these connections, the converter (as the source of the high-frequency interference) and all other components in each drive system (motor, gearbox, and driven machine) must be interconnected with respect to the high-frequency point of view. For this purpose cables with good high-frequency properties must be used.

Grounding and high-frequency equipotential bonding measures

The following figure illustrates all grounding and high-frequency equipotential bonding measures using the example of a cabinet with a SINAMICS G120L.

The ground connections represent the conventional grounding system for the drive components.

They are made with standard, PE power conductors without special high-frequency properties and ensure low-frequency equipotential bonding as well as protection against injury.

The connections inside the SINAMICS cabinet provide a good electrical connection for high-frequency currents between the metal housings of the integrated components and the EMC shield busbar of the cabinet. These internal connections can be made over a large area using metal components of the cabinet. In this case, the contact surfaces must be bare metal and each contact point must have a minimum cross-section of several cm². Alternatively, these connections can be made with short, finely stranded, braided copper wires with a larger cross-section ($\geq 95 \text{ mm}^2 / 000 (3/0) (-2) \text{ AWG}$) between the integrated components and the EMC shield busbar.

The shield and the protective ground conductor of the motor cable provide the high-frequency equipotential bonding between the converter and the motor terminal box.

Therefore, connect the protective ground conductor and the cable shield to the motor and to the converter.

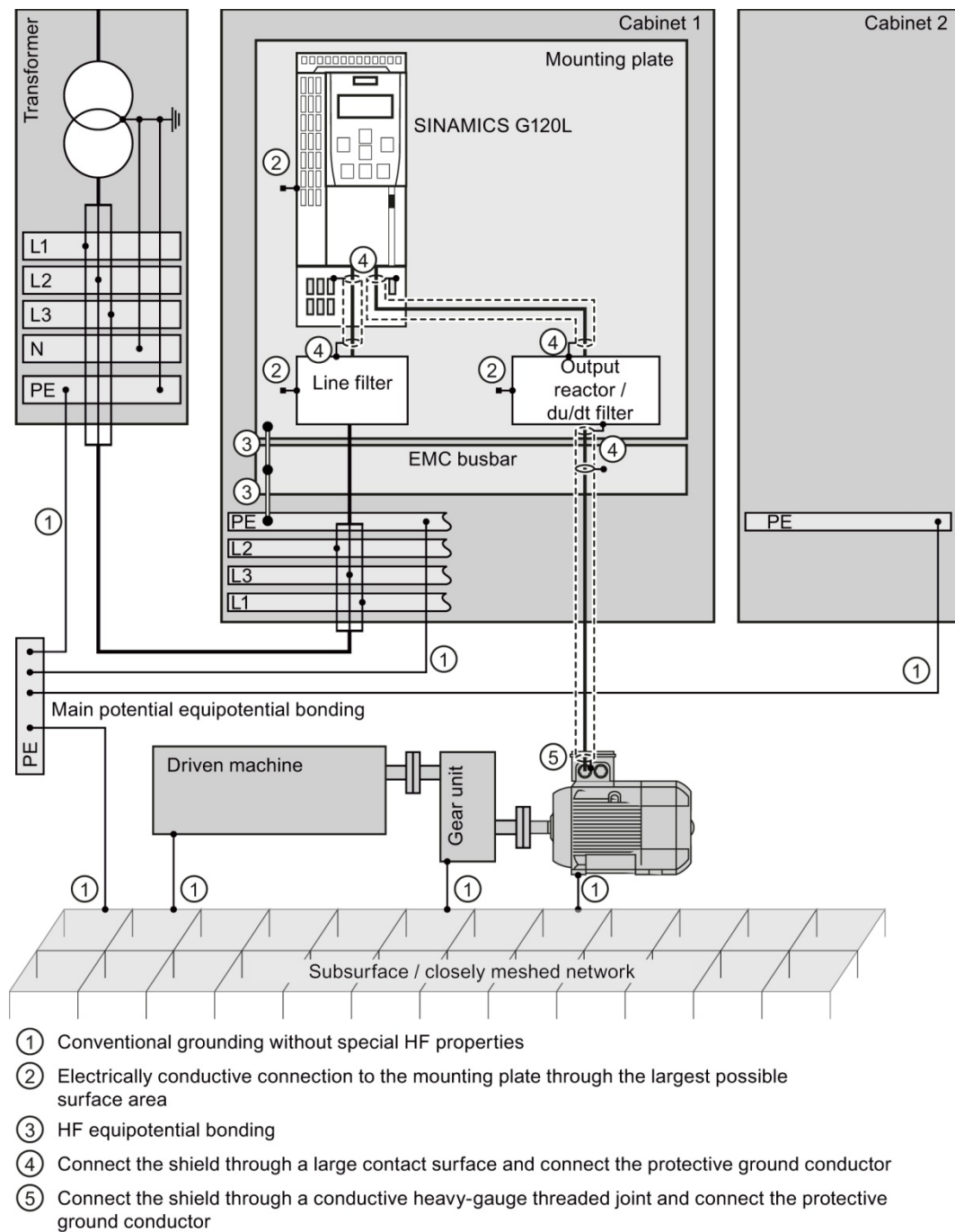

Figure 4-5 Grounding and high-frequency equipotential bonding measures in the drive system and in the plant

Additional measures

Finely stranded, braided copper cables have to be routed in parallel with the cable shields in the following cases:

- Old installations with existing unscreened cables
- Cables with poor high-frequency properties of the shield
- Installations with bad grounding systems

The connections in the diagram below provide a solid, high-frequency bonding between the motor housing, the motor terminal box, the gearbox, the driven machine and the EMC busbar.

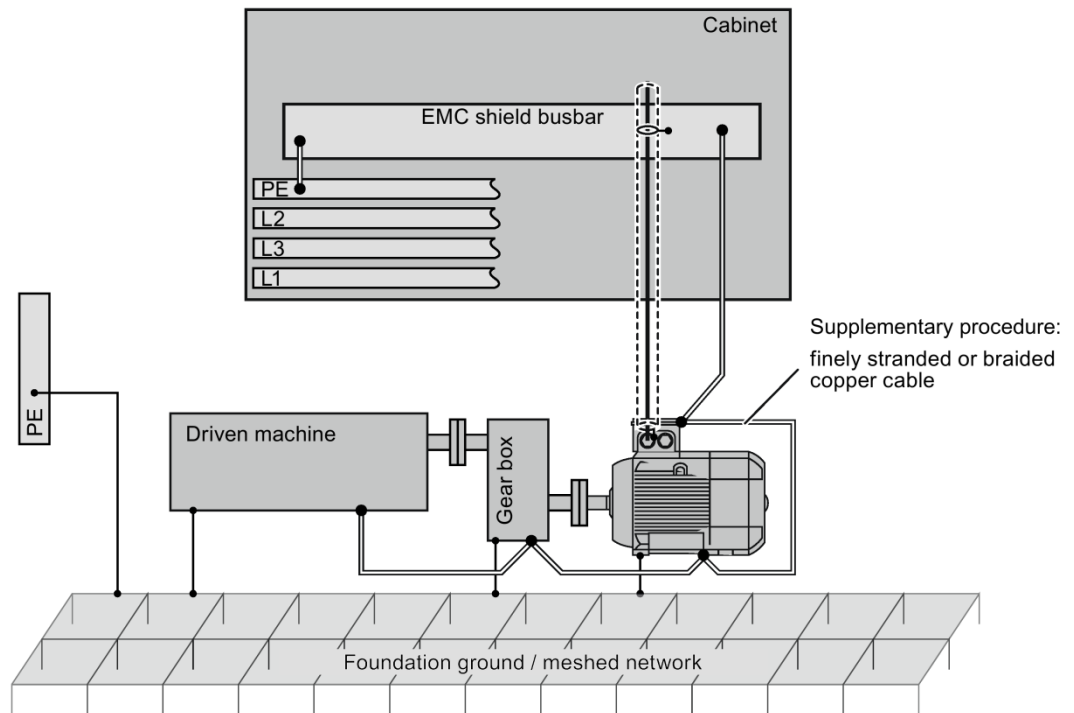

Figure 4-6 Additional high-frequency bonding of the drive system

4.7 Switching on

The converter is switched on in the following steps:

- **Switch on the line voltage**
 - The power supply inside the converter switches on,
 - the DC link is still not precharged.
- **Switch on the converter at the operator panel or with STARTER**
 - By issuing the ON/OFF command (ON button at the BOP-2 / IOP or p0840 = 1 using STARTER).
 - The DC link is now precharged (this takes approx. 4 s).
- **Start the converter**

depending on the parameter assignment, the inverter pulses must be separately enabled - and the converter then accelerates the motor up to the selected speed.

Service and maintenance

5.1 Maintenance

The purpose of maintenance is to preserve the specified condition of the Power Module. Dirt and contamination must be removed regularly and parts subject to wear replaced. The Power Module comprises mostly electronic components. Apart from the fan(s), the unit, therefore, contains hardly any components that are subject to wear or that require maintenance or servicing.

The following points must generally be observed.

Dust deposits

Dust deposits inside the Power Module must be removed at regular intervals by qualified personnel in line with the relevant safety regulations. The unit must be cleaned using a brush and vacuum cleaner, and dry compressed air (max. 1 bar) for areas that cannot be easily reached.

Ventilation

Make sure that the cabinet ventilation slots are not obstructed. The fan must be checked to make sure that it is functioning correctly.

If dirt filters are used, the specified replacement intervals must be observed.

Cables and screw terminals

Cables and screw terminals must be checked regularly to ensure that they are secure, and if necessary, retightened. Retighten if necessary. The wiring must be checked for damage. Defective parts must be replaced immediately.

Note

The actual maintenance intervals depend on the installation and operating conditions.

Siemens offers its customers support in the form of service contracts. For further information, contact your Siemens regional office or sales office.

Safety instructions for maintenance and repair work

 **WARNING**

Danger to life if the fundamental safety instructions and remaining risks are not carefully observed

The non-observance of the fundamental safety instructions and residual risks stated in Chapter Basic safety instructions (Page 7) can result in accidents with severe injuries or death.

- Adhere to the fundamental safety instructions.
- When assessing the risk, take into account residual risks.



 **DANGER**

Danger to life through electric shock due to the residual charge of the DC link capacitors

Because of the DC link capacitors, a hazardous voltage is present for up to five minutes after the power supply has been switched off.

Contact with live parts can result in death or serious injury.

- Only open the device after five minutes have elapsed.
- Measure the voltage before starting work on the DCP and DCN DC link terminals.

5.2 Forming

Forming the DC link capacitors

If inverters are not operational for more than one year, then the DC link capacitors must be formed. The date of manufacture and therefore the storage time can be determined based on the Power Module serial number. You can take the details about the measures required when forming from the following diagram.

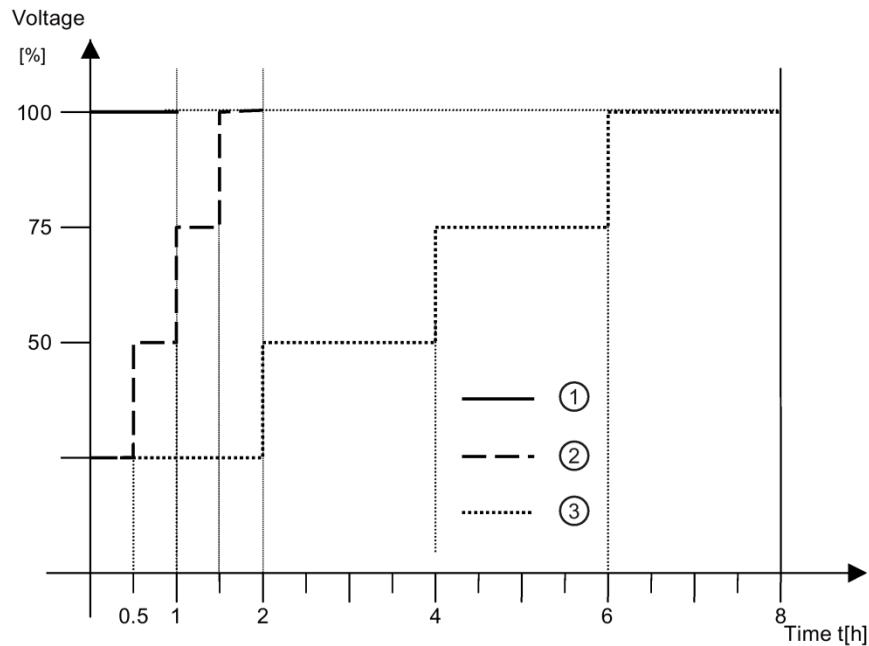

Storage times less than 1 year: No measures required

- ① Storage times of between 1 and 2 years: Connect voltage for one hour before switching on
- ② Storage times of between 2 and 3 years: Form corresponding to the curve before switching on
- ③ Storage times of 3 and more years: Form corresponding to the curve before switching on

Figure 5-1 Measures when forming the DC link capacitors

Code to encrypt the date of manufacture

The date of manufacture is encrypted in positions 3 - 6 of the serial number.

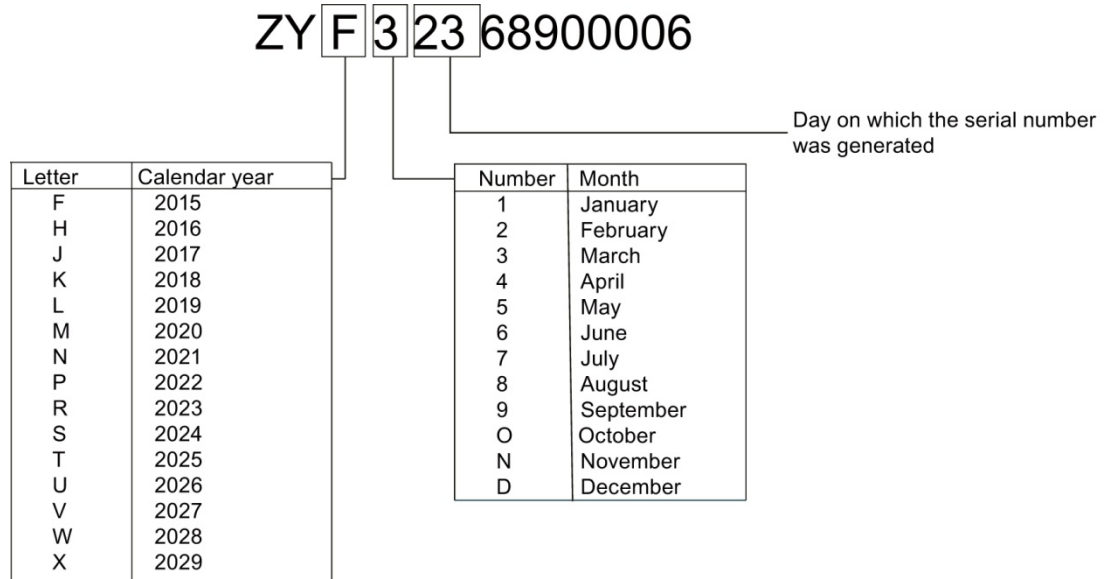

Figure 5-2 Code to encrypt the date of manufacture

In this example, the date of manufacture is March 23, 2015

5.3 Replacing the cooling fan

Service life of the fan

The average service life of the fan is 40,000 hours. In practice, however, the service life may deviate from this value. Especially a dusty environment can block up the fan.

The fan must be replaced in good time in order to ensure that the drive remains ready for operation.

Note

Operating hours counter for the fan

The number of total operating hours are indicated in parameter p0251; alarm A30042 is output 500 hours before reaching and when reaching the end of the service life.

Fan replacement for frame size HX@380 V

Preparatory Steps:

- Disconnect the converter from power supply

Removal

The steps for the removal procedure are numbered in accordance with Figure 5-3 Fan removal for frame size HX@380 V, view from front and Figure 5-4 Fan removal for frame size HX@380 V, view from below

1. Release two retaining screws (①) and remove the front cover of power unit;
2. Disconnect the two cable lugs (②) of fan power supply;
3. Release four retaining screws (③) and draw out the fan assembly units;
4. Release four retaining screws (④) for every fan and remove the cooling fan out from the fan assembly unit.

Installation

For re-installation, carry out the above steps in reverse order.

Tightening torque for the fixing screws: 3 Nm.

NOTICE
Damage to the cooling fan due to wrong cable connection
The signal connection of new replaced fan must be same as the original wiring; otherwise the fan would be damaged.

Note

The fixing screw of cooling fan must be locked

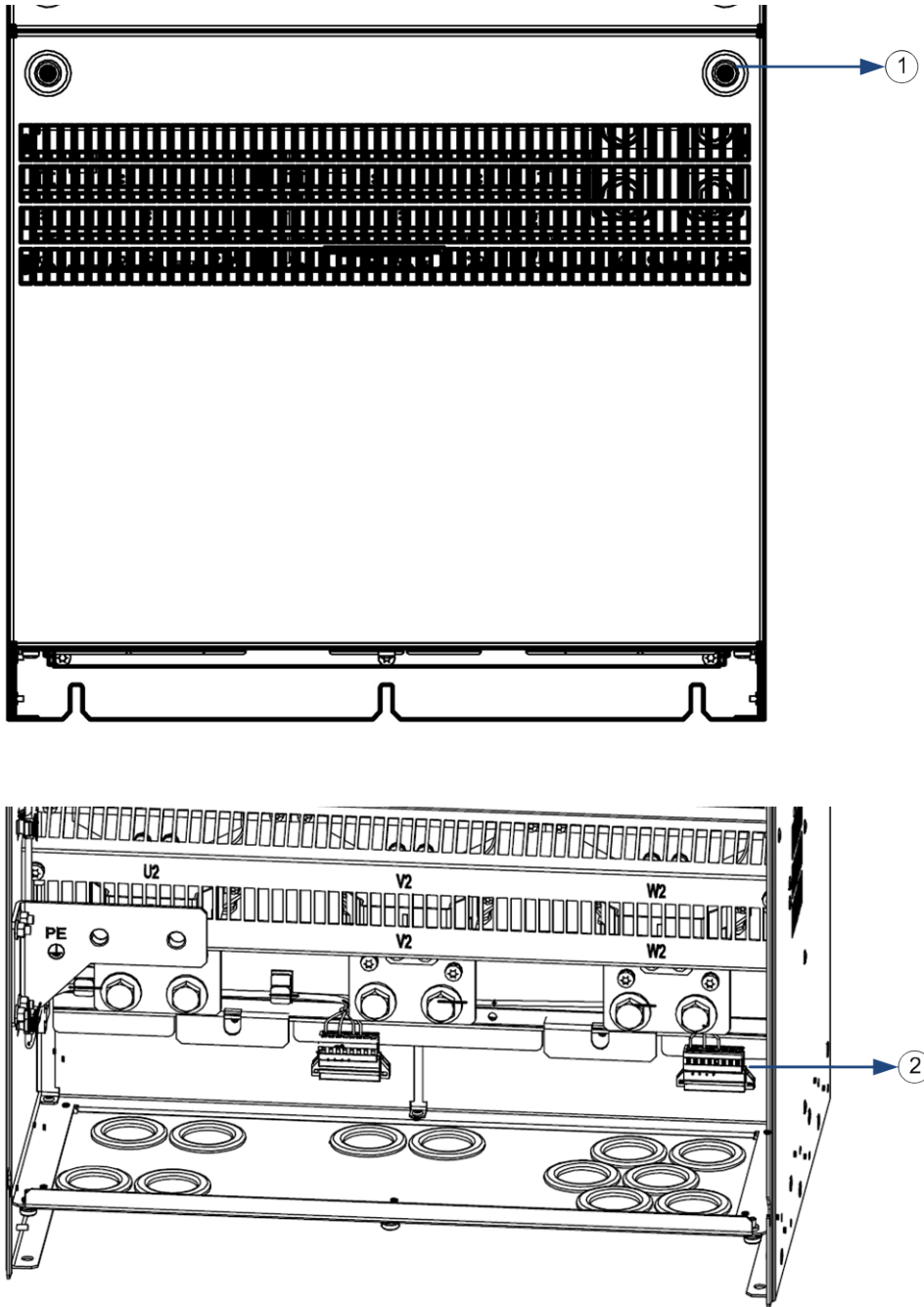

Figure 5-3 Fan removal for frame size HX@380 V, view from front

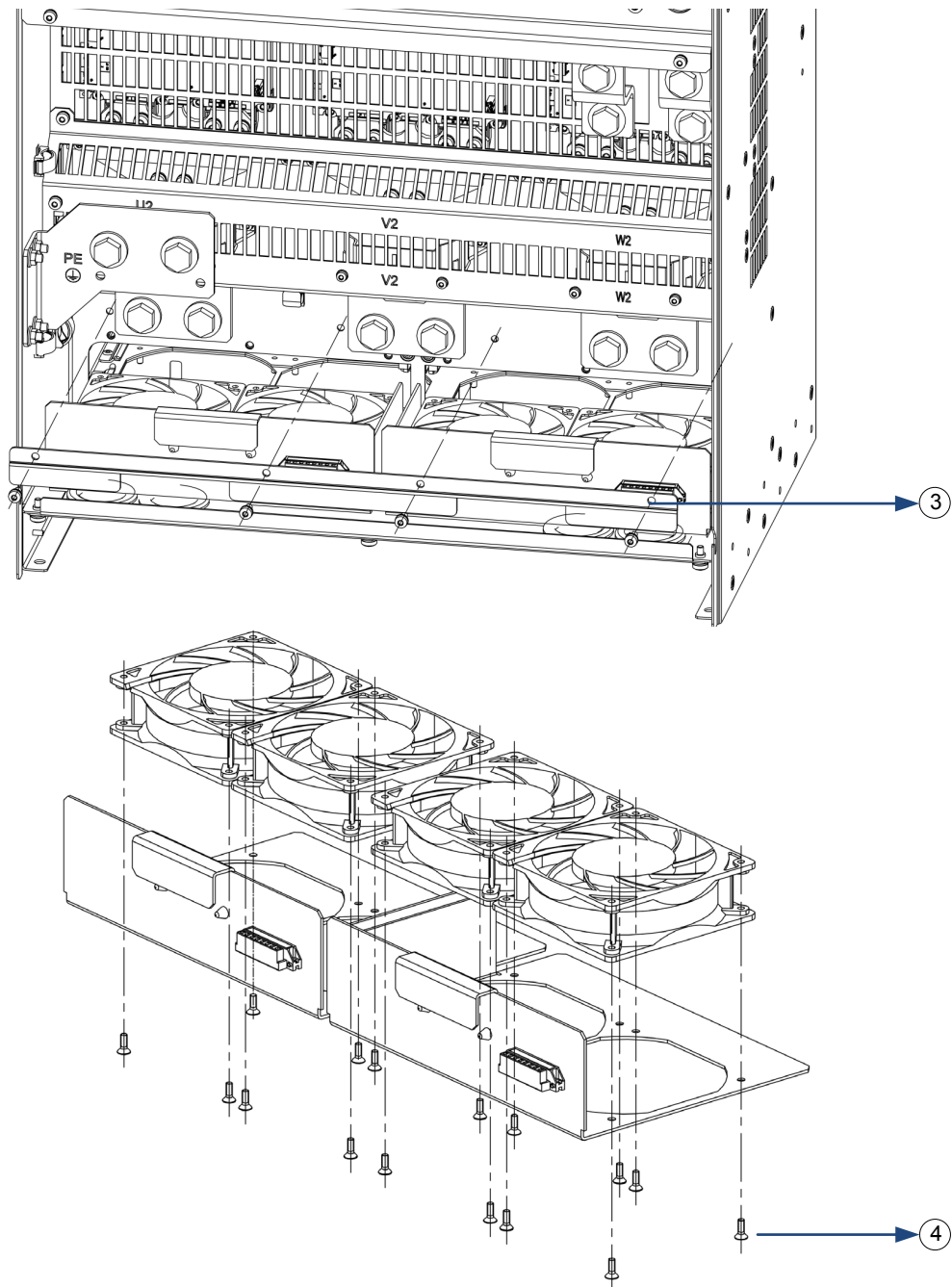

Figure 5-4 Fan removal for frame size HX@380 V, view from below

Note

There is an arrow symbol on the fan for indicating the airflow direction. When installing, the arrow must be directed to top.

Fan replacement for frame size JX@380 V

Preparatory Steps:

- Disconnect the converter from power supply

Removal

The steps for the removal procedure are numbered in accordance with Figure 5-5 Fan removal for frame size JX@380 V, view from front and Figure 5-6 Fan removal for frame size JX@380 V, view from below.

1. Release three retaining screws (①) and remove the front cover of power unit;
2. Disconnect the two cable lugs (②) of fan power supply;
3. Release eight retaining screws (③) and draw out the fan assembly units;
4. Release four retaining screws (④) for every fan and remove the cooling fan out from the fan assembly unit.

Installation

For re-installation, carry out the above steps in reverse order.

Tightening torque for the fixing screws: 3 Nm.

NOTICE
Damage to the cooling fan due to wrong cable connection
The signal connection of new replaced fan must be same as the original wiring; otherwise the fan would be damaged.

Note

The fixing screw of cooling fan must be locked

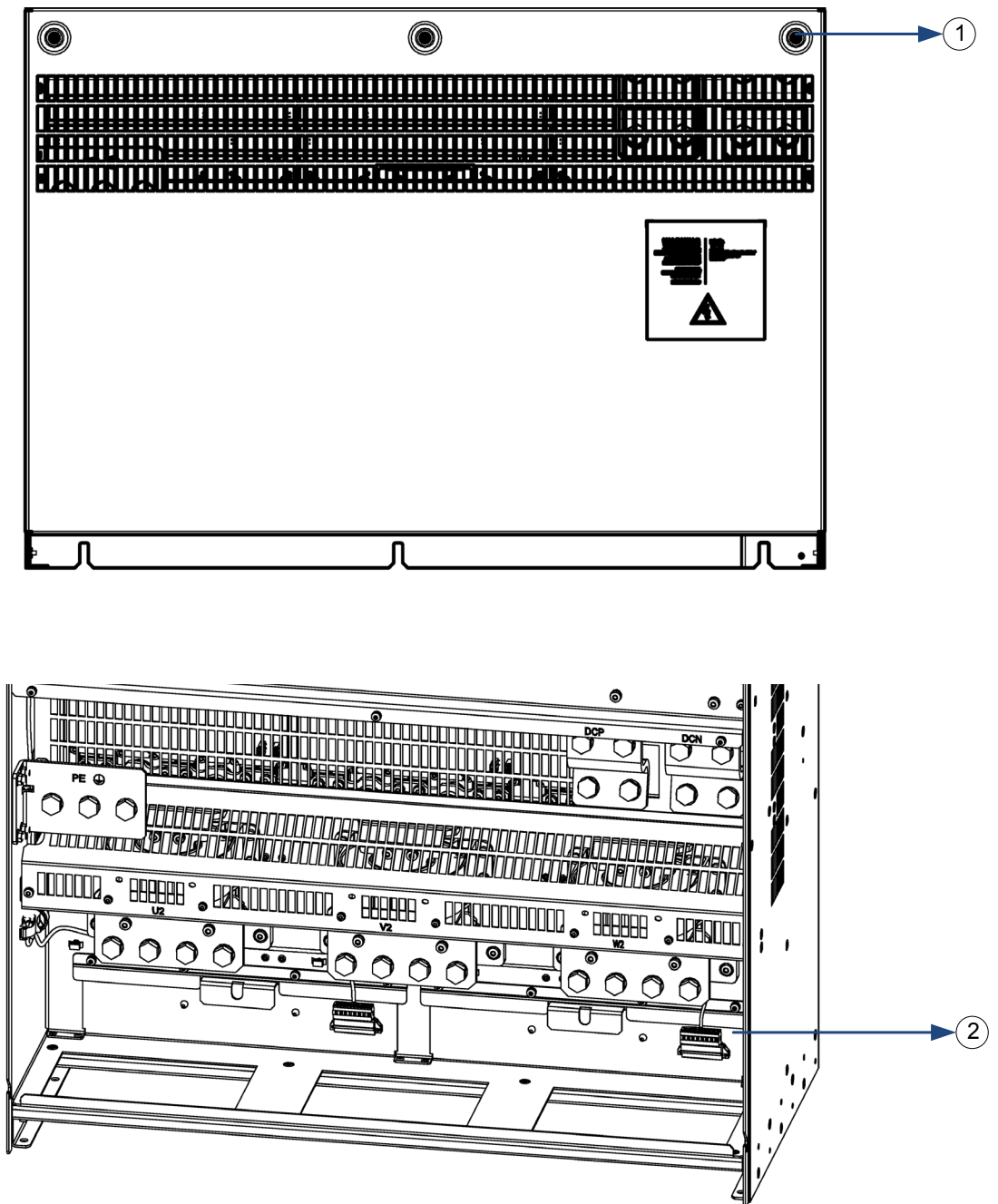

Figure 5-5 Fan removal for frame size JX@380 V, view from front

5.3 Replacing the cooling fan

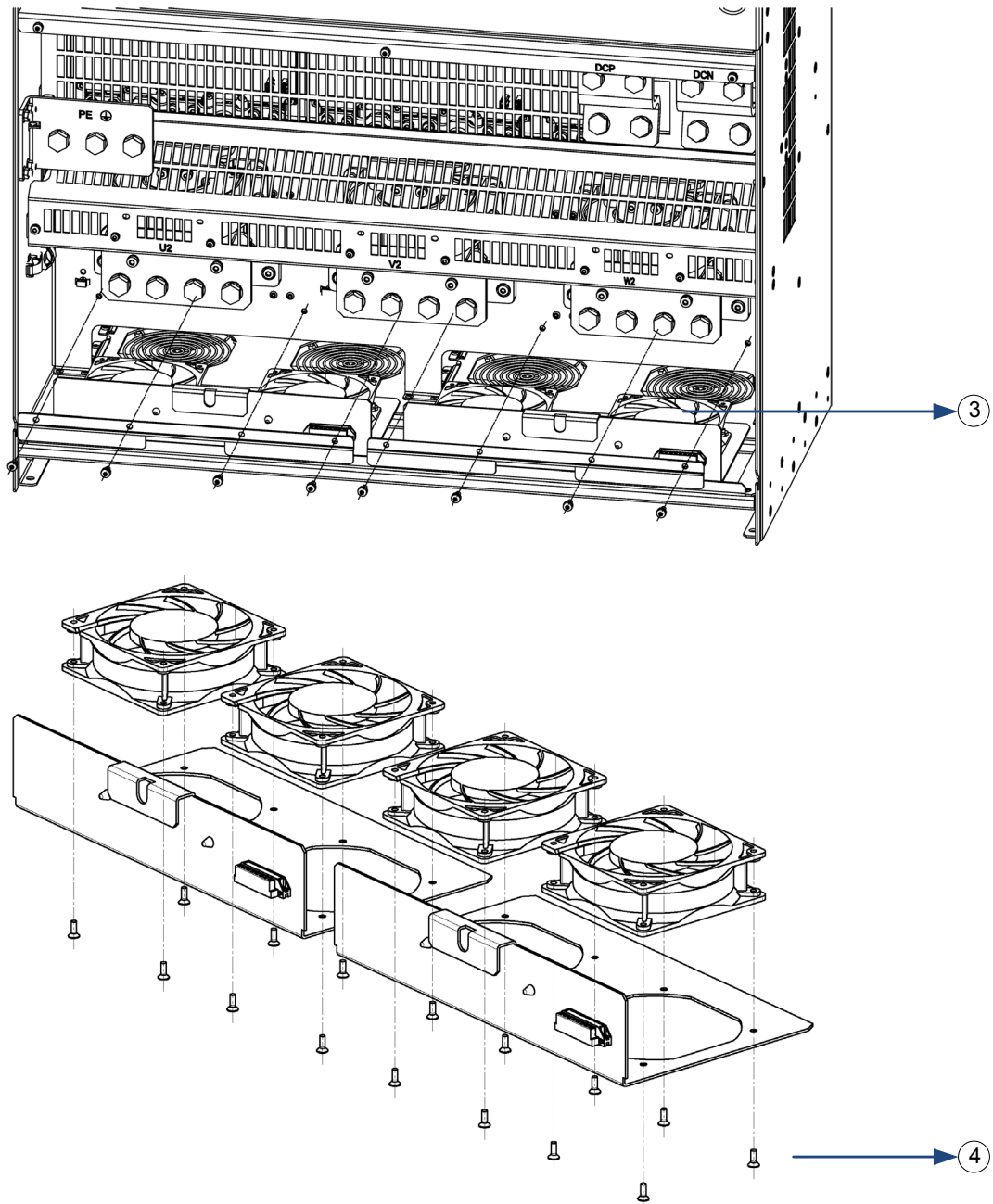

Figure 5-6 Fan removal for frame size JX@380 V, view from below

Note

There is an arrow symbol on the fan for indicating the airflow direction. When installing, the arrow must be directed to top.

Wiring of new replaced fan for frame size HX@380 V and JX@380 V

The signal connection of new replaced fan must be same as the original wiring, refer to Figure 5-7.

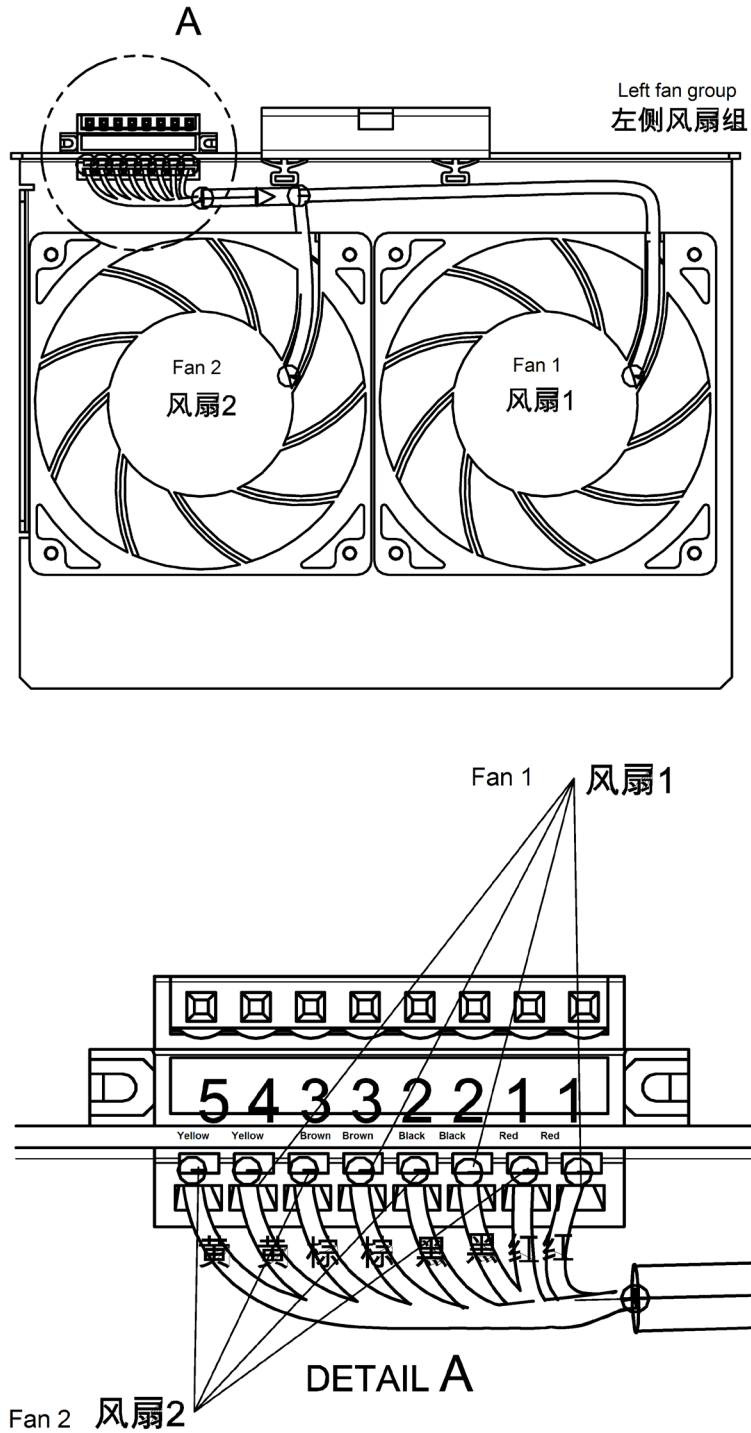

Figure 5-7 Wiring of cooling fan

Fan replacement for frame size HX and JX@690 V

Removal

1. Switch the converter off.
2. Remove the fixing screws from the left fan (①). The screws are captive.
3. Shift the fan unit to the right, from position "2" to position "1" (this is marked on the housing).
The connector is simultaneously released.
4. Remove the fan unit from the inverter (②).
5. Remove the fixing screws from the right fan (③). The screws are captive.
6. Shift the fan unit to the left, from position "2" to position "1" (this is marked on the housing).
The connector is released at the same time.
7. Remove the fan unit from the inverter (④).

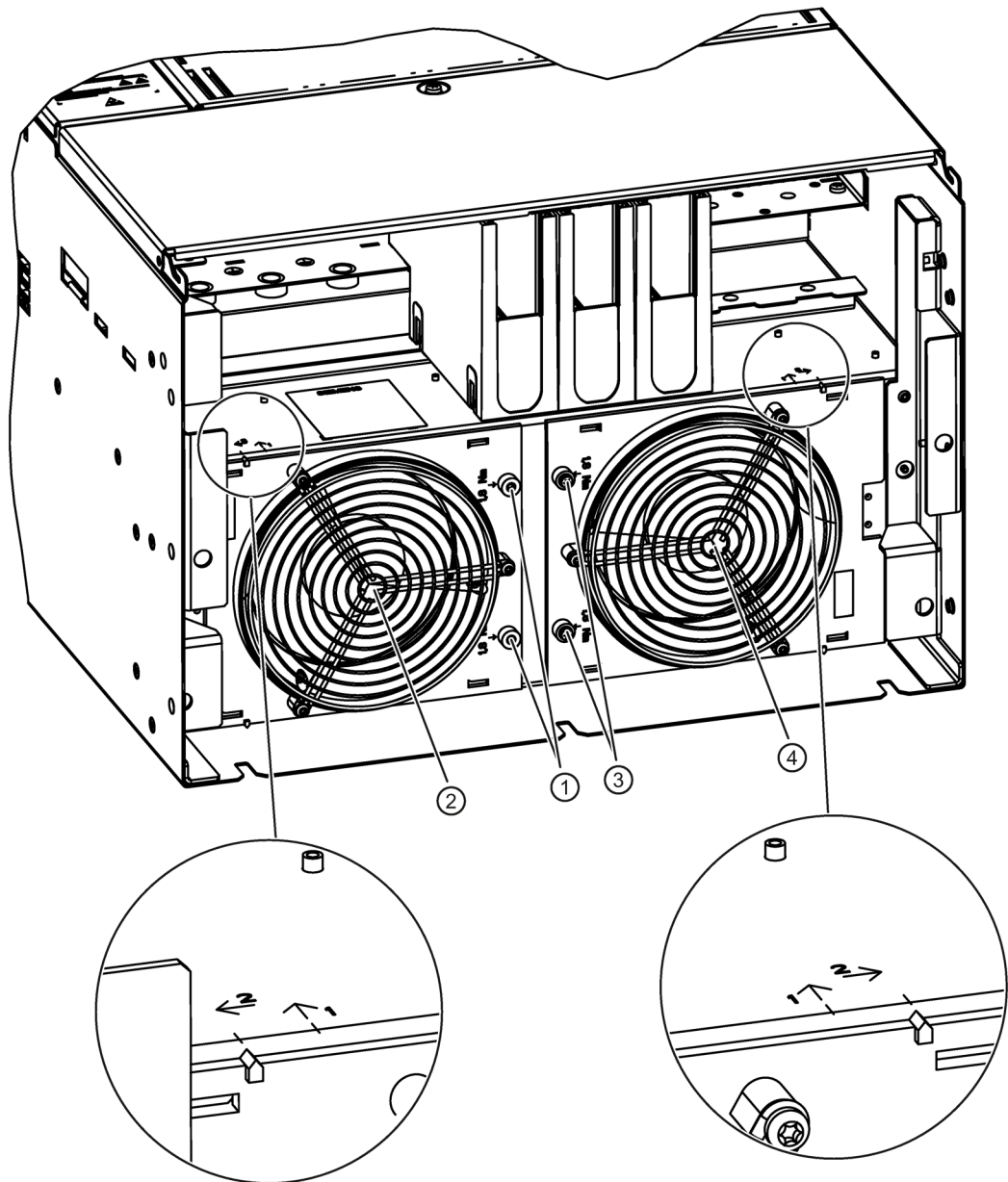

Figure 5-8 Fan removal for frame size HX@690 V, view from below (view is similar to frame size JX)

Installation

For re-installation, carry out the above steps in reverse order.

Tightening torque for the captive fixing screws: 1.8 Nm

Technical specifications

6.1 General technical data

Table 6- 1 General technical data

Electrical data			
Line system configurations	Grounded TN/TT systems and non-grounded IT systems		
Line requirement	A line reactor (2 % u_k) must be connected in series if $R_{sc} > 33$		
Line voltage	380 V (-15 %) ... 440 V (+10 %) 500 V (-10 %) ... 690 V (+10 %)		
Line frequency	47 ... 63 Hz		
Output frequency	0 ... 100 Hz		
Displacement factor $\cos \varphi$ power factor λ	0.96 0.75 ... 0.93 (with line reactor $u_k = 2$ %)		
Inverter efficiency	> 98 %		
Short-circuit current rating per IEC, in conjunction with the specified fuses	280 ... 560 kW @380 V: 65 kA 280...630 kW @690 V: 100 kA		
Overvoltage category	III according to IEC 61800-5-1		
Mechanical data			
Degree of protection	IP20 (frame size HX@380 V and JX@690 V), IP00(frame size JX@380 V)		
Protection class	according to IEC 61800-5-1: Class I (with protective conductor system) and Class III (PELV)		
Cooling method	Forced air cooling AF according to IEC 60146		
Sound pressure level L_{PA} (1 ma)	280 ... 560 kW @380 V: ≤ 76 dB(A) ¹⁾ 500 ... 630 kW @690 V: ≤ 74 dB(A) ¹⁾		
Touch protection	according to IEC 61800-5-1: For the intended purpose		
Compliance with standards			
Standards	IEC 60146-1-1, IEC 61800-2, IEC 61800-3, IEC 61800-5-1, IEC 60204-1, IEC 60529		
CE marking	To EMC directive No. 2014/30/EC and low-voltage directive No. 2014/35/EC		
Radio interference suppression	In accordance with the EMC product standard for variable-speed drives IEC 61800-3, "second environment" ²⁾ . Application in "first environment" possible with line filters.		
Approval	CE		
Ambient conditions	During storage ³⁾	During transport ³⁾	During operation
Ambient temperature	-25 ... +55° C	-25 ... +70° C above -40° C for 24 hours	0 ... +40° C up to +50° C with derating
Relative humidity (no condensation) Corresponds to class	5 to 95% 1K4 according to IEC 60721-3-1	5 ... 95% at 40° C 2K3 according to IEC 60721-3-2	5 ... 95 % 3K3 according to IEC 60721-3-3
Environmental class / harmful chemical substances	1C2 according to IEC 60721-3-1	2C2 according to IEC 60721-3-2	3C2 according to IEC 60721-3-3

6.1 General technical data

Organic/biological influences	1B1 according to IEC 60721-3-1	2B1 according to IEC 60721-3-2	3B1 according to IEC 60721-3-3
Pollution degree	2 according to IEC 61800-5-1		
Installation altitude	Up to 1000 m above sea level without derating, > 1000 m above sea level with derating (see "Derating data")		
Mechanical strength	During storage ³⁾	During transport ³⁾	During operation
Vibrational load	F _h test according to IEC60068-2-64 30min/axis, 3 axes 10~200Hz ASD 1.0(m ² /s ³)	F _h test according to IEC 60068-2-64 30min/axis, 3 axes 10~200Hz ASD 1.0(m ² /s ³)	F _c test according to IEC 60068-2-6 0.075mm for 10~58Hz, 1g for >58~150Hz
Shock load		Test according to IEC 60068-2-27 100 m/s ² (10 x g)/11 ms	Test according to IEC 60068-2-27 100 m/s ² (10 x g)/11 ms

Deviations from the defined classes are shown in *italics*.

- 1) maximum sound pressure level, ascertained in the IP20 cabinet
- 2) Standard construction: Devices installed in the switch cabinet with EMC-conform construction, line reactor uk = 2%, shielded motor cable (e.g. Prototflex EMC) with max. 100 m cable length, line perturbations according to IEC 61000-2-4: Class 2, THD(U) total = 8 % for typical line conditions (R_{sc} > 30 ... 50); THD(I) total: typically 30 ... 45 % (15 < R_{sc} < 50)
- 3) in transport packaging

See also

Derating factor of the output current as a function of the operating temperature (Page 97)

Derating as a function of the installation altitude (Page 97)

Derating factor of the output current as a function of the line voltage (Page 99)

Electromagnetic compatibility (Page 102)

Operating ranges

The inverter can only be operated with reduced output current at low output frequencies. The connection is shown in the following diagram.

The diagram clearly demarcates continuous duty ranges from short-time duty ranges.

The operating ranges are used to ensure that the inverter operates reliably at all times, including in particular in relation to lifetime expectancy.

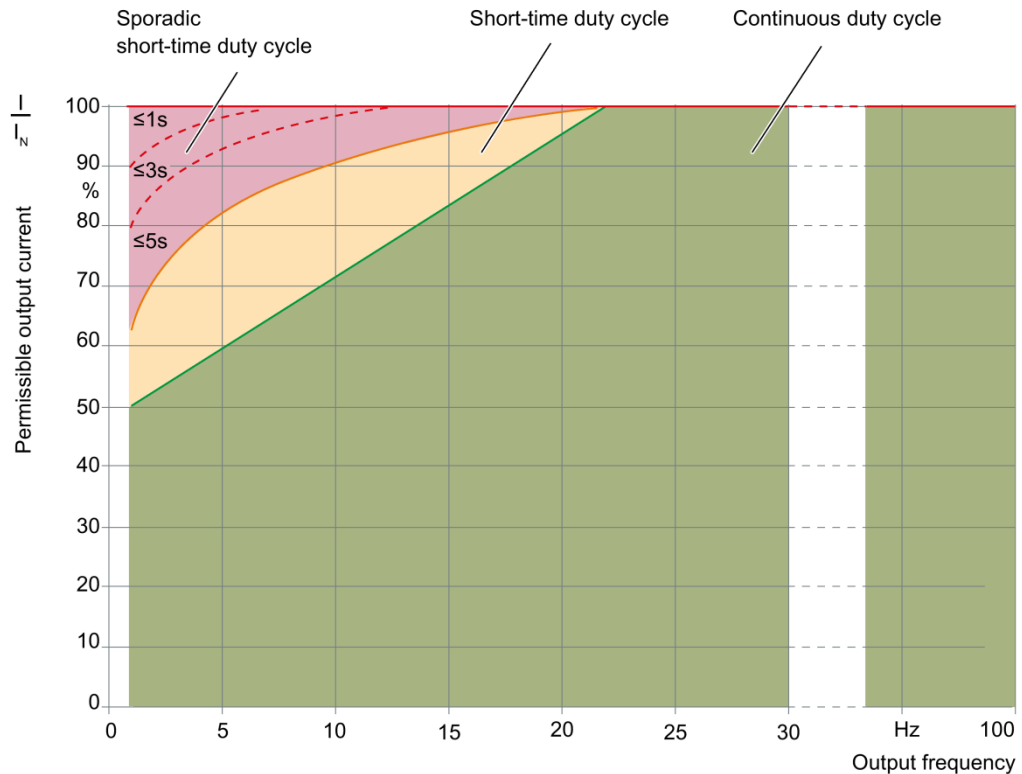

Figure 6-1 Operating ranges

Explanation of the operating ranges:

- Continuous duty** (green range in the diagram)
 Continuous duty is permitted in this range without restriction.
- Short-time duty** (yellow range in the diagram)
 Operation in this range is possible for a total 2% of the total operating duration with no notable limitation in the inverter's lifetime. There is no overload reaction through the thermal monitoring model.
- Sporadic short-time duty cycle** (red range in the diagram)
 Operation in this range is possible only for very short and rare operational states less than 0.1 % of the total operating duration with no notable limitation in the inverter's lifetime. There is no overload reaction through the thermal monitoring model if the times stated in the diagram are complied with.

Permissible inverter overload

The inverters have different load capabilities, "High Overload" and "Low Overload", depending on the expected.

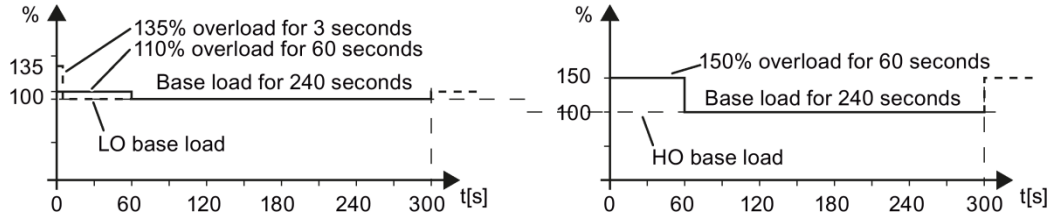

Figure 6-2 Load cycles, "Low Overload" and "High Overload"

Note

Please note the base load (100 % power or current) for Low Overload is higher than the base load for High Overload.

Definitions

- **LO base-load input current** 100 % of the permissible input current with a load cycle according to Low Overload.
- **LO base-load output current** 100 % of the permissible output current with a load cycle according to Low Overload.
- **LO base-load power** Power with LO base-load output current
- **HO base-load input current** 100 % of the permissible input current with a load cycle according to High Overload.
- **HO base-load output current** 100 % of the permissible output current with a load cycle according to High Overload.
- **HO base-load power** Power with HO base-load output current
- **Rated current I_N** Continuous current at the type rating, overload not possible

6.2 Specific technical data

Note

Recommended connection cross-sections

The recommended connection cross-sections are determined for copper cables at 40° C (104° F) ambient temperature and cables with a permitted operating temperature on the conductor for 70° C (laying type C - factor for bundling 0.75 considered) according to DIN VDE 0298-4/08.03).

Protective conductor cross-section (S: Cross-section of the supply connection phase conductor, MS: Cross-section of the external protective conductor):

Minimum cross-sections:

- $S \leq 16 \text{ mm}^2 \rightarrow MS = S$
- $16 \text{ mm}^2 \leq S \leq 35 \text{ mm}^2 \rightarrow MS = 16 \text{ mm}^2$
- $S > 35 \text{ mm}^2 \rightarrow MS = 0.5 \times S$

Recommended cross-sections:

- $MS \geq S$
-

PM330L frame size HX, 3-ph. 380 VAC... 440 VAC

Table 6-2 PM330L, frame size HX, 3 AC 380 V ... 440 V

Order no.	6SL3310...	...1CE35-2AA0	...1CE35-8AA0	...1CE36-6AA0	...1CE37-4AA0
Rated input current					
- for 380 V, 40° C		546 A	617 A	684 A	760 A
- for 440 V, 40° C		501 A	548 A	603 A	683 A
- for 380 V, 50° C		464 A	524 A	582 A	651 A
- for 440 V, 50° C		426 A	465 A	512 A	581 A
Rated output current I_N					
- for 380 V, 40° C		535 A	605 A	670 A	750 A
- for 440 V, 40° C		491 A	537 A	591 A	669 A
- for 380 V, 50° C		455 A	514 A	570 A	638 A
- for 440 V, 50° C		417 A	456 A	502 A	569 A
LO base-load power					
LO base-load power		280 kW	315 kW	355 kW	400 kW
LO base-load input current at 380 V		536 A	602 A	658 A	740 A
LO base-load output current at 380 V		525 A	590 A	645 A	725 A
HO base-load power					
HO base-load power		200 kW	250 kW	250 kW	315 kW
HO base-load input current at 380 V		437 A	480 A	505 A	566 A
HO base-load output current at 380 V		428 A	470 A	495 A	555 A
Fuse according to IEC manufacturer:					
		3NE1436-2 (630 A/690 V)	3NE1437-2 (710 A/690 V)	3NE1438-2 (800 A/690 V)	3NE1448-2 (850 A/690 V)
Maximum permissible line short-circuit current I_{kmax}					
		Siemens AG	Siemens AG	Siemens AG	Siemens AG
		≤ 100 kA	≤ 100 kA	≤ 100 kA	≤ 100 kA
Minimum network short-circuit current required I_{kmin}¹⁾					
		> 8.0 kA	> 9.0 kA	> 10.0 kA	> 12.0 kA
max.power loss, at I_N, 40 °C, 380 V					
		5.408 kW	6.395 kW	7.291 kW	7.989 kW
Required cooling air flow					
		345 l/s	345 l/s	345 l/s	345 l/s
Maximum connectable cross-section of the line, motor and DC-link cable					
		2 x 240 mm ² 2 x 500 kcmil	2 x 240 mm ² 2 x 500 kcmil	2 x 240 mm ² 2 x 500 kcmil	2 x 240 mm ² 2 x 500 kcmil
Recommended cable cross-section / 380 V					
- power cable		2 x 240 mm ²	2 x 240 mm ²	2 x 240 mm ²	2 x 240 mm ²
- motor cable		2 x 185 mm ²	2 x 185 mm ²	2 x 240 mm ²	2 x 240 mm ²
Recommended cable cross-section / 440 V					
- power cable		2 x 185 mm ²	2 x 185 mm ²	2 x 240 mm ²	2 x 240 mm ²
- motor cable		2 x 150 mm ²	2 x 150 mm ²	2 x 185 mm ²	2 x 240 mm ²
Tightening torque for line, motor and ground cable					
		50 Nm / 443 lbf in	50 Nm / 443 lbf in	50 Nm / 443 lbf in	50 Nm / 443 lbf in
Weight					
		155 kg	155 kg	157 kg	160 kg
Dimension (width x height x depth)					
		548 mm x 1487.5 mm x 410 mm			
Minimum control cabinet size for installation of the Power Module (width x height x depth)					
		800 mm x 2000 mm x 600 mm			

1) The network supply must be capable of supplying the minimum short-circuit current so that the fuses trigger and consequential damage is avoided.

Note: If the minimum short-circuit current is not reached then the tripping time for the fuses increases, and this may result in consequential damage.

PM330L frame size JX, 3-ph. 380 VAC... 440 VAC

Table 6- 3 PM330L, frame size JX, 3 AC 380 V ... 440 V

Order no.	6SL3310...	...1CE38-3AA0	...1CE38-8AA0	...1CE41-0AA0
Rated input current				
- for 380 V, 40° C		870 A	959 A	1060 A
- for 440 V, 40° C		755 A	825 A	939 A
- for 380 V, 50° C		740 A	816 A	912 A
- for 440 V, 50° C		642 A	701 A	798 A
Rated output current I _N				
- for 380 V, 40° C		840 A	925 A	1035 A
- for 440 V, 40° C		729 A	794 A	906 A
- for 380 V, 50° C		714 A	786 A	880 A
- for 440 V, 50° C		620 A	675 A	770 A
LO base-load power		450 kW	500 kW	560 kW
LO base-load input current at 380 V		849 A	929 A	1055 A
LO base-load output current at 380 V		820 A	895 A	1015 A
HO base-load power		355 kW	400 kW	450 kW
HO base-load input current at 380 V		696 A	756 A	828 A
HO base-load output current at 380 V		672 A	728 A	797 A
Fuse according to IEC manufacturer:		2 x 3NE1334-2 (2 x 500 A/690 V) Siemens AG	2 x 3NE1435-2 (2 x 560 A/690 V) Siemens AG	2 x 3NE1436-2 (2 x 630 A/690 V) Siemens AG
Maximum permissible line short-circuit current I _{kmax}		≤ 100 kA	≤ 100 kA	≤ 100 kA
Minimum network short-circuit current required I _{kmin} ¹⁾		> 8.6 kA	> 14.0 kA	> 17.0 kA
max.power loss, at I _N , 40 °C, 380 V		9 kW	10 kW	11.2 kW
Required cooling air flow		345 l/s	345 l/s	345 l/s
Maximum connectable cross-section of the line, motor and DC-link cable		4 x 240 mm ² 4 x 500 kcmil	4 x 240 mm ² 4 x 500 kcmil	4 x 240 mm ² 4 x 500 kcmil
Recommended cable cross-section / 380 V				
- power cable		4 x 185 mm ²	4 x 185 mm ²	4 x 240 mm ²
- motor cable		4 x 150 mm ²	4 x 185 mm ²	4 x 240 mm ²
Recommended cable cross-section / 440 V				
- power cable		4 x 120 mm ²	4 x 150 mm ²	4 x 185 mm ²
- motor cable		4 x 120 mm ²	4 x 150 mm ²	4 x 185 mm ²
Tightening torque for line, motor and ground cable		50 Nm / 443 lbf in	50 Nm / 443 lbf in	50 Nm / 443 lbf in
Weight		222 kg	228 kg	236 kg
Dimension (width x height x depth)			801 x 1438 x 410	
Minimum control cabinet size for installation of the Power Module (width x height x depth)			1000 x 2000 x 600	

- ¹⁾ The network supply must be capable of supplying the minimum short-circuit current so that the fuses trigger and consequential damage is avoided.
Note: If the minimum short-circuit current is not reached then the tripping time for the fuses increases, and this may result in consequential damage.

6.2 Specific technical data

Table 6- 4 PM330L, frame size HX, 3 AC 500 V ... 690 V, Part I

Article No.	6SL3310...	...1CG33-0AA0	...1CG33-4AA0	...1CG33-8AA0
Rated input current				
- at 500 V, 40 °C		339 A	383 A	416 A
- at 600 V, 40 °C		324 A	367 A	412 A
- at 690 V, 40 °C		314 A	354 A	409 A
- at 500 V, 50 °C		290 A	328 A	356 A
- at 600 V, 50 °C		277 A	314 A	353 A
- at 690 V, 50 °C		269 A	303 A	350 A
Rated output current I _N				
- at 500 V, 40 °C		324 A	368 A	400 A
- at 600 V, 40 °C		310 A	353 A	396 A
- at 690 V, 40 °C		300 A	340 A	393 A
- at 500 V, 50 °C		275 A	313 A	340 A
- at 600 V, 50 °C		263 A	300 A	337 A
- at 690 V, 50 °C		255 A	289 A	334 A
LO base load power		280 kW	315 kW	355 kW
LO base load input current at 690 V		306 A	343 A	401 A
LO base load output current at 690 V		294 A	330 A	385 A
HO base load power		250 kW	280 kW	315 kW
HO base load input current at 690 V		251 A	283 A	327 A
HO base load output current at 690 V		240 A	272 A	314 A
Fuse according to IEC		3NE1333-2	3NE1333-2	3NE1334-2
manufacturer:		(450A/690 V) Siemens AG	(450 A/690 V) Siemens AG	(500 A/690 V) Siemens AG
Maximum permissible line short-circuit current I _{kmax}		≤ 100 kA	≤ 100 kA	≤ 100 kA
Minimum line short-circuit current required I _{kmin} ¹⁾		> 3.5 kA	> 3.5 kA	> 4.5 kA
max. power loss, at I _N , 40 °C, 690 V		4.187 kW	5.402 kW	6.191 kW
Required cooling air flow		360 l/s	360 l/s	360 l/s
Maximum connectable cross-section of the power cable		4 x 240 mm ² 4 x 500 kcmil	4 x 240 mm ² 4 x 500 kcmil	4 x 240 mm ² 4 x 500 kcmil
Maximum connectable cross-section of the motor cable		4 x 240 mm ² 4 x 500 kcmil	4 x 240 mm ² 4 x 500 kcmil	4 x 240 mm ² 4 x 500 kcmil
Maximum connectable cross-section of the DC link cable		4 x 240 mm ² 4 x 500 kcmil	4 x 240 mm ² 4 x 500 kcmil	4 x 240 mm ² 4 x 500 kcmil
Recommended cable cross-section for 500 V				
- line cable		2 x 120 mm ²	2 x 120 mm ²	2 x 150 mm ²
- motor cable ³⁾		2 x 120 mm ²	2 x 120 mm ²	2 x 120 mm ²
Recommended cable cross-section for 690 V				
- line cable		2 x 120 mm ²	2 x 120 mm ²	2 x 150 mm ²
- motor cable ³⁾		2 x 95 mm ²	2 x 95 mm ²	2 x 120 mm ²
Recommended cable cross-section for 500 V				
- DC link infeed (2/3 converter power)		2 x 95 mm ²	2 x 95 mm ²	2 x 120 mm ²
Recommended cable cross-section for 690 V				
- DC link infeed (2/3 converter power)		2 x 95 mm ²	2 x 95 mm ²	2 x 120 mm ²
Tightening torque for line, motor, DC link, and ground cable		50 Nm / 443 lbf in	50 Nm / 443 lbf in	50 Nm / 443 lbf in
Dimensions: Width x height x depth [mm]		548 x 1695 x 393	548 x 1695 x 393	548 x 1695 x 393
Weight		157 kg	157 kg	157 kg

Table 6- 5 PM330L, frame size HX, 3 AC 500 V ... 690 V, Part 2

Article No.	6SL3310...	...1CG34-3AA0	...1CG34-8AA0
Rated input current			
- at 500 V, 40 °C		471 A	537 A
- at 600 V, 40 °C		459 A	517 A
- at 690 V, 40 °C		447 A	499 A
- at 500 V, 50 °C		403 A	459 A
- at 600 V, 50 °C		393 A	442 A
- at 690 V, 50 °C		382 A	427 A
Rated output current I_N			
- at 500 V, 40 °C		453 A	516 A
- at 600 V, 40 °C		441 A	497 A
- at 690 V, 40 °C		430 A	480 A
- at 500 V, 50 °C		385 A	438 A
- at 600 V, 50 °C		375 A	422 A
- at 690 V, 50 °C		365 A	408 A
LO base load power		400 kW	450 kW
LO base load input current at 690 V		437 A	489 A
LO base load output current at 690 V		420 A	470 A
HO base load power		355 kW	400 kW
HO base load input current at 690 V		362 A	410 A
HO base load output current at 690 V		348 A	394 A
Fuse according to IEC		3NE1435-2 (560 A/690 V)	3NE1436-2 (630 A/690 V)
manufacturer:		Siemens AG	Siemens AG
Maximum permissible line short-circuit current I_{kmax}		≤ 100 kA	≤ 100 kA
Minimum line short-circuit current required $I_{kmin}^{1)}$		> 7.0 kA	> 8.5 kA
max. power loss, at I_N , 40 °C, 690 V		6.884 kW	7.716 kW
Required cooling air flow		360 l/s	360 l/s
Maximum connectable cross-section of the power cable		4 x 240 mm ² 4 x 500 kcmil	4 x 240 mm ² 4 x 500 kcmil
Maximum connectable cross-section of the motor cable		4 x 240 mm ² 4 x 500 kcmil	4 x 240 mm ² 4 x 500 kcmil
Maximum connectable cross-section of the DC link cable		4 x 240 mm ² 4 x 500 kcmil	4 x 240 mm ² 4 x 500 kcmil
Recommended cable cross-section for 500 V			
- line cable		2 x 185 mm ²	3 x 120 mm ²
- motor cable ³⁾		2 x 150 mm ²	3 x 95 mm ²
Recommended cable cross-section for 690 V			
- line cable		2 x 185 mm ²	3 x 120 mm ²
- motor cable ³⁾		2 x 150 mm ²	3 x 95 mm ²
Recommended cable cross-section for 500 V			
- DC link infeed (2/3 converter power)		2 x 150 mm ²	2 x 150 mm ²
Recommended cable cross-section for 690 V			
- DC link infeed (2/3 converter power)		2 x 150 mm ²	2 x 150 mm ²
Tightening torque for line, motor, DC link, and ground cable		50 Nm / 443 lbf in	50 Nm / 443 lbf in
Dimensions: Width x height x depth [mm]		548 x 1695 x 393	548 x 1695 x 393
Weight		161 kg	161 kg

6.2 Specific technical data

Table 6- 6 PM330L, frame size JX, 3 AC 500 V ... 690 V

Article No.	6SL3310...	...1CG35-3AA0	...1CG36-0AA0	...1CG36-7AA0
Rated input current				
- at 500 V, 40 °C		596 A	679 A	753 A
- at 600 V, 40 °C		578 A	647 A	720 A
- at 690 V, 40 °C		555 A	618 A	690 A
- at 500 V, 50 °C		506 A	577 A	640 A
- at 600 V, 50 °C		492 A	550 A	612 A
- at 690 V, 50 °C		472 A	525 A	587 A
Rated output current I _N				
- at 500 V, 40 °C		581 A	654 A	725 A
- at 600 V, 40 °C		557 A	623 A	693 A
- at 690 V, 40 °C		535 A	595 A	665 A
- at 500 V, 50 °C		494 A	555 A	616 A
- at 600 V, 50 °C		473 A	530 A	589 A
- at 690 V, 50 °C		455 A	506 A	565 A
LO base load power				
LO base load input current at 690 V		500 kW	560 kW	630 kW
LO base load output current at 690 V		540 A	602 A	675 A
		520 A	580 A	650 A
HO base load power				
HO base load input current at 690 V		450 kW	500 kW	560 kW
HO base load output current at 690 V		461 A	494 A	552 A
		444 A	476 A	532 A
Fuse according to IEC				
		3NE1437-2 (710 A/690 V)	3NE1438-2 (800 A/690 V)	3NE1448-2 (850 A/690 V)
manufacturer:				
		Siemens AG	Siemens AG	Siemens AG
Maximum permissible line short-circuit current I _{kmax}				
		≤ 100 kA	≤ 100 kA	≤ 100 kA
Minimum line short-circuit current required I _{kmin} ¹⁾				
		> 10.0 kA	> 11.0 kA	> 13.0 kA
max. power loss, at I _N , 40 °C, 690 V				
		8.134 kW	8.828 kW	9.937 kW
Required cooling air flow				
		450 l/s	450 l/s	450 l/s
Maximum connectable cross-section of the power cable				
		4 x 240 mm ² 4 x 500 kcmil	4 x 240 mm ² 4 x 500 kcmil	4 x 240 mm ² 4 x 500 kcmil
Maximum connectable cross-section of the motor cable				
		4 x 240 mm ² 4 x 500 kcmil	4 x 240 mm ² 4 x 500 kcmil	4 x 240 mm ² 4 x 500 kcmil
Maximum connectable cross-section of the DC link cable				
		4 x 240 mm ² 4 x 500 kcmil	4 x 240 mm ² 4 x 500 kcmil	4 x 240 mm ² 4 x 500 kcmil
Recommended cable cross-section for 500 V				
- line cable		2 x 240 mm ²	3 x 185 mm ²	3 x 185 mm ²
- motor cable ³⁾		2 x 185 mm ²	2 x 240 mm ²	2 x 240 mm ²
Recommended cable cross-section for 690 V				
- line cable		2 x 240 mm ²	3 x 150 mm ²	3 x 185 mm ²
- motor cable ³⁾		2 x 185 mm ²	2 x 240 mm ²	2 x 240 mm ²
Recommended cable cross-section for 500 V				
- DC link infeed (2/3 converter power)		2 x 185 mm ²	2 x 185 mm ²	2 x 240 mm ²
Recommended cable cross-section for 690 V				
- DC link infeed (2/3 converter power)		2 x 150 mm ²	2 x 185 mm ²	2 x 185 mm ²
Tightening torque for line, motor, DC link, and ground cable				
		50 Nm / 443 lbf in	50 Nm / 443 lbf in	50 Nm / 443 lbf in
Dimensions: Width x height x depth [mm]				
		801 x 1621 x 393	801 x 1621 x 393	801 x 1621 x 393
Weight				
		234 kg	234 kg	244 kg

Article No.	6SL3310...	...1CG35-3AA0	...1CG36-0AA0	...1CG36-7AA0
-------------	------------	---------------	---------------	---------------

- 1) The line supply must be capable of supplying the minimum short-circuit current so that the fuses rupture and consequential damage is avoided.
 Note: If the minimum short-circuit current is not reached, the rupture time for the fuses increases, which may result in consequential damage.
- 2) When semiconductor fuses are used, they must be mounted in the same higher construction as the converter.
- 3) The motor cables must be evenly distributed at both connection chambers.

6.3 Derating data.

6.3.1 Derating factor of the output current as a function of the operating temperature

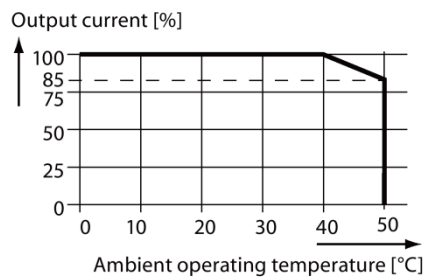

Figure 6-3 Derating factor of the output current as a function of the operating temperature.

6.3.2 Derating as a function of the installation altitude

Voltage

The insulation clearances within the inverter are measured for surge voltages in accordance with overvoltage category III in compliance with IEC 60664-1 for installation altitudes up to 2000 m above sea level.

Use of an isolating transformer to reduce transient overvoltages to IEC 61800-5-1

By using the isolating transformer, overvoltage category III is reduced to overvoltage category II. As a result, the requirements placed on the insulating capability of air are reduced. An additional (input) voltage derating is not necessary if the following basic conditions are met:

- The isolation transformer must be fed from a low-voltage or medium-voltage network; it must not be supplied directly from a high-voltage network.
- The isolating transformer may be connect to one or more converters.

6.3 Derating data.

- The cables between the isolating transformer and the converters must be routed in such a manner as to rule out direct lightning strike, i.e. it is not permissible that overland lines are used.
- The following supply system types are permissible:
 - TN supply systems with grounded star point (no grounded phase conductor)
 - IT supply systems (operation with a ground fault must be limited to the shortest time possible)

Note

The connected motors and power components must be considered separately.

Current

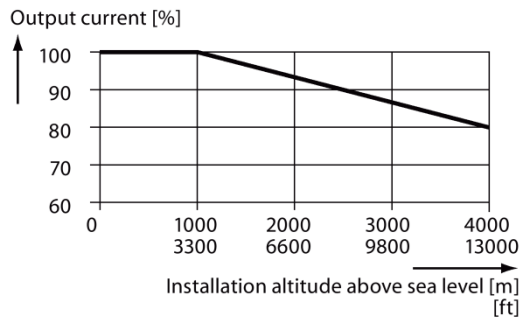

Figure 6-4 Derating of the output current in accordance with the installation altitude with frame sizes HX and JX.

6.3.3 Derating factor of the output current as a function of the line voltage

Table 6- 7 Derating factor of the output current as a function of the line voltage.

Power Module	Rated output current I_N at 380 V	380 V	400 V	415 V	440 V
6SL3310-1CE35-2AA0	535 A	100 %	97.3%	95.2%	91.8%
6SL3310-1CE35-8AA0	605 A	100 %	96.3%	93.5%	88.8%
6SL3310-1CE36-6AA0	670 A	100 %	96.1%	93.2%	88.3%
6SL3310-1CE37-4AA0	750 A	100 %	96.3%	93.6%	89.0%
6SL3310-1CE38-3AA0	840 A	100 %	95.6%	92.3%	86.8%
6SL3310-1CE38-8AA0	925 A	100 %	95.3%	91.7%	85.8%
6SL3310-1CE41-0AA0	1035 A	100 %	95.8%	92.7%	87.5%

Table 6- 8 Derating of the output current as a function of the line voltage, 3 AC 500 V ... 690 V

Power Module	Rated output current I_N at 500 V/690 V	500 V	575 V	600 V	660 V	690 V
6SL3310-1CG33-0AA0	324 A / 300 A	100%	97.9%	96.8%	94.4%	92.6%
6SL3310-1CG33-4AA0	368 A / 340 A	100%	97.0%	95.9%	93.5%	92.4%
6SL3310-1CG33-8AA0	400 A / 393 A	100%	99.3%	99.0%	98.5%	98.3%
6SL3310-1CG34-3AA0	453 A / 430 A	100%	98.0%	97.4%	95.8%	94.9%
6SL3310-1CG34-8AA0	516 A / 480 A	100%	97.3%	96.3%	94.2%	93.0%
6SL3310-1CG35-3AA0	581 A / 535 A	100 %	96.9%	95.4%	93.3 %	92.1 %
6SL3310-1CG36-0AA0	654 A / 595 A	100 %	96.5 %	95.3%	92.4%	91.0%
6SL3310-1CG36-7AA0	725 A / 665 A	100 %	96.7%	95.6%	93.0 %	91.7 %

6.3.4 Derating of the output current as a function of the pulse frequency

In the factory setting, the drive starts with a pulse frequency of 4 kHz and reduces automatically the pulse frequency to the associated required frequencies when loaded. When the load decreases, the pulse frequency is increased automatically up to 4 kHz

The values of the rated current apply to a pulse frequency of 2 kHz at 40° C ambient temperature and are reached at any time by the automatic adaptation of the output pulse frequency.

Appendix

A.1 Further information on your converter

A.1.1 Manuals for your inverter

Table A- 1 Manuals for your converter

Depth of the information	Manual	Contents	Languages	Download or order number
+	Getting Started Control Units CU230P-2; CU240B-2; CU240E-2	Installing the converter and commissioning.	English, German, Italian, French, Spanish and Chinese.	Download manuals (http://support.automation.siemens.com/WWW/view/en/22339653/133300) SINAMICS Manual Collection Documentation on DVD, order number 6SL3097-4CA00-0YG1
+	Getting Started SINAMICS G120 Power Module	Installing the Power Module		
++	Operating Instructions Control Units <ul style="list-style-type: none"> • CU230P-2 	Installing and commissioning the converter, adapting fieldbus interfaces, description of the converter functions, data backup and series commissioning, service and maintenance		
+++	Hardware Installation Manual	This manual		
+++	Operating and installation instructions	For converter accessories, e.g. operator panel, reactors or filter.		
+++	List Manual Control Units <ul style="list-style-type: none"> • CU230P-2 	Graphic function block diagrams. List of all parameters, alarms and faults.	German, English	

A.1.2 Product Support

If you have further questions

You can find additional information on the product and more in the Internet under: Product support (<http://support.automation.siemens.com/WWW/view/en/4000024>).

In addition to our documentation, under this address we offer our complete knowledge base online: You can find the following information:

- Actual product information (Update), FAQ (frequently asked questions), downloads.
- The Newsletter contains the latest information on the products you use.
- The Knowledge Manager (Intelligent Search) helps you find the documents you need.
- Users and specialists from around the world share their experience and knowledge in the Forum.
- You can find your local representative for Automation & Drives via our contact database under "Contact & Partner".
- Information about local service, repair, spare parts and much more can be found under "Services".

A.2 Electromagnetic compatibility

The SINAMICS G120L drives have been tested in accordance with the EMC product standard IEC 61800-3:2004.

For precise data, refer to the declaration conformity

A.2.1 Definition of the EMC Environment and Categories

Classification of EMC behavior

The EMC environment and categories are defined in the EMC Product Standard IEC 61800-3:2004., as follows:

Environments

First Environment

An environment that includes domestic premises and establishments that are connected directly to a public low-voltage line supply without the use of an intermediate transformer.

- Example: houses, apartments, commercial premises or offices in a residential building.

Second environment

An environment that includes all other establishments which are not connected directly to a public low-voltage line supply.

- Example: industrial and technical areas of buildings fed from a dedicated transformer.

Categories

Category C1

Power Drive System (PDS) of rated voltage less than 1000 V intended for use in the First (Domestic) Environment.

Category C2

Power Drive System (PDS) of rated voltage less than 1000 V, which is neither a plug-in device nor a movable device, and when used in the First Environment, is only intended to be installed and commissioned by a professional.

Note

An expert is a person or organization with the necessary experience for installing and/or commissioning drive systems (Power Drive Systems - PDS), including the associated EMC aspects.

Category C3

Power Drive System (PDS) of rated voltage less than 1000 V intended for use in the second (industrial) environment and not intended for use within the first (residential) environment.

A.2.2 Compliance with EMC Environment and Categories

EMC interference emission

Note

To comply with the requirements of IEC 61800-3:2004, all drives must be installed in accordance with the manufacturer's instructions and EMC directives. See also: EMC compliant connection (Page 64).

Cable-conducted (interference voltage) and interference emissions

Category C1 – First environment

- The Power Modules are not intended for use in Category C1, the first environment. In order to be able to use Power Modules in Category C1 – first environment – the following additional measures must be applied (e.g. filter).

Category C2 – First environment - commercial use

Power Modules with additional line filter

- fulfill the requirements relating to cable-conducted noise interference emission (interference), if
 - a shielded cable with low capacitance is used,
 - the current does not exceed the rated input current (see Specific technical data (Page 91)),
 - the pulse frequency does not exceed 4 kHz, and
 - the cable is not longer than 100 m.
- can cause high-frequency disturbances. In this case, damping measures may be required in order that the requirements relating to radiated noise interference can be fulfilled.

Note

Devices for use in Category C2 – first environment, commercial use – must be installed by a specialist with the appropriate experience for installing and/or commissioning power drive systems, including their EMC aspects.

Category C2 – Second environment

Power Modules with additional line filter

- fulfill the requirements relating to cable-conducted noise interference emission (interference), if
 - a shielded cable with low capacitance is used
 - the current does not exceed the rated input current (see Specific technical data (Page 91)),
 - the pulse frequency does not exceed 4 kHz, and
 - the cable is not longer than 100 m.
- can cause high-frequency disturbances. In this case, damping measures may be required in order that the requirements relating to radiated noise interference can be fulfilled.

Category C3 – Second (industrial) environment

- Power Modules can be installed without any restrictions in Category C3 – second environment – and do not require any authorization for connection.

EMC / Immunity

The Power Modules have been tested in accordance with the immunity requirements of category C3 - Second Environment - and fulfill the requirements according to IEC 61800-3.

Note

The immunity requirements apply equally to both filtered and unfiltered Power Modules.

Harmonic currents

Table A- 2 Typical harmonic currents of a 6-pulse rectifier with line reactor $u_k = 2\%$

Typical harmonic current (% of rated input current) with line reactor $u_k = 2\%$										
Line supply with average, relative short-circuit power ($R_{SC} = 50$), $u_k = 2\%$, with line reactor $u_k = 2\%$										
h	1	5	7	11	13	17	19	23	25	THD(I)
I_h	100 %	37.1 %	12.4 %	6.9 %	3.2 %	2.8 %	1.9 %	1.4 %	1.3 %	40.0 %
Line supply with low relative short-circuit power ($R_{SC} < 15$): "Weak line supply", $u_k = 6\%$, with line reactor $u_k = 2\%$										
h	1	5	7	11	13	17	19	23	25	THD(I)
I_h	100 %	22.4 %	7.0 %	3.1 %	2.5 %	1.3 %	1.0 %	0.8 %	0.7 %	23.8 %

h: Harmonic order number

Note

Installation of Power Modules in an environment of category C2

Power Modules which are installed in an environment of category C2 require a connection approval for the low-voltage supply system. Contact your local supply system operator in this case.

A.3 Abbreviations

Abbreviation	State
AC	Alternating Current
CE	European Community
CU	Control Unit
DC	Direct current
DI	Digital input
DIP	DIP switch
DO	Digital output
ECD	Equivalent circuit diagram
ELCB	Earth leakage circuit breaker
EMC	Electromagnetic compatibility
EMI	Electromagnetic interference
HO	High Overload
I/O	In-/output
IGBT	Insulated gate bipolar transistor
LED	Light emitting diode
LO	Light Overload
NC	Normally closed
NEMA	National Electrical Manufacturers Association
NO	Normally open
PELV	Protection by extra low voltage
PM	Power Module
PPE	Personal protective equipment
RCCB	Residual current circuit breaker
RCD	Residual current device
RSC	Relative short-circuit power
RFI	Radio frequency interference
SELV	Safety extra low voltage

Index

C

Category C1, 97
Category C2, 97
Category C3, 97
Classification of EMC behavior, 96

D

Derating, 91; Installation altitude, 91; line voltage, 93;
operating temperature, 91
Disconnect the basic interference suppression module,
56

E

Electrical installation, 41
Electrostatically Sensitive Devices, 10
EMC, 60
EMC interference emission, 97

F

First Environment, 96
Forming the capacitors, 71

G

General rules for protecting against environmental
effects, 19, 21
Getting Started, 95

H

Hardware Installation Manual, 95
Harmonic currents, 99
Hotline, 95

I

Installation altitude, 91
IP20 degree of protection, 19
IT system, 56

L

List Manual, 95

M

Maintenance: Cleaning, 69; Contamination, 69; Dirt,
69; Terminals, 69; Ventilation, 69
Manual Collection, 95
Manuals: Converter accessories, 95; Download, 95;
Overview, 95
Mounting the CU, 39

O

Operating instructions, 95
Operating ranges, 85
Operation on a non-grounded system, 56
Overview: Manuals, 95

P

Partition, 20
Personnel protective equipment, 19
Power Drive System (PDS), 97
Power loss, 21
PPE, 19
Pulse frequency, 93

Q

Questions, 95

R

Removing the CU, 39

Residual risks of drive systems, 12

S

Safety instructions: Electromagnetic fields, 10;

Electrostatically Sensitive Devices, 10; General
safety instructions, 7

Safety notes: Electrical installation, 41

Second environment, 96

Service life of the fan, 73

Standards: IEC 61800-3, 96; IEC 61800-3:2004, 96

Star/delta connection, 53

Support, 95

T

Technical data: General, 83

U

Ungrounded system, 56

Get more information

SINAMICS G120L
General Purpose Single Drive Converter
www.ad.siemens.com.cn/download/

SINAMICS drive family:
www.siemens.com/sinamics

Integrated Drive Systems:
www.siemens.com/ids

Partners worldwide:
www.siemens.com/automation/partner

Security information

Siemens provides products and solutions with industrial security functions that support the secure operation of plants, solutions, machines, equipment and/or networks. They are important components in a holistic industrial security concept. With this in mind, Siemens' products and solutions undergo continuous development. Siemens recommends strongly that you regularly check for product updates.

For the secure operation of Siemens products and solutions, it is necessary to take suitable preventive action (e.g. cell protection concept) and integrate each component into a holistic, state-of-the-art industrial security concept. Third-party products that may be in use should also be considered. For more information about industrial security, visit

www.siemens.com/industrialsecurity

To stay informed about product updates as they occur, sign up for a product-specific newsletter. For more information, visit

<http://support.automation.siemens.com>

Please scan the QR code for more information on SINAMICS G120L



Siemens Ltd., China
Process Industries and Drives Division
Large Drives Business Unit

Subject to change without prior notice

Printed in China
© Siemens China 2016

The order no. PDL-D-C80005-00-76CN
746-S902812-11150

The information provided in this catalog contains merely general descriptions or characteristics of performance which in case of actual use do not always apply as described or which may change as a result of further development of the products. An obligation to provide the respective characteristics shall only exist if expressly agreed in the terms of contract. Availability and technical specifications are subject to change without notice.

All product designations may be trademarks or product names of Siemens AG or supplier companies whose use by third parties for their own purposes could violate the rights of the owners.