

SIEMENS

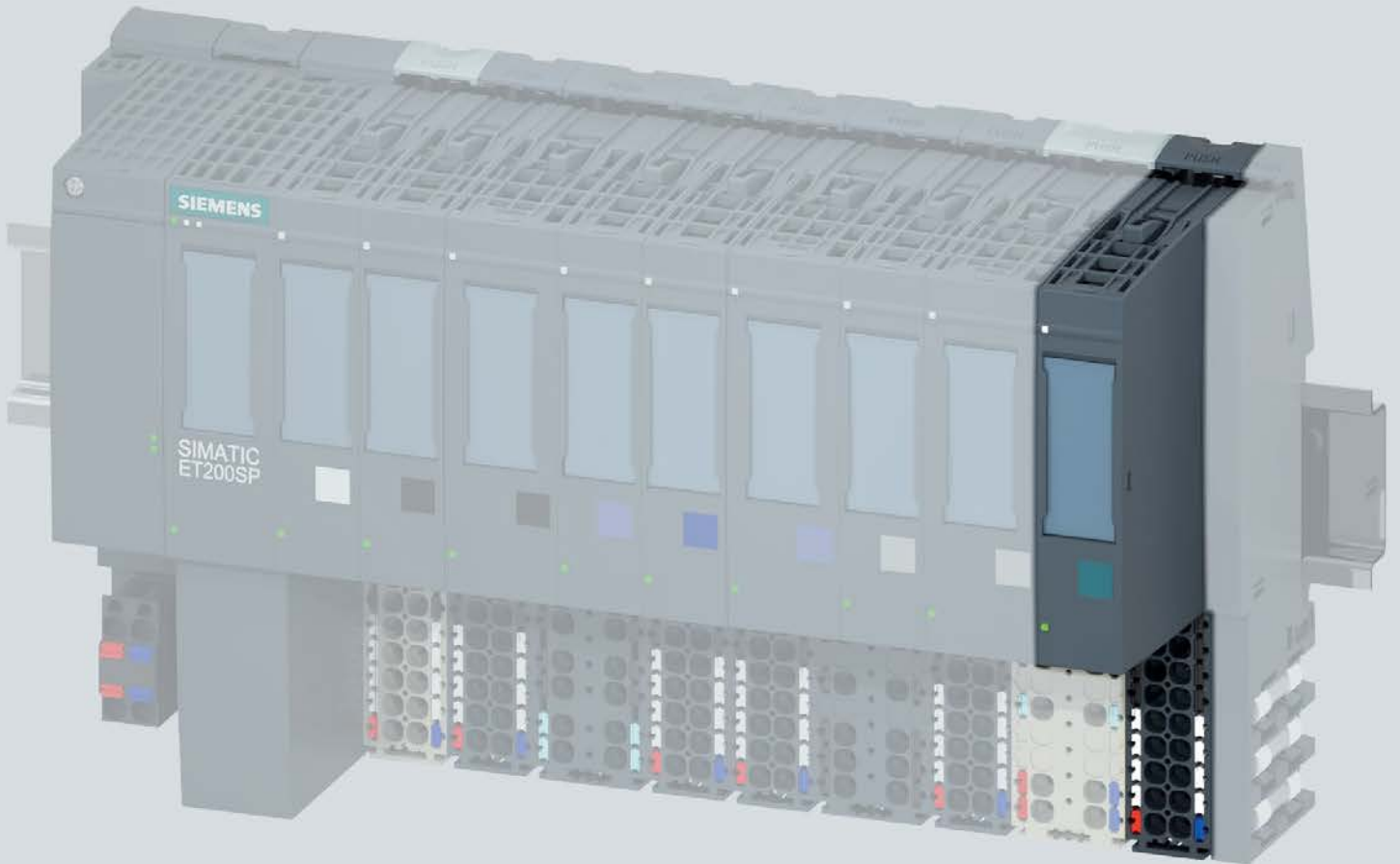

Manual

SIMATIC

ET 200SP

Technology module
TM Count 1x24V (6ES7138-6AA00-0BA0)

Edition

06/2018

SIEMENS

SIMATIC

ET 200SP Technology Module TM Count 1x24V (6ES7138-6AA00-0BA0)

Manual

Preface

Documentation guide

1

Product overview

2

Wiring

3

Configuring/address space

4

Interrupts/diagnostic
messages

5

Technical specifications

6

Parameter data record

A

Legal information

Warning notice system

This manual contains notices you have to observe in order to ensure your personal safety, as well as to prevent damage to property. The notices referring to your personal safety are highlighted in the manual by a safety alert symbol, notices referring only to property damage have no safety alert symbol. These notices shown below are graded according to the degree of danger.

⚠ DANGER
indicates that death or severe personal injury will result if proper precautions are not taken.
⚠ WARNING
indicates that death or severe personal injury may result if proper precautions are not taken.
⚠ CAUTION
indicates that minor personal injury can result if proper precautions are not taken.
NOTICE
indicates that property damage can result if proper precautions are not taken.

If more than one degree of danger is present, the warning notice representing the highest degree of danger will be used. A notice warning of injury to persons with a safety alert symbol may also include a warning relating to property damage.

Qualified Personnel

The product/system described in this documentation may be operated only by **personnel qualified** for the specific task in accordance with the relevant documentation, in particular its warning notices and safety instructions. Qualified personnel are those who, based on their training and experience, are capable of identifying risks and avoiding potential hazards when working with these products/systems.

Proper use of Siemens products

Note the following:

⚠ WARNING
Siemens products may only be used for the applications described in the catalog and in the relevant technical documentation. If products and components from other manufacturers are used, these must be recommended or approved by Siemens. Proper transport, storage, installation, assembly, commissioning, operation and maintenance are required to ensure that the products operate safely and without any problems. The permissible ambient conditions must be complied with. The information in the relevant documentation must be observed.

Trademarks

All names identified by ® are registered trademarks of Siemens AG. The remaining trademarks in this publication may be trademarks whose use by third parties for their own purposes could violate the rights of the owner.

Disclaimer of Liability

We have reviewed the contents of this publication to ensure consistency with the hardware and software described. Since variance cannot be precluded entirely, we cannot guarantee full consistency. However, the information in this publication is reviewed regularly and any necessary corrections are included in subsequent editions.

Preface

Purpose of the documentation

This manual includes module-specific information on wiring, diagnostics and the technical specifications of the technology module.

General information regarding design and commissioning of the ET 200SP is available in the ET 200SP system manual.

The counting and measuring functions of the TM Count 1x24V technology module are described in more detail in the Counting, Measurement and Position Detection (<http://support.automation.siemens.com/WW/view/en/59709820>) function manual.

Conventions

Please observe notes marked as follows:

Note

A note contains important information on the product described in the documentation, on the handling of the product and on the section of the documentation to which particular attention should be paid.

Security information

Siemens provides products and solutions with industrial security functions that support the secure operation of plants, systems, machines and networks.

In order to protect plants, systems, machines and networks against cyber threats, it is necessary to implement – and continuously maintain – a holistic, state-of-the-art industrial security concept. Siemens' products and solutions only form one element of such a concept.

Customer is responsible to prevent unauthorized access to its plants, systems, machines and networks. Systems, machines and components should only be connected to the enterprise network or the internet if and to the extent necessary and with appropriate security measures (e.g. use of firewalls and network segmentation) in place.

Additionally, Siemens' guidance on appropriate security measures should be taken into account. For more information about industrial security, please visit (<http://www.siemens.com/industrialsecurity>).

Siemens' products and solutions undergo continuous development to make them more secure. Siemens strongly recommends to apply product updates as soon as available and to always use the latest product versions. Use of product versions that are no longer supported, and failure to apply latest updates may increase customer's exposure to cyber threats.

To stay informed about product updates, subscribe to the Siemens Industrial Security RSS Feed under (<http://www.siemens.com/industrialsecurity>).

Open Source Software

Open-source software is used in the firmware of the product described. Open Source Software is provided free of charge. We are liable for the product described, including the open-source software contained in it, pursuant to the conditions applicable to the product. Siemens accepts no liability for the use of the open source software over and above the intended program sequence, or for any faults caused by modifications to the software.

For legal reasons, we are obliged to publish the original text of the license conditions and copyright notices. Please read the information on this on the Internet (<https://support.industry.siemens.com/cs/ww/en/view/109740777>).

Table of contents

	Preface	3
1	Documentation guide	7
2	Product overview	11
2.1	Properties.....	11
2.2	Functions	15
2.2.1	Detection of counting signals.....	15
2.2.2	Measured value determination	16
2.2.3	Switching the outputs at comparison values	16
2.2.4	Position input for Motion Control.....	17
2.2.5	Fast Mode.....	17
2.2.6	Additional functions.....	18
3	Wiring	19
3.1	Pin assignment and block diagram.....	19
4	Configuring/address space.....	23
4.1	Operating with "Counting and measurement" technology object	23
4.1.1	Configuring.....	23
4.1.2	Reaction to CPU STOP	24
4.1.3	Parameter setting.....	24
4.1.4	Address space	30
4.1.5	Isochronous mode	31
4.2	Position input for ""Motion Control"" technology object	32
4.2.1	Configuring.....	32
4.2.2	Parameter setting.....	34
4.2.3	Address space	36
4.2.4	Isochronous mode	36
4.3	Manual operation (without technology object)	38
4.3.1	Configuring.....	38
4.3.2	Reaction to CPU STOP	40
4.3.3	Parameter setting.....	41
4.3.4	Address space	47
4.3.5	Control and feedback interface.....	47
4.3.5.1	Assignment of the control interface	47
4.3.5.2	Assignment of the feedback interface.....	50
4.3.6	Isochronous mode	53

4.4	Fast Mode	54
4.4.1	Configuring	55
4.4.2	Reaction to CPU STOP	57
4.4.3	Parameter setting	57
4.4.4	Explanation of parameters	62
4.4.5	Address space	71
4.4.6	Assignment of the feedback interface	71
4.4.7	Isochronous mode	73
5	Interrupts/diagnostic messages	74
5.1	Status and error display	74
5.2	Diagnostic messages	77
5.3	Hardware interrupts	81
6	Technical specifications	83
A	Parameter data record	91
A.1	Parameter assignment and structure of parameter data record	91
A.2	Parameter validation error	101

Documentation guide

The documentation for the SIMATIC ET 200SP distributed I/O system is arranged into three areas.

This arrangement enables you to access the specific content you require.

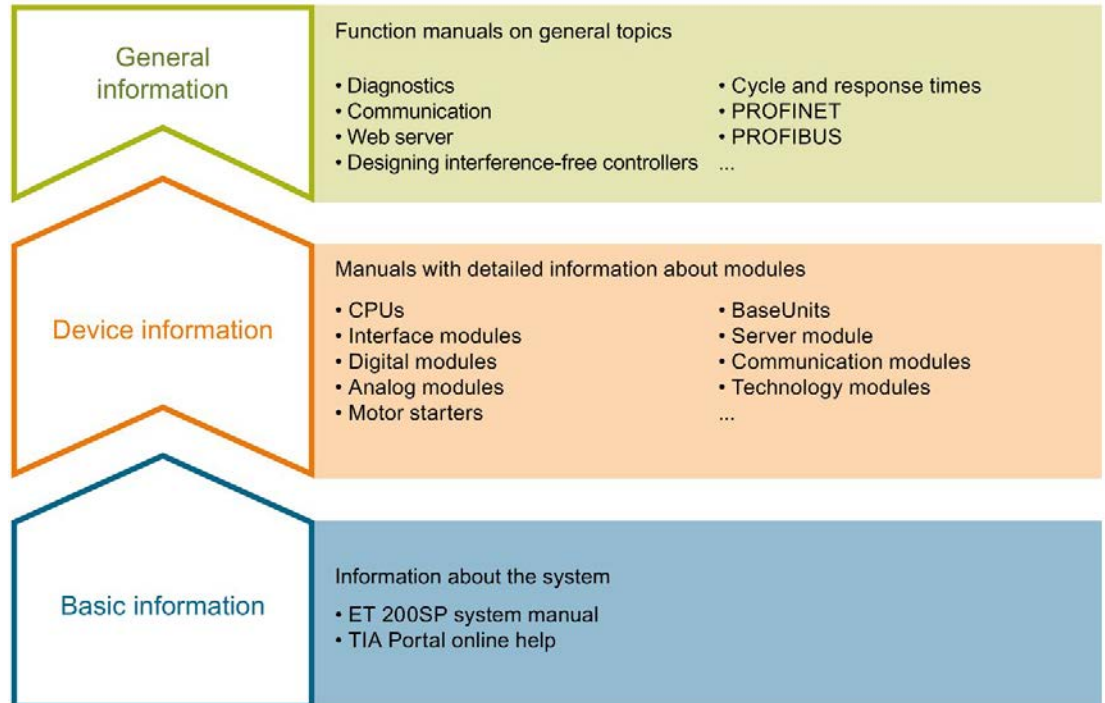

Basic information

The system manual describes in detail the configuration, installation, wiring and commissioning of the SIMATIC ET 200SP. distributed I/O system. The STEP 7 online help supports you in the configuration and programming.

Device information

Product manuals contain a compact description of the module-specific information, such as properties, wiring diagrams, characteristics and technical specifications.

General information

The function manuals contain detailed descriptions on general topics regarding the SIMATIC ET 200SP distributed I/O system, e.g. diagnostics, communication, Web server, motion control and OPC UA.

You can download the documentation free of charge from the Internet (<https://support.industry.siemens.com/cs/ww/en/view/109742709>).

Changes and supplements to the manuals are documented in a Product Information.

You can download the product information free of charge from the Internet (<https://support.industry.siemens.com/cs/us/en/view/73021864>).

Manual Collection ET 200SP

The Manual Collection contains the complete documentation on the SIMATIC ET 200SP distributed I/O system gathered together in one file.

You can find the Manual Collection on the Internet (<https://support.industry.siemens.com/cs/ww/en/view/84133942>).

"mySupport"

With "mySupport", your personal workspace, you make the most of your Industry Online Support.

In "mySupport" you can store filters, favorites and tags, request CAx data and put together your personal library in the Documentation area. Furthermore, your data is automatically filled into support requests and you always have an overview of your current requests.

You need to register once to use the full functionality of "mySupport".

You can find "mySupport" in the Internet (<https://support.industry.siemens.com/My/ww/en>).

"mySupport" - Documentation

In the Documentation area of "mySupport", you have the possibility to combine complete manuals or parts of them to make your own manual.

You can export the manual in PDF format or in an editable format.

You can find "mySupport" - Documentation in the Internet (<http://support.industry.siemens.com/My/ww/en/documentation>).

"mySupport" - CAx Data

In the CAx Data area of "mySupport", you can have access the latest product data for your CAx or CAe system.

You configure your own download package with a few clicks.

In doing so you can select:

- Product images, 2D dimension drawings, 3D models, internal circuit diagrams, EPLAN macro files
- Manuals, characteristics, operating manuals, certificates
- Product master data

You can find "mySupport" - CAx Data in the Internet (<http://support.industry.siemens.com/my/ww/en/CAxOnline>).

Application examples

The application examples support you with various tools and examples for solving your automation tasks. Solutions are shown in interplay with multiple components in the system - separated from the focus in individual products.

You can find the application examples on the Internet (<https://support.industry.siemens.com/sc/ww/en/sc/2054>).

TIA Selection Tool

With the TIA Selection Tool, you can select, configure and order devices for Totally Integrated Automation (TIA).

This tool is the successor of the SIMATIC Selection Tool and combines the known configurators for automation technology into one tool.

With the TIA Selection Tool, you can generate a complete order list from your product selection or product configuration.

You can find the TIA Selection Tool on the Internet

(<http://w3.siemens.com/mcms/topics/en/simatic/tia-selection-tool>).

SIMATIC Automation Tool

You can use the SIMATIC Automation Tool to run commissioning and maintenance activities simultaneously on various SIMATIC S7 stations as a bulk operation independently of the TIA Portal.

The SIMATIC Automation Tool provides a multitude of functions:

- Scanning of a PROFINET/Ethernet network and identification of all connected CPUs
- Address assignment (IP, subnet, gateway) and station name (PROFINET device) to a CPU
- Transfer of the data and the programming device/PC time converted to UTC time to the module
- Program download to CPU
- Operating mode switchover RUN/STOP
- Localization of the CPU by means of LED flashing
- Reading out CPU error information
- Reading the CPU diagnostic buffer
- Reset to factory settings
- Updating the firmware of the CPU and connected modules

You can find the SIMATIC Automation Tool on the Internet

(<https://support.industry.siemens.com/cs/ww/en/view/98161300>).

PRONETA

With SIEMENS PRONETA (PROFINET network analysis), you analyze the plant network during commissioning. PRONETA features two core functions:

- The topology overview independently scans PROFINET and all connected components.
- The IO check is a fast test of the wiring and the module configuration of a system.

You can find SIEMENS PRONETA on the Internet

(<https://support.industry.siemens.com/cs/ww/en/view/67460624>).

SINETPLAN

SINETPLAN, the Siemens Network Planner, supports you in planning automation systems and networks based on PROFINET. The tool facilitates professional and predictive dimensioning of your PROFINET installation as early as in the planning stage. In addition, SINETPLAN supports you during network optimization and helps you to exploit network resources optimally and to plan reserves. This helps to prevent problems in commissioning or failures during productive operation even in advance of a planned operation. This increases the availability of the production plant and helps improve operational safety.

The advantages at a glance

- Network optimization thanks to port-specific calculation of the network load
- Increased production availability thanks to online scan and verification of existing systems
- Transparency before commissioning through importing and simulation of existing STEP 7 projects
- Efficiency through securing existing investments in the long term and optimal exploitation of resources

You can find SINETPLAN on the Internet (<https://www.siemens.com/sinetplan>).

Product overview

2.1 Properties

Article number

6ES7138-6AA00-0BA0

Firmware version

This manual describes the properties of the module with firmware version V1.3.

View of the module

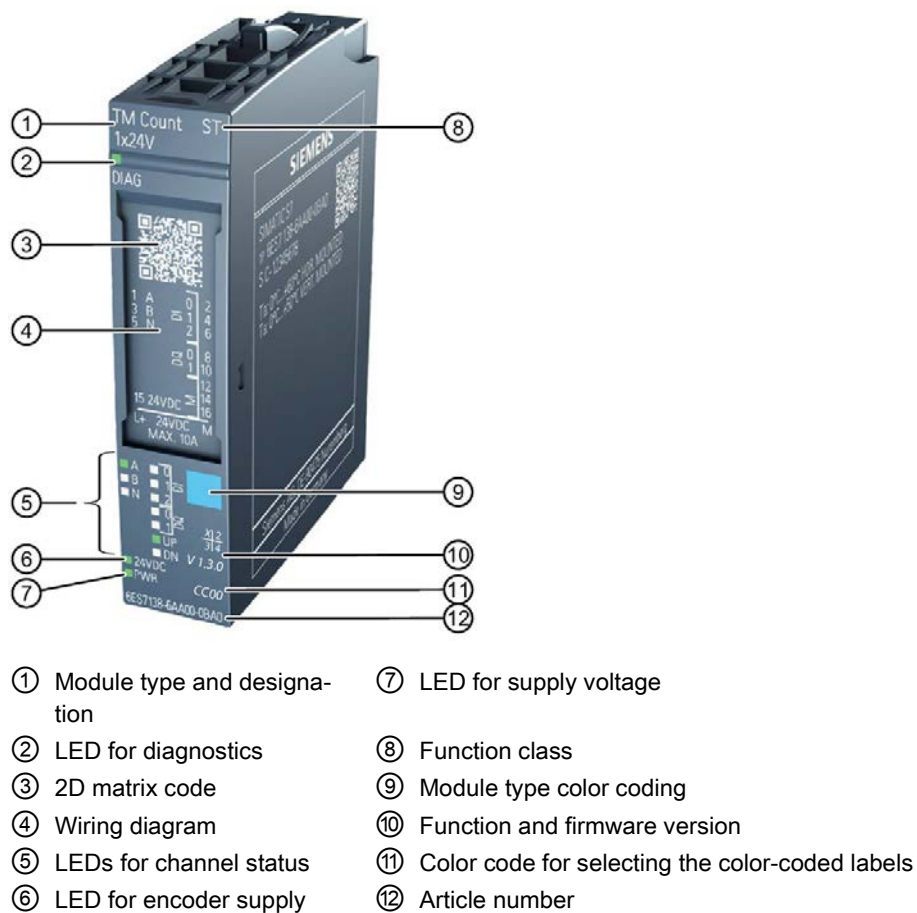

- ① Module type and designation
- ② LED for diagnostics
- ③ 2D matrix code
- ④ Wiring diagram
- ⑤ LEDs for channel status
- ⑥ LED for encoder supply
- ⑦ LED for supply voltage
- ⑧ Function class
- ⑨ Module type color coding
- ⑩ Function and firmware version
- ⑪ Color code for selecting the color-coded labels
- ⑫ Article number

Figure 2-1 View of the TM Count 1x24V module

Properties

The TM Count 1x24V technology module has the following properties:

- Technical properties
 - One channel
 - Interfaces:
 - 24 V encoder signals A, B and N from sourcing, sinking or push-pull encoders and sensors
 - 24 V encoder supply, short-circuit-proof
 - DI0, DI1 and DI2 digital input signals
 - DQ0 and DQ1 digital output signals
 - Supply voltage L+
 - Count range: 32 bits
 - Monitoring of encoder signals for wire break
 - Hardware interrupts configurable
 - Input filters for suppression of interferences at encoder inputs and digital inputs can be configured
- Supported encoder/signal types
 - 24 V incremental encoder with N signal
 - 24 V incremental encoder without N signal
 - 24 V pulse encoder with direction signal
 - 24 V pulse encoder without direction signal
 - 24 V pulse encoder with up/down counting signal
- Supported system functions
 - Isochronous mode
 - Firmware update
 - Identification data I&M

The module supports the following functions:

Table 2- 1 Version dependencies of the functions

Function	Firmware version of module	Configurable as of			
		STEP 7 (TIA Portal)	STEP 7	GSD	
				PROFINET IO	PROFIBUS DP
Firmware update	V1.0 or higher	V13	V5.5 SP4	X	—
I&M identification data	V1.0 or higher	V13	V5.5 SP4	X	X
Parameter reassignment in RUN	V1.0 or higher	V13	V5.5 SP4	X	X
Isochronous mode	V1.0 or higher	V13	V5.5 SP4	—	—
Counting/measuring	V1.0 or higher	V13	V5.5 SP4 or V5.5 SP3 with HSP0240 V1.0	X	X
Operating with "Counting and measurement" technology object	V1.0 or higher	V13	—	—	—
Position input for "Motion Control" technology object	V1.0 or higher	V13	—	—	—
Central operation on CPU 151xSP	V1.1 or higher	V13 SP1	—	—	—
Fast Mode	V1.2 or higher	V14 SP1 or V14 with HSP0199	V5.6 or V5.5 SP4 with HSP0240 V5.0	X	X
Operating with "Measuring input" technology object	V1.3 or higher	V15 with HSP0256	—	—	—
Position value range of 32 bits	V1.3 or higher	V15 with HSP0256	—	X	X

Accessories

The following accessories can be used with the module and are not included in the scope of delivery:

- Labeling strip
- Color identification labels
- Reference identification labels
- Shield connector

A BaseUnit of the A0 type is required to operate the technology module. You can find an overview of the BaseUnits that you can use with the technology module in the product information for the documentation of the ET 200SP distributed I/O system (<http://support.automation.siemens.com/WW/view/en/73021864>).

For detailed information on the installation procedure, refer to the ET 200SP Distributed I/O System (<http://support.automation.siemens.com/WW/view/en/58649293>) system manual.

2.2 Functions

2.2.1 Detection of counting signals

Counting is the detecting and adding up of events. The counters of the technology module detect encoder signals and pulses and evaluate them accordingly. The count direction can be specified using encoder or pulse signals or through the user program.

You can control the counting processes with the digital inputs. In addition, you can read the signal state of the respective digital input via the feedback interface.

You can specify the counter characteristics using the functions described below.

Counting limits

The counting limits define the counter value range used. The counting limits are configurable and can be modified during runtime with the user program.

You can configure the behavior of the counter at the counting limits.

Start value

You can configure a start value within the counting limits. The start value can be modified during runtime with the user program.

Gate control

You can define the time window in which the count signals are acquired with the hardware gate (HW gate) and software gate (SW gate).

Capture (Latch)

You can configure an external reference signal edge that triggers the saving of the current counter value as Capture value. The following external signals can trigger the Capture function:

- Rising or falling edge of a digital input
- Both edges of a digital input
- Rising edge of the N signal at the encoder input

The "Frequency of Capture function" parameter specifies whether the function is executed at each configured edge or only once after each enable.

Measuring input

If you use Position input for Motion Control (Page 17), you can use the "Measuring input" technology object to execute a measuring input function with a hardware digital input.

Hardware interrupts

The technology module can trigger a hardware interrupt in the CPU, for example, if a comparison event occurs, in the event of overflow or underflow, in the event of a zero crossing of the counter and/or of a change of count direction (direction reversal). You can specify which events during operation are to trigger a hardware interrupt.

2.2.2 Measured value determination

The following high-accuracy measurement functions are available (accuracy up to 100 ppm):

- Frequency measurement with the unit of hertz
- Period measurement with the unit of seconds
- Velocity measurement with a flexibly adaptable unit

Update time

You can configure the interval at which the technology module updates the measured values cyclically as the update time.

Gate control

You can define the time window in which the count signals are acquired with the hardware gate (HW gate) and software gate (SW gate).

2.2.3 Switching the outputs at comparison values

The available digital outputs DQ0 and DQ1 can be directly activated/switched by the specified comparison values or via the user program. The comparison values are configurable and can be modified during runtime with the user program. This enables very fast reaction times to be achieved.

Comparison values in the Counting mode

You define two comparison values in the Counting mode. If the current counter value meets the configured comparison condition, the corresponding digital output can be set to directly initiate control processes in the process.

Comparison values in the Measuring mode

You define two comparison values in the Measuring mode. If the current measured value meets the configured comparison condition, the corresponding digital output can be set to directly initiate control processes in the process.

2.2.4 Position input for Motion Control

You can use the technology module for position detection for the following axis technology objects of S7-1500 Motion Control :

- TO_PositioningAxis
- TO_SynchronousAxis
- TO_ExternalEncoder

In this operating mode, you can use the measuring input technology object (TO_MeasuringInput) to execute a measuring input function with hardware digital input DI1.

Additional information

You can find a detailed description of the use of Motion Control and its configuration in the following:

- Function manual S7-1500 Motion Control available for download on the Internet (<http://support.automation.siemens.com/WW/view/en/59381279>)
- Function manual S7-1500T Motion Control available for download on the Internet (<https://support.industry.siemens.com/cs/ww/en/view/109481326>)

2.2.5 Fast Mode

You can use the technology module in Fast Mode for very fast acquisition of counter or position value with compressed functionality. A reduced feedback interface but no control interface is available in Fast Mode. This allows you to use a shorter send clock for the CPU.

2.2.6 Additional functions

Synchronization

You can configure the edge of an external reference signal that loads the counter with the specified start value. The following external signals can trigger a synchronization:

- Rising or falling edge of a digital input
- Rising edge of signal N at the encoder input
- Rising edge of signal N at the encoder input depending on the level of the assigned digital input

The "Frequency of synchronization" parameter specifies whether the function is executed at each configured edge or only once after each enable.

Hysteresis

You can specify a hysteresis for the comparison values within which a digital output will be prevented from switching again.

Diagnostic interrupt

The technology module can trigger diagnostic interrupts. You enable the diagnostic interrupts in the device configuration.

Input filter

To suppress interference, you can configure an input filter for the 24 V encoder inputs and for the digital inputs.

Isochronous mode

The technology module supports the "Isochronous mode" system function. This system function enables counter values and measured values to be acquired in a defined system cycle.

Wiring

3.1 Pin assignment and block diagram

Das TM Count 1x24V is used with a BaseUnit of type A0 (article number 6ES7193-6BPx0-0xA0).

You connect the encoder signals, the digital input and output signals and the encoder supplies to the BaseUnit of the technology module. The supply voltage feed on the light BaseUnit BU...D of the associated potential group supplies the module and the digital outputs, and generates the encoder supply voltage.

BaseUnit

The BaseUnit is not included in the scope of delivery of the module and must be ordered separately.

You can find an overview of the BaseUnits that you can use with the technology module in the product information for the documentation of the ET 200SP distributed I/O system (<http://support.automation.siemens.com/WW/view/en/73021864>).

You can find information about selecting a suitable BaseUnit in the ET 200SP Distributed I/O System (<http://support.automation.siemens.com/WW/view/en/58649293>) system manual and ET 200SP BaseUnits (<http://support.automation.siemens.com/WW/view/en/58532597/133300>) device manual.

You can find information on wiring the BaseUnit, connecting cable shields, etc. in the Connecting section of the ET 200SP Distributed I/O System (<http://support.automation.siemens.com/WW/view/en/58649293>) system manual.

Supply voltage L+/M

You connect the supply voltage to terminals L+ and M on a light BaseUnit. For a dark BaseUnit, the supply voltage of the module to the left is used. An internal protection circuit protects the technology module from reverse polarity of the supply voltage. The technology module monitors whether the supply voltage is connected.

Encoder supply

For supplying the encoders and sensors connected to the digital inputs, the technology module provides a 24 V DC supply voltage at output 24VDC (terminal 15) with reference to M (terminals 12, 14 and 16). The voltage is monitored for short-circuit and overload.

Digital inputs DI0, DI1 and DI2

The digital inputs are used for gate control, synchronization and the Capture function.

The digital inputs are not isolated from each other.

Input delay for digital inputs

In order to suppress noise you can configure an input delay for the digital inputs.

Note

If you select the "None" or "0.05 ms" option, you must use shielded cables for connection of the digital inputs.

Digital outputs DQ0 and DQ1

The digital outputs are not isolated from each other.

The digital outputs are 24 V sourcing outputs in reference to M and can carry a rated load current of 0.5 A. They are protected against overload and short-circuit.

Relays and contactors can be directly connected without an external protective circuit. You can find information on the maximum possible operating frequencies and the inductive loads connected to the digital outputs in section Technical specifications (Page 83).

24 V encoder signals/count signals

The 24 V encoder signals are designated with the letters A, B and N. You can connect the following encoder types:

- Incremental encoder with N signal:
The A, B and N signals are connected using the correspondingly marked terminals. The A and B signals are the two 90° phase-shifted incremental signals. N is the zero mark signal that supplies one pulse per revolution.
- Incremental encoder without N signal:
The A and B signals are connected using the correspondingly marked terminals. The A and B signals are the two 90° phase-shifted incremental signals. The N terminal remains unconnected.
- Pulse encoder without direction signal:
The counting signal is connected to the A terminal. The count direction can be specified via the control interface. The B and N terminals remain unconnected.
- Pulse encoder with direction signal:
The counting signal is connected to the A terminal. The direction signal is connected to the B terminal. Counting down takes place at a high level of the direction signal. The N terminal remains unconnected.
- Pulse encoder with up/down counting signal:
The up counting signal is connected to the A terminal. The down counting signal is connected to the B terminal. The N terminal remains unconnected.

The inputs are not isolated from each other. The inputs are isolated from the backplane bus.

You can connect the following encoders or sensors to the A, B and N inputs:

- Sourcing output:
The A, B and N inputs are switched by the encoder or sensor to 24VDC .
- Sinking output:
The A, B and N inputs are switched by the encoder or sensor to ground M .
- Push-pull:
The A, B and N inputs are switched by the encoder or sensor alternately to 24VDC and ground M . Monitoring for wire break is possible with this type of encoder/sensor. The procedure of the wire break detection (alternate switching) requires that, in the event of a fault (wire break), the count can also change without a counting pulse until the wire break is detected.

Pin assignment of the BaseUnit

The table below shows the pin assignment, using the BaseUnit BU15-P16+A0+2B as an example.

Table 3- 1 Pin assignment of the BaseUnit BU15-P16+A0+2B

Designation					Signal name		View	Signal name		Designation	
24 V incremental encoder		24 V pulse encoder			A	1		2	DI0		Digital input DI0
with signal N	without signal N	with direction signal	without direction signal	up/down							
Encoder signal A	Counting signal A		Up counting signal A		B	3	4	DI1	Digital input DI1		
Encoder signal B	Direction signal B	—		Down counting signal B	N	5	6	DI2	Digital input DI2		
Encoder signal N	—				—	7	8	DQ0	Digital output DQ0		
—					—	9	10	DQ1	Digital output DQ1		
—					—	11	12	M	Ground for encoder supply, digital inputs and digital outputs		
—					—	13	14	M			
Encoder supply 24 V DC					24VDC	15	16	M	Ground for supply voltage		
Supply voltage DC 24 V					L+		M				

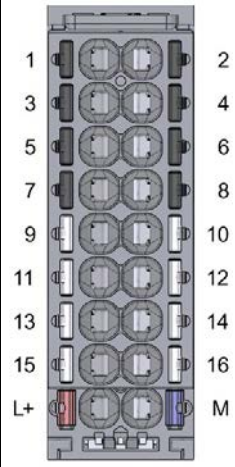

Block diagram

The figure below shows the block diagram of the technology module.

You must ground the shields of the cables between encoder and technology module both through the shield terminal on the BaseUnit (shield bracket and terminal) and also on the encoder.

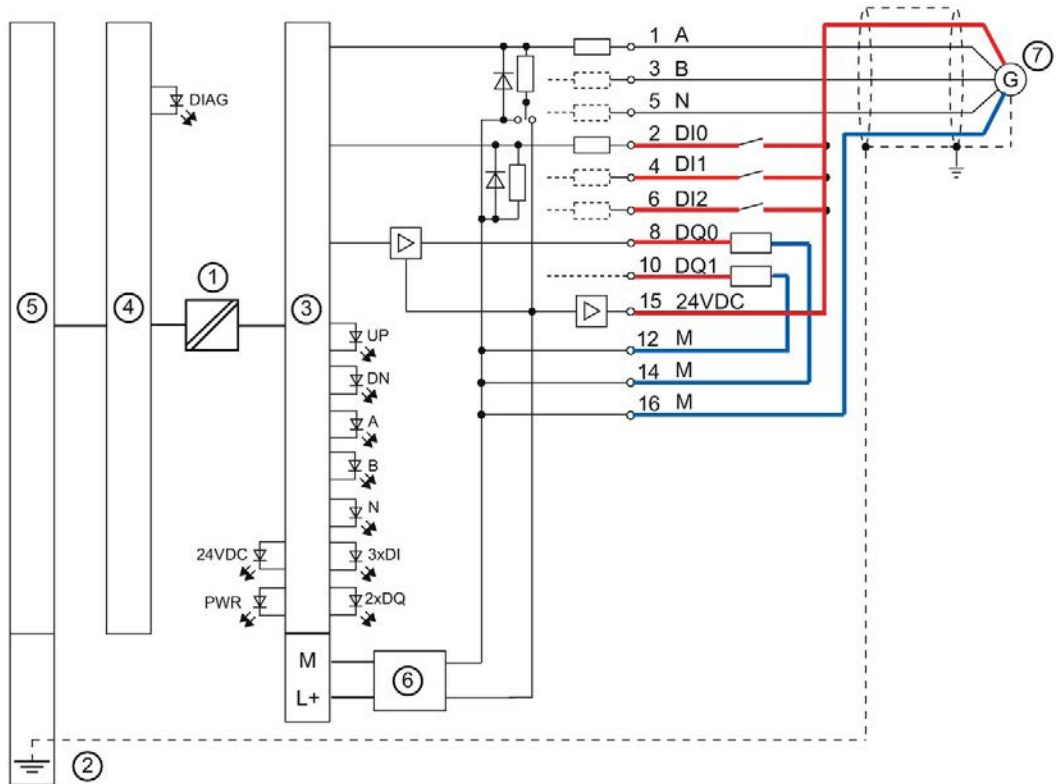

- ① Electrical isolation
- ② Shield terminal on the BaseUnit
- ③ Technology
- ④ Backplane bus interface module of the technology module
- ⑤ Backplane bus
- ⑥ Input filter
- ⑦ Incremental encoder with signal N

Figure 3-1 Block diagram with incremental encoder

Configuring/address space

4.1 Operating with "Counting and measurement" technology object

4.1.1 Configuring

Introduction

You configure the technology module and assign its parameters with STEP 7 (TIA Portal).
The technology object is used to control and monitor the functions of the technology module.

System environment

The technology module can be used in the following system environments:

Applications	Components required	Configuration software	In the user program
Central operation with a CPU 151xSP	<ul style="list-style-type: none"> S7-1500 automation system TM Count 1x24V 	STEP 7 (TIA Portal): <ul style="list-style-type: none"> Device configuration with hardware configuration Parameter setting with High_Speed_Counter technology object 	High_Speed_Counter instruction
Distributed operation with an S7-1500 CPU	<ul style="list-style-type: none"> S7-1500 automation system ET 200SP distributed I/O system TM Count 1x24V 		

Additional information

You can find a detailed description of the counting and measurement functions and their configuration in the following:

- Function manual Counting, Measurement and Position Detection available for download on the Internet (<http://support.automation.siemens.com/WW/view/en/59709820>)
- Information system of STEP 7 (TIA Portal) under "Using technology functions > Counting, measurement and position input > Counting, measurement and position input (S7-1500)"

Hardware Support Packages (HSP)

If firmware version V1.3 of the module is not yet integrated in your TIA Portal Version V15, you can integrate a corresponding module using HSP0256.

You can find the Hardware Support Packages (HSP) for download on the Internet (<https://support.industry.siemens.com/cs/ww/en/view/72341852>).

You can also access this download from the menu bar of STEP 7 (TIA Portal): "Options > Support packages > Download from the Internet".

4.1.2 Reaction to CPU STOP

You set the response of the technology module to CPU STOP for each channel in the basic parameters of the device configuration.

Table 4- 1 Response of technology module to CPU STOP

Option	Meaning
Continue operation	The technology module remains fully functional. Incoming count pulses are processed. The digital outputs continue to switch according to the parameter assignment.
Output substitute value	The technology module outputs the configured substitute values at the digital outputs until the next CPU STOP-RUN transition. The technology module is returned to its startup state after a STOP-RUN transition: The counter value is set to the start value and the digital outputs switch according to the parameter assignment.
Keep last value	The technology module outputs the values at the digital outputs that were valid when the transition to STOP took place until the next CPU STOP-RUN transition. If a digital output with the function "At comparison value for a pulse duration" is set at CPU stop, the digital output is reset after the pulse duration elapses. The technology module is returned to its startup state after a STOP-RUN transition: The counter value is set to the start value and the digital outputs switch according to the parameter assignment.

4.1.3 Parameter setting

You specify the properties of the technology module using various parameters. Depending on the settings, not all parameters are available. When parameters are assigned in the user program, the parameters are transferred to the module with the "WRREC" instruction and data record 128 (Page 91).

You set the parameters of the module as follows in this operating mode:

1. Insert the module from the hardware catalog under "Technology modules".
2. Set the device configuration in the hardware configuration.
"Operating with "Counting and measurement" technology object" must be set as the operating mode.
3. Insert the High_Speed_Counter technology object from the project tree in folder "Technology objects > Add new object > Counting and measurement".
You can find information on configuring with a technology object in function manual Counting, measurement and position detection (<http://support.automation.siemens.com/WW/view/en/59709820>).
4. Open the configuration of the High_Speed_Counter technology object, e.g. using the Configuration button  in the instruction for the technology object.
5. Set the parameters of the technology object.
6. Download the project to the CPU.

Parameters of the TM Count 1x24V

The following parameter settings are possible in the hardware configuration:

Table 4- 2 Settable parameters and their default setting

Parameter	Value range	Default setting	Parameter reassignment in RUN	Scope
				HSP for STEP 7 (TIA Portal)
Potential group	<ul style="list-style-type: none"> Use the potential group of the left module (dark BaseUnit) Enable new potential group (light BaseUnit) 	Use the potential group of the left module (dark BaseUnit)	No	Module
Reaction to CPU STOP	<ul style="list-style-type: none"> Output substitute value Keep last value Continue operation 	Output substitute value	Yes	Channel
Enable diagnostic interrupt on wire break	<ul style="list-style-type: none"> Deactivated Activated 	Deactivated	Yes	Channel
Enable additional diagnostic interrupts	<ul style="list-style-type: none"> Deactivated Activated 	Deactivated	Yes	Channel
Hardware interrupt: New Capture value available	<ul style="list-style-type: none"> Deactivated Activated 	Deactivated	Yes	Channel
Hardware interrupt: Synchronization of the counter by an external signal	<ul style="list-style-type: none"> Deactivated Activated 	Deactivated	Yes	Channel
Hardware interrupt: Gate start	<ul style="list-style-type: none"> Deactivated Activated 	Deactivated	Yes	Channel
Hardware interrupt: Gate stop	<ul style="list-style-type: none"> Deactivated Activated 	Deactivated	Yes	Channel
Hardware interrupt: Overflow (high counting limit violated)	<ul style="list-style-type: none"> Deactivated Activated 	Deactivated	Yes	Channel
Hardware interrupt: Underflow (low counting limit violated)	<ul style="list-style-type: none"> Deactivated Activated 	Deactivated	Yes	Channel
Hardware interrupt: Direction reversal	<ul style="list-style-type: none"> Deactivated Activated 	Deactivated	Yes	Channel
Hardware interrupt: Zero crossing	<ul style="list-style-type: none"> Deactivated Activated 	Deactivated	Yes	Channel

4.1 Operating with "Counting and measurement" technology object

Parameter	Value range	Default setting	Parameter reassignment in RUN	Scope
				HSP for STEP 7 (TIA Portal)
Hardware interrupt: Comparison event for DQ0 occurred	<ul style="list-style-type: none"> • Deactivated • Activated 	Deactivated	Yes	Channel
Hardware interrupt: Comparison event for DQ1 occurred	<ul style="list-style-type: none"> • Deactivated • Activated 	Deactivated	Yes	Channel

The following parameter settings are possible in the technology object:

Table 4- 3 Settable parameters and their default setting

Parameter	Value range	Default setting	Parameter reassignment in RUN	Scope
				HSP for STEP 7 (TIA Portal)
Signal type	<ul style="list-style-type: none"> Pulse (A) Pulse (A) and direction (B) Count up (A), count down (B) Incremental encoder (A, B phase-shifted) Incremental encoder (A, B, N) 	Pulse (A) and direction (B)	Yes	Channel
Signal evaluation for counter inputs	<ul style="list-style-type: none"> Single Double Quadruple 	Single	Yes	Channel
Invert direction (counter inputs)	<ul style="list-style-type: none"> Deactivated Activated 	Deactivated	Yes	Channel
Filter frequency for counter inputs	<ul style="list-style-type: none"> 100 Hz 200 Hz 500 Hz 1 kHz 2 kHz 5 kHz 10 kHz 20 kHz 50 kHz 100 kHz 200 kHz 	200 kHz	Yes	Channel
Sensor type	<ul style="list-style-type: none"> Sourcing output Sinking output Push-pull (sinking and sourcing output) 	Sourcing output	Yes	Channel
Reaction to signal N	<ul style="list-style-type: none"> No reaction to signal N Synchronization at signal N Capture at signal N 	No reaction to signal N	Yes	Channel
Frequency of synchronization	<ul style="list-style-type: none"> Once Periodic 	Once	Yes	Channel
Frequency of Capture function	<ul style="list-style-type: none"> Once Periodic 	Once	Yes	Channel

4.1 Operating with "Counting and measurement" technology object

Parameter	Value range	Default setting	Parameter reassignment in RUN	Scope
				HSP for STEP 7 (TIA Portal)
Counting high limit	-2147483648...2147483647	2147483647	Yes	Channel
Start value	-2147483648...2147483647	0	Yes	Channel
Counting low limit	-2147483648...2147483647	-2147483648	Yes	Channel
Reaction to violation of a counting limit	<ul style="list-style-type: none"> Stop counting Continue counting 	Continue counting	Yes	Channel
Reset when counting limit is violated	<ul style="list-style-type: none"> To opposite counting limit To start value 	To opposite counting limit	Yes	Channel
Reaction to gate start	<ul style="list-style-type: none"> Set to start value Continue with current value 	Continue with current value	Yes	Channel
Set function of DI	<ul style="list-style-type: none"> Gate start/stop (level-triggered) Gate start (edge-triggered) Gate stop (edge-triggered) Synchronization Enable synchronization at signal N Capture Digital input without function 	<ul style="list-style-type: none"> DI0: Gate start/stop (level-triggered) DI1: Digital input without function DI2: Digital input without function 	Yes	Channel
Input delay for digital inputs	<ul style="list-style-type: none"> None 0.05 ms 0.1 ms 0.4 ms 0.8 ms 1.6 ms 3.2 ms 12.8 ms 20 ms 	0.1 ms	Yes	Channel
Edge selection for DI	<ul style="list-style-type: none"> At rising edge At falling edge At rising and falling edge 	At rising edge	Yes	Channel
Select level for DI	<ul style="list-style-type: none"> Active with high level Active with low level 	Active with high level	Yes	Channel
Behavior of counter value after Capture with DI	<ul style="list-style-type: none"> Continue counting Set to start value and continue counting 	Continue counting	Yes	Channel
Comparison value 0	-2147483648...2147483647	0	Yes	Channel
Comparison value 1	-2147483648...2147483647	10	Yes	Channel

4.1 Operating with "Counting and measurement" technology object

Parameter	Value range	Default setting	Parameter reassignment in RUN	Scope
				HSP for STEP 7 (TIA Portal)
Operating mode	<ul style="list-style-type: none"> Use count value as reference Use measured value as reference 	Use count value as reference	No	Channel
Set output	<ul style="list-style-type: none"> Use by user program Between comparison value and high limit / measured value \geq comparison value Between comparison value and low limit / measured value \leq comparison value At comparison value for a pulse duration After set command from CPU until comparison value Between comparison value 0 and 1 Not between comparison value 0 and 1 	DQ0, DQ1: Between comparison value and high limit	Yes	Channel
Count direction of DQ function	<ul style="list-style-type: none"> Up Down In both directions 	In both directions	Yes	Channel
Pulse duration [ms/10]	0...65535	5000 (corresponds to 0.5 s)	Yes	Channel
Substitute value for DQ0	<ul style="list-style-type: none"> 0 1 	0	Yes	Channel
Substitute value for DQ1	<ul style="list-style-type: none"> 0 1 	0	Yes	Channel
Hysteresis (in increments)	0...255	0	Yes	Channel
Measured variable	<ul style="list-style-type: none"> Frequency Period Velocity 	Frequency	Yes	Channel
Update time [ms] of measuring function	0...25000	10	Yes	Channel
Time base for velocity measurement	<ul style="list-style-type: none"> 1 ms 10 ms 100 ms 1 s 60 s 	60 s	Yes	Channel
Increments per unit	1...65535	1	Yes	Channel

4.1 Operating with "Counting and measurement" technology object

Explanation of parameters

You can find a detailed description of the parameters in function manual Counting, Measurement and Position Detection in sections Basic parameters and Configuring the High_Speed_Counter available for download on the Internet (<http://support.automation.siemens.com/WW/view/en/59709820>).

4.1.4 Address space

Address space of the technology module

Table 4- 4 Size of input and output addresses of the TM Count 1x24V when operating with "Counting and measurement" technology object

	Inputs	Outputs
Range	16 bytes	12 bytes

4.1.5 Isochronous mode

The technology module supports the "Isochronous mode" system function. This system function enables counter values and measured values to be acquired in a defined system cycle.

In isochronous mode, the cycle of the user program, the transmission of the input signals and processing in the technology module are synchronized. The output signals switch immediately if the relevant comparison condition is met. A status change of a digital input immediately triggers the specified reaction of the technology module and the change of the status bit of the digital input in the feedback interface.

Use an OB of type "Synchronous Cycle" (e.g. OB61) in this operating mode. The High_Speed_Counter instruction is called in the assigned OB.

The update time for the measured value is synchronized with the system cycle in a suitable ratio and, if necessary, adapted in length. If you set "0", the measured value is updated once per system cycle.

Data processing

The data that was transmitted to the technology module in the current bus cycle via the control interface takes effect when it is processed in the internal technology module cycle. At the time the input data is read in (T_i), the counter value and the measured value as well as status bits are acquired and made available in the feedback interface for retrieval in the current bus cycle.

Isochronous mode parameters

In isochronous mode, the "Filter frequency" parameter can affect the isochronous mode parameters of the sync domain.

Because the isochronous mode parameters are not checked in RUN, overflows can occur if you change the parameters in RUN. To prevent overflows, select the option with the largest time required in the offline parameter assignment.

Additional information

You can find a detailed description of isochronous mode in the following:

- Function manual Isochronous Mode (STEP 7 (TIA Portal) V15.1 or higher) available for download on the Internet (<https://support.industry.siemens.com/cs/ww/en/view/109755401>)
- Function manual PROFINET with STEP 7 available for download on the Internet (<https://support.industry.siemens.com/cs/ww/en/view/49948856>)

4.2 Position input for ""Motion Control"" technology object

4.2.1 Configuring

Introduction

You configure the technology module and assign its parameters with STEP 7 (TIA Portal).

The technology object is used to control and monitor the functions of the technology module.

System environment

The technology module can be used in the following system environments:

Applications	Components required	Configuration software	In the user program
Central operation with a CPU 151xSP	<ul style="list-style-type: none"> S7-1500 automation system TM Count 1x24V 	STEP 7 (TIA Portal):	Motion Control instructions
Distributed operation with an S7-1500 CPU	<ul style="list-style-type: none"> S7-1500 automation system ET 200SP distributed I/O system TM Count 1x24V 	<ul style="list-style-type: none"> Device configuration with hardware configuration Parameter setting with axis and measuring input technology objects 	

Additional information

You can find a detailed description of the use of Motion Control and its configuration in the following:

- Function manual S7-1500 Motion Control available for download on the Internet (<http://support.automation.siemens.com/WW/view/en/59381279>)
- Function manual S7-1500T Motion Control available for download on the Internet (<https://support.industry.siemens.com/cs/ww/en/view/109481326>)
- Information system of STEP 7 (TIA Portal) under "Using technology functions > Motion Control > Motion Control (S7-1200, S7-1500)"

You can find a description of configuring the technology module for position detection in the following:

- Function manual Counting, Measurement and Position Detection available for download on the Internet (<http://support.automation.siemens.com/WW/view/en/59709820>)
- Information system of STEP 7 (TIA Portal) under "Using technology functions > Counting, measurement and position input > Counting, measurement and position input (S7-1500)"

Hardware Support Packages (HSP)

If firmware version V1.3 of the module is not yet integrated in your TIA Portal Version V15, you can integrate a corresponding module using HSP0256.

You can find the Hardware Support Packages (HSP) for download on the Internet (<https://support.industry.siemens.com/cs/ww/en/view/72341852>).

You can also access this download from the menu bar of STEP 7 (TIA Portal): "Options > Support packages > Download from the Internet".

4.2.2 Parameter setting

You specify the properties of the technology module using various parameters. Depending on the settings, not all parameters are available.

You set the parameters of the module as follows in this operating mode:

1. Insert the module from the hardware catalog under "Technology modules".
2. Set the device configuration and the parameters of the module in the hardware configuration.
"Position input for "Motion Control" technology object" must be set as the operating mode.
3. Insert the axis technology object and, if necessary, the measuring input technology object from the project tree in folder "Technology objects > Add new object > Motion Control". You can find information on configuring with axis technology objects in function manual S7-1500T Motion Control (<https://support.industry.siemens.com/cs/ww/en/view/109481326>).
4. Open the configuration of the axis technology object, e.g. using the Configuration button  in the respective instruction for the technology object.
5. Set the parameters of the technology objects.
6. Download the project to the CPU.

Parameters of the TM Count 1x24V

The following parameter settings are possible:

Table 4- 5 Settable parameters and their default setting

Parameter	Value range	Default setting	Scope
			HSP for STEP 7 (TIA Portal)
Potential group	<ul style="list-style-type: none"> • Use the potential group of the left module (dark BaseUnit) • Enable new potential group (light BaseUnit) 	Use the potential group of the left module (dark BaseUnit)	Module
Signal type	<ul style="list-style-type: none"> • Pulse (A) • Pulse (A) and direction (B) • Count up (A), count down (B) • Incremental encoder (A, B phase-shifted) • Incremental encoder (A, B, N) 	Pulse (A) and direction (B)	Channel
Invert direction (counter inputs)	<ul style="list-style-type: none"> • Deactivated • Activated 	Deactivated	Channel
Signal evaluation for counter inputs	<ul style="list-style-type: none"> • Single • Double • Quadruple 	Single	Channel

Parameter	Value range	Default setting	Scope
			HSP for STEP 7 (TIA Portal)
Filter frequency for counter inputs	<ul style="list-style-type: none"> • 100 Hz • 200 Hz • 500 Hz • 1 kHz • 2 kHz • 5 kHz • 10 kHz • 20 kHz • 50 kHz • 100 kHz • 200 kHz 	200 kHz	Channel
Sensor type	<ul style="list-style-type: none"> • Sourcing output • Sinking output • Push-pull (sinking and sourcing output) 	Sourcing output	Channel
Signal selection for reference mark 0	<ul style="list-style-type: none"> • DI0 • Signal N of incremental encoder 	DI0	Channel
Measuring input	DI1	DI1	Channel
Increments per revolution / steps per revolution	1...65535	1	Channel
Reference speed	6.00...210000.00 U/min	3000.00 U/min	Channel
Enable diagnostic interrupt on wire break	<ul style="list-style-type: none"> • Deactivated • Activated 	Deactivated	Channel
Enable additional diagnostic interrupts	<ul style="list-style-type: none"> • Deactivated • Activated 	Deactivated	Channel

Explanation of parameters

You can find a detailed description of the parameters in function manual Counting, Measurement and Position Detection, section Module parameters (position input for Motion Control) available for download on the Internet (<http://support.automation.siemens.com/WW/view/en/59709820>).

4.2.3 Address space

Address space of the technology module

Table 4- 6 Size of input and output addresses of the TM Count 1x24V with position input for "Motion Control" technology object

	Inputs	Outputs
Range	16 bytes	4 bytes

4.2.4 Isochronous mode

The technology module supports the "Isochronous mode" system function. Counter values can be acquired in a fixed system cycle with this system function.

In isochronous mode, the cycle of the user program, the transmission of the input signals and processing in the technology module are synchronized. A status change of a digital input immediately triggers the specified reaction of the technology module and the change of the status bit of the digital input in the feedback interface.

Use an OB of type "MC-Servo" in this operating mode. Isochronous mode is needed when using the output cam and cam track technology objects. When the measuring input technology is used in combination with hardware digital input DI1, isochronous mode is not needed.

Data processing

The data that was transmitted to the technology module in the current bus cycle via the control interface takes effect when it is processed in the internal technology module cycle. At the time the input data is read (T_i), the counter value and the status bits are acquired and made available in the feedback interface for retrieval in the current bus cycle.

Isochronous mode parameters

In isochronous mode, the "Filter frequency" parameter can affect the isochronous mode parameters of the sync domain.

Because the isochronous mode parameters are not checked in RUN, overflows can occur if you change the parameters in RUN. To prevent overflows, select the option with the largest time required in the offline parameter assignment.

Additional information

You can find a detailed description of isochronous mode in the following:

- Function manual Isochronous Mode (STEP 7 (TIA Portal) V15.1 or higher) available for download on the Internet (<https://support.industry.siemens.com/cs/ww/en/view/109755401>)
- Function manual PROFINET with STEP 7 available for download on the Internet (<https://support.industry.siemens.com/cs/ww/en/view/49948856>)

4.3 Manual operation (without technology object)

4.3.1 Configuring

Introduction

You configure the technology module and assign its parameters with the configuration software.

The functions of the technology module are controlled and checked by the user program via the control and feedback interface.

System environment

The technology module can be used in the following system environments:

Applications	Components required	Configuration software	In the user program
Central operation with a CPU 151xSP	<ul style="list-style-type: none"> S7-1500 automation system TM Count 1x24V 	STEP 7 (TIA Portal): <ul style="list-style-type: none"> Device configuration and parameter setting with hardware configuration 	Direct access to control and feedback interface in the I/O data
Distributed operation with an S7-1500 CPU	<ul style="list-style-type: none"> S7-1500 automation system ET 200SP distributed I/O system TM Count 1x24V 	STEP 7 (TIA Portal): <ul style="list-style-type: none"> Device configuration and parameter setting with hardware configuration 	
Distributed operation with an S7-300/400 CPU	<ul style="list-style-type: none"> S7-300/400 or S7-1200 automation system ET 200SP distributed I/O system TM Count 1x24V 	STEP 7 (TIA Portal): Device configuration and parameter setting with hardware configuration STEP 7: Device configuration and parameter setting with HSP (up to firmware version V1.2) or GSD file	
Distributed operation with an S7-1200 CPU	<ul style="list-style-type: none"> S7-300/400 or S7-1200 automation system ET 200SP distributed I/O system TM Count 1x24V 	STEP 7 (TIA Portal): Device configuration and parameter setting with hardware configuration	
Distributed operation in a third-party system	<ul style="list-style-type: none"> Third-party automation system ET 200SP distributed I/O system TM Count 1x24V 	Third-party configuration software: Device configuration and parameter setting with GSD file	

Additional information

You can find a detailed description of the counting and measurement functions and their configuration in the following:

- Function manual Counting, Measurement and Position Detection available for download on the Internet (<http://support.automation.siemens.com/WW/view/en/59709820>)
- Information system of STEP 7 (TIA Portal) under "Using technology functions > Counting, measurement and position input > Counting, measurement and position input (S7-1500)"

Hardware Support Packages (HSP)

STEP 7 (TIA Portal)

If firmware version V1.3 of the module is not yet integrated in your TIA Portal Version V15, you can integrate a corresponding module using HSP0256.

You can find the Hardware Support Packages (HSP) for download on the Internet (<https://support.industry.siemens.com/cs/ww/en/view/72341852>).

You can also access this download from the menu bar of STEP 7 (TIA Portal): "Options > Support packages > Download from the Internet".

STEP 7

You can find the Hardware Support Packages (HSP) for download on the Internet (<https://support.industry.siemens.com/cs/ww/en/view/23183356>).

GSD file

You can find the respective GSD file for the ET 200SP distributed I/O system for download on the Internet:

- GSD file for PROFINET IO
(<http://support.automation.siemens.com/WW/view/en/57138621>)
- GSD file for PROFIBUS DP
(<http://support.automation.siemens.com/WW/view/en/73016883>)

4.3.2 Reaction to CPU STOP

You set the response of the technology module to CPU STOP for each channel in the basic parameters of the device configuration.

Table 4- 7 Response of technology module to CPU STOP

Option	Meaning
Continue operation	The technology module remains fully functional. Incoming count pulses are processed. The digital outputs continue to switch according to the parameter assignment.
Output substitute value	The technology module outputs the configured substitute values at the digital outputs until the next CPU STOP-RUN transition. The technology module is returned to its startup state after a STOP-RUN transition: The counter value is set to the start value and the digital outputs switch according to the parameter assignment.
Keep last value	The technology module outputs the values at the digital outputs that were valid when the transition to STOP took place until the next CPU STOP-RUN transition. If a digital output with the function "At comparison value for a pulse duration" is set at CPU stop, the digital output is reset after the pulse duration elapses. The technology module is returned to its startup state after a STOP-RUN transition: The counter value is set to the start value and the digital outputs switch according to the parameter assignment.

4.3.3 Parameter setting

You specify the properties of the technology module using various parameters. Depending on the settings, not all parameters are available. When parameters are assigned in the user program, the parameters are transferred to the module with the "WRREC" instruction and data record 128 (Page 91).

You set the parameters of the module as follows in this operating mode:

Parameter setting using...	Basic procedure
Hardware configuration in STEP 7 (TIA Portal)	<ol style="list-style-type: none"> 1. Insert the module from the hardware catalog under "Technology modules". 2. Set the device configuration and the parameters of the module in the hardware configuration. "Manual operation (without technology object)" must be set as the operating mode. 3. Download the project to the CPU.
Hardware configuration in STEP 7 with HSP	<ol style="list-style-type: none"> 1. Install the appropriate HSP file. You will then find the module in the hardware catalog under "ET 200SP". 2. Set the device configuration and the parameters in the hardware configuration. 3. Download the project to the CPU.
Hardware configuration with GSD file for distributed operation on PROFINET IO	<ol style="list-style-type: none"> 1. Install the current PROFINET GSD file. You will then find the module in the hardware catalog under "Other field devices > PROFINET IO > I/O". 2. Set the parameters in the hardware configuration. You can find information on the respective dependencies of the parameters in function manual Counting, Measurement and Position Detection (http://support.automation.siemens.com/WW/view/en/59709820). 3. Download the project to the CPU.
Hardware configuration with GSD file for distributed operation on PROFIBUS DP	<ol style="list-style-type: none"> 1. Install the current PROFIBUS GSD file. You will then find the module in the hardware catalog under "Other field devices > PROFIBUS DP > I/O". 2. Set the parameters in the hardware configuration. You can find information on the respective dependencies of the parameters in function manual Counting, Measurement and Position Detection (http://support.automation.siemens.com/WW/view/en/59709820). The parameters marked with ¹ in the following tables are not configurable in the PROFIBUS GSD file. 3. Download the project to the CPU. The parameters marked with ¹ in the following tables are downloaded with their default setting. 4. If necessary, set the parameters marked with ¹ in the user program using data record 128.

Parameters of the TM Count 1x24V

The following parameter settings are possible:

Table 4- 8 Settable parameters and their default setting

Parameter	Value range	Default setting	Parameter reassignment in RUN	Scope
				HSP for STEP 7 (TIA Portal); HSP for STEP 7; GSD file
Potential group	<ul style="list-style-type: none"> Use the potential group of the left module (dark BaseUnit) Enable new potential group (light BaseUnit) 	Use the potential group of the left module (dark BaseUnit)	No	Module
Operating mode ³	<ul style="list-style-type: none"> Counting Measuring 	Counting	No	Channel
Reaction to CPU STOP ¹	<ul style="list-style-type: none"> Output substitute value Keep last value Continue operation 	Output substitute value	Yes	Channel
Substitute value for DQ0 ¹	<ul style="list-style-type: none"> 0 1 	0	Yes	Channel
Substitute value for DQ1 ¹	<ul style="list-style-type: none"> 0 1 	0	Yes	Channel
Enable diagnostic interrupt on wire break ²	<ul style="list-style-type: none"> Deactivated Activated 	Deactivated	Yes	Channel
Enable additional diagnostic interrupts	<ul style="list-style-type: none"> Deactivated Activated 	Deactivated	Yes	Channel
Hardware interrupt: New Capture value available ¹	<ul style="list-style-type: none"> Deactivated Activated 	Deactivated	Yes	Channel
Hardware interrupt: Synchronization of the counter by an external signal ¹	<ul style="list-style-type: none"> Deactivated Activated 	Deactivated	Yes	Channel
Hardware interrupt: Gate start ¹	<ul style="list-style-type: none"> Deactivated Activated 	Deactivated	Yes	Channel
Hardware interrupt: Gate stop ¹	<ul style="list-style-type: none"> Deactivated Activated 	Deactivated	Yes	Channel
Hardware interrupt: Overflow (high counting limit violated) ¹	<ul style="list-style-type: none"> Deactivated Activated 	Deactivated	Yes	Channel
Hardware interrupt: Underflow (low counting limit violated) ¹	<ul style="list-style-type: none"> Deactivated Activated 	Deactivated	Yes	Channel

Parameter	Value range	Default setting	Parameter reassignment in RUN	Scope
				HSP for STEP 7 (TIA Portal); HSP for STEP 7; GSD file
Hardware interrupt: Direction reversal ¹	<ul style="list-style-type: none"> Deactivated Activated 	Deactivated	Yes	Channel
Hardware interrupt: Zero crossing ¹	<ul style="list-style-type: none"> Deactivated Activated 	Deactivated	Yes	Channel
Hardware interrupt: Comparison event for DQ0 occurred ¹	<ul style="list-style-type: none"> Deactivated Activated 	Deactivated	Yes	Channel
Hardware interrupt: Comparison event for DQ1 occurred ¹	<ul style="list-style-type: none"> Deactivated Activated 	Deactivated	Yes	Channel
Signal type	<ul style="list-style-type: none"> Pulse (A) Pulse (A) and direction (B) Count up (A), count down (B) Incremental encoder (A, B phase-shifted) Incremental encoder (A, B, N) 	Pulse (A) and direction (B)	Yes	Channel
Invert direction ¹ (counter inputs)	<ul style="list-style-type: none"> Deactivated Activated 	Deactivated	Yes	Channel
Signal evaluation for counter inputs	<ul style="list-style-type: none"> Single Double Quadruple 	Single	Yes	Channel
Filter frequency for counter inputs ¹	<ul style="list-style-type: none"> 100 Hz 200 Hz 500 Hz 1 kHz 2 kHz 5 kHz 10 kHz 20 kHz 50 kHz 100 kHz 200 kHz 	200 kHz	Yes	Channel
Sensor type	<ul style="list-style-type: none"> Sourcing output Sinking output Push-pull (sinking and sourcing output) 	Sourcing output	Yes	Channel

4.3 Manual operation (without technology object)

Parameter	Value range	Default setting	Parameter reassignment in RUN	Scope
				HSP for STEP 7 (TIA Portal); HSP for STEP 7; GSD file
Reaction to signal N ¹	<ul style="list-style-type: none"> No reaction to signal N Synchronization at signal N Capture at signal N 	No reaction to signal N	Yes	Channel
Frequency of synchronization ¹	<ul style="list-style-type: none"> Once Periodic 	Once	Yes	Channel
Frequency of Capture function ^{1,4}	<ul style="list-style-type: none"> Once Periodic 	Once	Yes	Channel
High counting limit ¹	-2147483648...2147483647	2147483647	Yes	Channel
Start value ¹	-2147483648...2147483647	0	Yes	Channel
Counting low limit ¹	-2147483648...2147483647	-2147483648	Yes	Channel
Reaction to violation of a counting limit	<ul style="list-style-type: none"> Stop counting Continue counting 	Continue counting	Yes	Channel
Reset when counting limit is violated	<ul style="list-style-type: none"> To opposite counting limit To start value 	To opposite counting limit	Yes	Channel
Reaction to gate start	<ul style="list-style-type: none"> Set to start value Continue with current value 	Continue with current value	Yes	Channel
Set function of DI	<ul style="list-style-type: none"> Gate start/stop (level-triggered) Gate start (edge-triggered) Gate stop (edge-triggered) Synchronization Enable synchronization at signal N Capture Digital input without function 	<ul style="list-style-type: none"> DI0: Gate start/stop (level-triggered) DI1: Digital input without function DI2: Digital input without function 	Yes	Channel
Select level for DI ¹	<ul style="list-style-type: none"> Active with high level Active with low level 	Active with high level	Yes	Channel
Edge selection for DI ¹	<ul style="list-style-type: none"> At rising edge At falling edge At rising and falling edge 	At rising edge	Yes	Channel
Behavior of counter value after Capture with DI ¹	<ul style="list-style-type: none"> Continue counting Set to start value and continue counting 	Continue counting	Yes	Channel

Parameter	Value range	Default setting	Parameter reassignment in RUN	Scope
				HSP for STEP 7 (TIA Portal); HSP for STEP 7; GSD file
Input delay for digital inputs ¹	<ul style="list-style-type: none"> None 0.05 ms 0.1 ms 0.4 ms 0.8 ms 1.6 ms 3.2 ms 12.8 ms 20 ms 	0.1 ms	Yes	Channel
Set output	<ul style="list-style-type: none"> Use by user program Between comparison value and high limit / measured value \geq comparison value Between comparison value and low limit / measured value \leq comparison value At comparison value for a pulse duration After set command from CPU until comparison value Between comparison value 0 and 1 Not between comparison value 0 and 1 	DQ0, DQ1: Between comparison value and high limit	Yes	Channel
Comparison value 0 ¹	-2147483648...2147483647	0	Yes	Channel
Comparison value 1 ¹	-2147483648...2147483647	10	Yes	Channel
Count direction of DQ function ¹	<ul style="list-style-type: none"> Up Down In both directions 	In both directions	Yes	Channel
Pulse duration [ms/10] ¹	0...65535	5000 (corresponds to 0.5 s)	Yes	Channel
Hysteresis (in increments) ¹	0...255	0	Yes	Channel
Measured variable	<ul style="list-style-type: none"> Frequency Period Velocity 	Frequency	Yes	Channel
Update time [ms] of the measuring function ¹	0...25000	10	Yes	Channel

4.3 Manual operation (without technology object)

Parameter	Value range	Default setting	Parameter reassignment in RUN	Scope
				HSP for STEP 7 (TIA Portal); HSP for STEP 7; GSD file
Time base for velocity measurement ¹	<ul style="list-style-type: none"> • 1 ms • 10 ms • 100 ms • 1 s • 60 s 	60 s	Yes	Channel
Increments per unit ¹	1...65535	1	Yes	Channel

- ¹ Because the number of parameters is limited to a maximum of 244 bytes per station in the PROFIBUS GSD configuration, the possible parameter assignments are limited. The parameters are preassigned default settings in the module. If your PROFIBUS master supports the "Write/read data record" function, you can set these parameters using data record 128.
- ² When a GSD file is used, this diagnostic interrupt is enabled with the "Enable additional diagnostic interrupts" parameter and is then not separately configurable.
- ³ When configuring with HSP for STEP 7 or with a GSD file, you determine the operating mode when you select the module name.
- ⁴ Not available with HSP for STEP 7

Explanation of parameters

You can find a detailed description of the parameters in function manual Counting, Measurement and Position Detection, sections Basic parameters and Manual operation available for download on the Internet (<http://support.automation.siemens.com/WW/view/en/59709820>).

4.3.4 Address space

Address space of the technology module

Table 4- 9 Size of input and output addresses of the TM Count 1x24V with manual operation

	Inputs	Outputs
Range	16 bytes	12 bytes

4.3.5 Control and feedback interface

Note

The control and feedback interface is compatible with the control and feedback interface of the TM Count 2x24V, TM PosInput 2 and TM PosInput 1 technology modules of the S7-1500 automation system.

4.3.5.1 Assignment of the control interface

The user program uses the control interface to influence the behavior of the technology module.

Control interface

The following table shows the assignment of the control interface:

Byte offset from start address ↓	Bit 7	Bit 6	Bit 5	Bit 4	Bit 3	Bit 2	Bit 1	Bit 0
0...3	SLOT_0: DINT or REAL: Load value (meaning of the value is specified in LD_SLOT_0) Value range: -2147483648 to 2147483647 _D or 80000000 to 7FFFFFFF _H							
4...7	SLOT_1: DINT or REAL: Load value (meaning of the value is specified in LD_SLOT_1) Value range: -2147483648 to 2147483647 _D or 80000000 to 7FFFFFFF _H							
8	LD_SLOT_1				LD_SLOT_0			
9	EN_CAPTURE	EN_SYNC_DN	EN_SYNC_UP	SET_DQ1	SET_DQ0	TM_CTRL_DQ1	TM_CTRL_DQ0	SW_GATE

4.3 Manual operation (without technology object)

Byte offset from start address ↓	Bit 7	Bit 6	Bit 5	Bit 4	Bit 3	Bit 2	Bit 1	Bit 0
10	SET_DIR	Reserved					RES_EVENT	RES_ERROR
11	Reserved							

Explanations

Control bit/value	Explanations
EN_CAPTURE	Use this bit to enable the Capture function. Resetting this bit resets a set EVENT_CAP in the feedback interface.
EN_SYNC_DN	Use this bit to enable the synchronization of the counter when counting in downward direction with an incremental encoder or pulse encoder. Resetting this bit resets a set EVENT_SYNC in the feedback interface.
EN_SYNC_UP	Use this bit to enable the synchronization of the counter when counting in upward direction with an incremental encoder or pulse encoder. Resetting this bit resets a set EVENT_SYNC in the feedback interface.
LD_SLOT_m	<p>Use this load request to specify the meaning of the value in SLOT_m:</p> <ul style="list-style-type: none"> • 0000 means: No action, idle • 0001 means: Load counter value • 0010 not permitted • 0011 means: Load start value • 0100 means: Load comparison value 0 • 0101 means: Load comparison value 1 • 0110 means: Load counting low limit • 0111 means: Load counting high limit • 1000 to 1111 not permitted <p>The technology module executes the respective action as soon as LD_SLOT_m changes. If values are loaded simultaneously using LD_SLOT_0 and LD_SLOT_1, the value from SLOT_0 is internally applied first and then the value from SLOT_1 . This can produce unexpected intermediate states.</p>
RES_EVENT	Use this bit to trigger the reset of the saved events in the EVENT_ZERO, EVENT_OFLW, EVENT_UFLW, EVENT_CMP0, EVENT_CMP1 feedback bits.
RES_ERROR	Use this bit to trigger the reset of the saved error states LD_ERROR and ENC_ERROR .
Reserved	Reserve bits must be set to 0.
SET_DIR	<p>Use this bit to specify the count direction for signal type "Pulse (A)".</p> <ul style="list-style-type: none"> • 0 means: Up • 1 means: Down
SET_DQ0	<p>Use this bit to set digital output DQ0 when TM_CTRL_DQ0 is set to 0.</p> <p>In the case of the function "After set command from CPU until comparison value", SET_DQ0 is effective regardless of TM_CTRL_DQ0 as long as the counter value is not equal to the comparison value.</p>

Control bit/value	Explanations
SET_DQ1	<p>Use this bit to set digital output DQ1 when TM_CTRL_DQ1 is set to 0.</p> <p>In the case of the function "After set command from CPU until comparison value", SET_DQ1 is effective regardless of TM_CTRL_DQ1 as long as the counter value is not equal to the comparison value.</p>
SW_GATE	<p>Use this bit to open and close the software gate when using an incremental encoder or pulse encoder. Together, the software gate and the hardware gate form the internal gate. The technology module only counts when the internal gate is open.</p> <ul style="list-style-type: none"> • 0 means: Software gate closed • 1 means: Software gate open <p>The digital inputs of the technology module externally control the hardware gate. The hardware gate can be activated by parameter assignment. The software gate cannot be deactivated.</p>
TM_CTRL_DQ0	<p>Use this bit to enable the technological function of digital output DQ0.</p> <ul style="list-style-type: none"> • 0 means: SET_DQ0 defines the state of DQ0 • 1 means: assigned function defines the state of DQ0
TM_CTRL_DQ1	<p>Use this bit to enable the technological function of digital output DQ1.</p> <ul style="list-style-type: none"> • 0 means: SET_DQ1 defines the state of DQ1 • 1 means: assigned function defines the state of DQ1

4.3.5.2 Assignment of the feedback interface

The user program receives current values and status information from the technology module by means of the feedback interface.

Feedback interface

The following table shows the assignment of the feedback interface:

Byte offset from start address ↓	Bit 7	Bit 6	Bit 5	Bit 4	Bit 3	Bit 2	Bit 1	Bit 0
0...3	COUNT_VALUE: DINT: Current counter value							
4...7	CAPTURED_VALUE: DINT: The last acquired Capture value							
8...11	MEASURED_VALUE: REAL: Current measured value							
12	Reserved					LD_ERROR	ENC_ERROR	POWER_ERROR
13	Reserved		STS_SW_GATE	STS_READY	LD_STS_SLOT_1	LD_STS_SL_OT_0	RES_EVENT_ACK	Reserved
14	STS_DI2	STS_DI1	STS_DI0	STS_DQ1	STS_DQ0	STS_GATE	STS_CNT	STS_DIR
15	STS_M_INTERVAL	EVENT_CAP	EVENT_SYNC	EVENT_CMP1	EVENT_CMP0	EVENT_OFLW	EVENT_UFLW	EVENT_ZERO

Explanations

Feedback bit/value	Explanations
CAPTURED_VALUE	<p>This DINT value indicates the last acquired Capture value.</p> <p>The following external signals can trigger the Capture function:</p> <ul style="list-style-type: none"> • Rising or falling edge of a digital input • Both edges of a digital input <p>The "Frequency of Capture function" parameter specifies whether the function is executed at each configured edge or only once after each enable.</p>
COUNT_VALUE	This DINT value indicates the current counter value.
ENC_ERROR	<p>This bit indicates that one of the following errors has occurred at the encoder signals (retentive) for the respective technology module:</p> <ul style="list-style-type: none"> • Wire break of digital input A, B or N (with push-pull encoder) • Invalid transition of A/B signals (with incremental encoder) <p>If you have enabled the diagnostic interrupts, the respective diagnostic interrupt is triggered in the event of encoder signal errors. For information on the meaning of the diagnostic interrupts, refer to the manual for the respective technology module.</p> <p>The bit is reset once you have acknowledged the error with RES_ERROR .</p>
EVENT_CAP	This bit indicates that a Capture event has occurred and a counter value has been saved in CAPTURED_VALUE . You reset the status by resetting EN_CAPTURE .
EVENT_CMP0	<p>This bit indicates the saved status that a comparison event (status change) has occurred for the digital output DQ0 based on the selected comparison condition. You reset the status by acknowledgment with RES_EVENT.</p> <p>If the counter value is set to the start value in counting mode, EVENT_CMP0 is not set.</p>
EVENT_CMP1	<p>This bit indicates the saved status that a comparison event (status change) has occurred for the digital output DQ1 based on the selected comparison condition. You reset the status by acknowledgment with RES_EVENT.</p> <p>If the counter value is set to the start value in counting mode, EVENT_CMP1 is not set.</p>
EVENT_OFLW	This bit indicates the saved status that the counter value had an overflow. You reset the status by acknowledgment with RES_EVENT.
EVENT_SYNC	When an incremental or pulse encoder is used, this bit indicates the saved status that the counter was loaded with the start value by an external reference signal (synchronization). You reset the status by resetting EN_SYNC_UP or EN_SYNC_DN .
EVENT_UFLW	This bit indicates the saved status that the counter value had an underflow. You reset the status by acknowledgment with RES_EVENT.
EVENT_ZERO	<p>This bit indicates the saved status that the counter value or position value had a zero crossing. You reset the status by acknowledgment with RES_EVENT.</p> <p>When the "Zero crossing" hardware interrupt is enabled, for system-related reasons it can also be triggered if "0" is outside the configured value range.</p>
LD_ERROR	<p>This bit indicates that an error occurred (latching) during loading via the control interface. The loaded values were not applied. When using an incremental or pulse encoder, one of the following conditions is not fulfilled:</p> <ul style="list-style-type: none"> • Low counting limit <= counter value <= high counting limit • Low counting limit <= start value <= high counting limit • Low counting limit <= comparison value 0/1 <= high counting limit <p>The bit is reset once you have acknowledged the error with RES_ERROR .</p>
LD_STS_SLOT_0	This bit indicates by a status change (toggling) that the load request for SLOT_0 (LD_SLOT_0) was detected and performed.

4.3 Manual operation (without technology object)

Feedback bit/value	Explanations
LD_STS_SLOT_1	This bit indicates by a status change (toggling) that the load request for SLOT_1 (LD_SLOT_1) was detected and performed.
MEASURED_VALUE	<p>This value indicates the current measured value with data type REAL:</p> <ul style="list-style-type: none"> • Frequency: The mean frequency is calculated from the time profile of the count pulses or position value changes in one measurement interval and returned as a floating-point number in the unit of hertz. • Period: The mean period is calculated from the time profile of the count pulses or position value changes in one measurement interval and returned as a floating-point number in the unit of seconds. • Velocity: The mean velocity is calculated from the time profile of the count pulses or position value changes in one measurement interval and returned as a floating-point number in the configured unit. <p>The measured values are returned as a signed value. The sign indicates whether the counter value went up or down in the relevant time interval.</p> <p>The update time is asynchronous to the opening of the internal gate, i.e. the update time is not started when the gate opens. After the internal gate closes, the last calculated measured value continues to be returned.</p>
POWER_ERROR	This bit indicates that supply voltage L+ is too low. If you have enabled the diagnostic interrupts (Page 77), the diagnostics interrupt "Supply voltage missing" is triggered at a supply voltage error. When supply voltage L+ is available at a sufficient level once again, POWER_ERROR is automatically set to 0.
RES_EVENT_ACK	This bit indicates that the reset of event bit EVENT_SYNC, EVENT_CMP0, EVENT_CMP1, EVENT_OFLW, EVENT_UFLW, EVENT_ZERO is active.
Reserved	Reserved bits are set to 0.
STS_CNT	This bit indicates that at least one count pulse or a position value change has occurred in the last ca. 0.5 s.
STS_DI0	This bit indicates the status of digital input DI0.
STS_DI1	This bit indicates the status of digital input DI1.
STS_DI2	This bit indicates the status of digital input DI2.
STS_DIR	<p>This bit indicates the count direction of the last count pulse or the direction of the last position value change.</p> <ul style="list-style-type: none"> • 0 means: Down • 1 means: Up
STS_DQ0	This bit indicates the status of digital output DQ0.
STS_DQ1	This bit indicates the status of digital output DQ1.
STS_GATE	<p>This bit indicates the status of the internal gate when using an incremental or pulse encoder.</p> <ul style="list-style-type: none"> • 0 means: Gate closed • 1 means: Gate open
STS_M_INTERVAL	This bit indicates that at least one count pulse or a position value change was detected in the previous measurement interval.
STS_READY	This bit indicates that the technology module supplies valid user data. The technology module has been started up and configured.
STS_SW_GATE	<p>This bit indicates the status of the software gate.</p> <ul style="list-style-type: none"> • 0 means: Gate closed • 1 means: Gate open

4.3.6 Isochronous mode

The technology module supports the "Isochronous mode" system function. This system function enables counter values and measured values to be acquired in a defined system cycle.

In isochronous mode, the cycle of the user program, the transmission of the input signals and processing in the technology module are synchronized. The output signals switch immediately if the relevant comparison condition is met. A status change of a digital input immediately triggers the specified reaction of the technology module and the change of the status bit of the digital input in the feedback interface.

Use an OB of type "Synchronous Cycle" (e.g. OB61) in this operating mode. The input and output data are processed in the assigned OB.

The update time for the measured value is synchronized with the system cycle in a suitable ratio and, if necessary, adapted in length. If you set "0", the measured value is updated once per system cycle.

Data processing

The data that was transmitted to the technology module in the current bus cycle via the control interface takes effect when it is processed in the internal technology module cycle. At the time the input data is read in (T_i), the counter value and the measured value as well as status bits are acquired and made available in the feedback interface for retrieval in the current bus cycle.

Isochronous mode parameters

In isochronous mode, the "Filter frequency" parameter can affect the isochronous mode parameters of the sync domain.

Because the isochronous mode parameters are not checked in RUN, overflows can occur if you change the parameters in RUN. To prevent overflows, select the option with the largest time required in the offline parameter assignment.

Additional information

You can find a detailed description of isochronous mode in the following:

- Function manual Isochronous Mode (STEP 7 (TIA Portal) V15.1 or higher) available for download on the Internet (<https://support.industry.siemens.com/cs/ww/en/view/109755401>)
- Function manual PROFINET with STEP 7 available for download on the Internet (<https://support.industry.siemens.com/cs/ww/en/view/49948856>)

4.4 Fast Mode

You can use the technology module in Fast Mode for very fast acquisition of the counter value with compressed functionality. A reduced feedback interface but no control interface is available in Fast Mode. This allows you to use a shorter send clock for the CPU.

The scope of functions of the technology module has the following additional restrictions in Fast Mode:

- Parameter change in RUN only possible with data record 128
- Count/position value range: 25 bits
- No measured value available
- No software gate available
- No Capture function available
- No hardware interrupts available
- Combined error message (feedback bit) that is acknowledged automatically

4.4.1 Configuring

Introduction

You configure the technology module and assign its parameters with the configuration software.

The functions of the technology module are controlled and checked by the user program via the feedback interface.

System environment

The technology module can be used in the following system environments:

Applications	Components required	Configuration software	In the user program
Central operation with a CPU 151xSP	<ul style="list-style-type: none"> S7-1500 automation system TM Count 1x24V 	STEP 7 (TIA Portal): <ul style="list-style-type: none"> Device configuration and parameter setting with hardware configuration 	Direct access to feedback interface in the I/O data
Distributed operation with an S7-1500 CPU	<ul style="list-style-type: none"> S7-1500 automation system ET 200SP distributed I/O system TM Count 1x24V 	STEP 7 (TIA Portal): <ul style="list-style-type: none"> Device configuration and parameter setting with hardware configuration 	
Distributed operation with an S7-300/400 CPU	<ul style="list-style-type: none"> S7-300/400 or S7-1200 automation system ET 200SP distributed I/O system TM Count 1x24V 	STEP 7 (TIA Portal): Device configuration and parameter setting with hardware configuration STEP 7: Device configuration and parameter setting with HSP (up to firmware version V1.2) or GSD file	
Distributed operation with an S7-1200 CPU	<ul style="list-style-type: none"> S7-300/400 or S7-1200 automation system ET 200SP distributed I/O system TM Count 1x24V 	STEP 7 (TIA Portal): Device configuration and parameter setting with hardware configuration	
Distributed operation in a third-party system	<ul style="list-style-type: none"> Third-party automation system ET 200SP distributed I/O system TM Count 1x24V 	Third-party configuration software: Device configuration and parameter setting with GSD file	

Additional information

You can find a detailed description of the counting and measurement functions and their configuration in the following:

- Function manual Counting, Measurement and Position Detection available for download on the Internet (<http://support.automation.siemens.com/WW/view/en/59709820>)
- Information system of STEP 7 (TIA Portal) under "Using technology functions > Counting, measurement and position input > Counting, measurement and position input (S7-1500)"

Hardware Support Packages (HSP)

STEP 7 (TIA Portal)

If firmware version V1.3 of the module is not yet integrated in your TIA Portal Version V15, you can integrate a corresponding module using HSP0256.

You can find the Hardware Support Packages (HSP) for download on the Internet (<https://support.industry.siemens.com/cs/ww/en/view/72341852>).

You can also access this download from the menu bar of STEP 7 (TIA Portal): "Options > Support packages > Download from the Internet".

STEP 7

You can find the Hardware Support Packages (HSP) for download on the Internet (<https://support.industry.siemens.com/cs/ww/en/view/23183356>).

GSD file

You can find the respective GSD file for the ET 200SP distributed I/O system for download on the Internet:

- GSD file for PROFINET IO (<http://support.automation.siemens.com/WW/view/en/57138621>)
- GSD file for PROFIBUS DP (<http://support.automation.siemens.com/WW/view/en/73016883>)

4.4.2 Reaction to CPU STOP

You set the response of the technology module to CPU STOP for each channel in the basic parameters of the device configuration.

Table 4- 10 Response of technology module to CPU STOP

Option	Meaning
Continue operation	The technology module remains fully functional. Incoming count pulses are processed. The digital outputs continue to switch according to the parameter assignment.
Output substitute value	The technology module outputs the configured substitute values at the digital outputs until the next CPU STOP-RUN transition. The technology module is returned to its startup state after a STOP-RUN transition: The counter value is set to the start value and the digital outputs switch according to the parameter assignment.
Keep last value	The technology module outputs the values at the digital outputs that were valid when the transition to STOP took place until the next CPU STOP-RUN transition. If a digital output with the function "At comparison value for a pulse duration" is set at CPU stop, the digital output is reset after the pulse duration elapses. The technology module is returned to its startup state after a STOP-RUN transition: The counter value is set to the start value and the digital outputs switch according to the parameter assignment.

4.4.3 Parameter setting

You specify the properties of the technology module using various parameters. Depending on the settings, not all parameters are available. When parameters are assigned in the user program, the parameters are transferred to the module with the "WRREC" instruction and data record 128 (Page 91).

You set the parameters of the module as follows in this operating mode:

Parameter setting using...	Basic procedure
Hardware configuration in STEP 7 (TIA Portal)	<ol style="list-style-type: none"> 1. Insert the module from the hardware catalog under "Technology modules". 2. Set the device configuration and the parameters of the module in the hardware configuration. "Fast Mode" must be set as the operating mode. 3. Download the project to the CPU.
Hardware configuration in STEP 7 with HSP	<ol style="list-style-type: none"> 1. Install the appropriate HSP file. You will then find the module in the hardware catalog under "ET 200SP". 2. Set the device configuration and the parameters in the hardware configuration. 3. Download the project to the CPU.

4.4 Fast Mode

Parameter setting using...	Basic procedure
Hardware configuration with GSD file for distributed operation on PROFINET IO	<ol style="list-style-type: none"> 1. Install the current PROFINET GSD file. You will then find the module in the hardware catalog under "Other field devices > PROFINET IO > I/O". 2. Set the parameters in the hardware configuration. 3. Download the project to the CPU.
Hardware configuration with GSD file for distributed operation on PROFIBUS DP	<ol style="list-style-type: none"> 1. Install the current PROFIBUS GSD file. You will then find the module in the hardware catalog under "Other field devices > PROFIBUS DP > I/O". 2. Set the parameters in the hardware configuration. The parameters marked with ¹ in the following tables are not configurable in the PROFIBUS GSD file. 3. Download the project to the CPU. The parameters marked with ¹ in the following tables are downloaded with their default setting. 4. If necessary, set the parameters marked with ¹ in the user program using data record 128.

Parameters of the TM Count 1x24V

The following parameter settings are possible:

Table 4- 11 Settable parameters and their default setting

Parameter	Value range	Default setting	Parameter reassignment in RUN	Scope
				HSP for STEP 7 (TIA Portal); HSP for STEP 7; GSD file
Potential group	<ul style="list-style-type: none"> • Use the potential group of the left module (dark BaseUnit) • Enable new potential group (light BaseUnit) 	Use the potential group of the left module (dark BaseUnit)	No	Module
Reaction to CPU STOP ¹	<ul style="list-style-type: none"> • Output substitute value • Keep last value • Continue operation 	Output substitute value	Yes	Channel
Substitute value for DQ0 ¹	<ul style="list-style-type: none"> • 0 • 1 	0	Yes	Channel
Substitute value for DQ1 ¹	<ul style="list-style-type: none"> • 0 • 1 	0	Yes	Channel
Enable diagnostic interrupt on wire break ²	<ul style="list-style-type: none"> • Deactivated • Activated 	Deactivated	Yes	Channel
Enable additional diagnostic interrupts	<ul style="list-style-type: none"> • Deactivated • Activated 	Deactivated	Yes	Channel

Parameter	Value range	Default setting	Parameter reassignment in RUN	Scope
				HSP for STEP 7 (TIA Portal); HSP for STEP 7; GSD file
Signal type	<ul style="list-style-type: none"> Pulse (A) Pulse (A) and direction (B) Count up (A), count down (B) Incremental encoder (A, B phase-shifted) Incremental encoder (A, B, N) 	Pulse (A) and direction (B)	Yes	Channel
Invert direction ¹ (counter inputs)	<ul style="list-style-type: none"> Deactivated Activated 	Deactivated	Yes	Channel
Signal evaluation for counter inputs	<ul style="list-style-type: none"> Single Double Quadruple 	Single	Yes	Channel
Filter frequency for counter inputs ¹	<ul style="list-style-type: none"> 100 Hz 200 Hz 500 Hz 1 kHz 2 kHz 5 kHz 10 kHz 20 kHz 50 kHz 100 kHz 200 kHz 	200 kHz	Yes	Channel
Sensor type	<ul style="list-style-type: none"> Sourcing output Sinking output Push-pull (sinking and sourcing output) 	Sourcing output	Yes	Channel
Reaction to signal N ¹	<ul style="list-style-type: none"> No reaction to signal N Synchronization at signal N 	No reaction to signal N	Yes	Channel
Counting high limit ¹	1...33554431	33554431	Yes	Channel
Start value ¹	0...33554431	0	Yes	Channel
Counting low limit ¹	0...33554430	0	Yes	Channel
Reaction to violation of a counting limit	<ul style="list-style-type: none"> Stop counting Continue counting 	Continue counting	Yes	Channel
Reset when counting limit is violated	<ul style="list-style-type: none"> To opposite counting limit To start value 	To opposite counting limit	Yes	Channel

4.4 Fast Mode

Parameter	Value range	Default setting	Parameter reassignment in RUN	Scope
				HSP for STEP 7 (TIA Portal); HSP for STEP 7; GSD file
Reaction to gate start	<ul style="list-style-type: none"> Set to start value Continue with current value 	Continue with current value	Yes	Channel
Set function of DI	<ul style="list-style-type: none"> Gate start/stop (level-triggered) Gate start (edge-triggered) Gate stop (edge-triggered) Synchronization Enable synchronization at signal N Digital input without function 	Digital input without function	Yes	Channel
Input delay for digital inputs ¹	<ul style="list-style-type: none"> None 0.05 ms 0.1 ms 0.4 ms 0.8 ms 1.6 ms 3.2 ms 12.8 ms 20 ms 	0.1 ms	Yes	Channel
Select level for DI ¹	<ul style="list-style-type: none"> Active with high level Active with low level 	Active with high level	Yes	Channel
Edge selection for DI ¹	<ul style="list-style-type: none"> At rising edge At falling edge 	At rising edge	Yes	Channel
Frequency of synchronization ¹	<ul style="list-style-type: none"> Once Periodic 	Once	Yes	Channel
Count direction for synchronization	<ul style="list-style-type: none"> Up Down In both directions 	Up	Yes	Channel
Set output	<ul style="list-style-type: none"> Between comparison value and high limit Between comparison value and low limit At comparison value for a pulse duration Between comparison value 0 and 1 Digital output without function 	DQ0, DQ1: Digital output without function	Yes	Channel
Comparison value 0 ¹	0...33554431	0	Yes	Channel

Parameter	Value range	Default setting	Parameter reassignment in RUN	Scope
				HSP for STEP 7 (TIA Portal); HSP for STEP 7; GSD file
Comparison value 1 ¹	0...33554431	10	Yes	Channel
Count direction of DQ function ¹	<ul style="list-style-type: none"> • Up • Down • In both directions 	In both directions	Yes	Channel
Pulse duration [ms/10] ¹	0...65535	5000 (corresponds to 0.5 s)	Yes	Channel
Hysteresis (in increments) ¹	0...255	0	Yes	Channel

- ¹ Because the number of parameters is limited to a maximum of 244 bytes per station in the PROFIBUS GSD configuration, the possible parameter assignments are limited. The parameters are preassigned default settings in the module. If your PROFIBUS master supports the "Write/read data record" function, you can set these parameters using data record 128.
- ² When a GSD file is used, this diagnostic interrupt is enabled with the "Enable additional diagnostic interrupts" parameter and is then not separately configurable.

4.4.4 Explanation of parameters

Potential group

A potential group consists of a group of directly adjacent I/O modules within an ET 200SP station that are supplied from a common supply voltage.

A potential group begins with a light BaseUnit, which feeds the required supply voltage for all modules of the potential group. The light BaseUnit interrupts the three self-configuring voltage bars P1, P2 and AUX to the neighboring modules on the left.

All other I/O modules of this potential group are plugged into dark BaseUnits. They take on the potentials of the self-configuring busbars P1, P2 and AUX from the neighboring modules on the left.

A potential group ends with the dark BaseUnit, which is followed by a light BaseUnit or server module in the station configuration.

Signal type

You can select from the following signal types:

Signal type	Meaning
Incremental encoder (A, B phase-shifted)	An incremental encoder with phase-shifted A and B signals is connected.
Incremental encoder (A, B, N)	An incremental encoder with phase-shifted signals A and B and a zero signal N is connected.
Pulse (A) and direction (B)	A pulse encoder (signal A) with direction signal (signal B) is connected.
Pulse (A)	A pulse encoder (signal A) without direction signal is connected.
Count up (A), count down (B)	Signals for counting up (signal A) and down (signal B) are connected.

Invert direction

You can invert the counting direction to adapt it to the process.

The inverting of the direction is configurable and active for the following signal types:

- Incremental encoder (A, B phase-shifted)
- Incremental encoder (A, B, N)

Signal evaluation

With the parameter assignment of the signal evaluation, you specify which edges of the signals are counted.

You can select from the following options:

Signal evaluation	Meaning
Single	The edges of signal A are evaluated during a low level of signal B.
Double	Each edge of signal A is evaluated.
Quadruple	Each edge of signals A and B is evaluated.

The parameter can be assigned with the following signal types:

- Incremental encoder (A, B phase-shifted)
- Incremental encoder (A, B, N)

Filter frequency

By configuring the filter frequency, you suppress interferences at the counting inputs A, B and N.

The selected filter frequency is based on a pulse/break ratio of between around 40:60 and around 60:40. This results in a specific minimum pulse/break time. Signal changes with a duration shorter than the minimum pulse/break time are suppressed.

You can select from the following filter frequencies:

Filter frequency	Minimum pulse/break time
100 Hz	4.0ms
200 Hz	2.0 ms
500 Hz	800 μ s
1 kHz	400 μ s
2 kHz	200 μ s
5 kHz	80 μ s
10 kHz	40 μ s
20 kHz	20 μ s
50 kHz	8.0 μ s
100 kHz	4.0 μ s
200 kHz	2.0 μ s

Reaction to signal N

You use this parameter to specify which reaction to signal N is triggered.

You can select from the following options:

Option	Meaning
No reaction to signal N	The counter is not affected by signal N.
Synchronization at signal N	The counter is set to the start value at signal N. If you select the function "Enable synchronization at signal N" for a digital input, the synchronization depends on the level at the digital input.

Note

You can only select the reaction to signal N if you have selected the "Incremental encoder (A, B, N)" signal type.

Note

If you select "Synchronization at signal N", you can choose the "Enable synchronization at signal N" function for a digital input.

Frequency of synchronization

This parameter is used to define the frequency of the following events:

- Synchronization at signal N
- Synchronization as function of a digital input

You can select from the following options:

Option	Meaning
Once	The counter is only set at the first signal N or the first configured edge of the digital input.
Periodic	The counter is set at each signal N or each configured edge of the digital input.

Count direction of the synchronization

You use this parameter to specify the count direction for which the following functions are enabled:

- Synchronization at signal N
- Synchronization as function of a digital input

You can select from the following options:

Option	Meaning
In both directions	Synchronization takes place regardless of the count direction.
Up	Synchronization only takes place when the counter is counting up.
Down	Synchronization only takes place when the counter is counting down.

Sensor type

With the parameter assignment of the sensor type, you specify how the counter inputs are switched.

You can select from the following options:

Option	Meaning
Sourcing output	The encoder or sensor switches the A, B and N inputs to 24 V DC.
Sinking output	The encoder or sensor switches the A, B and N inputs to M.
Push-pull (sinking and sourcing output)	The encoder or sensor switches the A, B and N inputs to alternately to M and 24 V DC.

"Push-pull" is usually selected when incremental encoders are used. If using 2-wire sensors, such as light barriers or proximity switches, you need to select the corresponding wiring "sourcing output" or "sinking output".

The data sheet of the encoder includes information on whether your incremental encoder is a push-pull encoder.

Note

If you use a push-pull encoder and the sensor type "Push-pull (sinking and sourcing output)" is configured, you can monitor the encoder signals for wire break.

Counting high limit

With the parameter assignment of the counting high limit, you limit the counting range. You can enter a value up to 33554431 ($2^{25}-1$). You must enter a value above the counting low limit.

Counting low limit

With the parameter assignment of the counting low limit, you limit the counting range. You can enter a value starting with 0. You must enter a value below the counting high limit.

4.4 Fast Mode

Start value

With the parameter assignment of the start value, you specify the value at which counting is begun and is to continue in the case of defined events. You must enter a value at or within the counting limits.

Reaction to violation of a counting limit

You can configure the following reaction to violation of a counting limit:

Reaction	Meaning
Stop counting	After violation of a counting limit, counting is stopped and the internal gate is closed. To restart counting, you must close and reopen the SW gate or HW gate, if necessary.
Continue counting	Counting is continued with the start value or at the opposite counting limit depending on the additional parameter assignment.

Reset when counting limit is violated

You can reset the counter when a counting limit is violated:

Reset the value	Meaning
To start value	The counter value is set to the start value.
To opposite counting limit	The counter value is set to the opposite counting limit in each case.

Reaction to gate start

You can configure the following reaction to gate start:

Reaction	Meaning
Set to start value	When the gate is opened, the counter value is set to the start value.
Continue with current value	When the gate is opened, counting is continued with the last counter value.

Note

The parameter is only effective when you have configured a HW gate.

Set function of DI

With the parameter assignment of a digital input, you specify which function the digital input triggers when switched.

You can select from the following options:

Function of a digital input	Meaning
Gate start/stop (level-triggered)	The level at the respective digital input opens and closes the HW gate.
Gate start (edge-triggered)	The configured edge at the respective digital input opens the HW gate.
Gate stop (edge-triggered)	The configured edge at the respective digital input closes the HW gate.
Synchronization	The configured edge at the respective digital input sets the counter to the start value.
Enable synchronization at signal N	The active level at the respective digital input enables synchronization of the counter at signal N.
Digital input without function	No technological function is assigned to the respective digital input. You can read the signal status of the digital input via the feedback interface.

Note

Each function, except "Digital input without function", can be used only once per counter and can no longer be selected for the other digital inputs in each case.

Input delay

You use this parameter to suppress signal noise at the digital inputs. Changes to the signal are only detected if they remain stable for longer than the configured input delay time.

Note

If you select the "None" or "0.05 ms" option, you must use shielded cables for connection of the digital inputs.

Note

You configure the input delay under "Behavior of DI0" for all digital inputs together. The input delay is also displayed under "Behavior of DI1".

Select level

You use this parameter to specify the level at which the digital input is active.

You can select from the following options:

Level	Meaning
Active with high level	The respective digital input is active when it is set.
Active with low level	The respective digital input is active when it is not set.

The parameter can be configured for the following functions of a digital input:

- Gate start/stop (level-triggered)
- Enable synchronization at signal N

Edge selection

You use this parameter to specify the edge of the digital input at which the configured function is triggered.

You can select from the following options depending on the function selected:

- At rising edge
- At falling edge

The parameter can be configured for the following functions of a digital input:

- Gate start (edge-triggered)
- Gate stop (edge-triggered)
- Synchronization

Set output

With the parameter assignment of a digital output, you specify the condition upon which the digital output switches.

You can select from the following options:

Function of a digital output	Meaning
Between comparison value and high limit	The respective digital output is active if: Comparison value \leq counter value \leq counting high limit
Between comparison value and low limit	The respective digital output is active if: Low limit \leq counter value \leq comparison value
Between comparison value 0 and 1	The digital output DQ1 is active if: Comparison value 0 \leq counter value \leq comparison value 1
At comparison value for a pulse duration	The respective digital output is active once for the configured time and count direction when the counter value corresponds to the comparison value.
Digital output without function	The respective digital output is set to 0 irrespective of the reaction to CPU STOP.

Note

You can only set the "Between comparison value 0 and 1" function for digital output DQ1 and only if you have selected the "Digital output without function" function for digital output DQ0.

Comparison value 0

With the parameter assignment of the comparison value, you specify the counter value at which the digital output DQ0 switches as a result of the selected comparison event.

You must enter an integer (DINT) that is greater than or equal to the counting low limit. If you use the DQ function "Between comparison value 0 and 1", comparison value 0 must be less than comparison value 1.

Comparison value 1

With the parameter assignment of the comparison value, you specify the counter value at which the digital output DQ1 switches as a result of the selected comparison event.

You must enter an integer (DINT) that is less than or equal to the counting high limit. If you use the DQ function "Between comparison value 0 and 1", comparison value 0 must be less than comparison value 1.

Count direction

You use this parameter to specify the count direction for which the selected functions is valid:

You can select from the following options:

Count direction	Meaning
In both directions	The comparison and switching of the respective digital output takes places regardless of the count direction.
Up	The comparison the switching of the respective digital output only takes place when the counter counts up.
Down	The comparison and switching of the respective digital output only takes place when the counter counts down.

The parameter can be configured for the following functions:

- Between comparison value 0 and 1
- At comparison value for a pulse duration

Pulse duration

With the parameter assignment of the pulse duration for the "At comparison value for a pulse duration" function, you specify how many milliseconds the respective digital output is active.

If you enter "0" and the counter value corresponds to the respective comparison value, the digital output is active until the next count pulse.

Hysteresis (in increments)

With the parameter assignment of the hysteresis, you specify a range around the comparison values. Within the hysteresis range, the digital outputs cannot switch again before the counter value has left this range.

An encoder can stop at a certain position, and slight movements can cause the counter value to fluctuate around this position. If a comparison value or counting limit is within the fluctuation range and a hysteresis is not used, the associated digital output will switch on and off with corresponding frequency. The hysteresis prevents these unwanted switching actions.

Regardless of the hysteresis value, the hysteresis range ends at the low or counting high limit. If you enter "0", the hysteresis is turned off.

4.4.5 Address space

Address space of the technology module

Table 4- 12 Size of input and output addresses of the TM Count 1x24V with Fast Mode

	Inputs	Outputs
Range	4 bytes	0 bytes

4.4.6 Assignment of the feedback interface

The user program receives current values and status information from the technology module by means of the feedback interface.

Feedback interface

The following table shows the assignment of the feedback interface:

Byte offset from start address ↓	Bit 7	Bit 6	Bit 5	Bit 4	Bit 3	Bit 2	Bit 1	Bit 0
0	LS	STS_READY	Reserved	EXT_F	STS_DI0	STS_DIR	STS_DI1	COUNT_VALUE
1	COUNT_VALUE: DINT: Current counter value or position value							
2								
3								

Explanation of feedback bits

Feedback bit	Explanations
COUNT_VALUE	This value returns the current counter value in the first 25 bits of a DINT value.
EXT_F	<p>This bit indicates that one of the following errors has occurred at the encoder signals for the technology module:</p> <ul style="list-style-type: none"> • Load voltage missing • Wire break of digital input A, B or N (with push-pull encoder) • Invalid transition of A/B signals (with incremental encoder) <p>If you have enabled the diagnostic interrupts, the respective diagnostic interrupt is triggered in the event of encoder signal errors. For information on the meaning of the diagnostic interrupts, refer to section Diagnostic alarms (Page 78).</p> <p>The bit is reset automatically as soon as an error no longer exists.</p>
LS	<p>As a life sign, this bit indicates by a status change (toggling) that isochronous mode is functioning and the module has updated the feedback interface in the respective bus cycle.</p> <p>In non-isochronous mode, this bit is set to 0.</p>
STS_DI0	This bit indicates the status of digital input DI0.
STS_DI1	This bit indicates the status of digital input DI1.
STS_DI2	This bit indicates the status of digital input DI2.
STS_DIR	<p>This bit indicates the count direction of the last count pulse.</p> <p>0 means: Down 1 means: Up</p>
STS_READY	This bit indicates that the technology module supplies valid user data. The technology module has been started up and configured.

4.4.7 Isochronous mode

The technology module supports the "Isochronous mode" system function. Counter values can be acquired in a fixed system cycle with this system function.

In isochronous mode, the cycle of the user program, the transmission of the input signals and processing in the technology module are synchronized. The output signals switch immediately if the relevant comparison condition is met. A status change of a digital input immediately triggers the specified reaction of the technology module and the change of the status bit of the digital input in the feedback interface.

This operating mode is especially well-suited for short send clocks of the CPU starting from 125 µs, because only input data is used.

Use an OB of type "Synchronous Cycle" (e.g. OB61) in this operating mode.

Data processing

At the time the input data is read in (T_i), the counter value and the status bits are acquired and made available in the feedback interface for retrieval in the current bus cycle.

Isochronous mode parameters

In isochronous mode, the "Filter frequency" parameter can affect the isochronous mode parameters of the sync domain.

Because the isochronous mode parameters are not checked in RUN, overflows can occur if you change the parameters in RUN. To prevent overflows, select the option with the largest time required in the offline parameter assignment.

Additional information

You can find a detailed description of isochronous mode in the following:

- Function manual Isochronous Mode (STEP 7 (TIA Portal) V15.1 or higher) available for download on the Internet (<https://support.industry.siemens.com/cs/ww/en/view/109755401>)
- Function manual PROFINET with STEP 7 available for download on the Internet (<https://support.industry.siemens.com/cs/ww/en/view/49948856>)

Interrupts/diagnostic messages

5.1 Status and error display

LEDs

The following figure shows you the LED displays (status and error displays) of TM Count 1x24V.

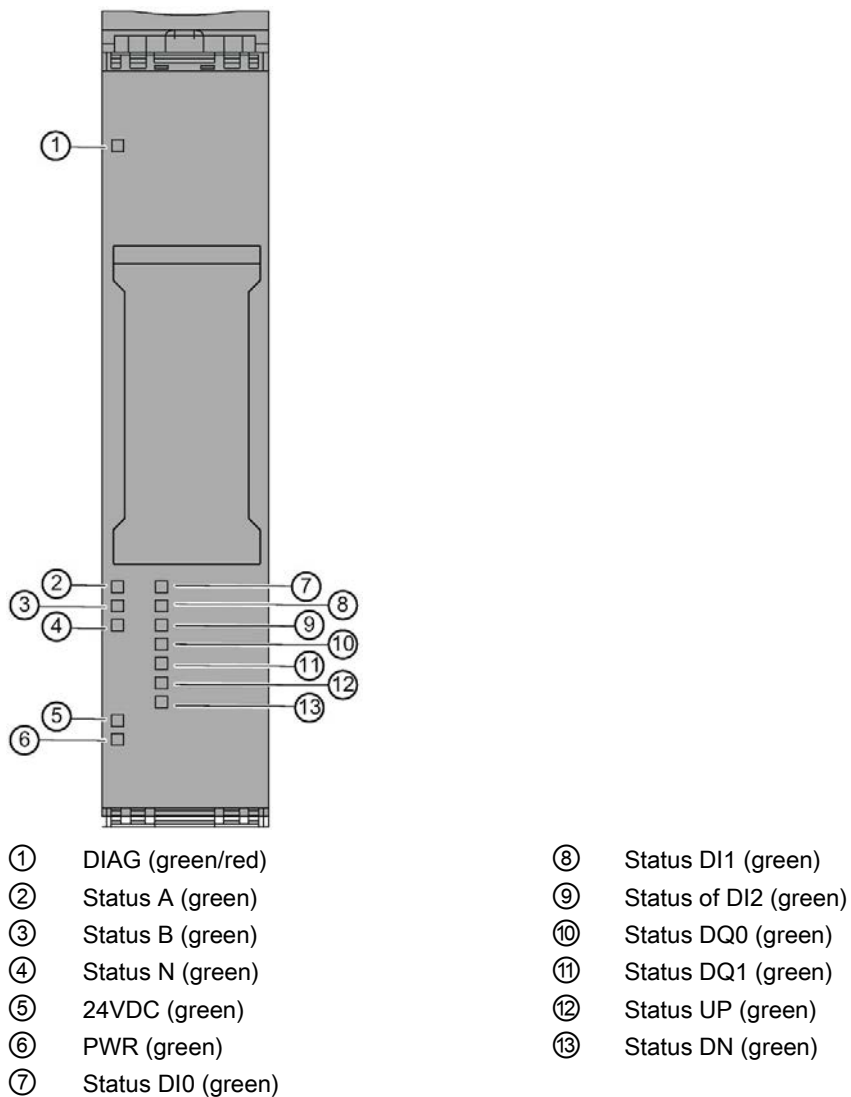

Figure 5-1 LED displays of the TM Count 1x24V

Meaning of the LED displays

The following tables explain the meaning of the status and error displays. Remedial measures for diagnostic alarms can be found in section Diagnostic messages (Page 77).

Table 5- 1 Status and error displays DIAG

LED DIAG	Meaning	Remedy
□ Off	Backplane bus supply of the ET 200SP not OK	Check or switch on the supply voltage on the CPU or on the interface module.
⚡ Flashes	Technology module parameters not set	---
■ On	Technology module parameters set and no module diagnostics	---
⚡ Flashes	Technology module parameters set and module diagnostics (at least one error is present)	Evaluate the diagnostic alarms and eliminate the error.

Table 5- 2 PWR/24VDC status displays

LEDs		Meaning	Remedy
PWR	24VDC		
□ Off	□ Off	Supply voltage missing	<ul style="list-style-type: none"> • Check the supply voltage. • Check the BaseUnit type and the wiring of the BaseUnit.
■ On	■ On	Supply voltage is present and OK	---
■ On	□ Off	Short-circuit or overload at the encoder supply or supply voltage too low	<ul style="list-style-type: none"> • Check the encoder wiring. • Check the loads connected to the encoder supply. • Check the supply voltage.

Channel LEDs

The A, B, N and DIm LEDs indicate the current level of the associated signals. The LEDs of the DQm digital outputs indicate the desired state.

The UP and DN LEDs indicate the logical counting direction.

The flashing frequency of the channel LEDs is limited to approximately 12 Hz. If higher frequencies are present, the channel LEDs will flash at 12 Hz instead of indicating the current status.

Table 5- 3 Status displays A/B/N/DIm/DQm

LEDs A/B/N/DIm/DQm	Meaning
□ Off	Counter input/digital input/digital output at 0 level
■ On	Counter input/digital input/digital output at 1 level

Table 5- 4 Status displays UP/DN

LEDs		Meaning
UP	DN	
□ Off	□ Off	No count pulse has been detected for the last 0.5 s.
■ On	□ Off	The last count pulse has incremented the counter and took place no more than 0.5 s ago.
□ Off	■ On	The last count pulse has decremented the counter and took place no more than 0.5 s ago.

5.2 Diagnostic messages

Enabling of diagnostic interrupts

You enable the diagnostic interrupts in the device configuration with the basic parameters.

The technology module can trigger the following diagnostic interrupts:

Table 5- 5 Possible diagnostic interrupts

Diagnostic interrupt	Monitoring
<ul style="list-style-type: none"> • Parameter error • Hardware interrupt lost¹ • Channel/component temporarily unavailable • Internal error • Watchdog tripped. Module is defective. 	<p>Monitoring is always active. A diagnostic interrupt is triggered each time an error is detected.</p>
<ul style="list-style-type: none"> • Wire break at digital input A, B or N 	<p>Monitoring is active if a push-pull switching encoder has been configured. When an error is detected, a diagnostic interrupt is only triggered if "Enable diagnostic interrupt on wire break" is activated in the device configuration.</p>
<ul style="list-style-type: none"> • Error • Load voltage missing • Short-circuit / overload at external encoder supply • Error at digital outputs • Supply voltage error² • Invalid transition of A/B signals • Overtemperature 	<p>Monitoring is always active. When an error is detected, a diagnostic interrupt is only triggered if "Enable additional diagnostic interrupts" is activated in the device configuration.</p>

¹ Not available in "Position input for "Motion Control"" technology object" and "Fast Mode" operating modes

² No longer available as of module version V1.2 This case is then taken into account by diagnostic interrupt "Load voltage missing".

Reactions to a diagnostic interrupt

The following happens when an event occurs that triggers a diagnostic interrupt:

- The DIAG LED flashes red.

When you have eliminated all errors, the DIAG LED stops flashing red and turns green.

- The S7-1500 CPU interrupts the processing of the user program. The diagnostic interrupt OB (e.g. OB 82) is called. The event that triggered the interrupt is entered in the start information of the diagnostic interrupt OB.
- The S7-1500 CPU remains in RUN, even if no diagnostic interrupt OB is present in the CPU. The technology module continues working unchanged if this is possible despite the error.

You can obtain detailed information on the error event in the error organization block with instruction "RALRM" (Read additional alarm information), in the information system of STEP 7 and in function manual Diagnostics (<https://support.industry.siemens.com/cs/ww/en/view/59192926>), section "System diagnostics in user program".

If the module is being operated as a distributed module in an ET 200SP system with PROFIBUS DP, you have the option of reading out diagnostic data with the RDREC or RD_REC instruction using data record 0 and 1. You can find the structure of the data records in the manual for the IM 155-6 DP HF interface module available for download on the Internet (<https://support.industry.siemens.com/cs/ww/de/view/73098660>).

Diagnostic alarms

The display of diagnostics is in plain text in STEP 7 (TIA Portal) in the online and diagnostics view. You can evaluate the error codes with the user program.

The following diagnostics can be signaled:

Table 5- 6 Diagnostic alarms, their meaning and remedies

Diagnostic alarm	Error code	Meaning	Remedy
Error	9H	<ul style="list-style-type: none"> • Internal module error occurred • Possible cause: Technology module defective 	Replace technology module
Parameter error	10H	<ul style="list-style-type: none"> • The received parameter data record is invalid • The configured BaseUnit is not the used BaseUnit 	<ul style="list-style-type: none"> • Check parameter data record • Check BaseUnit
Load voltage missing	11H	<ul style="list-style-type: none"> • Missing or insufficient supply voltage L+ • Wiring of supply voltage L+ faulty • Possible cause: BaseUnit type incorrect 	<ul style="list-style-type: none"> • Check BaseUnit type • Check supply voltage L+ on the BaseUnit • Check wiring of supply voltage L+ • Check total consumption of the load group

5.2 Diagnostic messages

Diagnostic alarm	Error code	Meaning	Remedy
Hardware interrupt lost	16H	<ul style="list-style-type: none"> Module cannot issue interrupt because a preceding interrupt has not yet been processed Possible cause: Too many hardware interrupts in too short a time 	<ul style="list-style-type: none"> Change interrupt processing in the CPU and re-assign technology module parameters correspondingly Check frequency of interrupts from the process
Channel/component temporarily unavailable	1FH	Firmware update in progress or update was aborted. The module reads no process values in this state.	<ul style="list-style-type: none"> Wait for firmware update If firmware update aborts: <ul style="list-style-type: none"> Check minimum firmware version required Check supply voltage Repeat firmware update
Internal error	100H	Technology module defective	Replace technology module
Watchdog tripped. Module is defective.	103H	Firmware error	Run firmware update
		Technology module defective	Replace technology module
Short-circuit / overload at external encoder supply	10EH	<ul style="list-style-type: none"> Error at encoder supply Possible causes: <ul style="list-style-type: none"> Short circuit Overload 	<ul style="list-style-type: none"> Check encoder wiring Check consumers connected to encoder supply
Error at digital outputs	10FH	<ul style="list-style-type: none"> Error at digital outputs (LED display DQm lit red) Possible causes: <ul style="list-style-type: none"> Short circuit Overload 	<ul style="list-style-type: none"> Check wiring at the digital outputs Check consumers connected to the digital outputs
Supply voltage error ¹	110H	<ul style="list-style-type: none"> Error at supply voltage L+ Possible causes: <ul style="list-style-type: none"> Low voltage Wiring of supply voltage L+ faulty 	<ul style="list-style-type: none"> Check supply voltage L+ on the BaseUnit Check wiring of supply voltage L+ Check total consumption of the load group
Invalid transition of A/B signals	500H	<ul style="list-style-type: none"> Time profile of signals A and B of the incremental encoder does not meet certain requirements (relative phase shift of the two signals is too small) Possible causes: <ul style="list-style-type: none"> Signal frequency too high Encoder faulty Process wiring faulty 	<ul style="list-style-type: none"> Check process wiring Check encoder/sensor Check parameter assignment
Wire break at digital input A, B or N	505H	Channel not connected	Connect the channel
		Resistance of encoder circuit too high	<ul style="list-style-type: none"> Use a different encoder type or modify the wiring, for example, use shorter cables with larger cross-sections Check encoders

Diagnostic alarm	Error code	Meaning	Remedy
		Interruption of the line between technology module and encoder	Check process wiring
		Sensor used is sourcing output or sinking output only	Correct parameter assignment
Overtemperature	506 _H	Possible causes: <ul style="list-style-type: none"> • Short-circuit or overload at the digital outputs or output of the encoder supply • Ambient temperature outside specifications • Contamination in the module prevents cooling 	<ul style="list-style-type: none"> • Check process wiring • Improve cooling • Check connected loads

¹ No longer available as of module version V1.2. This case is then taken into account by diagnostic interrupt "Load voltage missing".

5.3 Hardware interrupts

Introduction

For the technology module, you can configure which events are to trigger a hardware interrupt during operation.

What is a hardware interrupt?

The technology module will trigger a hardware interrupt as configured in response to specific events/states. When a hardware interrupt occurs, the CPU interrupts execution of the user program and processes the assigned hardware interrupt OB. The event that triggered the interrupt is entered in the start information of the assigned hardware interrupt OB by the CPU.

Lost hardware interrupt

If an event occurs that is to trigger a hardware interrupt and the preceding event has not yet been processed, another hardware interrupt cannot be triggered. The hardware interrupt is lost and the diagnostic interrupt "Lost hardware interrupt" is triggered.

Enabling of hardware interrupts

A hardware interrupt is triggered when the condition for the change of the respective status or event bit in the feedback interface is met.

You enable the hardware interrupts in the device configuration with the basic parameters. You can configure hardware interrupts to be triggered for the following event types:

- Opening of internal gate (gate start)
- Closing of internal gate (gate stop)
- Overflow (high counting limit violated)
- Underflow (low counting limit violated)
- Comparison event for DQ0 has occurred
- Comparison event for DQ1 has occurred
- Zero crossing³
- New Capture value available¹
- Synchronization of the counter by an external signal
- Direction reversal²

¹ Only configurable in Counting mode

² Feedback bit STS_DIR is preassigned with "0". If the first counter value change occurs in the *downwards direction* directly after switching on the technology module, no hardware interrupt is triggered.

³ When the "Zero crossing" hardware interrupt is enabled, for system-related reasons it can also be triggered if "0" is outside the configured value range.

You can activate any combination of events to trigger hardware interrupts.

You can obtain detailed information on the event in the hardware interrupt organization block with instruction "RALRM" (Read additional alarm information) and in the information system of STEP 7.

Which event has triggered the hardware interrupt is entered in the start information of the organization block. The following figure shows the assignment to the bits of the local data double word 8.

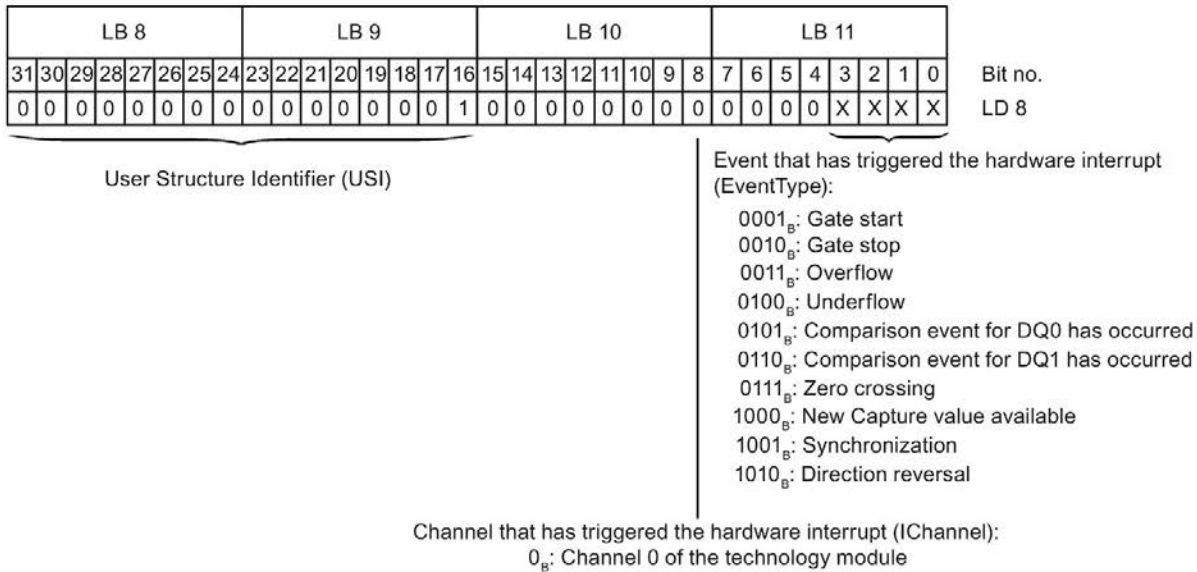

Figure 5-2 Start information of the organization block

Technical specifications

Article number	6ES7138-6AA00-0BA0
General information	
Product type designation	TM Count 1x24V
Firmware version	V1.3
<ul style="list-style-type: none"> FW update possible 	Yes
usable BaseUnits	BU type A0
Product function	
<ul style="list-style-type: none"> I&M data 	Yes; I&M0 to I&M3
Engineering with	
<ul style="list-style-type: none"> STEP 7 TIA Portal configurable/integrated as of version 	V13 (FW V1.0), V14 (V1.2), V15 (FW V1.3) / V13 (FW V1.0), V14 SP1 (V1.2)
<ul style="list-style-type: none"> STEP 7 configurable/integrated as of version 	As of V5.5 SP3, only up to FW V1.2
<ul style="list-style-type: none"> PROFIBUS as of GSD version/GSD revision 	GSD Revision 5
<ul style="list-style-type: none"> PROFINET as of GSD version/GSD revision 	GSDML V2.3
Supply voltage	
Load voltage L+	
<ul style="list-style-type: none"> Rated value (DC) 	24 V
<ul style="list-style-type: none"> permissible range, lower limit (DC) 	19.2 V
<ul style="list-style-type: none"> permissible range, upper limit (DC) 	28.8 V
<ul style="list-style-type: none"> Reverse polarity protection 	Yes
Input current	
Current consumption, max.	60 mA; without load
Encoder supply	
Number of outputs	1
24 V encoder supply	
<ul style="list-style-type: none"> 24 V 	Yes; L+ (-0.8 V)
<ul style="list-style-type: none"> Short-circuit protection 	Yes; electronic/thermal
<ul style="list-style-type: none"> Output current, max. 	300 mA
Power loss	
Power loss, typ.	1 W

Article number	6ES7138-6AA00-0BA0
Address area	
Occupied address area	
<ul style="list-style-type: none"> Inputs 	16 byte; 4 bytes in Fast mode
<ul style="list-style-type: none"> Outputs 	12 byte; 4 bytes for Motion Control, 0 bytes for Fast mode
Digital inputs	
Number of digital inputs	3
Digital inputs, parameterizable	Yes
Input characteristic curve in accordance with IEC 61131, type 3	Yes
Digital input functions, parameterizable	
<ul style="list-style-type: none"> Gate start/stop 	Yes
<ul style="list-style-type: none"> Capture 	Yes
<ul style="list-style-type: none"> Synchronization 	Yes
<ul style="list-style-type: none"> Freely usable digital input 	Yes
Input voltage	
<ul style="list-style-type: none"> Rated value (DC) 	24 V
<ul style="list-style-type: none"> for signal "0" 	-5 ... +5 V
<ul style="list-style-type: none"> for signal "1" 	+11 to +30V
<ul style="list-style-type: none"> permissible voltage at input, min. 	-30 V; -5 V continuous, -30 V brief reverse polarity protection
<ul style="list-style-type: none"> permissible voltage at input, max. 	30 V
Input current	
<ul style="list-style-type: none"> for signal "1", typ. 	2.5 mA
Input delay (for rated value of input voltage) for standard inputs	
<ul style="list-style-type: none"> parameterizable 	Yes; none / 0.05 / 0.1 / 0.4 / 0.8 / 1.6 / 3.2 / 12.8 / 20 ms
<ul style="list-style-type: none"> at "0" to "1", min. 	6 µs; for parameterization "none"
<ul style="list-style-type: none"> at "1" to "0", min. 	6 µs; for parameterization "none"
for counter/technological functions	
<ul style="list-style-type: none"> parameterizable 	Yes
Cable length	
<ul style="list-style-type: none"> shielded, max. 	1 000 m
<ul style="list-style-type: none"> unshielded, max. 	600 m

Article number	6ES7138-6AA00-0BA0
Digital outputs	
Type of digital output	Transistor
Number of digital outputs	2
Short-circuit protection	Yes; electronic/thermal
• Response threshold, typ.	1 A
Limitation of inductive shutdown voltage to	L+ (-33 V)
Controlling a digital input	Yes
Digital output functions, parameterizable	
• Switching tripped by comparison values	Yes
• Freely usable digital output	Yes
Switching capacity of the outputs	
• with resistive load, max.	0.5 A; Per digital output
• on lamp load, max.	5 W
Load resistance range	
• lower limit	48 Ω
• upper limit	12 k Ω
Output voltage	
• for signal "1", min.	23.2 V; L+ (-0.8 V)
Output current	
• for signal "1" rated value	0.5 A; Per digital output
• for signal "1" permissible range, max.	0.6 A; Per digital output
• for signal "1" minimum load current	2 mA
• for signal "0" residual current, max.	0.5 mA
Output delay with resistive load	
• "0" to "1", max.	50 μ s
• "1" to "0", max.	50 μ s
Switching frequency	
• with resistive load, max.	10 kHz
• with inductive load, max.	0.5 Hz; Acc. to IEC 60947-5-1, DC-13; observe derating curve
• on lamp load, max.	10 Hz
Total current of the outputs	
• Current per module, max.	1 A
Cable length	
• shielded, max.	1 000 m
• unshielded, max.	600 m

Article number	6ES7138-6AA00-0BA0
Encoder	
Connectable encoders	
<ul style="list-style-type: none"> • 2-wire sensor 	Yes
<ul style="list-style-type: none"> – permissible quiescent current (2-wire sensor), max. 	1.5 mA
Encoder signals, incremental encoder (asymmetrical)	
<ul style="list-style-type: none"> • Input voltage 	24 V
<ul style="list-style-type: none"> • Input frequency, max. 	200 kHz
<ul style="list-style-type: none"> • Counting frequency, max. 	800 kHz; with quadruple evaluation
<ul style="list-style-type: none"> • Cable length, shielded, max. 	600 m; depending on input frequency, encoder and cable quality; max. 50 m at 200 kHz
<ul style="list-style-type: none"> • Signal filter, parameterizable 	Yes
<ul style="list-style-type: none"> • Incremental encoder with A/B tracks, 90° phase offset 	Yes
<ul style="list-style-type: none"> • Incremental encoder with A/B tracks, 90° phase offset and zero track 	Yes
<ul style="list-style-type: none"> • Pulse encoder 	Yes
<ul style="list-style-type: none"> • Pulse encoder with direction 	Yes
<ul style="list-style-type: none"> • Pulse encoder with one impulse signal per count direction 	Yes
Encoder signal 24 V	
<ul style="list-style-type: none"> – permissible voltage at input, min. 	-30 V
<ul style="list-style-type: none"> – permissible voltage at input, max. 	30 V
Interface types	
<ul style="list-style-type: none"> • Source/sink input 	Yes
<ul style="list-style-type: none"> • Input characteristic curve in accordance with IEC 61131, type 3 	Yes
Isochronous mode	
Isochronous operation (application synchronized up to terminal)	Yes

Article number	6ES7138-6AA00-0BA0
Interrupts/diagnostics/status information	
Substitute values connectable	Yes; Parameterizable
Alarms	
• Diagnostic alarm	Yes
• Hardware interrupt	Yes
Diagnostic messages	
• Monitoring the supply voltage	Yes
• Wire-break	Yes
• Short-circuit	Yes
• A/B transition error at incremental encoder	Yes
• Group error	Yes
Diagnostics indication LED	
• Monitoring of the supply voltage (PWR-LED)	Yes; green PWR LED
• Channel status display	Yes; Green LED
• for module diagnostics	Yes; green/red DIAG LED
• Status indicator backward counting (green)	Yes
• Status indicator forward counting (green)	Yes
Integrated Functions	
Number of counters	1
Counting frequency (counter) max.	800 kHz; with quadruple evaluation
Counting functions	
• Can be used with TO High_Speed_Counter	Yes
• Continuous counting	Yes
• Counter response parameterizable	Yes
• Hardware gate via digital input	Yes
• Software gate	Yes
• Event-controlled stop	Yes
• Synchronization via digital input	Yes
• Counting range, parameterizable	Yes
Comparator	
– Number of comparators	2
– Direction dependency	Yes
– Can be changed from user program	Yes

Article number	6ES7138-6AA00-0BA0
Position detection	
<ul style="list-style-type: none"> Incremental acquisition 	Yes
<ul style="list-style-type: none"> Suitable for S7-1500 Motion Control 	Yes
Measuring functions	
<ul style="list-style-type: none"> Measuring time, parameterizable 	Yes
<ul style="list-style-type: none"> Dynamic measurement period adjustment 	Yes
<ul style="list-style-type: none"> Number of thresholds, parameterizable 	2
Measuring range	
<ul style="list-style-type: none"> Frequency measurement, min. 	0.04 Hz
<ul style="list-style-type: none"> Frequency measurement, max. 	800 kHz
<ul style="list-style-type: none"> Cycle duration measurement, min. 	1.25 µs
<ul style="list-style-type: none"> Cycle duration measurement, max. 	25 s
Accuracy	
<ul style="list-style-type: none"> Frequency measurement 	100 ppm; depending on measuring interval and signal evaluation
<ul style="list-style-type: none"> Cycle duration measurement 	100 ppm; depending on measuring interval and signal evaluation
<ul style="list-style-type: none"> Velocity measurement 	100 ppm; depending on measuring interval and signal evaluation
Potential separation	
Potential separation channels	
<ul style="list-style-type: none"> between the channels and backplane bus 	Yes
Isolation	
Isolation tested with	707 V DC (type test)
Decentralized operation	
to SIMATIC S7-300	Yes
to SIMATIC S7-400	Yes
to SIMATIC S7-1200	Yes
to SIMATIC S7-1500	Yes
to standard PROFIBUS master	Yes
to standard PROFINET controller	Yes
Dimensions	
Width	15 mm
Height	73 mm
Depth	58 mm
Weights	
Weight, approx.	45 g

Derating information for total current of outputs

If the digital outputs of the TM Count 1x24V are operated with resistive or inductive loads, you should derate the total current of the loads at the digital outputs of the technology module. The total current is the sum of the load currents at all digital outputs of the module (without encoder supply).

The following derating curve shows the load capacity of the digital outputs depending on the ambient temperature and mounting position under the following conditions:

- Load resistance: 48 Ω (IEC 947-5-1)

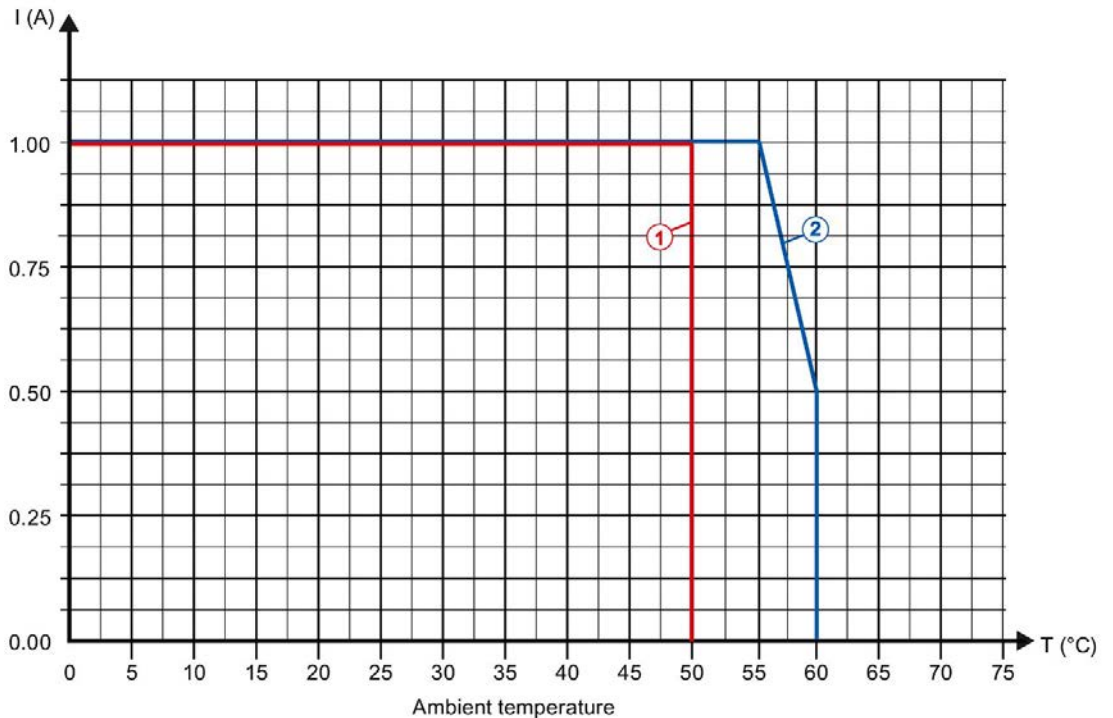

- ① Vertical installation of the system
- ② Horizontal installation of the system

Figure 6-1 Total current depending on ambient temperature and mounting position for resistive loads

The following derating curve shows the load capacity of the digital outputs depending on the ambient temperature and mounting position under the following conditions:

- Maximum switching frequency at digital outputs of 0.5 Hz
- Load resistance: 48 Ω (IEC 947-5-1)
- Load inductance: 1150 mH (IEC 947-5-1)

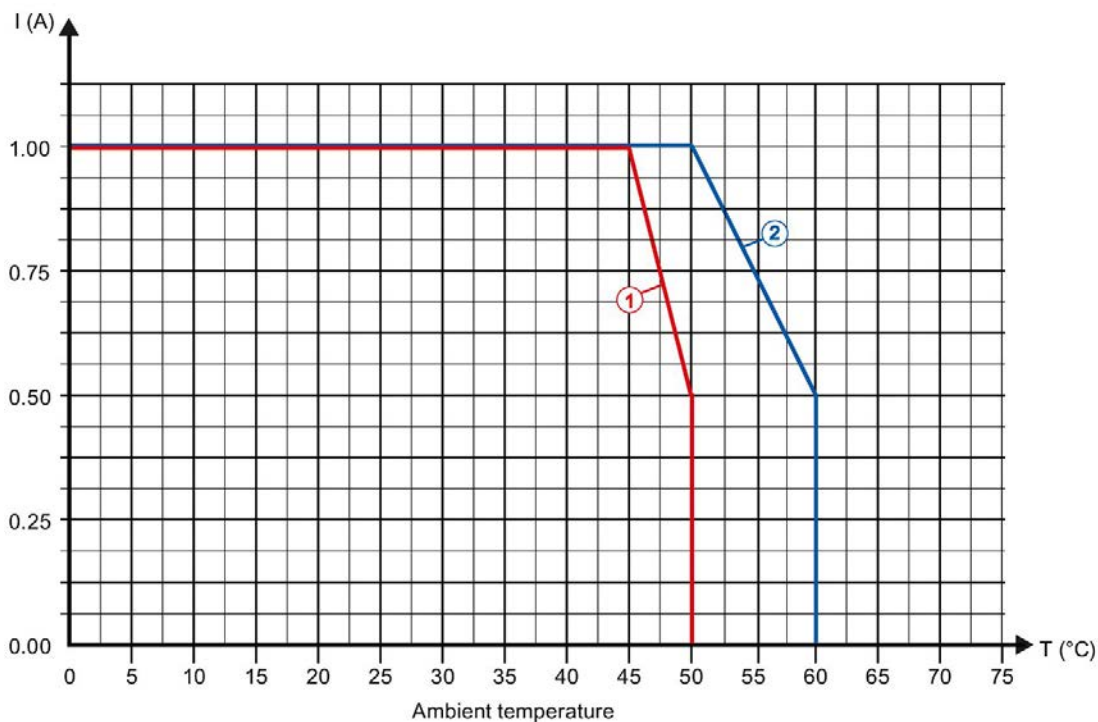

- ① Vertical installation of the system
- ② Horizontal installation of the system

Figure 6-2 Total current depending on ambient temperature and mounting position for inductive loads

Note

If the switching frequency is greater than 0.5 Hz or there is greater inductance at the digital outputs, the total current must be reduced further.

Dimension drawing

See ET 200SP BaseUnits
<http://support.automation.siemens.com/WW/view/en/58532597/133300> manual

Parameter data record

A.1 Parameter assignment and structure of parameter data record

You have the option of reassigning module parameters with the user program while the CPU is in RUN. The parameters are transferred to the module using data record 128, e.g. with the WRREC instruction.

If an error occurs while transferring or validating parameters with the WRREC instruction, the module continues operating with the existing parameter assignment. A corresponding error code is then written to the STATUS output parameter. If no errors occur, the STATUS output parameter contains the length of the actually transferred data.

You can find a description of the WRREC instruction and the error codes in section Parameter validation error (Page 101) or in the online help of STEP 7 (TIA Portal).

Structure of data record 128 for operation with technology object and manual operation

The following table shows you the structure of data record 128 for TM Count 1x24V for operation with technology object and manual operation without technology object. The values in byte 0 to byte 3 are fixed and must not be changed. The value in byte 4 can only be changed by means of new parameter assignment and not in RUN mode of the CPU.

Note

After each writing of data record 128, the module is set to its startup state and the counter value is set to the start value. If "Continue operation" is set for Reaction to CPU STOP, the module is then only set to its startup state when data record 128 has been changed.

Parameter data record

A.1 Parameter assignment and structure of parameter data record

Table A- 1 Data record 128: Operating modes "Operating with "Counting and measurement" technology object", "Manual operation (without technology object)"

Bit →	Bit 7	Bit 6	Bit 5	Bit 4	Bit 3	Bit 2	Bit 1	Bit 0
Byte ↓								
0...3	Header							
0	Major Version = 0				Minor Version = 2			
1	Length of the parameter data = 48							
2	Reserved ²							
3	Reserved ²							
4...51	Counting channel							
4	Operating mode							
4	Reserved ²				Operating mode:			
					0000 _B : Not permitted			
					0001 _B : Counting			
					0010 _B : Measuring			
					0011 to 1111 _B : Not permitted			
5	Basic parameters							
5	Reserved ²				Enable additional diagnostic interrupts ¹		Reaction to CPU STOP:	
							00 _B : Output substitute value	
							01 _B : Keep last value	
							10 _B : Continue operation	
							11 _B : Not permitted	

A.1 Parameter assignment and structure of parameter data record

Bit →	Bit 7		Bit 6		Bit 5		Bit 4		Bit 3		Bit 2		Bit 1		Bit 0	
Byte ↓	Bit 7		Bit 6		Bit 5		Bit 4		Bit 3		Bit 2		Bit 1		Bit 0	
6...7	Counter inputs															
6	Sensor type:				Signal evaluation:				Signal type:							
	00 _B : Sourcing output				00 _B : Single				0000 _B : Pulse (A)							
	01 _B : Sinking output				01 _B : Double				0001 _B : Pulse (A) and direction (B)							
	10 _B : Push-pull (sinking and sourcing output)				10 _B : Quadruple				0010 _B : Count up (A), count down (B)							
	11 _B : Not permitted				11 _B : Not permitted				0011 _B : Incremental encoder (A, B phase-shifted)							
									0100 _B : Incremental encoder (A, B, N)							
								0101 to 1111 _B : Not permitted								
7	Reaction to signal N:				Invert direction ¹				Enable diagnostic interrupt on wire break ¹				Filter frequency ³ :			
	00 _B : No reaction to signal N												0000 _B : 100 Hz			
	01 _B : Synchronization at signal N												0001 _B : 200 Hz			
	10 _B : Capture at signal N												0010 _B : 500 Hz			
	11 _B : Not permitted												0011 _B : 1 kHz			
													0100 _B : 2 kHz			
					0101 _B : 5 kHz											
					0110 _B : 10 kHz											
					0111 _B : 20 kHz											
					1000 _B : 50 kHz											
					1001 _B : 100 kHz											
				1010 _B : 200 kHz												
				1011 to 1111 _B : Not permitted												
8...9	Hardware interrupts¹															
8	Reserved ²				Change of direction		Underflow (low counting limit violated)		Overflow (high counting limit violated)		Gate stop		Gate start			
9	Synchronization of the counter by an external signal		New Capture value available		Reserved ²		Zero crossing		Reserved ²		Comparison event for DQ1 has occurred		Reserved ²		Comparison event for DQ0 has occurred	

A.1 Parameter assignment and structure of parameter data record

Bit →									
Byte ↓	Bit 7	Bit 6	Bit 5	Bit 4	Bit 3	Bit 2	Bit 1	Bit 0	
10...15	Behavior of DQ0/1								
10	Set output (DQ1):				Set output (DQ0):				
	0000 _B : Use by user program				0000 _B : Use by user program				
	0001 _B : Between comparison value and high limit; Measuring: Measured value >= comparison value				0001 _B : Between comparison value and high limit; Measuring: Measured value >= comparison value				
	0010 _B : Between comparison value and low limit; Measuring: Measured value <= comparison value				0010 _B : Between comparison value and low limit; Measuring: Measured value <= comparison value				
	0011 _B : At comparison value for a pulse duration				0011 _B : At comparison value for a pulse duration				
	0100 _B : Between comparison value 0 and 1				0100 _B : Not permitted				
	0101 _B : After set command from CPU until comparison value				0101 _B : After set command from CPU until comparison value				
	0110 _B : Not between comparison value 0 and 1				0110 to 1111 _B : Not permitted				
	0111 to 1111 _B : Not permitted								
11	Count direction (DQ1):		Count direction (DQ0):		Reserved ²		Substitute value for DQ1	Substitute value for DQ0	
	00 _B : Not permitted		00 _B : Not permitted						
	01 _B : Up		01 _B : Up						
	10 _B : Down		10 _B : Down						
	11 _B : In both directions		11 _B : In both directions						
12	Pulse duration (DQ0):								
13	WORD: Value range in ms/10: 0 to 65535 _D								
14	Pulse duration (DQ1):								
15	WORD: Value range in ms/10: 0 to 65535 _D								
16	Behavior of DI0								
16	Behavior of counter value after Capture (DI0):	Edge selection (DI0):		Select level (DI0):	Reserved ²	Set function of DI (DI0):			
		00 _B : Not permitted ⁵				0 _B : Active with high level	000 _B : Gate start/stop (level-triggered)		
		01 _B : At rising edge					001 _B : Gate start (edge-triggered)		
	10 _B : At falling edge		11 _B : At rising and falling edge	1 _B : Active with low level		010 _B : Gate stop (edge-triggered)			
	0 _B : Continue counting					011 _B : Synchronization			
	1 _B : Set to start value and continue counting					100 _B : Enable synchronization at signal N			
						101 _B : Capture			
						110 _B : Digital input without function			
					111 _B : Not permitted				

A.1 Parameter assignment and structure of parameter data record

Bit →									
Byte ↓	Bit 7	Bit 6	Bit 5	Bit 4	Bit 3	Bit 2	Bit 1	Bit 0	
17	Behavior of DI1: See Byte 16								
18	Behavior of DI2: See Byte 16								
19	Frequency of synchronization: 0 _B : Once 1 _B : Periodic	Reserved ²	Frequency of Capture function: 0 _B : Once 1 _B : Periodic	Input delay:					
				0000 _B : None					
				0001 _B : 0.05 ms					
	0010 _B : 0.1 ms								
	0011 _B : 0.4 ms								
	0100 _B : 0.8 ms								
	0101 _B : 1.6 ms								
	0110 _B : 3.2 ms								
	0111 _B : 12.8 ms								
1000 _B : 20 ms									
1001 to 1111 _B : Not permitted									
20...43	Values								
20...23	High counting limit: DWORD: Value range: -2147483648 to 2147483647 _D or 80000000 to 7FFFFFFF _H								
24...27	Comparison value 0: Operating mode Counting: DWORD: Value range: -2147483648 to 2147483647 _D or 80000000 to 7FFFFFFF _H ; Measuring operating mode: REAL: Floating point number in the configured unit of the measured variable								
28...31	Comparison value 1: Operating mode Counting: DWORD: Value range: -2147483648 to 2147483647 _D ; or 80000000 to 7FFFFFFF _H ; Measuring operating mode: REAL: Floating point number in the configured unit of the measured variable								
32...35	Start value: DWORD: Value range: -2147483648 to 2147483647 _D or 80000000 to 7FFFFFFF _H								
36...39	Low counting limit: DWORD: Value range: -2147483648 to 2147483647 _D or 80000000 to 7FFFFFFF _H								
40...43	Update time: DWORD: Value range in μs: 0 to 25000000 _D								
44	Counter behavior at limits and gate start								
44	Reaction to gate start:	Reaction to violation of a counting limit:			Reset when counting limit is violated:				
	00 _B : Set to start value	000 _B : Stop counting			000 _B : To opposite counting limit				
	01 _B : Continue with current value	001 _B : Continue counting			001 _B : To start value				
	10 to 11 _B : Not permitted	010 to 111 _B : Not permitted			010 to 111 _B : Not permitted				

A.1 Parameter assignment and structure of parameter data record

Bit →	Bit 7	Bit 6	Bit 5	Bit 4	Bit 3	Bit 2	Bit 1	Bit 0
45	Specify measured value							
45	Reserved ²⁾			Time base for velocity measurement:			Measured variable:	
				000 _B : 1 ms			00 _B : Frequency	
				001 _B : 10 ms			01 _B : Period	
				010 _B : 100 ms			10 _B : Velocity	
				011 _B : 1 s			11 _B : Not permitted	
				100 _B : 60 s/1 min				
101 to 111 _B : Not permitted								
46	Increments per unit:							
47	WORD: Value range: 1 to 65535 _D							
48	Set hysteresis range: Value range: 0 to 255 _D							
49...51	Reserved ²⁾							

- ¹ You activate the respective parameter by setting the associated bit to 1.
- ² Reserved bits must be set to 0
- ³ In isochronous mode, the parameter can affect the isochronous mode parameters of the sync domain. Because the isochronous mode parameters are not checked in RUN, overflows can occur if you change the parameter in RUN. To prevent overflows, select the option with the largest time required in the offline parameter assignment.
- ⁴ Applies to: Set function of DI = 001_B; 010_B; 011_B; 101_B

Structure of the data record 128 in Fast Mode

The following table shows you the structure of data record 128 for TM Count 1x24V for Fast Mode. The values in byte 0 to byte 3 are fixed and must not be changed.

Table A- 2 Parameter data record 128: "Fast Mode" operating mode

Bit →	Bit 7	Bit 6	Bit 5	Bit 4	Bit 3	Bit 2	Bit 1	Bit 0
Byte ↓								
0...3	Header							
0	Major Version = 0				Minor Version = 1			
1	Length of the parameter data per channel = 48							
2	Reserved ²							
3	Reserved ²							
4	Operating mode							
4	Reserved ²				Operating mode:			
					0000 _B : Not permitted			
					0001 _B : Counting / Position input			
					0010 to 1111 _B : Not permitted			
5	Basic parameters							
5	Reserved ²				Enable additional diagnostic interrupts ¹⁾		Reaction to CPU STOP:	
							00 _B : Output substitute value	
							01 _B : Keep last value	
							10 _B : Continue operation	
		11 _B : Not permitted						

A.1 Parameter assignment and structure of parameter data record

Bit →	Bit 7	Bit 6	Bit 5	Bit 4	Bit 3	Bit 2	Bit 1	Bit 0
Byte ↓	Bit 7	Bit 6	Bit 5	Bit 4	Bit 3	Bit 2	Bit 1	Bit 0
6...7	Counter inputs (parameters for incremental and pulse encoders)							
6	Sensor type:		Signal evaluation:		Signal type:			
	00 _B : Sourcing output		00 _B : Single		0000 _B : Pulse (A)			
	01 _B : Sinking output		01 _B : Double		0001 _B : Pulse (A) and direction (B)			
	10 _B : Push-pull (sinking and sourcing output)		10 _B : Quadruple		0010 _B : Count up (A), count down (B)			
	11 _B : Not permitted		11 _B : Not permitted		0011 _B : Incremental encoder (A, B phase-shifted)			
					0100 _B : Incremental encoder (A, B, N) 0101 to 1111 _B : Not permitted			
7	Reaction to signal N:		Invert direction ¹	Enable diagnostic interrupt on wire break ¹	Filter frequency ³ :			
	00 _B : No reaction to signal N				0000 _B : 100 Hz			
	01 _B : Synchronization at signal N				0001 _B : 200 Hz			
	10 to 11 _B : Not permitted				0010 _B : 500 Hz			
			0011 _B : 1 kHz					
			0100 _B : 2 kHz					
			0101 _B : 5 kHz					
			0110 _B : 10 kHz					
			0111 _B : 20 kHz					
			1000 _B : 50 kHz					
			1001 _B : 100 kHz					
		1010 _B : 200 kHz						
		1011 to 1111 _B : Not permitted						
8...9	Reserved ²							
10...15	Behavior of a DQ							
10	Set output (DQ1):				Set output (DQ0):			
	0000 _B : Digital output without function				0000 _B : Digital output without function			
	0001 _B : Between comparison value and high limit				0001 _B : Between comparison value and high limit			
	0010 _B : Between comparison value and low limit				0010 _B : Between comparison value and low limit			
	0011 _B : At comparison value for a pulse duration				0011 _B : At comparison value for a pulse duration			
	0100 _B : Between comparison value 0 and 1				0100 _B to 1111 _B : Not permitted			
	0101 to 1111 _B : Not permitted							
11	Count direction (DQ1):		Count direction (DQ0):		Reserved ²	Reserved ²	Substitute value for DQ1	Substitute value for DQ0
	00 _B : Reserved		00 _B : Reserved					
	01 _B : Up		01 _B : Up					
	10 _B : Down		10 _B : Down					
	11 _B : In both directions		11 _B : In both directions					
12	Pulse duration (DQ0):							
13	UINT: Value range in ms/10: 0 to 65535 _D							
14	Pulse duration (DQ1):							
15	UINT: Value range in ms/10: 0 to 65535 _D							

A.1 Parameter assignment and structure of parameter data record

Bit →								
Byte ↓	Bit 7	Bit 6	Bit 5	Bit 4	Bit 3	Bit 2	Bit 1	Bit 0
16	Behavior of DI0							
16	Reserved ²	Edge selection (DI0):		Select level (DI0):	Reserved ²	Set function of DI (DI0):		
		00 _B : Not permitted ⁵				000 _B : Gate start/stop (level-triggered)		
		01 _B : At rising edge		0 _B : Active with high level		001 _B : Gate start (edge-triggered)		
		10 _B : At falling edge				010 _B : Gate stop (edge-triggered)		
		11 _B : Not permitted		1 _B : Active with low level		011 _B : Synchronization ³		
						100 _B : Enable synchronization at signal N		
				101 _B : Not permitted				
		110 _B : Digital input without function						
		111 _B : Not permitted						
17	Behavior of DI1: See Byte 16							
18	Behavior of DI2: See Byte 16							
19	Frequency of synchronization:	Count direction for synchronization		Reserved ²	Input delay:			
	0 _B : Once	00 _B : Not permitted			0000 _B : None			
	1 _B : Periodic	01 _B : Up			0001 _B : 0.05 ms			
		10 _B : Down			0010 _B : 0.1 ms			
		11 _B : In both directions			0011 _B : 0.4 ms			
					0100 _B : 0.8 ms			
					0101 _B : 1.6 ms			
					0110 _B : 3.2 ms			
					0111 _B : 12.8 ms			
					1000 _B : 20 ms			
			1001 to 1111 _B : Not permitted					
20...43	Values							
20...23	High counting limit: DWORD: Value range: 1 to 33554431 _D or 1 to 01FFFFFF _H							
24...27	Comparison value 0: DWORD: Value range: 0 to 33554431 _D or 0 to 01FFFFFF _H							
28...31	Comparison value 1: DWORD: Value range: 0 to 33554431 _D or 0 to 01FFFFFF _H							
32...35	Start value: DWORD: Value range: 0 to 33554431 _D or 0 to 01FFFFFF _H							
36...39	Low counting limit: DWORD: Value range: 0 to 33554430 _D or 0 to 01FFFFFF _E _H							
40...43	Reserved ²							

A.1 Parameter assignment and structure of parameter data record

Bit →								
Byte ↓	Bit 7	Bit 6	Bit 5	Bit 4	Bit 3	Bit 2	Bit 1	Bit 0
44	Counter behavior at limits and gate start							
44	Reaction to gate start:		Reaction to violation of a counting limit:			Reset when counting limit is violated:		
	00 _B : Set to start value		000 _B : Stop counting			000 _B : To opposite counting limit		
	01 _B : Continue with current value		001 _B : Continue counting			001 _B : To start value		
	10 to 11 _B : Not permitted		010 to 111 _B : Not permitted			010 to 111 _B : Not permitted		
45...47	Reserved ²							
48	Set hysteresis range: Value range: 0 to 255 _D :							
49...51	Reserved ²							

- ¹ You activate the respective parameter by setting the associated bit to 1.
- ² Reserved bits must be set to 0
- ³ In isochronous mode, the parameter can affect the isochronous mode parameters of the sync domain. Because the isochronous mode parameters are not checked in RUN, overflows can occur if you change the parameter in RUN. To prevent overflows, select the option with the largest time required in the offline parameter assignment.
- ⁴ Applies to: Set function of DI = 001_B; 010_B; 011_B

A.2 Parameter validation error

If you make the parameter settings in STEP 7 (TIA Portal) or in STEP 7 , the parameter values are checked before they are transferred to the technology module. This process prevents parameter errors.

In other use cases, the technology module checks the transferred parameter data record. If the technology module finds invalid or inconsistent parameter values, it outputs an error code (see below). The new parameter data record is rejected in this case, and work continues with the current parameter values until a valid parameter data record has been transferred.

WRREC

When the CPU is in RUN, you can change the parameter data record with the instruction WRREC (Write Record). In case of errors, the WRREC instruction returns corresponding error codes in the STATUS parameter.

Example:

Let us assume that an invalid value, for example 9, is written to the module for the operating mode with WRREC. As a consequence, the module rejects the entire parameter data record. You can recognize this by evaluating the STATUS output parameter of the WRREC instruction. The STATUS output parameter is output as an ARRAY[1..4] of BYTE data with the value 16#DF80E111:

Example of WRREC STATUS data	Address	Meaning
DF _H	STATUS[1]	Error when writing a data record via PROFINET IO (IEC 61158-6)
80 _H	STATUS[2]	Error when reading or writing a data record via PROFINET IO (IEC 61158-6)
E1 _H	STATUS[3]	Module-specific error
11 _H	STATUS[4]	Error code from the table below: The "Operating mode" parameter has an invalid value.

Error codes

The following table shows the module-specific error codes and their meaning for parameter data record 128.

Table A- 3 Error codes for parameter validation

Error code in STATUS parameter (hexadecimal)				Meaning	Remedy
Byte 0	Byte 1	Byte 2	Byte 3		
DF	80	B0	00	Data record number unknown	Enter valid number for data record.
DF	80	B1	01	Length of data record incorrect	Enter valid value for data record length.
DF	80	B2	00	Slot invalid or not accessible	<ul style="list-style-type: none"> • Check whether module is inserted or removed. • Check assigned values for parameters of the WRREC instruction.
DF	80	E0	01	Wrong version	<ul style="list-style-type: none"> • Check byte 0. • Enter valid values.
DF	80	E0	02	Error in the header information	<ul style="list-style-type: none"> • Check byte 1. • Correct the length of the parameter blocks.
DF	80	E1	00	Parameter invalid: No detailed information available	Check all parameter values.
DF	80	E1	11	"Operating mode" parameter invalid	Enter valid parameter value.
DF	80	E1	12	"Reaction to CPU STOP" parameter invalid	Enter valid parameter value.
DF	80	E1	13	"Signal type" parameter invalid	Enter valid parameter value.
DF	80	E1	14	"Sensor type" parameter invalid	Enter valid parameter value.
DF	80	E1	15	"Filter frequency" parameter invalid	Enter valid parameter value.
DF	80	E1	16	"Reaction to signal N" parameter invalid	Enter valid parameter value.
DF	80	E1	17	"Set function of DI" parameter invalid	Enter valid parameter value.
DF	80	E1	18	"Set function of DI" parameter configured the same for DI0 and DI1.	Enter different parameter values for DI0 and DI1.
DF	80	E1	19	<ul style="list-style-type: none"> • "Edge selection" parameter invalid • "Gate start (edge-triggered)" configured as function for DI_m and "At rising and falling edge" • "Gate stop (edge-triggered)" configured as function for DI_m and "At rising and falling edge" • "Synchronization" configured as function for DI_m and "At rising and falling edge" 	<ul style="list-style-type: none"> • Enter valid parameter value. • Only configure "Gate start (edge-triggered)" as function for DI_m together with "At rising edge" or "At falling edge". • Only configure "Gate stop (edge-triggered)" as function for DI_m together with "At rising edge" or "At falling edge". • Only configure "Synchronization" as function for DI_m together with "At rising edge" or "At falling edge".
DF	80	E1	1A	"Input delay" parameter invalid	Enter valid parameter value.
DF	80	E1	1B	"Set output" parameter invalid	Enter valid parameter value.
DF	80	E1	1C	"Count direction" parameter invalid	Enter valid parameter value.
DF	80	E1	1D	"Reset when counting limit is violated" parameter invalid	Enter valid parameter value.
DF	80	E1	1E	"Reaction to violation of a counting limit" parameter invalid	Enter valid parameter value.
DF	80	E1	20	"Reaction to gate start" parameter invalid	Enter valid parameter value.

Error code in STATUS parameter (hexadecimal)				Meaning	Remedy
Byte 0	Byte 1	Byte 2	Byte 3		
DF	80	E1	21 ^{1,5}	<ul style="list-style-type: none"> Low counting limit > comparison value 0 Low counting limit > comparison value 1 	<ul style="list-style-type: none"> Low counting limit < comparison value 0 Low counting limit < comparison value 1
DF	80	E1	22 ^{1,5}	<ul style="list-style-type: none"> Counting high limit < comparison value 0 Counting high limit < comparison value 1 	<ul style="list-style-type: none"> High counting limit > comparison value 0 High counting limit > comparison value 1
DF	80	E1	23	<ul style="list-style-type: none"> "Start value" parameter invalid "Low counting limit" parameter invalid 	Enter valid parameter value: Start value > low counting limit
DF	80	E1	24	<ul style="list-style-type: none"> "Start value" parameter invalid "High counting limit" parameter invalid 	Enter valid parameter value: Start value < high counting limit
DF	80	E1	25	"Update time" parameter invalid	Enter parameter value from range 0 to 25000000 _D .
DF	80	E1	26 ²	"Reference speed" parameter invalid	Enter parameter value from range 6.00 to 210000.00 _D .
DF	80	E1	27	"Measured variable" parameter invalid	Enter valid parameter value.
DF	80	E1	28	"Time base for velocity measurement" parameter invalid	Enter valid parameter value.
DF	80	E1	29	"Increments per unit" parameter invalid	Enter valid parameter value.
DF	80	E1	2A	<ul style="list-style-type: none"> "High counting limit" parameter invalid "Low counting limit" parameter invalid 	Enter valid parameter value: Low counting limit < high counting limit
DF	80	E1	2B ³	<ul style="list-style-type: none"> "Comparison value 0" parameter invalid "Comparison value 1" parameter invalid 	Enter valid parameter value: Comparison value 0 < comparison value 1
DF	80	E1	2C	"Signal evaluation" parameter invalid	Enter valid parameter value.
DF	80	E1	2D	<ul style="list-style-type: none"> "Between comparison value 0 and 1" configured for DQ0 "Not between comparison value 0 and 1" configured for DQ0 "Between comparison value 0 and 1" configured for DQ1, but "Use by user program" not configured for DQ0 "Not between comparison value 0 and 1" configured for DQ1, but "Use by user program" not configured for DQ0 	<ul style="list-style-type: none"> Configure "Between comparison value 0 and 1" only for DQ1 "Not between comparison value 0 and 1" configured only for DQ1 Only configure "Between comparison value 0 and 1" for DQ1 when "Use by user program" is configured for DQ0 Only configure "Not between comparison value 0 and 1" for DQ1 when "Use by user program" is configured for DQ0
DF	80	E1	2E	"Capture" configured for DI _m in "Measuring" operating mode	Do not configure "Capture" for DI _m in "Measuring" operating mode
DF	80	E1	36 ⁴	"Counting high limit" parameter invalid	Enter valid parameter value.
DF	80	E1	37 ^{4,5}	<ul style="list-style-type: none"> "Comparison value 0" parameter invalid "Comparison value 1" parameter invalid 	Enter valid parameter value.
DF	80	E1	38 ⁴	"Start value" parameter invalid	Enter valid parameter value.
DF	80	E1	39 ⁴	"Counting low limit" parameter invalid	Enter valid parameter value.

Error code in STATUS parameter (hexadecimal)				Meaning	Remedy
Byte 0	Byte 1	Byte 2	Byte 3		
DF	80	E1	3A ⁴	"Count direction for synchronization" parameter invalid	Enter valid parameter value.
DF	80	E1	F0	Reserved bit is not set to 0.	Set reserved bit to 0.

- ¹ Only for "Counting" operating mode
- ² Only for "Position input for technology object "Motion Control"" operating mode
- ³ Only for DQ1 functions "Between comparison value 0 and 1" and "Not between comparison value 0 and 1"
- ⁴ Only for operating mode "Fast Mode"
- ⁵ Not for DQm function "Use by user program" or "Digital output without function"