

SIEMENS

Ingenuity for life

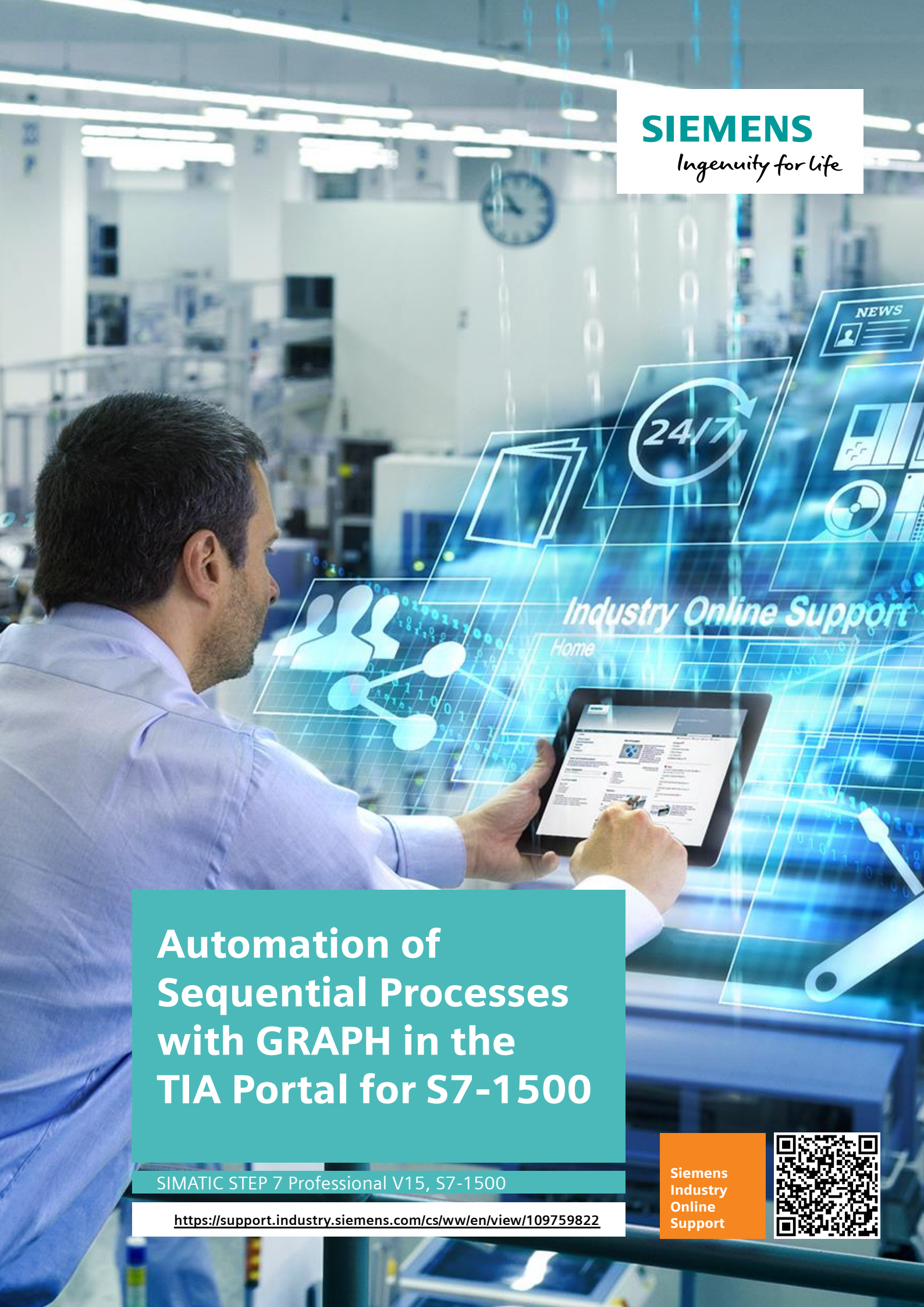

Automation of Sequential Processes with GRAPH in the TIA Portal for S7-1500

SIMATIC STEP 7 Professional V15, S7-1500

<https://support.industry.siemens.com/cs/ww/en/view/109759822>

Siemens
Industry
Online
Support



Legal information

Use of application examples

Application examples illustrate the solution of automation tasks through an interaction of several components in the form of text, graphics and/or software modules. The application examples are a free service by Siemens AG and/or a subsidiary of Siemens AG ("Siemens"). They are non-binding and make no claim to completeness or functionality regarding configuration and equipment. The application examples merely offer help with typical tasks; they do not constitute customer-specific solutions. You yourself are responsible for the proper and safe operation of the products in accordance with applicable regulations and must also check the function of the respective application example and customize it for your system.

Siemens grants you the non-exclusive, non-sublicensable and non-transferable right to have the application examples used by technically trained personnel. Any change to the application examples is your responsibility. Sharing the application examples with third parties or copying the application examples or excerpts thereof is permitted only in combination with your own products. The application examples are not required to undergo the customary tests and quality inspections of a chargeable product; they may have functional and performance defects as well as errors. It is your responsibility to use them in such a manner that any malfunctions that may occur do not result in property damage or injury to persons.

Disclaimer of liability

Siemens shall not assume any liability, for any legal reason whatsoever, including, without limitation, liability for the usability, availability, completeness and freedom from defects of the application examples as well as for related information, configuration and performance data and any damage caused thereby. This shall not apply in cases of mandatory liability, for example under the German Product Liability Act, or in cases of intent, gross negligence, or culpable loss of life, bodily injury or damage to health, non-compliance with a guarantee, fraudulent non-disclosure of a defect, or culpable breach of material contractual obligations. Claims for damages arising from a breach of material contractual obligations shall however be limited to the foreseeable damage typical of the type of agreement, unless liability arises from intent or gross negligence or is based on loss of life, bodily injury or damage to health. The foregoing provisions do not imply any change in the burden of proof to your detriment. You shall indemnify Siemens against existing or future claims of third parties in this connection except where Siemens is mandatorily liable.

By using the application examples you acknowledge that Siemens cannot be held liable for any damage beyond the liability provisions described.

Other information

Siemens reserves the right to make changes to the application examples at any time without notice. In case of discrepancies between the suggestions in the application examples and other Siemens publications such as catalogs, the content of the other documentation shall have precedence.

The Siemens terms of use (<https://support.industry.siemens.com>) shall also apply.

Security information

Siemens provides products and solutions with industrial security functions that support the secure operation of plants, systems, machines and networks.

In order to protect plants, systems, machines and networks against cyber threats, it is necessary to implement – and continuously maintain – a holistic, state-of-the-art industrial security concept. Siemens' products and solutions constitute one element of such a concept.

Customers are responsible for preventing unauthorized access to their plants, systems, machines and networks. Such systems, machines and components should only be connected to an enterprise network or the Internet if and to the extent such a connection is necessary and only when appropriate security measures (e.g. firewalls and/or network segmentation) are in place.

For additional information on industrial security measures that may be implemented, please visit <https://www.siemens.com/industrialsecurity>.

Siemens' products and solutions undergo continuous development to make them more secure. Siemens strongly recommends that product updates are applied as soon as they are available and that the latest product versions are used. Use of product versions that are no longer supported, and failure to apply the latest updates may increase the customer's exposure to cyber threats.

To stay informed about product updates, subscribe to the Siemens Industrial Security RSS Feed at: <https://www.siemens.com/industrialsecurity>.

Table of contents

Legal information	2
1 Introduction	4
1.1 Overview.....	4
1.2 Advantages	5
1.3 Requirements	5
1.4 Principle of operation.....	6
2 PLC engineering	7
2.1 Hardware configuration	7
2.2 Components used	7
2.3 Specifying the structure of the sequence cascade	8
2.4 Configuration and project planning PLC	9
2.4.1 Creating a GRAPH block.....	9
2.4.2 Creating an extension block (optional).....	11
2.4.3 Programming step actions.....	12
2.4.4 Programming instructions.....	14
2.4.5 Configuring alarms	16
2.4.6 Configuring monitoring functions in GRAPH FB	17
2.4.7 Enabling first value acquisition in GRAPH FB.....	20
2.4.8 Reset of the first faulty operands at S7-GRAPH-FB	21
2.4.9 Integration of the GRAPH FB in the STEP 7 program	23
3 HMI engineering (optional)	24
3.1 Configuring an alarm view.....	24
3.2 Configuring the GRAPH overview	25
3.3 Configuring the PLC code display	27
3.4 Calling PLC code display	28
3.5 Configuring the criteria analysis view (optional).....	30
4 Operating the application	31
4.1 Commissioning the sample project	31
4.2 Operation and diagnostics with WinCC Runtime Advanced	32
4.2.1 Simulating a fault	34
4.2.2 Reading out alarms	35
4.2.3 Acknowledging alarms	37
4.3 Controlling the sequence cascade in the GRAPH FB.....	38
5 Appendix	41
5.1 Service and Support.....	41
5.2 Links and literature	42
5.3 Change documentation	42

1 Introduction

1.1 Overview

Many applications in the area of manufacturing and process technology have sequential structures. Do you have sequential processes that must be executed in sequential processing steps? Through use of sequence cascades via GRAPH your automation solution is considerably facilitated.

The focus for use of GRAPH is on the implementation phase. The characteristic features of GRAPH can also be used optimally during the operating and maintenance phase.

GRAPH is a graphic programming language for creating sequence controls. Within a GRAPH function block you program your program in the form of sequence cascades; whereby sequential processes can be quickly programmed in a clearly organized manner.

Figure 1-1

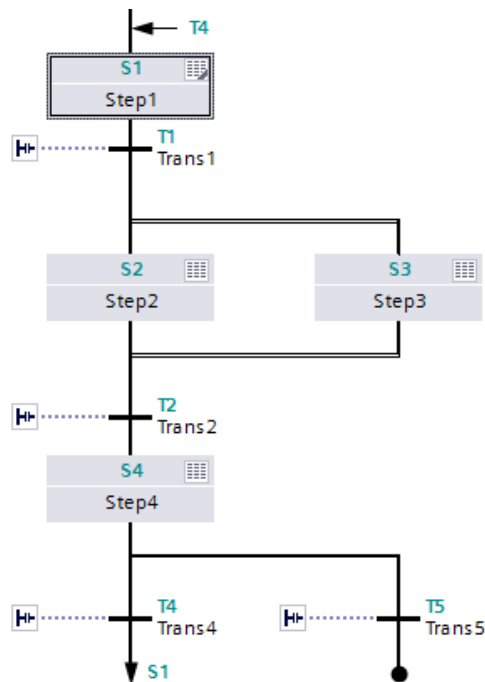

In a sequence cascade you divide the program into individual steps. In the individual steps, you determine the actions to be performed. There are transitions between the steps. In the transitions you define the conditions for advancing to the next step.

In a simple case the steps are processed linearly. However through use of alternative branches or simultaneous branches you can also generate sequence cascades with more complex structures.

1.2 Advantages

Using GRAPH offers the following advantages:

- Minimal programming effort and greater clarity through graphic programming.
- Excellent legibility for maintenance personnel.
- Less time in the commissioning phase thanks to the graphical programming interface.
- Minimal implementation effort because there are few possibilities for errors when generating code.
- High availability of the machine through process diagnostics functions (interlock and supervision).
- Fast error detection through PLC code display and criteria analysis on the HMI.

1.3 Requirements

The following requirements must be met:

- Basic knowledge of TIA Portal
- Basic knowledge of STEP 7 programming

1.4 Principle of operation

The application example provides a step-by-step description of how to automate and commission your sequential cascades in TIA Portal.

A specific example is provided using the process on the assembly machine below with a robot for placement of an object on a workpiece carrier.

Figure 1-2

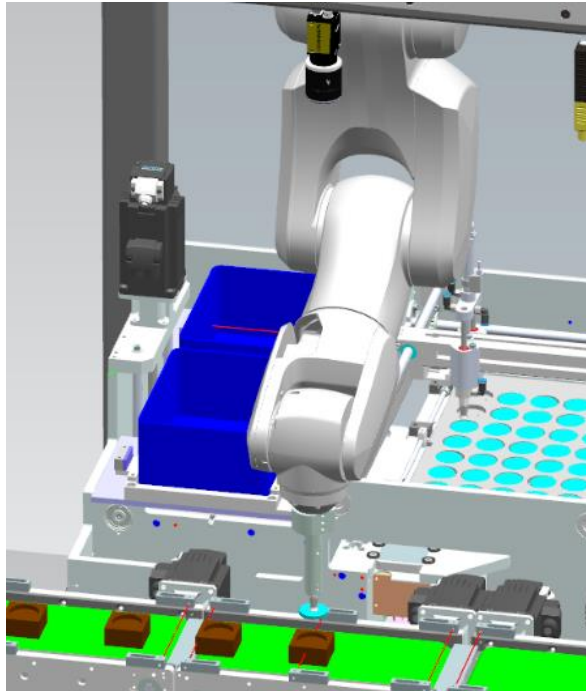

The structure is prescribed for automation of the assembly machine.

Structure of the machine

The machine consists of the following elements:

- Robot
- Conveyor belt for transport of workpieces
- Three light barriers for position detection of the workpieces

Figure 1-3

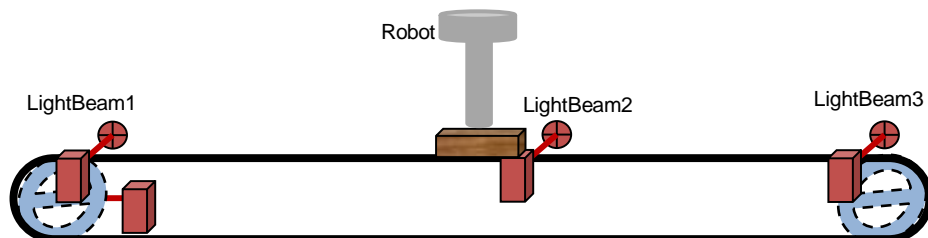

2 PLC engineering

2.1 Hardware configuration

The figure below shows the hardware with which the test was performed.

Figure 2-1

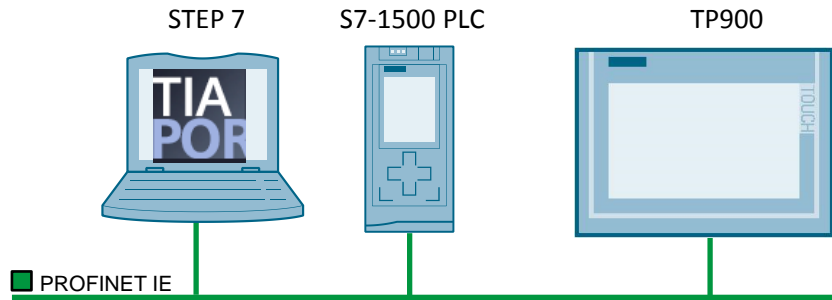

2.2 Components used

This application example was created using these hardware and software components:

Table 2-1

Component	Quantity	Article number	Note
CPU 1517-3 PN/DP	1	6ES7 517-3AP00-0AB0	Version 2.5
TP900 Comfort	1	6AV2124-0JC01-0AX0	Version 15 HMI also possible as simulation
STEP 7 Professional V15	1	6ES7822-1..05-..	-
SIMATIC WinCC Advanced V15	1	6AV2102-0AA05-0AA5	-
WinCC Runtime Professional V15	1	6AV2105-0DA05-0AA0	-

This application example consists of the following components:

Table 2-2

Component	File name
Documentation	109759822_GRAPH_TIAPortal_V15_V1.0_de.pdf
STEP 7 Project	109759822_GRAPH_Proj_TIA_Portal_V15.zip

2.3 Specifying the structure of the sequence cascade

The process of the assembly machine is described in the form of a sequence cascade. A sequence cascade is sequence of individual steps and conditions that regulate advancement to the next single step.

Organization of the process structure

The placement (assembly) process is organized in the following steps:

1. The work cycle is started via a start button.
2. The workpiece is detected on the conveyor belt at the first light barrier.
3. The workpiece is transported to the second light barrier.
4. The robot is guided to the workpiece.
5. The workpiece is fitted with a "nut".
6. The robot is brought back into home position.
7. The workpiece is transported to the last light barrier and taken off of the conveyor belt.

If a negative edge is detected at the last light barrier, the process is repeated, if a positive edge is detected, all positions are reset and the conveyor belt restarts.

Figure 2-2

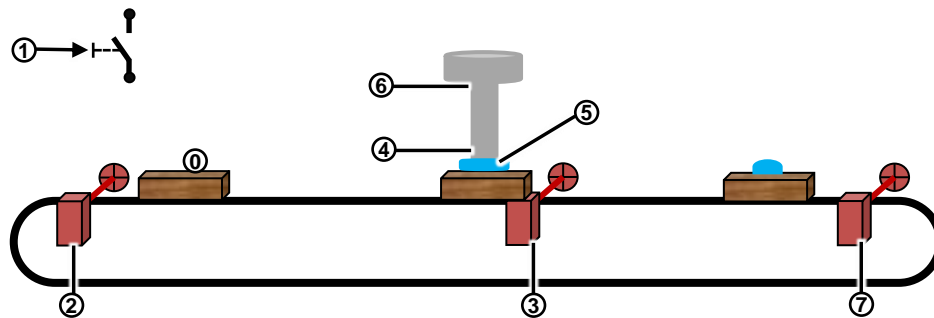

- 0: Part
- 1: Start Button
- 2: LightBeam1
- 3: LightBeam2
- 4: Robot on Station
- 5: Nut
- 6: Robot on Magazine
- 7: LightBeam3

Note There is only one workpiece on the conveyor belt in one cycle.

2.4 Configuration and project planning PLC

This section shows how to implement the process structure in a PLC program with GRAPH in the TIA Portal. To do this, the required steps, from calling the GRAPH Editor until testing the GRAPH sequence cascade, are shown.

2.4.1 Creating a GRAPH block

GRAPH blocks are created in precisely the same way that LADs / FUPs / SCLs / AWLs / STLs are created. A GRAPH block is always an FB, since FCs and OBs cannot be created in the GRAPH programming language.

Create an FB and select the GRAPH programming language.

The GRAPH Editor is started automatically after the GRAPH FB has been created, and it contains a sequence cascade with the first step (initial step) and the first transition by default.

You can switch between the following views in the GRAPH Editor navigation:

- A. Upstream (preceding) permanent pre-instruction
- B. Sequence view
- C. Single step view
- D. Downstream (post) permanent post-instruction
- E. Alarm view

Figure 2-3

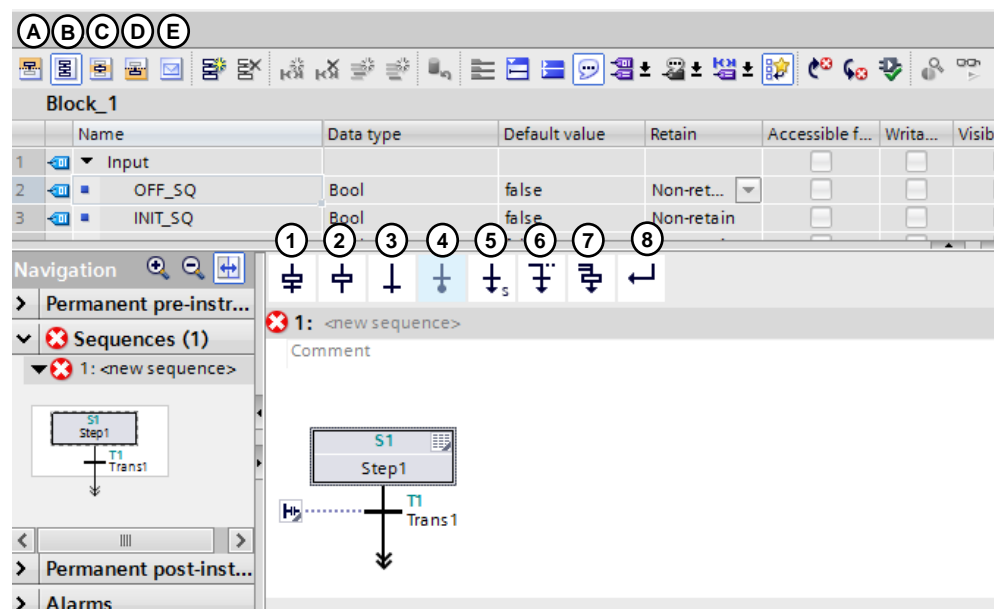

The Sequence view shows you the structure of the GRAPH sequence cascade and it likewise includes a Favorites bar. The Favorites are already created there; these are favorites with which you extend the GRAPH sequence cascade with the following elements:

1. Step and transition
2. Step
3. Transition
4. Sequence end
5. Jump
6. Open alternative branch (OR branch)
7. Open simultaneous branch (AND branch)
8. Close branch

To insert a new element in your sequence cascade, drag the desired element via drag & drop from the Favorites or the "Instructions" task card to the appropriate point of the sequence cascade.

To edit the element in the GRAPH FB, proceed as follows:

1. Open the sequence view in the navigation.
2. Select the step to be edited.
3. Click "Single step view".
4. Click "Actions".
5. Edit the action.
6. Edit the conditions for the transition.

Figure 2-4

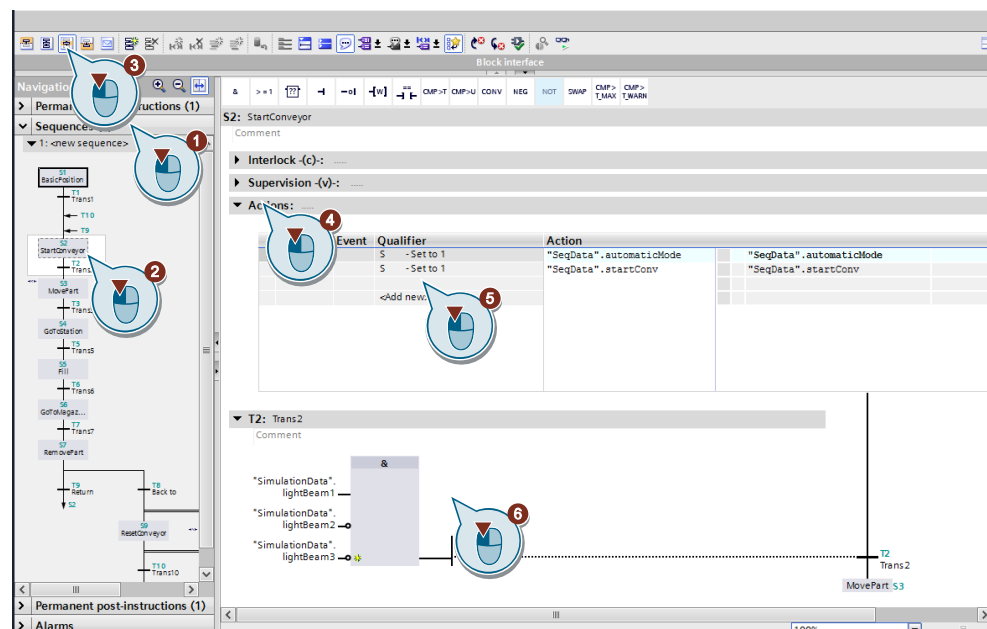

Note

Within the extension block, you can access the internal GRAPH parameters. The specific description arrays and state arrays are included in the group-array "io-G7Arrays" and the accesses occur via the offsets.

2.4.2 Creating an extension block (optional)

In addition, you can create an extension block and assign it to the GRAPH FB in order to access the internal visible or invisible parameters of the GRAPH FB. For this GRAPH FB version 4.0 or higher must be used.

To create an extension block, proceed as follows:

1. Create an FB in the SCL programming language.
2. In the interface of the created FB, under "InOut" enter the following parameters:
 - "InOutRTData", data type "G7_RTDataPlus_Vx"
 - "InOutG7T", data type "Array[*] of G7_TransitionPlus_Vx"
 - "InOutG7S", data type "Array[*] of G7_StepPlus_Vx"
 - "InOutG7Arrays", data type "Array[*] of USInt"

The block interface must conform to the specifications. The version Vx must match the version of the GRAPH block.

3. Open the properties of the GRAPH FB and under Attributes, enter the name of the extension block.
4. Instantiate the extension block either as single-instance or multi-instance. The actual call of the extension block occurs automatically from GRAPH and does not need to be programmed manually.
 - **Single-instance:**
Create an instance DB of the extension block type and in the GRAPH FB, under "InOut" define a parameter that has the extension block as data type.
 - **Multi-instance**
In the GRAPH FB, in the interface under "Static" define a parameter that has the extension block as data type.

Figure 2-5

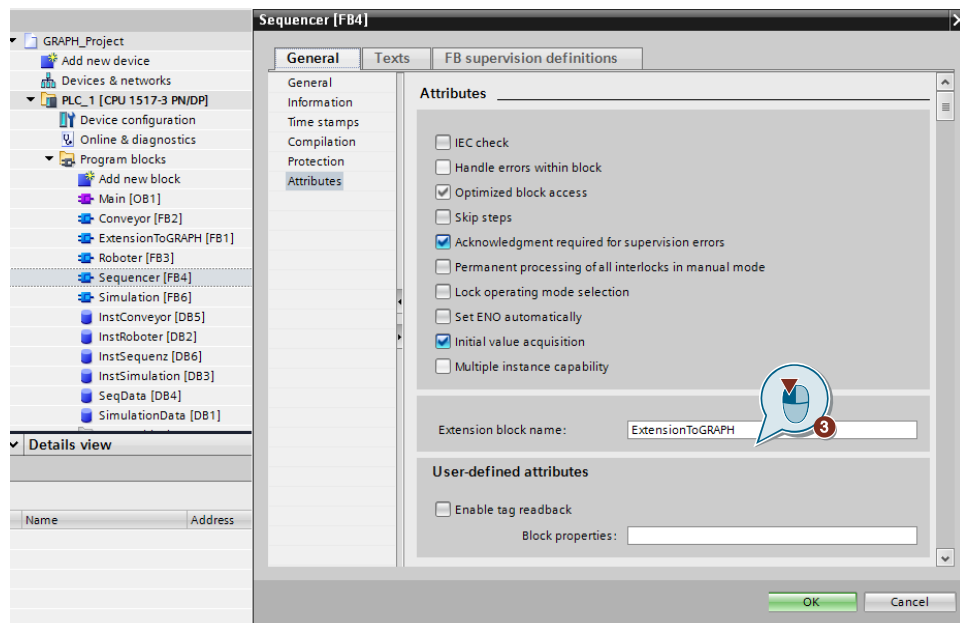

Note

Additional information concerning the standard behavior of GRAPH FBs is provided under "Basic information on extending the standard behavior of GRAPH (S7-1500)".
<https://support.industry.siemens.com/cs/ww/en/view/109755202/95307728907>

2.4.3 Programming step actions

With actions you can control inputs and outputs, enable or disable other steps of the sequence cascade, or call blocks.

The instructions that are programmed in the actions will be executed at step enable or when an event that is linked to the action occurs. The actions will be executed in sequence top to bottom.

An action consists of the following components:

- Action (mandatory)
- Qualifier (mandatory)
- Event optional
- Interlock (optional)

To insert an action in the single step view, proceed as follows:

1. Open the Single Step View.
2. Click the small arrow in front of "Actions" to expand the actions.
3. In the "Qualifier" column select the qualifier that the new action should have.
4. In the "Action" column, select the action that should be executed. You have the following options:
 - Replace the place holder with the operands that you want to use.
 - Drag the instructions from the task card into the "Action" column via drag & drop.
 - Via drag & drop, drag the blocks from the project navigation into the "Action" column, to call them.
5. If you want to link the new action to an interlock, click in the Interlock line and select the entry "-(C)".
6. If you want to link the new action to an event, click in the "Event" line and select the appropriate event.

Figure 2-6

The screenshot displays the Siemens STEP 7 software interface. At the top, there is a toolbar with various icons for navigation and editing. Below the toolbar, the project tree shows 'S3: Step3'. The main workspace is divided into several sections. On the left, there are sections for 'Interlock', 'Event', and 'Qualifier'. The 'Action' section contains the following SCL code:

```
#start
#remove
CALL RD_SYS_T DATE_AND_TIME
  (RET_VAL => #tagError
  OUT => #dateTime
  )
```

On the right side, there is a pane titled 'Basic instructions' and 'Extended instructions'. Under 'Extended instructions', there is a sub-section 'Date and time-of-day' which contains a list of instructions. A red arrow points to the instruction 'RD_SYS_T DATE_AND_TIME' in this list.

You can use SCL expressions directly in the actions. An action block with instructions always requires the qualifier "N".

Note

Additional information concerning actions is provided under:

"Standard actions"

<https://support.industry.siemens.com/cs/ww/en/view/109755202/66267461643>

"Event-dependent actions"

<https://support.industry.siemens.com/cs/ww/en/view/109755202/50149342731>

2.4.4 Programming instructions

With the instructions and the transitions you program the following components of your GRAPH program:

Permanent instructions

Via permanent instructions (preceding instructions and post-instructions), you can create program code that is executed either before or after processing of the sequence cascade. Permanent instructions are programmed in a GRAPH FB within networks.

In order for you to program a permanent instruction, at least one network must be present. You can create a maximum of 250 networks in preceding permanent instructions and 250 permanent post-instructions in a GRAPH FB.

The permanent instructions will be executed at each GRAPH block call.

Figure 2-7

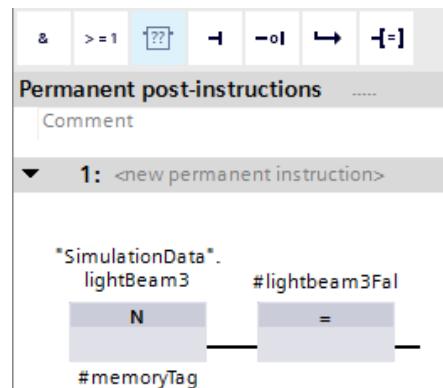

Transitions

You can use up to 32 instructions in your transition network, on which a maximum of 32 operands are interconnected. Transitions can only be programmed in LAD/FUP.

To program transitions, proceed as follows.

1. Open the sequence view.
2. Click the small arrow in front of "Transition number" to expand the transition network.
3. Drag the required instructions to the desired point in the network.
4. Enter the conditions that are required to advance from one step to the next.

Figure 2-8

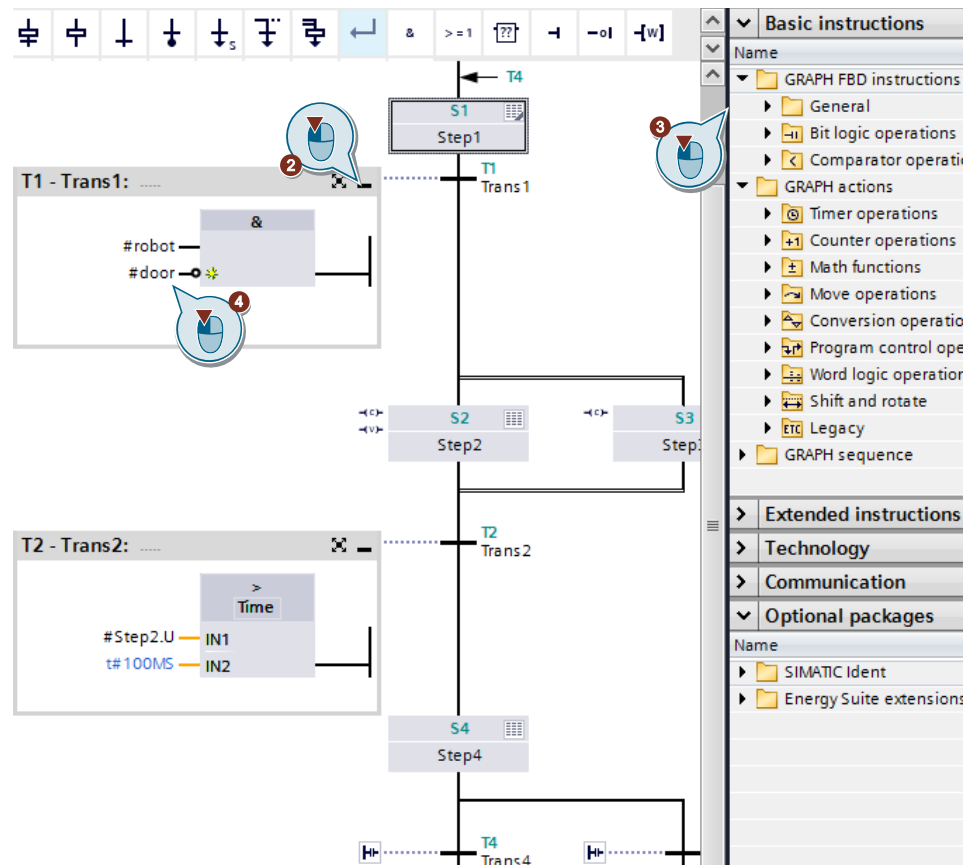

When programming comparators you can use system information for steps as operands. In this regard the operands have the following meaning:

- Step name.T: Current or last activation time of the step
- Step name.U: Current or last activation time of the step without the time of a fault

2.4.5 Configuring alarms

You can configure alarms in order to quickly identify, precisely locate, and correct errors during process execution. You can activate the Alarm display globally for new GRAPH FBs or locally for individual blocks.

Global enable of the alarms

To enable the alarm display globally for new GRAPH FBs, proceed as follows:

1. In the "Options" menu, select the "Settings" command.
2. In the Navigation area, select the group "PLC Programming > GRAPH".
3. In the "Default settings for new blocks", activate the option check box "Enable alarms".

Figure 2-9

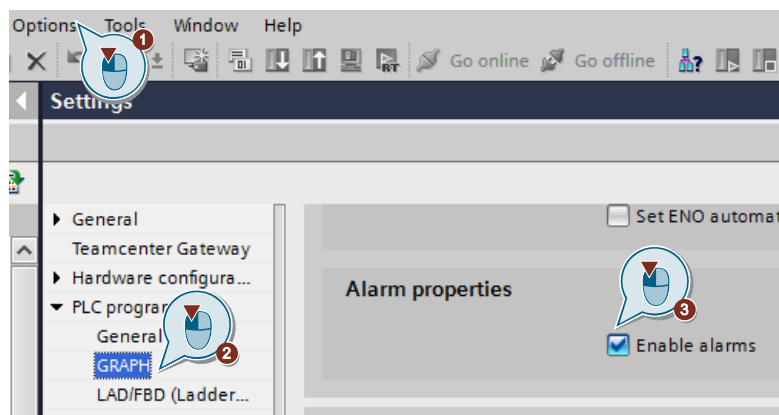

Local activation of the specific alarms

To enable the Alarm display for an existing GRAPH FB, proceed as follows:

1. Open the Alarm view in the GRAPH FB.
2. In the "Alarms" area, activate the check box "Enable alarms".

Figure 2-10

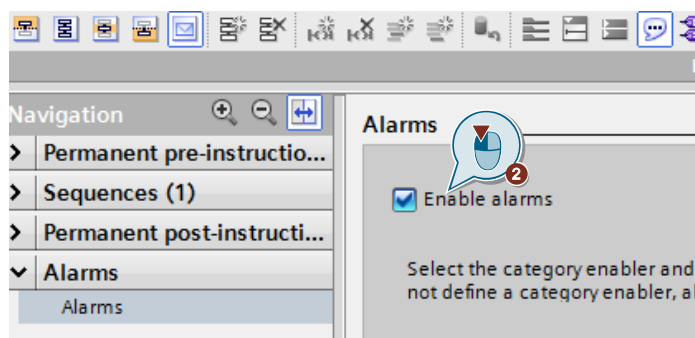

2.4.6 Configuring monitoring functions in GRAPH FB

You can uncover faults via interlock and supervisions. To quickly rectify these faults you have the option of specifying alarms that describe the faults in detail.

Interlock

An action marked with "C" will only be executed when the interlocking condition of the step applies ("C" = TRUE).

Execution of instructions that are locked with interlock is prevented, but advancing to the next step is not prohibited. An acknowledgment is not required.

A locking error occurs when the condition is FALSE. In this case the action conditioned with "C" will not be executed.

The step will be marked in orange and the error message "Interlock Error" will be generated.

You can use up to 32 instructions in your interlock network, on which a maximum of 32 operands are interconnected. Interlocks can only be programmed in LAD/FUP.

To program interlocks, proceed as follows:

1. Open the step in the Single step view.
2. Click on the small arrow in front of "Interlock -(C)-" to open the interlock network.
3. Drag the required instructions to the desired point in the network.
4. Enter the conditions that are required for the interlock.
5. In the Action table, click in the "Interlock" column, and in the drop-down box click the entry "- (C) - Interlock" in the cell of the action that you want to link to the interlock.

Fig. 2-11

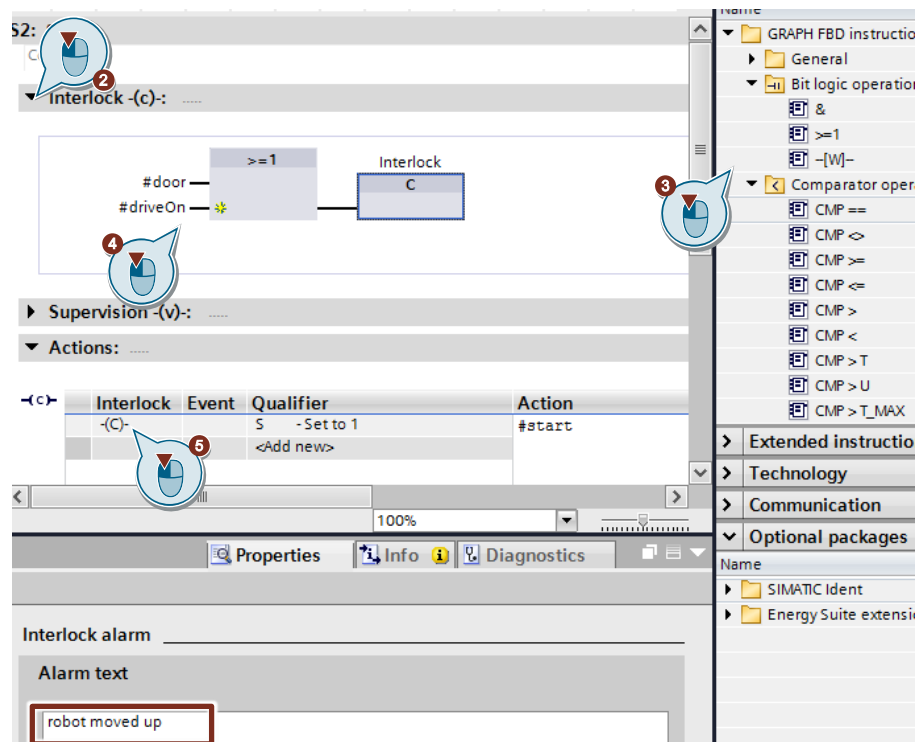

To input a specific alarm text, select the interlock and select "Properties". Then in the text entry field "Alarm Text", click the desired alarm text.

To display the specific alarm text in multiple languages, proceed as follows:

1. Right click the "Sequencer" FB.
2. In the context menu select "Properties".
3. In the "Texts" tab enter the desired alarm text in the enabled foreign language.

Figure 2-12

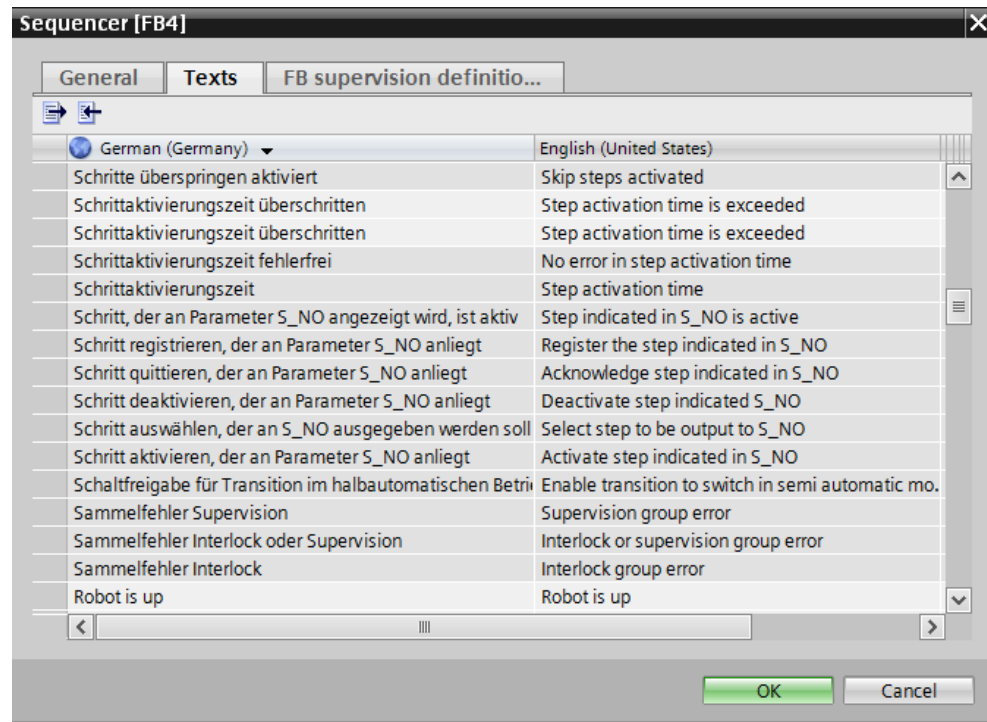

Supervision

A fault is present when the condition is true and the step does not advance. Execution of the actions in the step is not hindered, but advancing to the next step is. Unlike the situation for interlock, in this case acknowledgment is required. The step is marked in red and the error message "Supervision Error" is generated. You can use up to 32 instructions in your supervision network, on which a maximum of 32 operands are interconnected. Supervision can only be programmed in LAD/FUP.

To program supervision, proceed as follows:

1. Open the step in the Single step view.
2. Click the small arrow in front of "Supervision -(V)-" to open the supervision network.
3. Drag the required instructions to the desired point in the network.
4. Specify the conditions that are required for supervision.

Figure 2-13

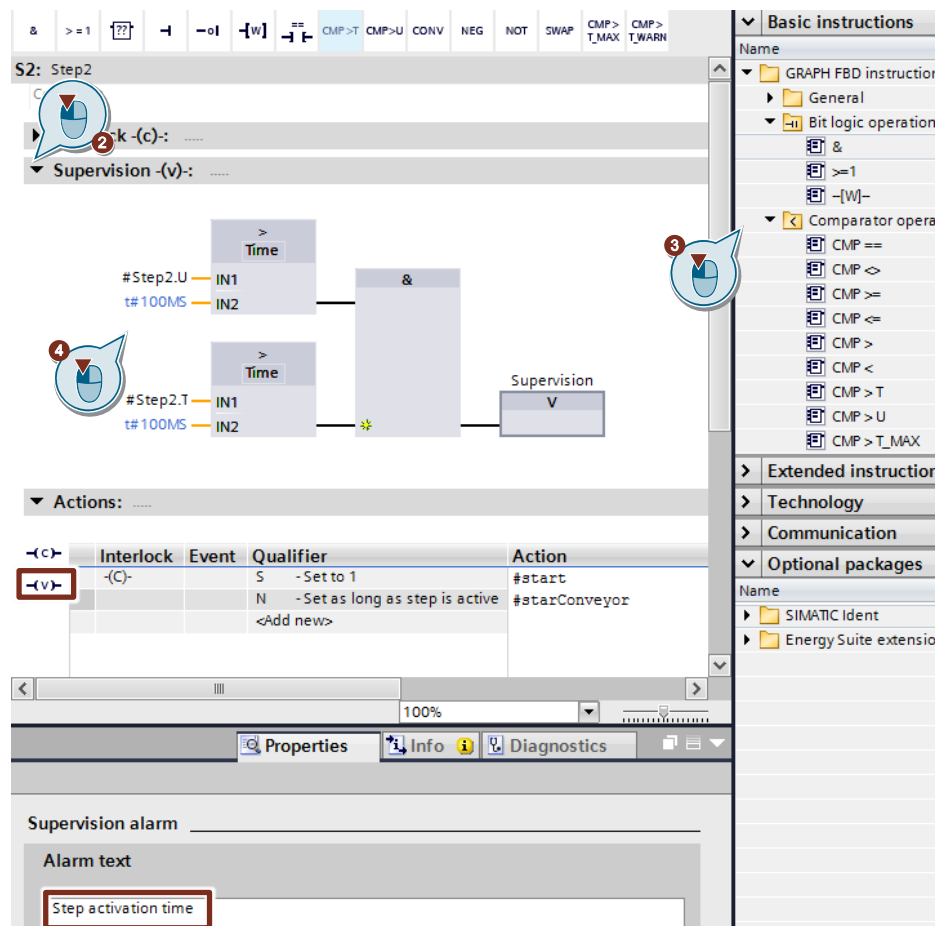

Entry of alarm texts functions the same manner as described for interlock.

2.4.7 Enabling first value acquisition in GRAPH FB

With first value acquisition, signal states at the time of the fault can be recorded in the controller. You have the option of tracking the execution of the user program on an HMI device. The data on the HMI device is continuously synchronized and updated with the CPU.

Each individual signal state occupies one bit and the values are stored in a DWORD in the GRAPH instance DB.

GRAPH FB version 4.0 or higher must be used to activate first value acquisition.

To activate first value acquisition, proceed as follows:

1. Open the properties of the GRAPH FB "Sequencer" [FB4].
2. In the "General > Block" tab select version V4.0 or V5.0.
3. Click the tab "Attributes".
4. Enable "Initial value acquisition" and confirm with OK.

Figure 2-14

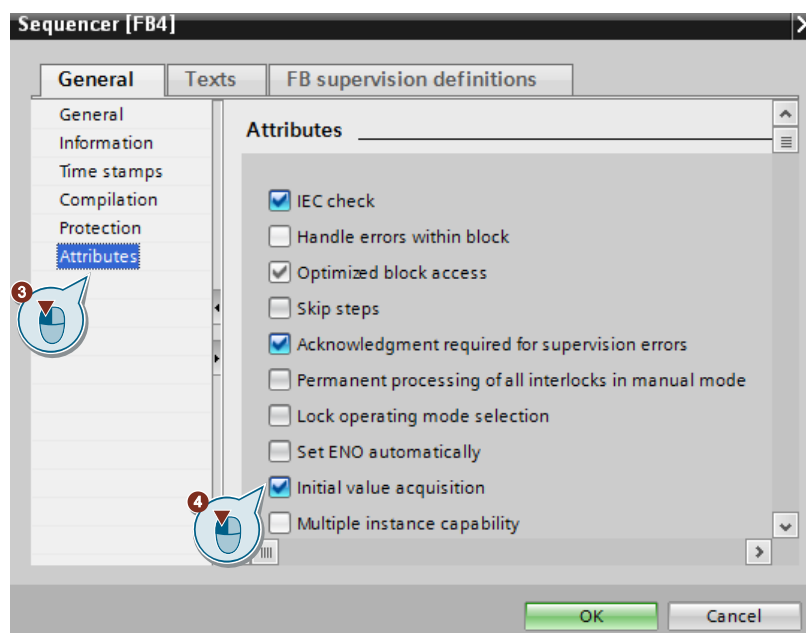

Recording of the initial values starts as soon as the user program is compiled and loaded. With the PLC code display you can visualize the initial values on your HMI device.

Further information is provided under [PLC Code Display](#)

2.4.8 Reset of the first faulty operands at S7-GRAPH-FB

Using the S7-GRAPH-FB, from V5.0 with the aid of the input parameter "RESET_CRIT" you can reset the signal state of the two static parameters "H_IL_ERR" and "H_SV_FLT" to FALSE after the criteria analysis.

This is useful if you change the programming of interlocks and transitions and no longer need the initial values that thus become out-of-date. The signal states are not automatically reset to FALSE by the programming change.

To enable the input parameter "RESET_CRIT", proceed as follows:

1. Open the GRAPH FB "Sequencer" [FB4] and enable the two functions:
 - "Edit > Interface parameters > Maximum interface parameters" and
 - "Edit > Internal parameters visible/accessible from HMI"
2. Open the OB "Main" and right-click the GRAPH FB "Sequencer" [FB4].
3. Select "Update block call" from the context menu. After the update, the GRAPH FB is displayed with its maximum parameters.
4. Define a DB variable, e.g. "SeqData.resetCrit" with the data type Bool and assign the parameter "RESET_CRIT" of the GRAPH FB with the DB variable.

Figure 2-15

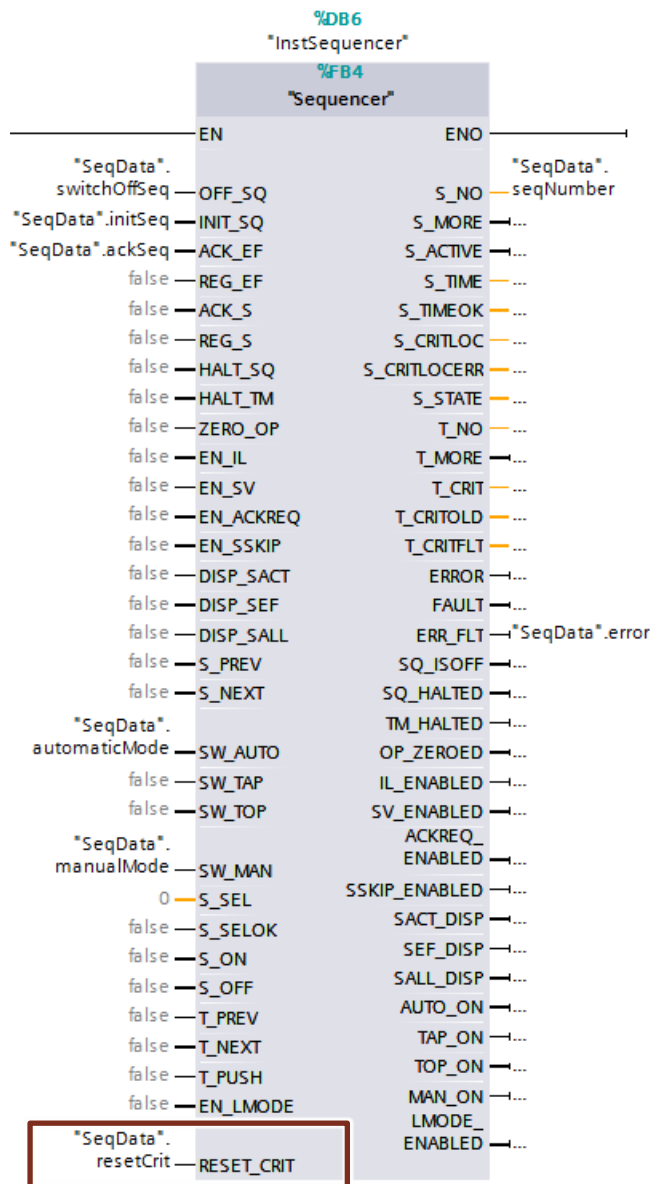

© Siemens AG 2018. All rights reserved.

Note After changing the block parameter in the GRAPH FB the visibility / accessibility of the internal parameters are automatically disabled by the HMI.

The parameters of the GRAPH FBs must be visible in the HMI and must be accessible from the HMI, so that the program status of the GRAPH FB can be displayed with "GRAPH Overview".

Further information is provided under [GRAPH overview](#)

In the "Edit" menu bar, enable the "Internal parameters visible/accessible from HMI". Selection is only possible if the GRAPH FB is open and in focus in the editor.

2.4.9 Integration of the GRAPH FB in the STEP 7 program

So that the sequence cascade is executable, it is called and started in a block. GRAPH knows three models of the FB call, as presented in the table below. How to change the settings is provided under "[Reset of the first faulty operands on the S7-GRAPH-FB](#)".

Table 2-3

Maximum interface parameter	Standard interface parameter	Minimum interface parameter
<p style="text-align: center;">%DB6 "InstSequencer" %FB4 "Sequencer"</p> <p>EN → ENO →</p> <p>*SeqData*.switchOffSeq — OFF_SEQ → S_NO — seqNumber</p> <p>*SeqData*.initSeq — INIT_SEQ → S_MORE → ...</p> <p>*SeqData*.ackSeq — ACK_EF → S_ACTIVE → ...</p> <p>false — REG_EF → S_TIME → ...</p> <p>false — ACK_S → S_TIMEOK → ...</p> <p>false — REG_S → S_CRITLOC → ...</p> <p>false — HALT_SEQ → S_CRITLOCERR → ...</p> <p>false — HALT_TM → S_STATE → ...</p> <p>false — ZERO_OP → T_NO → ...</p> <p>false — EN_IL → T_MORE → ...</p> <p>false — EN_SV → T_CRIT → ...</p> <p>false — EN_ACKREQ → T_CRITOLD → ...</p> <p>false — EN_SSKIP → T_CRITFLT → ...</p> <p>false — DISP_SACT → ERROR → ...</p> <p>false — DISP_SEF → FAULT → ...</p> <p>false — DISP_SALL → ERR_FLT → *SeqData*.error</p> <p>false — S_PREV → SQ_ISOFF → ...</p> <p>false — S_NEXT → SQ_HALTED → ...</p> <p>*SeqData*.automaticMode — SW_AUTO → TM_HALTED → ...</p> <p>false — SW_TAP → OP_ZEROED → ...</p> <p>false — SW_TOP → IL_ENABLED → ...</p> <p>*SeqData*.manualMode — SW_MAN → SV_ENABLED → ...</p> <p>0 — S_SEL → ACKREQ → ENABLED → ...</p> <p>false — S_SELOK → SSKIP_ENABLED → ...</p> <p>false — S_ON → SACT_DISP → ...</p> <p>false — S_OFF → SEF_DISP → ...</p> <p>false — T_PREV → SALL_DISP → ...</p> <p>false — T_NEXT → AUTO_ON → ...</p> <p>false — T_PUSH → TAP_ON → ...</p> <p>false — EN_LMODE → TOP_ON → ...</p> <p>*SeqData*.resetCrit — RESET_CRIT → LMODE_ENABLED → ...</p>	<p style="text-align: center;">%DB6 "InstSequencer" %FB4 "Sequencer"</p> <p>EN → ENO →</p> <p>*SeqData*.switchOffSeq — OFF_SEQ → S_NO — seqNumber</p> <p>*SeqData*.initSeq — INIT_SEQ → S_MORE → ...</p> <p>*SeqData*.ackSeq — ACK_EF → S_ACTIVE → ...</p> <p>false — S_PREV → ERR_FLT → *SeqData*.error</p> <p>false — S_NEXT → AUTO_ON → ...</p> <p>*SeqData*.automaticMode — SW_AUTO → TAP_ON → ...</p> <p>false — SW_TAP → TOP_ON → ...</p> <p>false — SW_TOP → MAN_ON → ...</p> <p>*SeqData*.manualMode — SW_MAN → ...</p> <p>0 — S_SEL → ...</p> <p>false — S_ON → ...</p> <p>false — S_OFF → ...</p> <p>false — T_PUSH → ...</p>	<p style="text-align: center;">%DB6 "InstSequencer" %FB4 "Sequencer"</p> <p>EN → ENO →</p> <p>*SeqData*.initSeq — INIT_SEQ → ...</p>

3 HMI engineering (optional)

The TIA Portal contains various objects, with which the current alarms are displayed. You can integrate these objects in your HMI screen.

3.1 Configuring an alarm view

Current alarms are shown in an alarm display in runtime.

To configure an alarm display, proceed as follows:

1. Open the "Diagnostic" screen under the folder "Screens > Application > AutomationOfSequentialOperationsGRAPH > Diagnostic".
2. Drag the object "Alarm view" from the task card "Tools > Controls" ("Toolbox > Controls") into the screen.
3. Select the alarm display and activate the alarm classes "Acknowledgment" and "No Acknowledgment" under "Properties > Properties > General".
4. Select "Properties > Properties > Display"
5. Under "Control tag for criteria analysis view", select the control variable of the criteria analysis view.

Note

If you do not yet have a variable, create an internal variable of the type [WSTRING] for criteria analysis view.

6. For the "Control tag for PLC code view", select the control variable of the PLC code display.

Note

If you do not yet have a variable, create an internal variable of the type [WSTRING] for criteria analysis view.

Note

Steps 4 to 6 are only required, if you are using the criteria analysis view and the PLC code display.

Figure 3-1

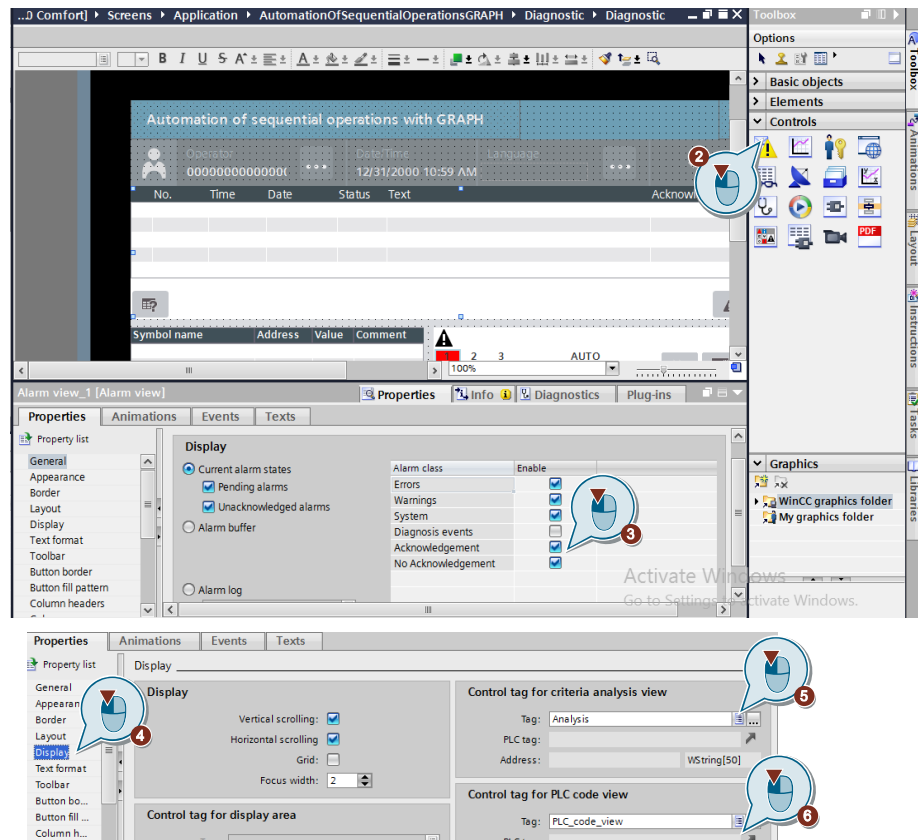

3.2 Configuring the GRAPH overview

The GRAPH overview shows you the current program status for executed steps in a GRAPH process sequence cascade.

To configure a GRAPH overview, proceed as follows:

1. Drag the "GRAPH overview" object from the "Tools > Controls" task card ("Toolbox > Controls") into the "Diagnostic" screen.
2. Select the "GRAPH overview" and click "Properties > Properties > General".
3. Open the selection dialog under "Variable" ("Tag") and select the PLC variable "OFF_SQ" from the GRAPH instance database.

Note

If you cannot see the variable "OFF_SQ", check whether the parameters from the HMI are visible/accessible. Further information in this regard is provided under "[Internal parameters visible/accessible from HMI](#)".

4. Change the presentation of the object under "Properties > Properties > Layout".

Figure 3-2

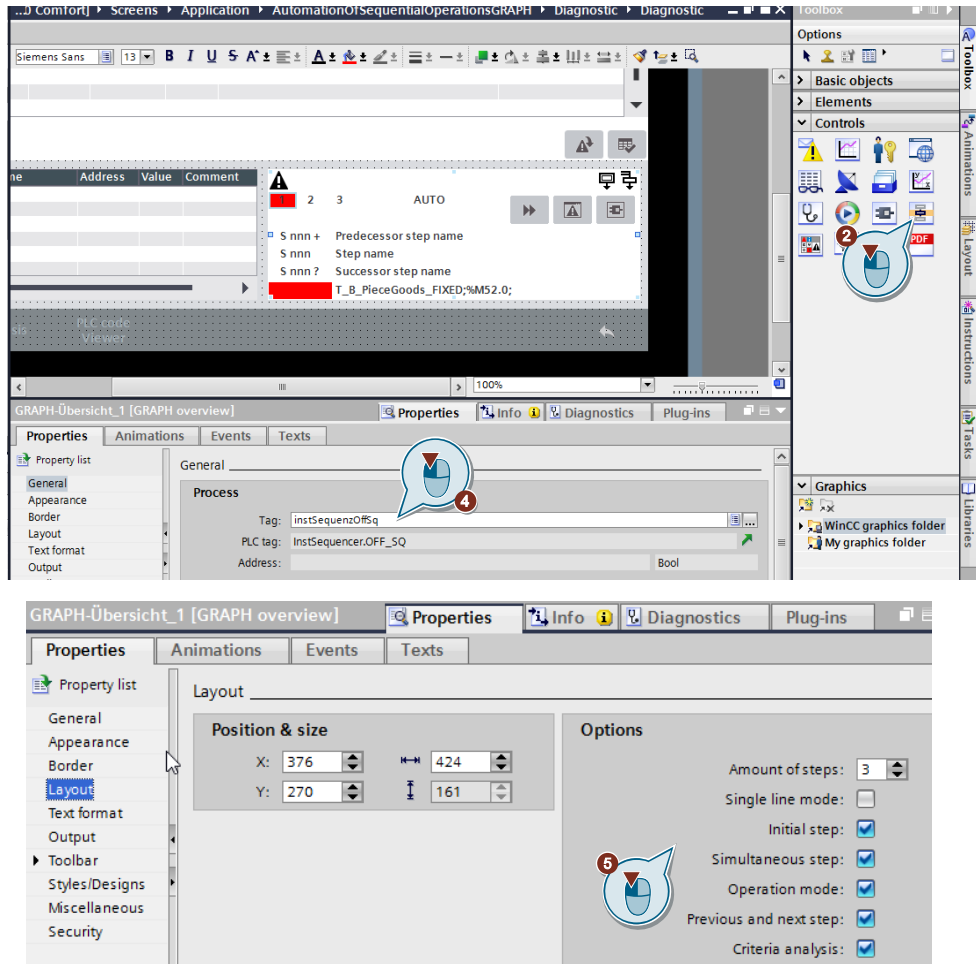

3.3 Configuring the PLC code display

The PLC code display shows the current program status of the user programs programmed in LAD, FUP or GRAPH. Errors in the GRAPH sequence cascade are displayed directly at the corresponding step.

To configure a PLC code display, drag the "PLC code view" object from the "Task Card > Tools > Controls" ("Toolbox > Controls") into the "PLCCodeViewer" screen.

Figure 3-3

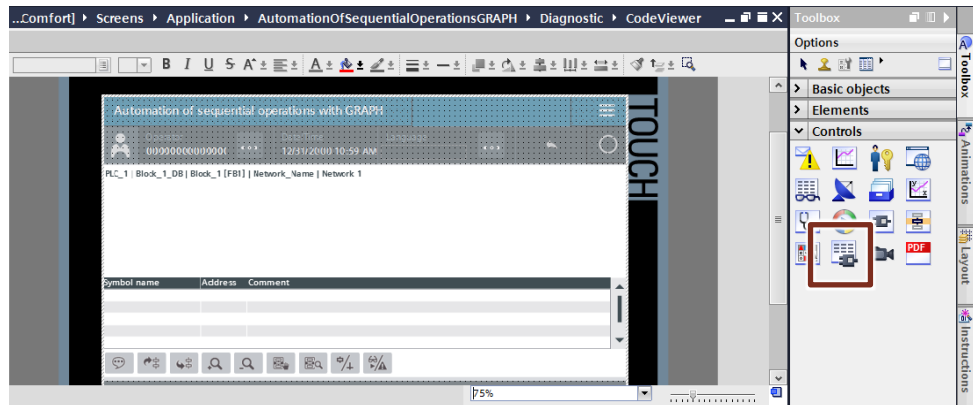

3.4 Calling PLC code display

You can call the PLC code display with a button or via the GRAPH overview.

To call the PLC code display via a button, proceed as follows:

1. Open the "TemplateDiagnosis" screen in the "Screen management > Template" folder.
2. Insert the "Button" object from the "Tools > Elements" task card into the screen.
3. Select the button and click "Properties > Events > Activate".
4. Insert the system function "ActivatePLCodeDisplay" and set the following parameters:
 - a. Screen name: "PLCCodeViewer"
 - b. Screen object: "PLC code display_1"

Figure 3-4

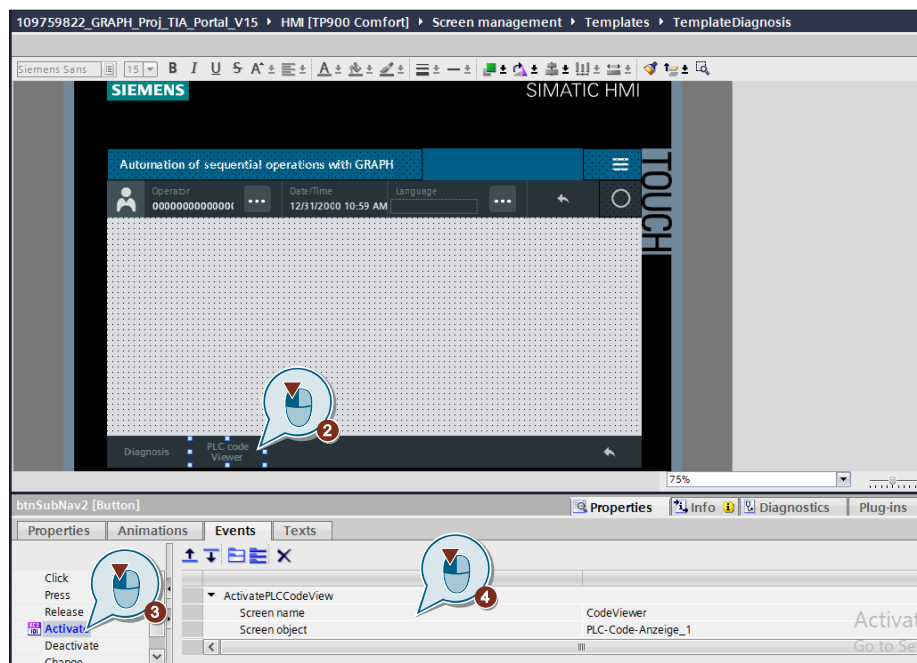

3 HMI engineering (optional)

To call the PLC code display via the GRAPH overview, proceed as follows:

1. Open the "Diagnostic" screen.
2. Select the "Graph overview" and click "Properties > Properties > Toolbar".
3. Under "General", enable the "Show PLC code view button".

Figure 3--5

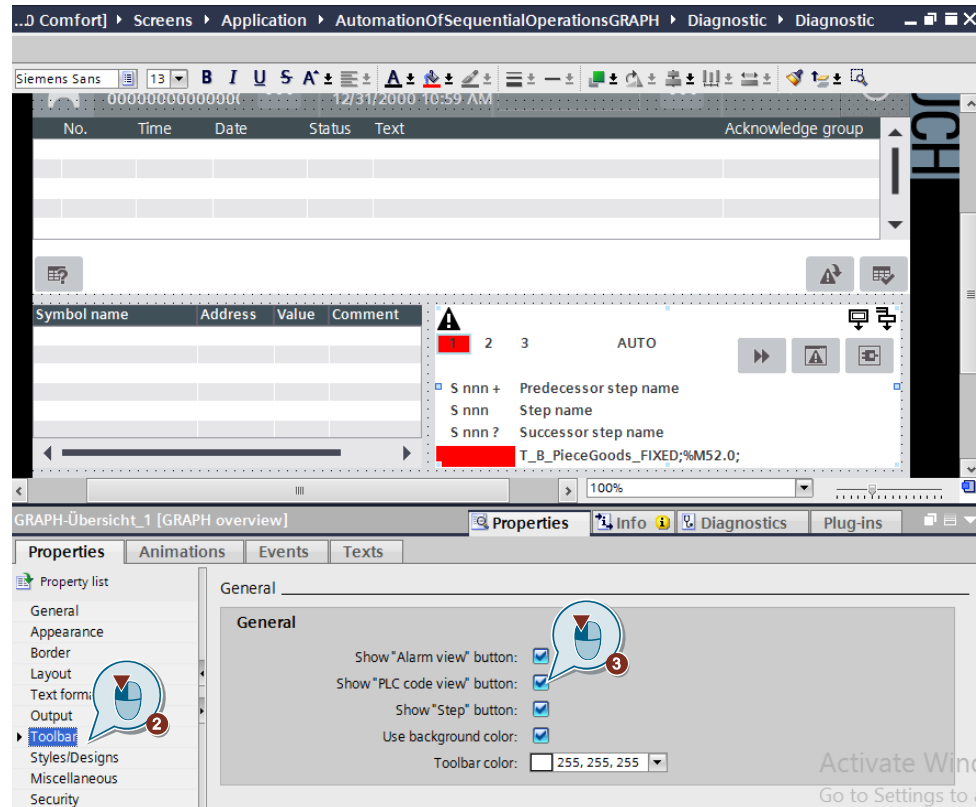

3.5 Configuring the criteria analysis view (optional)

The criteria analysis view shows the faulty operands in the user program. In addition to the alarms, you can also see the list of faulty operands. To establish the connection to the corresponding alarms, the Alarm display is connected to the criteria analysis view via a control variable.

To configure a criteria analysis view, proceed as follows:

1. Drag the object "criteria analysis view" from the "Tools > Controls" task card ("Toolbox > Controls") into the "Diagnostic" screen.
2. Select the "criteria analysis view" and click "Properties > Properties > General".
3. Select the status variable of the corresponding alarm display under "Process > Variable" ("Process > Tag"). If you do not yet have one, create an internal variable of the type "WString".

Figure 3-5

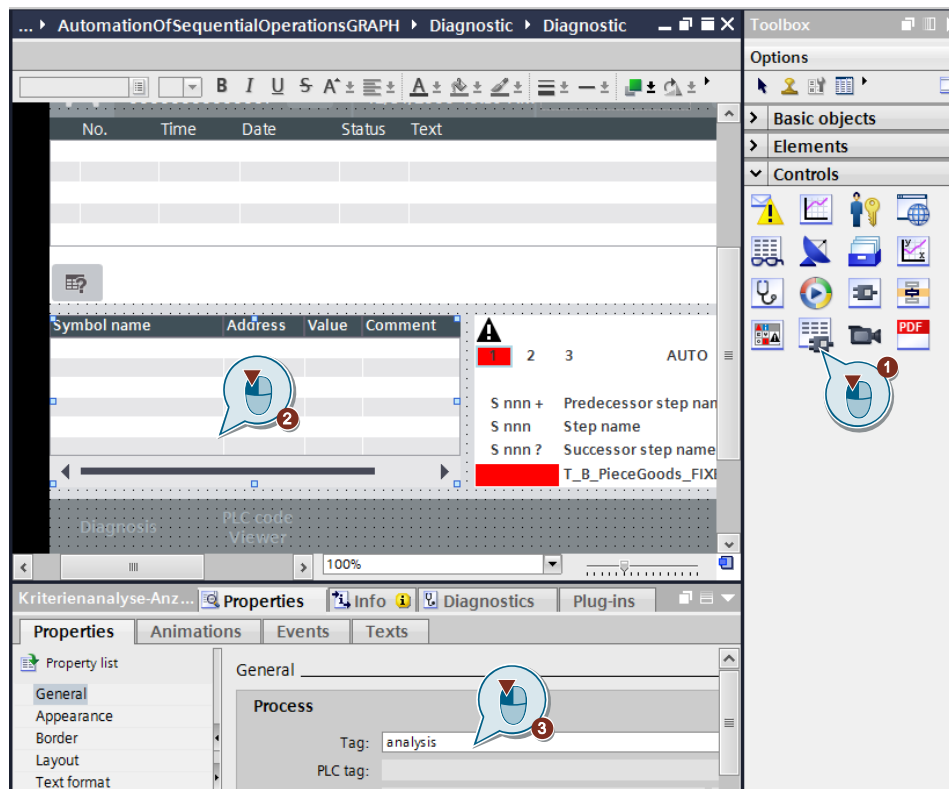

4 Operating the application

This section shows you how to commission and operate the application example. The provided STEP 7 project requires no further configuration and can be commissioned.

4.1 Commissioning the sample project

Load the prefabricated STEP 7 project into your controller. To do this proceed as follows:

1. Load the download file "109759822_GRAPH_Proj_TIA_Portal_V15.zip" onto your hard disk. The download is provided on the Entry page of the application example <https://support.industry.siemens.com/cs/ww/en/view/109759822>
2. Unpack the compressed download file.
3. Dearchive the project in TIA Portal.
4. Select the "PLC_1" folder in the project navigation and click the "Download to device" button in the toolbar.
5. Select the folder "HMI [TP900 Comfort]" in the project navigation and click the button "Start Simulation" in the toolbar.

Note

Load the GRAPH blocks in the STOP operating state, since the sequence cascade will be automatically set to the initial state after the instance DB has been loaded.

Only load GRAPH blocks in the RUN operating state if the sequence cascade is in the initial state or in the OFF state. Problems can occur when overwriting an old block when synchronizing the sequence cascade with the process.

4.2 Operation and diagnostics with WinCC Runtime Advanced

To test the user program, an online connection to the CPU is established and the CPU is in "RUN" mode.

The conveyor belt is operated and diagnosed directly in the TIA Portal with WinCC Runtime Advanced.

The Figure below shows the user interface of the application.

Figure 4-1



4 Operating the application

The table below shows the steps required to operate the application:

Table 4-1

Screen no.	Description	Action
1.	Shows the Start screen, with which the application can be started.	Click the "Start application" button to go to the application.
2.	Contains a brief description of the project and information on how the application is operated.	Click on the "Conveyor belt" screen to open the application.
3.	Displays the conveyor belt with the robot, the active step number and the buttons for diagnostics and fault simulation.	Click the button: <ul style="list-style-type: none"> • "Diagnostics" to display alarms. See Read-out alarm. • "Supervision" to simulate errors. See Simulate fault. • "Acknowledgment", to acknowledge errors. See Acknowledge alarm. • "CRIT" to reset the initial values of transition/step. • "Right page navigation" to operate the GRAPH sequence cascade.
4.	Contains the operation of the conveyor belt.	Click the button: <ul style="list-style-type: none"> • "Start" to start the GRAPH sequence cascade. • "Initialize" to initialize the GRAPH sequence cascade. • "Switch-off" to switch-off the GRAPH sequence cascade, i.e. disable all steps. • "Close right page navigation" to hide the page navigation.
5.	Shows the Alarm display, the GRAPH overview, the display of the criteria analysis, and the "PLC code display" button that activates the PLC code display.	You are on the "Diagnostics" screen and an error is present. Select from the following controls to obtain detailed information concerning the error: <ul style="list-style-type: none"> • "Alarm display", to display the actual error message. • GRAPH overview to display the error directly on the appropriate step. • Criteria analysis display to display the faulty operands. • PLC code display to open the configured PLC code display.
6.	Shows the PLC code display	When an error occurs, proceed as follows: <ul style="list-style-type: none"> • Select the error message in the Alarm display • Click the "PLC code display" button to go to the PLC code display and see the error location in the program.

4.2.1 Simulating a fault

A monitoring time is programmed in step 7. If the step activation time exceeds the maximum monitoring time (T_MAX) in the supervision condition, then the system will detect a monitoring error and the faulty step will be marked red.

Figure 4-2

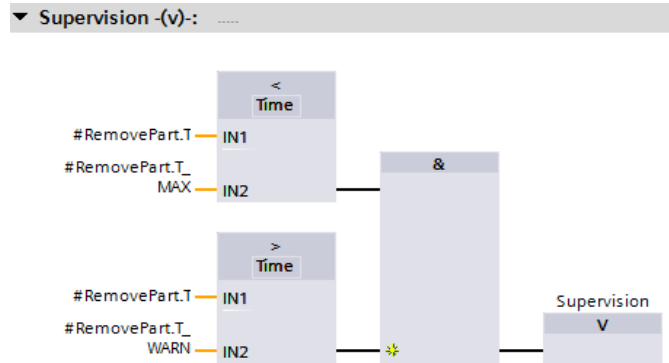

To trigger the monitoring error, wait until step 7 is active and click the Supervision button "Simulate". Step 7 will be marked red and the GRAPH sequence cascade does not advance.

Note

The conveyor belt continues to run because it is not controlled by the GRAPH sequence cascade.

Figure 4-3

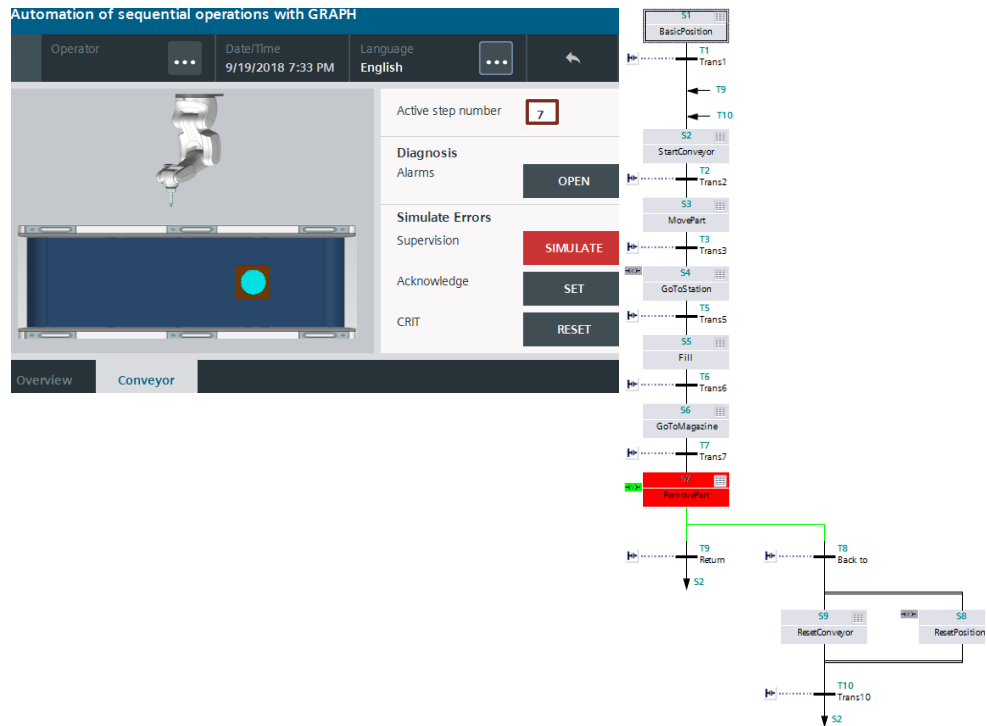

4.2.2 Reading out alarms

To read the alarms and to view the first faulty operand, proceed as follows:

1. Click the "Open" button in the "Conveyor belt" screen to switch to the "Diagnostic" screen.

The Alarm display shows the error message of the supervision. The step number marked in red in the GRAPH overview signals the error in the GRAPH sequence cascade. The faulty operand is displayed in the criteria analysis, as well as in the GRAPH overview.

2. Select the GRAPH monitoring alarm in the Alarm display.
3. Click the "PLC code display" button or the small symbol for PLC code display in the GRAPH overview to go to the "PLC code display" screen.

Figure 4-4

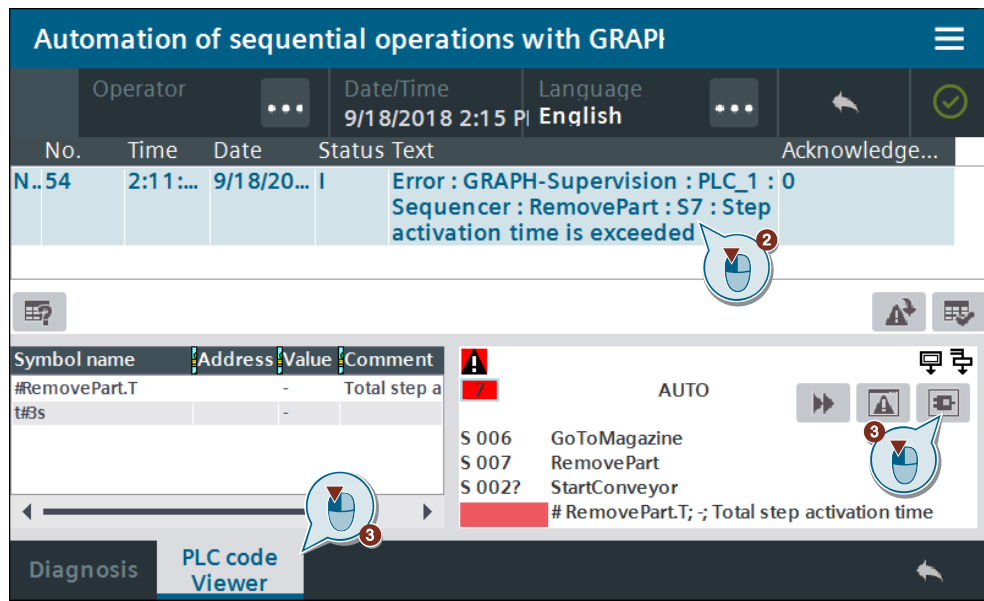

The interrupted step is shown in the GRAPH sequence cascade.

You see the trigger of the supervision in the transition network. One of the two conditions is fulfilled (step enable time has been exceeded).

Figure 4-5

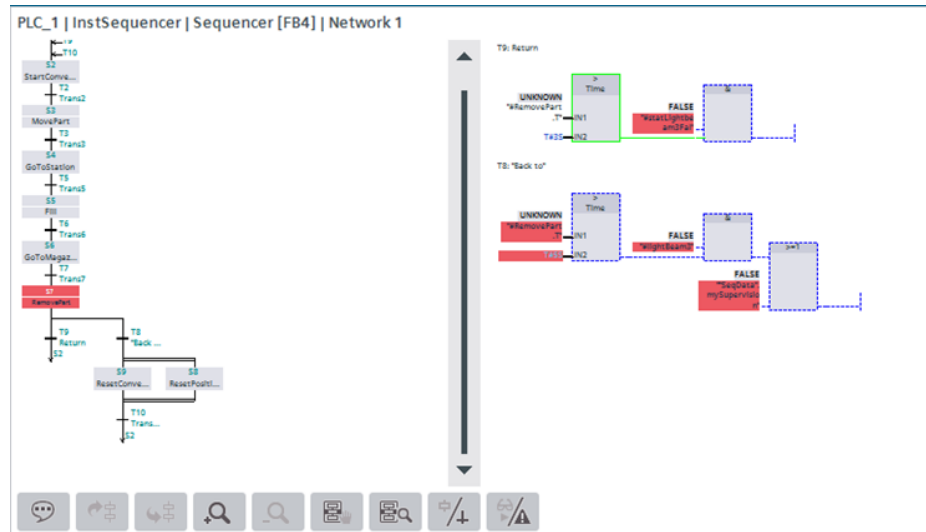

4. Click the "Actual values / Initial values" button to switch between the Actual values and Initial values views.

Figure 4-6

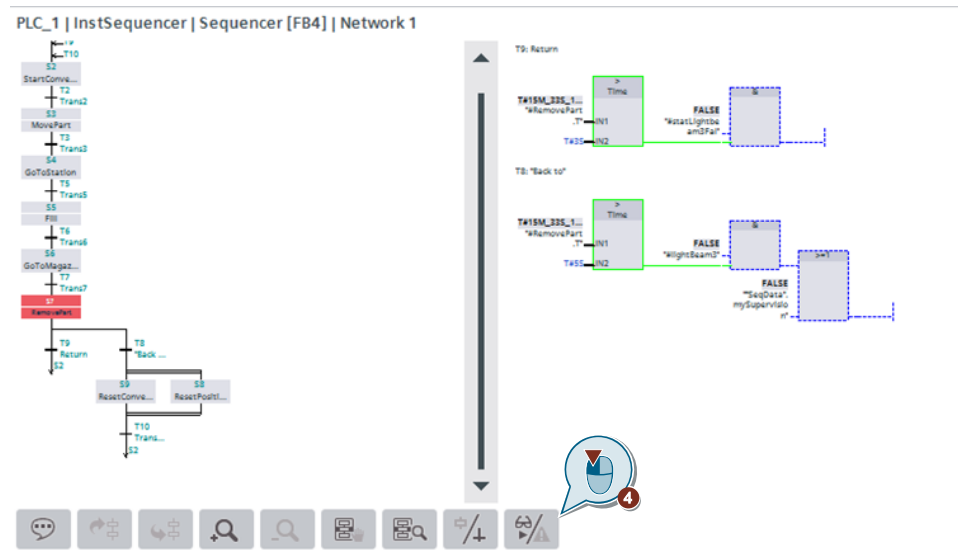

The signal states are stored per cycle in the GRAPH instance DB.

The actual values are stored in the parameters

- "CRIT" for transitions
- "CRIT_LOC" for step

As soon as an error occurs the values will be copied into the parameters CRIT_FLT and CRIT_LOC_ERR (step). The initial values remain unchanged in the active step until a new error occurs.

Figure 4-7

InstSequenz					
	Name	Data type	...	Monitor value	Comment
▶	Trans5	G7_TransitionPlus_...			Transition structure
▶	Trans6	G7_TransitionPlus_...			Transition structure
▶	Trans7	G7_TransitionPlus_...			Transition structure
▶	Back to	G7_TransitionPlus_...			Transition structure
▼	Return	G7_TransitionPlus_...			Transition structure
■	TV	Bool	fa:	FALSE	Transition is valid
■	TT	Bool	fa:	FALSE	Transition is satisfied
■	TS	Bool	fa:	FALSE	Transition switches
■	TNO	Int	9	9	Indicates the user-defined transio
■	CRIT	DWord	16	16#0000_0003	Status of the maximum 32 LAD/FBD
■	CRIT_OLD	DWord	16	16#0000_0002	Status of the maximum 32 LAD/FBD
■	CRIT_FLT	DWord	16	16#0000_0002	Copy of CRIT if an error occurs

4.2.3 Acknowledging alarms

To acknowledge the received fault, you must first fulfill the condition necessary for advancement. You can then acknowledge the error via the "Acknowledge" button.

4.3 Controlling the sequence cascade in the GRAPH FB

To control the GRAPH sequence cascade directly in the GRAPH FB, proceed as follows:

1. Open the GRAPH FB.
2. Enable the "Monitoring on/off" button.
3. Open the test card "Testing".
4. In the "Sequence control" palette select one of the following buttons:
 - a. Initialize
 - b. Deactivate all steps (Deactivate all)
 - c. Acknowledge supervision error (Acknowledge -(V)-)
 - d. Set operating mode (Mode)
 - e. Learning mode for step activation time

Figure 4-8

The screenshot displays the Siemens STEP 7 software interface. On the left, a ladder logic diagram for a sequencer is shown, starting with a 'BasicPosition' step (S1) and proceeding through transitions T1 to T10 to steps S2 through S7, and finally to S9 and S8. On the right, the 'Testing' options panel for the 'Sequencer [FB4]' block is visible. The 'Sequence control' section contains several buttons and options: 'Initialize' (a), 'Deactivate all' (b), 'Acknowledge -(V)-' (c), and 'Mode' (d) with radio buttons for 'Automatic', 'Semiautomatic mode', and 'Manual mode'. The 'Learning mode for step activation time' section (e) includes an 'Enable learning mode' checkbox and a 'Supervision threshold (%)' field.

Initialize

With the "Initialize button" you can completely restart the sequence cascade with the defined initial steps.

Deactivate all steps

With the button "Deactivate all steps" you can deactivate all steps of the sequence cascade.

Acknowledging supervision errors

With the "Acknowledge" button you can acknowledge a queued message, if the option "Acknowledge required" is switched on.

Before acknowledging the fault, ensure that the monitoring conditions that resulted in the fault are no longer met.

Setting operating modes

You can test the sequence cascade in the following operating modes:

- **Automatic mode**
The sequence cascade switches automatically to the next step, as soon as the transition is complete.
- **Semiautomatic mode**
The sequence cascade switches to the next step, when one of the following conditions is met:
 - Transition is complete.
 - A rising signal edge is present at parameter "T_PUSH".
 - You advance manually.
- **Manual mode**
In this operating mode you can either switch from one step to the next manually, or select a specific step.
 - Enter the step number of the step that you want to process, in the "Step number" field or simply click the desired step.
 - Select the action (activate or deactivate) that should be executed with the step.

System synchronization

In manual mode the situation can arise that the process is no longer synchronous with the sequence cascade. To resynchronize the process and the sequence cascade you can search for synchronization points and then execute the synchronization. You can choose from the following methods:

- **Previous transition fulfilled**
All steps, with a preceding transition that is fulfilled, will be marked
- **Interlock fulfilled**
All steps, whose interlocks are fulfilled, will be marked
- For both methods only steps will be marked for which the subsequent transition is not fulfilled.

Learning mode for step activation time

You can use the learning mode to have the system determine the values for the maximum step activation time "T_MAX" and the warning time "T_WARN" for the total duration of a step.

The maximum step activation time and the warning time are made up of the learned time and a limit value. You specify the limit values for supervision and warning yourself.

$$T_MAX = \text{learned time} + (\text{limit value} * \text{learned time})$$

$$T_WARN = \text{learned time} + (\text{limit value} * \text{learned time})$$

To determine "T_MAX" and "T_WARN", proceed as follows:

1. Enter the limit value for the supervision and for the warning in percent.
2. Activate the check box "Enable learning mode".
3. Wait until each step was active at least once.
4. Disable the option box "Enable learning mode".
5. The dialog window "Save learned times" will open. Click "OK" to save the learned times in the offline instance DB.
6. Click the button "Reset learned times" to reset the saved learned times.

Figure 4-9

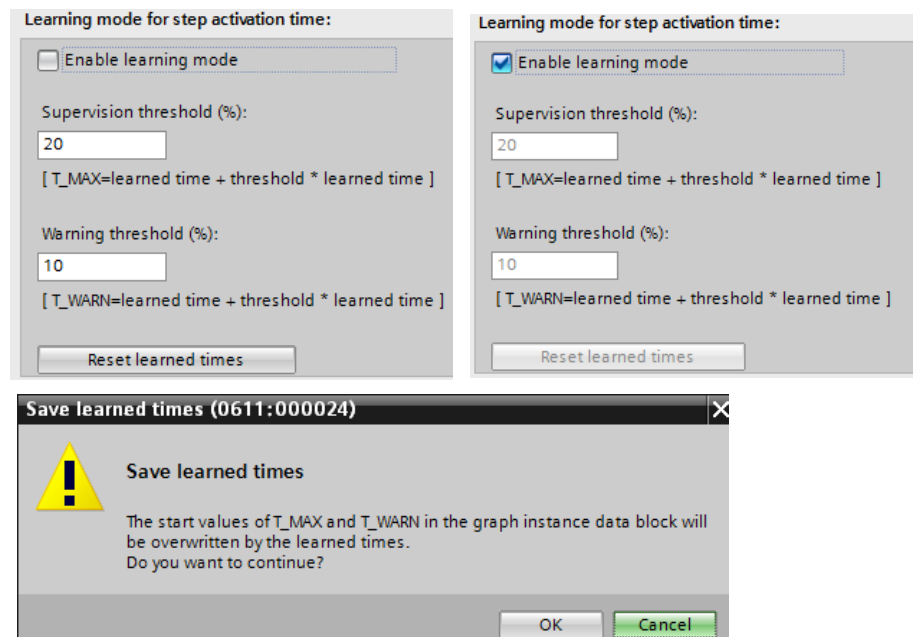

You can monitor the step enable time using the statements `CMP>T_MAX` and `CMP>T_WARN`. For example, you compare the activation time of a step with the measured times.

In the application example, the activation time at step 7 is compared with "T_MAX" and "T_WARN".

5 Appendix

5.1 Service and Support

Industry Online Support

Do you have any questions or need assistance?

Siemens Industry Online Support offers round the clock access to our entire service and support know-how and portfolio.

The Industry Online Support is the central address for information about our products, solutions and services.

Product information, manuals, downloads, FAQs, application examples and videos – all information is accessible with just a few mouse clicks at:

<https://support.industry.siemens.com>

Technical Support

The Technical Support of Siemens Industry provides you fast and competent support regarding all technical queries with numerous tailor-made offers – ranging from basic support to individual support contracts. Please send queries to Technical Support via Web form:

www.siemens.com/industry/supportrequest

SITRAIN – Training for Industry

We support you with our globally available training courses for industry with practical experience, innovative learning methods and a concept that's tailored to the customer's specific needs.

For more information on our offered trainings and courses, as well as their locations and dates, refer to our web page:

www.siemens.com/sitrain

Service offering

Our range of services includes the following:

- Plant data services
- Spare parts services
- Repair services
- On-site and maintenance services
- Retrofitting and modernization services
- Service programs and contracts

You can find detailed information on our range of services in the service catalog web page:

<https://support.industry.siemens.com/cs/sc>

Industry Online Support app

You will receive optimum support wherever you are with the "Siemens Industry Online Support" app. The app is available for Apple iOS, Android and Windows Phone:

<https://support.industry.siemens.com/cs/ww/en/sc/2067>

5.2 Links and literature

Table 5-1

No.	Topic
\1\	Siemens Industry Online Support https://support.industry.siemens.com
\2\	Link to the article page of the application example https://support.industry.siemens.com/cs/ww/en/view/109759822
\3\	Manual "SIMATIC STEP 7 Basic/Professional V15 and SIMATIC WinCC V15": https://support.industry.siemens.com/cs/ww/en/view/109755202

5.3 Change documentation

Table 5-2

Version	Date	Change
V1.0	09/2018	First version