

SIEMENS

Ingenuity for life

Industry Online Support

Home

Use of encoders with the speed monitor 3TK2810-1

SIRIUS / Safety Integrated

<https://support.industry.siemens.com/cs/ww/en/view/109764784>

Siemens
Industry
Online
Support



This entry is from the Siemens Industry Online Support. The general terms of use (http://www.siemens.com/terms_of_use) apply.

Security information

Siemens provides products and solutions with industrial security functions that support the secure operation of plants, systems, machines and networks. In order to protect plants, systems, machines and networks against cyber threats, it is necessary to implement – and continuously maintain – a holistic, state-of-the-art industrial security concept. Siemens' products and solutions only form one element of such a concept. Customer is responsible to prevent unauthorized access to its plants, systems, machines and networks. Systems, machines and components should only be connected to the enterprise network or the internet if and to the extent necessary and with appropriate security measures (e.g. use of firewalls and network segmentation) in place. Additionally, Siemens' guidance on appropriate security measures should be taken into account. For more information about industrial security, please visit <http://www.siemens.com/industrialsecurity>.

Siemens' products and solutions undergo continuous development to make them more secure. Siemens strongly recommends to apply product updates as soon as available and to always use the latest product versions. Use of product versions that are no longer supported, and failure to apply latest updates may increase customer's exposure to cyber threats. To stay informed about product updates, subscribe to the Siemens Industrial Security RSS Feed under <http://www.siemens.com/industrialsecurity>.

Table of content

1	Use of encoders with the speed monitor 3TK2810-1	3
	1.1 Question	3
	1.2 Answer.....	3
2	Contact/ Support.....	6

1 Use of encoders with the speed monitor 3TK2810-1

1.1 Question

What needs to be considered when using encoders with the speed monitor 3TK2810-1?

1.2 Answer

No special safety encoders are needed when using the safety-related speed monitor 3TK2810-1.

In the event of the use of encoders the FIT-value (Failure in Time) must be included in the calculation of the safety chain. Encoders which are use with the safety-related speed monitor 3TK2810-1 must have the following distinctive characteristics:

- TTL/ HTL encoders which provide two signal traces with each an inverted signal.
- All sin/cos encoders which provide both the sinus and the cosinus trace with each an inverted signal (sin, /sin and cos, /cos).
- The phase shift of both signal A (or sin) and B (or cos) must be 90 °, between A and /A resp. B and /B it must be 180 °.
- The signals of the encoder must become high-impedance in the event of failure. That means: The appropriate trace provides a resistance of at least 170 kOhm.

A disturbing shift of the signal trace resp. the mutual overtaking of the sin/cos-signals is identified by the speed monitor 3TK2810-1. The detection of the fault is independent of the adjusted frequency. The safety-related speed monitor 3TK2810-1 switches into a safe state and indicates an error message. It is the responsibility of the user to check whether a certain encoder and its pin assignment matches the safety-related speed monitor 3TK2810-1.

In order to detect the standstill resp. the speed of the motor, the speed (frequency) is measured on the basis of two NPN or PNP proximity switches (device version with NAMUR sensors) or via encoders (sin/cos, TTL, HTL) with two signal traces und its inverted traces. (See figure " Example for signal waveform TTL-/HTL-level")

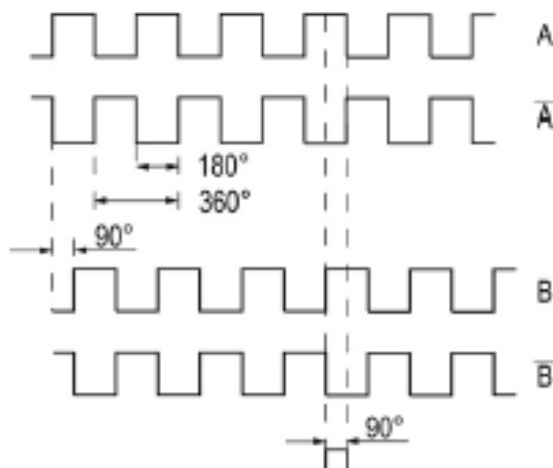

Figure 1: Example for signal waveform TTL-/HTL-level

It is also possible to combine encoders and NPN / PNP proximity switches / NAMUR sensors.

Requirements related to the encoder

Design: exclusively with 2 signal traces with each an inverted signal (A, /A, B, /B)

Phase shift of the signal traces:

- A: 0 degree
- B: 90 degree (referred to A)
- /A: 180 degree (referred to A, inverted A)
- /B: 270 degree (referred to A, inverted B)

Output: TTL
HTL
sin/cos (UA = 1VPP (differential signal A to /A resp. B to /B),
UOffset = 2,5V

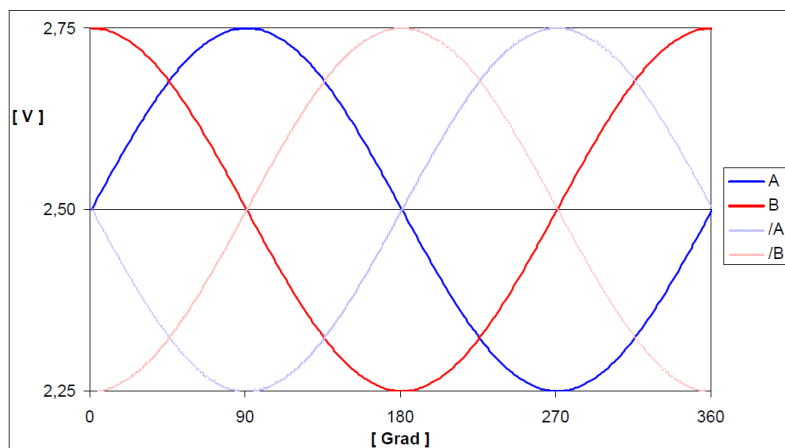

Figure 2: Example for signal waveform at sin/cos encoders

If "RJ45:Encoder" is selected during parameterization under point 1.3 (encoder selection), a defined failure behavior (high-impedance outputs) must be given in the event of faulty supply voltage or internal encoder errors.

Whether the encoder has a high-impedance failure behavior must be clarified with the manufacturer.

Due to the higher safety category (SIL3/PL e) of the speed monitor 3TK2810-1, the connected encoder is safety-related upgraded. This means that encoder errors (e.g. faulty phase shift, faulty pulse/pause ratio, wire breaks, defective output signals, interference oscillations, ...) are detected by the speed monitor 3TK2810-1. This allows the application to reach PL e according to EN ISO 13849 and SIL CL 3 according to IEC/EN 62061.

Encoders with synthetically generated output signals must not be used.

Use of encoders

Attention To achieve the highest possible SIL / PL when using encoders, 2-channel encoders (4 tracks: A, A/, B, B/) with defined failure behavior (high-impedance outputs > 170 kOhm) must be used. If this information is not available from the encoder manufacturer's data sheet, the manufacturer must be consulted about the behavior in the event of encoder failure.

Concussion of encoders

Attention Vibrations and shocks may interfere with the output signals of encoders and initiators. You must therefore ensure that valid input signals are always present on the 3TK2810-1 speed monitor under all influences.

If vibrations or shocks cannot be precluded, ensure that the design of the encoders being used does not allow for interference of its output signals.

When using initiators, ensure that signal change occurs on both channels simultaneously.

Non-observance of the abovementioned information may lead to error messages as a result of invalid signals.

2 Contact/ Support

Siemens AG	
Support Request	siemens.com/support-request
Technical Support	support.industry.siemens.com
Phone	+49 (911) 895-7222