

SIEMENS

SIMATIC

Industrial PC SIMATIC IPC1047

Operating Instructions

Preface

Overview

1

Safety Instructions

2

Installing and connecting the device

3

Commissioning the device

4

Operating the device

5

Expanding and assigning parameters to the device

6

Device maintenance and repair

7

Technical specifications

8

Dimension drawings

9

Standards and approvals

10

Technical support

A

Markings and symbols

B



Abbreviations

C

Legal information

Warning notice system

This manual contains notices you have to observe in order to ensure your personal safety, as well as to prevent damage to property. The notices referring to your personal safety are highlighted in the manual by a safety alert symbol, notices referring only to property damage have no safety alert symbol. These notices shown below are graded according to the degree of danger.

 DANGER
indicates that death or severe personal injury will result if proper precautions are not taken.
 WARNING
indicates that death or severe personal injury may result if proper precautions are not taken.
 CAUTION
indicates that minor personal injury can result if proper precautions are not taken.
NOTICE
indicates that property damage can result if proper precautions are not taken.

If more than one degree of danger is present, the warning notice representing the highest degree of danger will be used. A notice warning of injury to persons with a safety alert symbol may also include a warning relating to property damage.

Qualified Personnel

The product/system described in this documentation may be operated only by **personnel qualified** for the specific task in accordance with the relevant documentation, in particular its warning notices and safety instructions. Qualified personnel are those who, based on their training and experience, are capable of identifying risks and avoiding potential hazards when working with these products/systems.

Proper use of Siemens products

Note the following:

 WARNING
Siemens products may only be used for the applications described in the catalog and in the relevant technical documentation. If products and components from other manufacturers are used, these must be recommended or approved by Siemens. Proper transport, storage, installation, assembly, commissioning, operation and maintenance are required to ensure that the products operate safely and without any problems. The permissible ambient conditions must be complied with. The information in the relevant documentation must be observed.

Trademarks

All names identified by ® are registered trademarks of Siemens AG. The remaining trademarks in this publication may be trademarks whose use by third parties for their own purposes could violate the rights of the owner.

Disclaimer of Liability

We have reviewed the contents of this publication to ensure consistency with the hardware and software described. Since variance cannot be precluded entirely, we cannot guarantee full consistency. However, the information in this publication is reviewed regularly and any necessary corrections are included in subsequent editions.

Preface

These operating instructions contain all the information you need for commissioning and operation of the SIMATIC IPC1047.

It is intended both for programming and testing personnel who commission the device and connect it with other units (automation systems, programming devices), as well as for service and maintenance personnel who install add-ons or carry out fault/error analyses.

Basic knowledge required

A solid background in electrical installation, personal computers, Microsoft operating systems and network technology is required to understand this manual.

Validity of the Operating Instructions

These operating instructions are valid for all supplied versions of the SIMATIC IPC1047.

Scope of this documentation

The documentation for the SIMATIC IPC1047 includes:

- Product Information "Important notes on your device"
- Quick Install Guide
- Operating instructions in German, English and French

Refer to the corresponding user documentation for information and instructions on using software.

Conventions

The following naming conventions apply in these operating instructions:

- The terms "Industrial PC", "PC" or "device" are also used in place of the product name "SIMATIC IPC1047".
- The abbreviation "Microsoft Windows" or "Windows" is also used in place of the brand name Microsoft® Windows®.

History

Currently released versions of these operating instructions:

Version	Comments
09/2018	First edition
07/2019	New edition, description of configurable device features added, security provisions revised in accordance with IEC/EN/UL 61010-2-201

Security information

Siemens provides products and solutions with industrial security functions that support the secure operation of plants, systems, machines and networks.

In order to protect plants, systems, machines and networks against cyber threats, it is necessary to implement – and continuously maintain – a holistic, state-of-the-art industrial security concept. Siemens' products and solutions constitute one element of such a concept.

Customers are responsible for preventing unauthorized access to their plants, systems, machines and networks. Such systems, machines and components should only be connected to an enterprise network or the internet if and to the extent such a connection is necessary and only when appropriate security measures (e.g. firewalls and/or network segmentation) are in place.

For additional information on industrial security measures that may be implemented, please visit (<http://www.siemens.com/industrialsecurity>).

Siemens' products and solutions undergo continuous development to make them more secure. Siemens strongly recommends that product updates are applied as soon as they are available and that the latest product versions are used. Use of product versions that are no longer supported, and failure to apply the latest updates may increase customers' exposure to cyber threats.

To stay informed about product updates, subscribe to the Siemens Industrial Security RSS Feed visit (<http://www.siemens.com/industrialsecurity>).

Disclaimer for third-party software updates

This product includes third-party software. Siemens AG only provides a warranty for updates/patches of the third-party software, if these have been distributed as part of a Siemens software update service contract or officially released by Siemens AG. Otherwise, updates/patches are undertaken at your own risk. You can find more information about our Software Update Service offer on the Internet at Software Update Service (<http://www.automation.siemens.com/mcms/automation-software/en/software-update-service>).

NOTICE
Danger for machine and plant through unauthorized remote access
IPMI remote monitoring has a known standard password in the delivery state. This allows unauthorized access to the device from the outside by third parties. Damage to the machine or plant is not excluded.
<ul style="list-style-type: none">• Change the IPMI password immediately after commissioning the device. You can find additional information in the sections "Monitoring functions (Page 51)" and "IPMI Setup (Page 99)".• Alternatively, do not connect IPMI-enabled devices to the Internet or any network at all.

Table of contents

	Preface	3
1	Overview.....	9
1.1	Product description	9
1.1.1	Overview	9
1.1.2	Scope of application.....	9
1.1.3	Highlights	10
1.1.4	Features	11
1.2	Design of the device	13
1.2.1	Front panel.....	13
1.2.2	Rear of the device.....	14
1.2.3	Interfaces at rear of the device	15
1.2.4	Status displays	16
1.2.4.1	System status displays	16
1.2.4.2	Power indicators, redundant power supply.....	17
1.2.4.3	Status displays on removable tray for drives	19
1.3	Accessories and spare parts	20
2	Safety Instructions	21
2.1	General safety instructions	21
2.2	Notes on ambient and environmental conditions.....	26
3	Installing and connecting the device	29
3.1	Preparing for installation	29
3.1.1	Checking the delivery package.....	29
3.1.2	Identification data of the device	29
3.1.3	Permitted mounting positions	30
3.2	Mounting the device.....	31
3.2.1	Installation guidelines.....	31
3.2.2	Mounting the device.....	32
3.3	Connecting the device	33
3.3.1	Country-specific information on supply voltage	33
3.3.2	Connecting the power supply	34
3.3.2.1	Information about the power supply.....	34
3.3.2.2	Connecting a single power supply	34
3.3.2.3	Connecting a redundant power supply	35
3.3.3	Connecting I/O devices.....	36
4	Commissioning the device	37
4.1	General information on commissioning	37
4.2	Switching on the device	38
4.3	Automatic switching on of the device.....	39
4.4	Switching off the device	39

5	Operating the device	41
5.1	Opening the front door	41
5.2	Drive configurations	41
5.2.1	Multi-disk system.....	41
5.2.2	RAID systems	42
5.2.2.1	Manage RAID system	42
5.2.2.2	RAID system of the motherboard.....	43
5.2.2.3	SAS/SATA hardware RAID system	43
5.2.2.4	RAID1 system	45
5.3	Operating RAID systems	46
5.3.1	Manage onboard RAID system.....	46
5.3.1.1	Example for a RAID1 system during the boot phase of the system	46
5.3.1.2	RAID software	47
5.3.1.3	Checking the status of the RAID system	47
5.3.1.4	Displaying a defective hard disk of a RAID system in the RAID software	48
5.3.1.5	Special feature: Replacing hard disk in the RAID system when switched off	48
5.3.1.6	Integrating a new hard disk drive in the RAID system	49
5.3.2	Managing the Hardware RAID system	50
5.4	Monitoring functions	51
5.5	Trusted Platform Module (TPM).....	52
6	Expanding and assigning parameters to the device	53
6.1	Open the device.	53
6.2	Drives	54
6.2.1	Overview	54
6.2.2	Drives in drive cage type A	56
6.2.2.1	Change 2.5" and 3.5" drive in removable tray	56
6.2.2.2	Installing a 5.25" adapter module for removable trays	58
6.2.2.3	Installing a backplane for removable tray	59
6.2.2.4	Changing a backplane for removable tray	61
6.2.3	Drives in drive cage type B	63
6.2.3.1	Overview	63
6.2.3.2	Removing and installing a tray from/in the drive cage	65
6.2.3.3	Removing and installing 3.5" drives from/in tray	66
6.2.3.4	Removing and installing 2.5" drives from/in tray	67
6.2.4	Replacing a defective hard disk drive in the RAID system	70
6.3	Expansion cards.....	71
6.3.1	Notes on the expansion cards	71
6.3.2	Configuration variants	72
6.3.3	Installing and removing expansion cards.....	73
6.3.4	Installing the PCI expansion kit (optional).....	74
6.3.5	Removing and installing the graphics card	76
6.3.6	Installing and configuring the hardware RAID adapter card	78
6.4	Installing a second COM interface (optional).....	80

7	Device maintenance and repair	81
7.1	Repair information	81
7.2	Maintenance intervals	82
7.3	Removing and installing hardware	82
7.3.1	Remove the fan cover	82
7.3.2	Replacing filters	83
7.3.3	Replacing device fans	83
7.3.4	Change the fan on drive cage type A	85
7.3.5	Replacing the backup battery	87
7.3.6	Replacing the redundant power supply module	89
7.3.7	Replacing the processor	90
7.4	Installing the software	91
7.4.1	Back-up authorization or license key	91
7.4.2	Restoring the factory settings of the operating system and partitions (Restore)	92
7.4.3	Updating the operating system	93
7.4.4	Installing drivers and software	94
7.4.5	Installing Windows (Recovery)	94
7.4.6	Installing Hardware RAID controller software	98
7.5	BIOS description	99
7.6	IPMI Setup	99
7.7	Recycling and disposal	100
8	Technical specifications	101
8.1	General specifications	101
8.2	Current and power requirements	105
8.3	Power supply (AC)	106
8.4	AC power supply, redundant	107
8.5	Motherboard	108
9	Dimension drawings	109
9.1	Dimensional drawing of the device	109
9.2	Dimension drawing for telescope rails	110
9.3	Dimension drawing of the expansion cards	110
10	Standards and approvals	111
A	Technical support	113
A.1	Service and support	113
A.2	Troubleshooting	114
A.2.1	Problems with device functions	114
A.2.2	Problems with the RAID system and device startup	115
A.2.3	Problems when using expansion cards	116

B	Markings and symbols	117
	B.1 Overview	117
	B.2 Safety	117
	B.3 Operator controls	118
	B.4 Certificates, approvals and markings.....	117
	B.5 Interfaces	118
C	Abbreviations.....	119
	Glossary	125
	Index	133

Overview

1.1 Product description

1.1.1 Overview

The SIMATIC IPC1047 is a high-performance rack PC with industrial functionality:

- Highly compact
- Extremely rugged
- Extensive product continuity



Note

Depending on the configuration ordered, the features and illustrations described in this manual may differ from the features of your device.

1.1.2 Scope of application

The device offers very high computing power in a compact enclosure for 19" rack installation. It has a high degree of flexible expandability for diverse performance-driven applications:

- Scientific calculations and simulations
- Image processing and editing
- Cryptography
- Process monitoring
- Virtualization
- Quality assurance
- Scada applications
- Artificial intelligence, machine learning

1.1.3 Highlights

Performance optimized to the application

- High computing and graphics performance
- Use of suitable drives and memory

High level of functionality and ease of service

- High availability through redundancy and optimized cooling
- Rack design for easy installation

Use in a rugged environment

- Extended temperature range
- Dust exposure, shock and vibration

High investment protection

- High continuity of the components/design
- Product availability up to 5 years
- Repair service for additional 5 years

High system availability

- ECC memory modules
- Redundant power supply (optional)
- Integration of redundant or high-performance SAS/SATA/RAID data systems with additional controller card (optional)
- Hardware RAID
 - Auto-Rebuild for change of hard disk
 - "Zero-Maintenance Cache Protection" protects the data in the hardware RAID controller cache in the event of a power failure
 - Reduced load on the main processor during the rebuild
 - Fast HDDs/SSDs for high speed when reading and writing data

1.1.4 Features

General features	
Design	<ul style="list-style-type: none"> • 19" rack, 4 HU, 572 mm enclosure depth • Rugged bay enclosure • Prepared for mounting telescopic rails • Can be mounted horizontally • Lockable enclosure front
Motherboard	Dual socket R3 (LGA 2011-3) supports Intel® Xeon® processor E5-v3/v4 generation
CPU	Dual Intel® Xeon® E5-26xx series, from 1.7 GHz/8 cores to 2.3 GHz/14 cores
Main memory configuration	Up to 512 GB DDR4 RAM 2400 MHz (more memory available as an option on request)
Hard disk space	Up to 16 TB
Drive bays	Up to 4 × 3.5" or 8 × 2.5" drive in internal drive cage or in removable drive bay
Expansion card slots	<ul style="list-style-type: none"> • 3 × PCIe x8 • 3 × PCIe x16
Power supply	<ul style="list-style-type: none"> • Single power supply 100 ... 240 V AC (-10%; +10%), wide-range 13–7 A, 47–63 Hz, 860 watts or • Redundant power supply 2 × 100 ... 240 V AC (-10%; +10%), wide-range 10–5 A, 60–50 Hz, 700 watts
Interfaces	
Ethernet	<ul style="list-style-type: none"> • 2 × 1 Gbps (INTEL I350) • 1 × RJ45 IPMI LAN See section "Monitoring functions (Page 51)"
USB	<ul style="list-style-type: none"> • 2 × USB 3.0 (front) • 2 × USB 3.0 (rear) • 2 × USB 2.0 (rear)
Serial	<ul style="list-style-type: none"> • 1 × COM port (rear) • 1 × COM port (rear, optional)
Monitor	1 × VGA, optional Nvidia Quadro Px expansion card
TPM	1 × TPM 1.2 20-pin header
Monitoring functions	
Voltages	Voltage monitoring for motherboard, CPU, memory
Temperatures	Temperature monitoring of CPU, memory, HDD, mainboard with corresponding closed-loop control of fan speeds
LED	<ul style="list-style-type: none"> • POWER (internal power supply present, PC switched on) • HDD (access to hard disk) • FAN FAIL (display fan problems)
Power supply status, power, temperatures, voltages	Monitoring of redundant power supply (optional)

1.1 Product description

Operating systems	
Operating system for order, pre-installed	Microsoft® Windows® 10 Enterprise 2016 LTSC, 64-bit, multi-language ¹
Operating system for order, license and drivers, not pre-installed	Microsoft® Windows® Server 2016 Standard Edition incl. 5 Clients, 64-bit, multi-language ¹ (additional licenses possible as an option on request)
Alternative: without operating system	Compatibility with the motherboard

¹ Multi-language user interface MUI: 5 languages (English, German, French, Spanish, Italian)

Optional accessories	
DOM	2 × SuperDOM (Disk on Module)
PCI expansion card	Can be mounted crosswise as complete PCI expansion kit
PCI graphics card	<ul style="list-style-type: none"> • NVIDIA Quadro P400, 64-bit, 2 GB GDDR5 RAM, 4 × Mini DisplayPort, resolution: 3 × 4096×2160 @ 60 Hz, 1 × 5120×2880 @ 60 Hz • NVIDIA Quadro P1000, 128-bit, 4 GB GDDR5 RAM, 4 × Mini DisplayPort, resolution: 4 × 4096×2160 @ 60 Hz, 4 × 5120×2880 @ 60 Hz • NVIDIA Quadro P4000, 256-bit, 8 GB GDDR5 RAM, 4 × DisplayPort, resolution: 4 × 4096×2160 @ 120 Hz, 4 × 5120×2880 @ 60 Hz • NVIDIA Quadro P5000, 256-bit, 16 GB GDDR5X RAM, 4 × DisplayPort, resolution: 4 × 7680×4320 @ 30 Hz, 4 × 2560×1600 @ 60 Hz
PCI hardware RAID controller	<ul style="list-style-type: none"> • Adaptec RAID 8405 PCIe 3.0 x8 with: <ul style="list-style-type: none"> – 4 SAS/SATA ports – CPU and cache memory, therefore negligible effect on the system – Backup for data reliability in the event of power failures • Adaptec RAID 8805 PCIe 3.0 x8 with: <ul style="list-style-type: none"> – 8 SAS/SATA ports – CPU and cache memory, therefore negligible effect on the system – Backup for data reliability in the event of power failures
LAN expansion card	<ul style="list-style-type: none"> • Intel® I350-T2, 2 × 1 GB LAN • Intel® I350-T4, 4 × 1 GB LAN • Intel® X540-T2, 2 × 10 GB LAN

1.2 Design of the device

1.2.1 Front panel

Front view



- ① 19" mounting bracket
- ② Fan cover on front fan with ventilation openings, locked by front door
- ③ System status displays (Page 16)
- ④ Front door: lockable, protection against unauthorized access
- ⑤ Lock
 - Key vertical: open
 - Key horizontal: closed

View with front door open

The following figures show examples of devices with front door open. Depending on the configuration, the device is equipped with one of the following drive cages:

- **Drive cage type A** with slots for removable drives
The removable trays can be locked; this way, the drives are protected from unauthorized access.
- **Drive cage type B** with fixed slots for drives

1.2 Design of the device

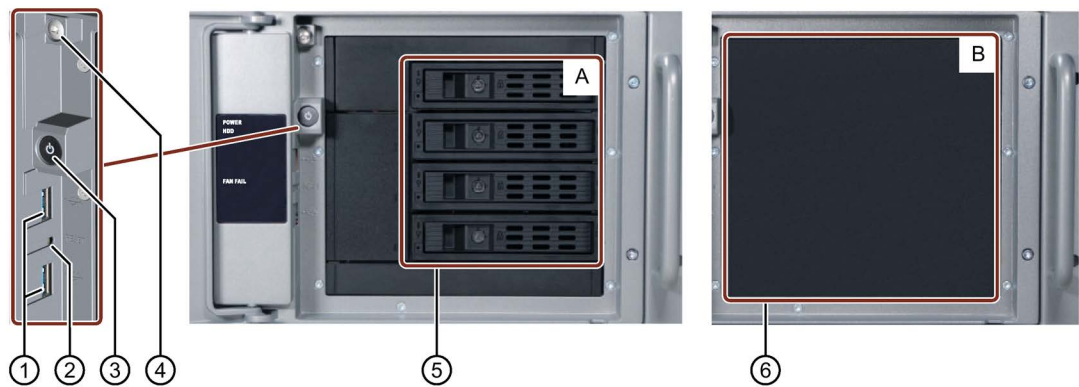

- ① USB 3.0 ports
- ② Reset button
- ③ On/off button
- ④ Captive locking screw of the enclosure cover
- ⑤ Slots for removable drives in drive cage type A
- ⑥ Slot covers for drives in drive cage type B

1.2.2 Rear of the device

Rear view with AC power supply

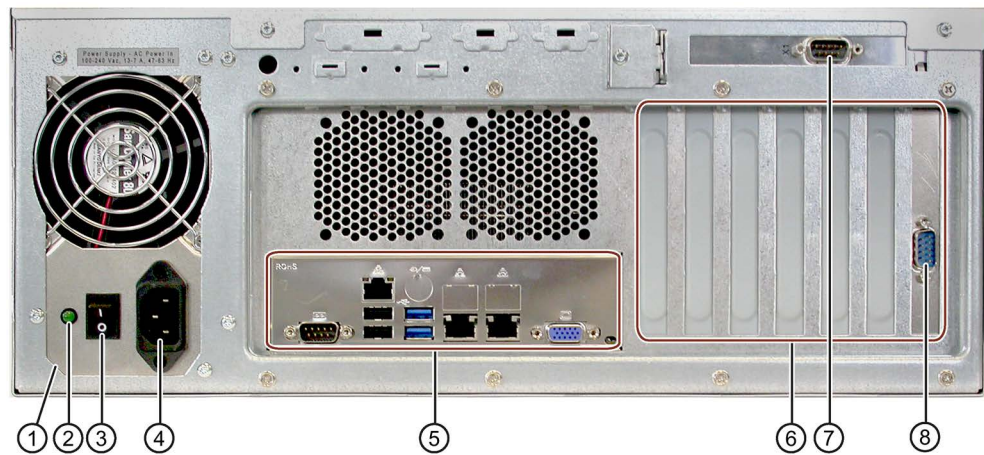

- ① ATX power supply
- ② Power LED
- ③ On/off switch
- ④ Power connection socket
- ⑤ Interfaces
- ⑥ Expansion card slots
- ⑦ PCI expansion kit interface (optional)
- ⑧ 2nd COM interface (optional)

Rear view with redundant AC power supply

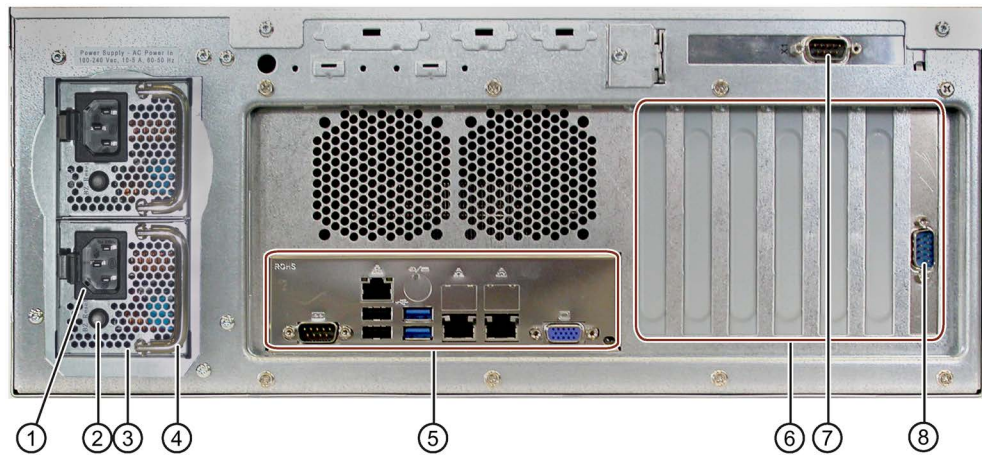

- ① Power connection socket
- ② Acknowledgment button with status LED
- ③ Power supply module
- ④ Handle
- ⑤ Interfaces
- ⑥ Expansion card slots
- ⑦ PCI expansion kit interface (optional)
- ⑧ 2nd COM interface (optional)

1.2.3 Interfaces at rear of the device

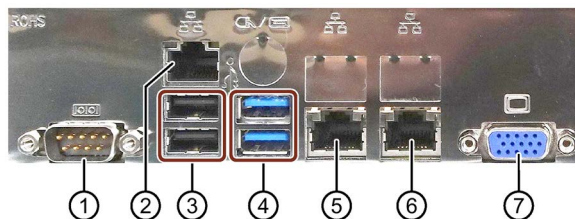

- ① COM interface
- ② RJ45 IPMI dedicated LAN connection
- ③ USB 2.0 ports
- ④ USB 3.0 ports
- ⑤ Gbit ETHERNET interface 1
- ⑥ Gbit ETHERNET interface 2
- ⑦ VGA connection

1.2.4 Status displays

1.2.4.1 System status displays

Front status displays

The status displays provide information on the status of the device components listed in the following table. The operating indicators are visible when the front door is closed and open.

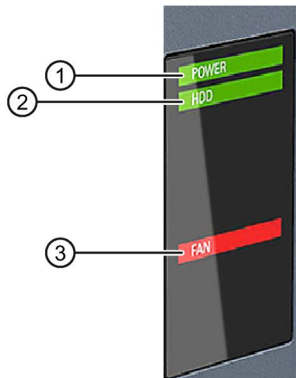

- ① "POWER" LED
- ② "HDD" LED
- ③ "FAN FAIL" LED

Meaning of the LEDs

LED	Meaning	LED status	Meaning of the status
POWER	Operating mode of the PC	OFF	Switched off or disconnected from the mains
		YELLOW	Idle state or shut down
		GREEN	PC in operation
HDD	Access to hard disk	OFF	No access
		GREEN	Access
FAN FAIL	Fan status	OFF	No error
		RED flashing	Possible causes: <ul style="list-style-type: none"> • CPU heat sink fan fault • Front fan faulty • Power supply fan fault

Rear status displays

The Ethernet interfaces with the following status displays are located on the rear of the device:

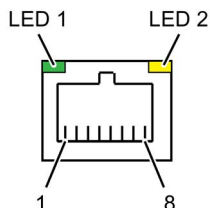

LED	Meaning	LED status	Meaning of the status
LED 1 ¹	Connection status	OFF	<ul style="list-style-type: none"> No cable connected Cable disabled Interface disabled
		GREEN	<ul style="list-style-type: none"> Active cable connected
		GREEN, flashing	<ul style="list-style-type: none"> Data transfer active
LED 2 ¹	Data transmission rate	OFF	<ul style="list-style-type: none"> 10 Mbps
		GREEN	<ul style="list-style-type: none"> 100 Mbps
		YELLOW	<ul style="list-style-type: none"> 1000 Mbps

¹ The Ethernet ports are numbered on the enclosure to identify them clearly. The numbering by the operating system may deviate from this.

1.2.4.2 Power indicators, redundant power supply

Rear

The power supply unit of the redundant power supply consists of two power supply modules. The power supply unit works as soon as one power supply module is in operation. If a power supply module is out of service, a visual and audible warning signal sounds.

The following figure shows an example with power supply module ① in operation and power supply module ② out of service.

1.2 Design of the device

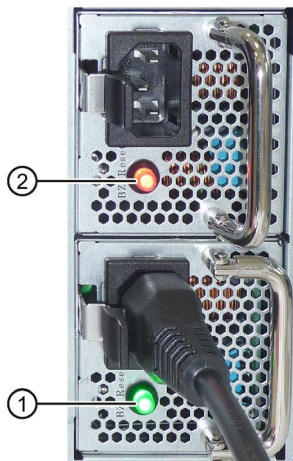

LED	Meaning	LED status	Meaning of the status
LED of acknowledgment button 1	Operating status of power supply module 1	OFF	Device disconnected from power supply
		Flashes GREEN	<ul style="list-style-type: none"> Power supply module 1 ready for operation PC switched off
		GREEN	<ul style="list-style-type: none"> Power supply module 1 in operation PC switched on
		Flashes RED	Power supply 1 interrupted
		RED	Power supply module 1 defective
		Flashes slowly RED/GREEN	Warning at power supply module 1, e.g. overload
LED of acknowledgment button 2	Operating status of power supply module 2	OFF	Device disconnected from power supply
		Flashes GREEN	<ul style="list-style-type: none"> Power supply module 2 ready for operation PC switched off
		GREEN	<ul style="list-style-type: none"> Power supply module 2 in operation PC switched on
		Flashes RED	Power supply 2 interrupted
		RED	Power supply module 2 defective
		Flashes slowly RED/GREEN	Warning at power supply module 2, e.g. overload

1.2.4.3 Status displays on removable tray for drives

The following figure shows the status displays of a removable tray in devices with drive cage type A.



- ① "Power" LED
- ② "Activity" LED

Meaning of the LEDs

LED	Meaning	LED status	Meaning of the status
Power	Status of the removable tray	OFF	<ul style="list-style-type: none"> • Device switched off • Power supply not connected • No drive installed
		Lit	<ul style="list-style-type: none"> • Device is switched on and a drive is installed
Activity	Status of the drive	Flashes	<ul style="list-style-type: none"> • Drive is active
		OFF	<ul style="list-style-type: none"> • Drive is not active

1.3 Accessories and spare parts

Accessories from Siemens are available for your device. These are not included in the scope of delivery.

Obtaining accessories from the SIEMENS Industry Mall

You can find additional information in the online ordering system Industry Mall (<https://mall.industry.siemens.com>).

Accessories available for order

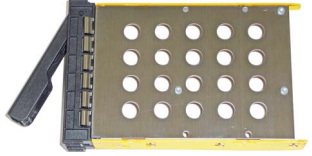
Name	Description	Article number
Low profile removable rack unit	<p>The removable tray makes for quick and simple replacement of a 2.5" or 3.5" drive without having to open the device or remove it from the control cabinet. The result is the following advantages for service and maintenance, data backup and data transfer:</p> <ul style="list-style-type: none"> • Replacement of a failed hard disk in operation ("hot-swap") • Downloading different system states or operating systems from different hard drives during a short period of time. • Simplified data backup by copying, for example, to a backup hard drive. • Simple transportation of backup data • Separate data storage and archiving possible 	<p>6ES7648-0EH00-1BA0</p> 
PCI expansion kit	Riser card with slot for PCI expansion card	6BK1700-6HA70-0AA0
Filter pad	Filter pad for fan cover on the device front, package with 10 filter pads	A5E37019277
Device fan	Internal fan	6BK1700-6HA71-0AA0
Backup battery	The battery is used to back up the CMOS data for the BIOS setup and the real-time clock.	6BK1700-6HA73-0AA0
Restore USB stick Windows 10	USB stick for restoring the delivery state of the operating system, drivers and partitioning	A5E47323540
USB stick Windows Server 2016	USB stick for restoring the operating system	A5E47932416

SIEMENS spare parts services

Information on ordering, the provision and delivery of spare parts can be found under "Industry Online Support: Spare parts services (<http://support.automation.siemens.com/WW/view/en/16611927>)".

Safety Instructions

2.1 General safety instructions

 WARNING
<p>The installer of the system is responsible for the safety of a system in which the device is integrated.</p> <p>There is a risk of malfunction which could result in death or serious injury.</p> <ul style="list-style-type: none">• Ensure that only suitably qualified personnel perform the work.

Risk of physical injury

 CAUTION
<p>Risk of physical injury</p> <p>The device is heavy, may fall down, injure persons and be damaged.</p> <ul style="list-style-type: none">• Use the handles on the front panel to carry and lift the device.

Risk due to electric shock

 WARNING
<p>Risk of electric shock</p> <p>The on/off button and on/off switch do not fully disconnect the device from the line voltage.</p> <p>There is also a risk of fire if the device or connecting lines are damaged.</p> <ul style="list-style-type: none">• Always fully disconnect the device from the mains voltage before performing work on the device or when the device will not be used over an extended period of time.• For control cabinet installation: Use a central, easily accessible AC circuit breaker close to the device, if possible.

Risk of lightning strikes

 DANGER
Risk of lightning strikes
A lightning flash may enter the mains cables and data transmission cables and jump to a person.
Death, serious injury and burns may result.
<ul style="list-style-type: none">• Disconnect the device from the power supply in good time when a thunderstorm is approaching.• Do not touch power cables and data transmission cables during a thunderstorm.• Keep a sufficient distance from electrical cables, distributors, systems, etc.

Avoiding functional restrictions

NOTICE
Possible functional restrictions in case of non-validated plant operation
The device is tested and certified on the basis of the technical standards. In rare cases, functional restrictions can occur during plant operation.
Validate the correct functioning of the plant to avoid functional restrictions.

Use in industrial environments

Note

Use in an industrial environment without additional protective measures

This device was designed for use in a normal industrial environment according to IEC 60721-3-3.

ESD directive



Electrostatic sensitive devices can be labeled with an appropriate symbol.

NOTICE
Electrostatic sensitive devices (ESD)
The device contains electronic components that may be destroyed by electrostatic charges. This can result in malfunctions and damage to the machine or plant.
Take corresponding precautionary measures when you open the device.

Access protection

 CAUTION
<p>Protection against access by unauthorized persons</p> <p>An unauthorized user can operate the device incorrectly and bypass logon by restarting the device.</p> <p>Operator actions by unauthorized persons jeopardize operational reliability.</p> <p>Take the following safety precautions:</p> <ul style="list-style-type: none">• Close the front door and, if installed, the removable drive bay.• Do not use keyboards with an on/off button (Power button).• If the device has a on/off button, assign the parameters of the function of the on/off button to meet your requirements under Windows. You can find the settings in the "Power Options" menu.

Headphones

 CAUTION
<p>Impaired hearing due to excessive sound pressure</p> <p>The setting of the volume and the equalizer can increase the sound pressure in the headphones. Other factors not mentioned by the manufacturer can also influence the sound pressure, for example, the operating system, equalizer software, firmware and driver.</p> <p>Excessive sound pressure from headphones can result in impaired hearing or even loss of hearing.</p> <p>Set the volume control and equalizer to the lowest value before you put on the headphones. Keep checking the volume control setting. Only use headphones and software approved by the manufacturer.</p>

Damage caused by transportation and storage

NOTICE
<p>Damage to the device during transport and storage</p> <p>If a device is transported or stored without packaging, shocks, vibrations, pressure and moisture may impact the unprotected unit. Damaged packaging indicates that ambient conditions have already had a massive impact on the device and it may be damaged.</p> <p>This may cause the device, machine or plant to malfunction.</p> <ul style="list-style-type: none">• Keep the original packaging.• Pack the device in the original packaging for transportation and storage.

 **WARNING**

Electric shock and fire hazard due to damaged device

A damaged device can be under hazardous voltage and trigger a fire in the machine or plant. A damaged device has unpredictable properties and states.

Death or serious injury could occur.

- Avoid installing and commissioning a damaged device.
- Label the damaged device and keep it locked away. Send off the device for immediate repair.

Damage from condensation

NOTICE

Damage from condensation

If the device is subjected to low temperatures or extreme fluctuations in temperature during transportation, moisture could occur on or inside the HMI device (condensation).

Moisture can cause a short-circuit in electrical circuits and damage the device.

- Store the device in a dry place.
- Bring the device to room temperature before starting it up.
- Do not expose the device to direct heat radiation from a heating device.
- If condensation develops, wait approximately 12 hours or until the device is completely dry before switching it on.

Fire protection enclosure

Note

The device meets the requirements for fire protection enclosures in accordance with IEC/EN/UL 61010-2-201. It can therefore be installed without an additional fire protection cover.

Rack mounting

Note

Rack-mount instructions

- **Elevated operating temperature**
If installed in a closed or multi-unit rack, the operating ambient temperature may be greater than the room temperature. Install the device in an environment recommended by the manufacturer.
- **Reduced air flow**
When installing the device in a rack, ensure that the air flow required for safe operation of the device is guaranteed.
- **Mechanical load**
Mounting of the equipment in the rack should be such that a hazardous condition is not caused due to an uneven mechanical load.
- **Circuit overload**
When connecting the devices to the power supply, observe the rated values specified on the nameplate of the devices.
- **Reliable grounding**
Reliable grounding of rack-mounted equipment should be ensured.

Device in the control cabinet

DANGER

Life-threatening voltages when control cabinet is open

When you open the control cabinet, there may be dangerous voltages at certain areas or components possibly caused by other devices.

Touching these areas or components can cause death or serious physical injury.

- Always disconnect the cabinet from the mains before opening it.
- Ensure that the power to the control cabinet cannot be turned on accidentally.

2.2 Notes on ambient and environmental conditions

Approvals

 WARNING
Voided approvals If the following conditions are not met when installing the system, the UL 61010-2-201, EN 61010-2-201 approvals are voided and there is a risk of overheating and personal injury. You should observe the following information on ambient and environmental conditions.

Ambient and environmental conditions

NOTICE
Ambient conditions and chemical resistance Unsuitable environmental conditions can cause faults or damage the device. Failure to comply nullifies the warranty in accordance with IEC/EN/UL 61010-2-201. <ul style="list-style-type: none">• Operate the device only in closed rooms.• Only operate the device in the ambient conditions specified in the technical specifications.• Observe the permitted mounting positions of the device.• Do not obstruct the venting slots of the device.• When the device is operated in severe environments which are subject to caustic vapors or gases, ensure sufficient clean air is provided.• Clean the enclosure surface with a damp cloth and make sure that no water enters the device.

When you plan your project, you should make allowances for:

- The climatic and mechanical environmental conditions specified in the operating instructions.
- Do not operate the device in severe environments which are subject to caustic vapors or gases.
- Avoid extreme ambient conditions such as heat.
- Do not expose the device to direct sunlight or other powerful light sources.
- Install the device in such a way that it poses no danger.
- Always maintain a minimum clearance of 50 mm to the area of the ventilation slots and do not cover the ventilation slots of the enclosure.
- Ensure that there is a distance of at least 50 cm at the back of the device, depending on wiring.
- You can install the device without an additional fire protection enclosure. It meets the requirements for fire protection enclosures in accordance with IEC/EN/UL 61010-2-201.
- Ensure that the installation opening for the device is splash-proof in areas which may be subject to splash water.

High frequency radiation

 CAUTION
Immunity to RF interference <p>The device has an increased immunity to RF radiation according to the specifications on electromagnetic compatibility in the technical specifications.</p> <p>High frequency radiation above the specified immunity limits can result in malfunctioning of the device.</p> <p>Persons are injured and the plant is damaged.</p> <ul style="list-style-type: none">• Avoid high-frequency radiation.• Remove radiation sources from the environment of the device.• Switch off radiating devices.• Reduce the radio output of radiating devices.• Read the information on electromagnetic compatibility.• Read the information in the technical specifications.

I/O devices

 CAUTION
Fault caused by I/O devices <p>The connection of I/O devices can cause faults in the device.</p> <p>The result may be personal injury and damage to the machine or plant.</p> <ul style="list-style-type: none">• Only connect I/O devices which are approved for industrial applications in accordance with EN 61000-6-2 and IEC 61000-6-2.• I/O devices that are not hotplug-capable may only be connected after the device has been disconnected from the power supply.

NOTICE
Damage through regenerative feedback <p>Regenerative feedback of voltage to ground by a connected or installed component can damage the device.</p> <p>Connected or built-in I/Os, for example, a USB drive, are not permitted to supply any voltage to the device.</p> <p>Regenerative feedback is generally not permitted.</p>

Note

When measuring the counter emf, remember the following:

- The IPC in question must be turned off and the power supply connector must be plugged in.
 - During the measurement, all cables from the plant to the IPC should be connected.
 - All other components in the plant must be active.
-

Device and system extensions

 **CAUTION**

Fire hazard due to overheating of the device

Expansion cards generate additional heat. The device can overheat or cause a fire.

- Observe the safety and installation instructions for the expansion cards.
- Observe the max. permissible power consumption values.

NOTICE

Damage caused by device and system extensions

Device and system expansions may contain faults and affect the entire device, machine or plant. They may also violate safety rules and regulations regarding radio interference suppression.

If you install or replace device or system expansions and damage your device, the warranty is voided.

- Always disconnect the power plug before you open the device.
- Only install device or system expansions designed for this device.
- Observe the information on "Electromagnetic compatibility" provided in the technical specifications.

Contact your technical support team or the point of sale to find out which device and system expansions are suitable for installation.

Limitation of liability

- All technical specifications and approvals for the device apply only if you use expansion components that have a valid CE marking.
- Observe the installation instructions for expansion components in the associated documentation.
- UL approval of the device only applies when the UL-approved components are used according to their "Conditions of Acceptability".
- We are not liable for functional limitations caused by the use of third-party devices or components.

Installing and connecting the device

3.1 Preparing for installation

3.1.1 Checking the delivery package

 WARNING
<p>Electric shock and fire hazard due to damaged device</p> <p>Damaged devices due to improper storage or transport may lead to personal injury and/or damage to equipment.</p> <p>Please make sure to observe the information in section "General safety instructions (Page 21)".</p>

Procedure

1. Check the packaging and package contents for visible transport damage.
If any transport damage is present at the time of delivery, lodge a complaint at the shipping company in charge. Have the shipper confirm the transport damage immediately.
2. Unpack the device at its installation location.
3. Keep the original packaging in case you have to transport the unit again.
4. Check the contents of the packaging and any accessories you may have ordered for completeness and damage.
Please inform the delivery service immediately if the package contents are incomplete or damaged or do not correspond with your order.
5. Please keep the documentation in a safe place. It is required for initial commissioning and is part of the device.
6. Make a note of the identification data of the device (Page 29).

3.1.2 Identification data of the device

The device can be clearly identified with the help of this identification data in case of repairs or theft.

Make note of identification data

Enter the following data in the table below:

Serial number	SVP...
Order no.	6BK...
Microsoft Windows Product Key	

3.1 Preparing for installation

The data can be found on the front of the device when the front door is open.

- Serial number (S): The serial number can be found on the nameplate. The following figure shows an example.

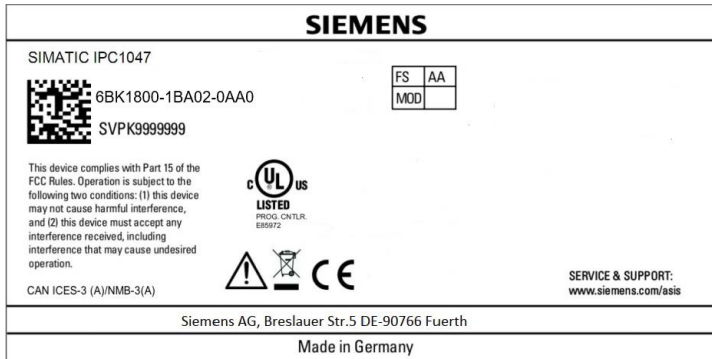

- Article number (1P) of the device
- Functional status (FS): A, B to H
- Microsoft Windows "Product Key" from the "Certificate of Authenticity" (COA label). You will need the Product Key if you reinstall the operating system. The following figure shows an example.



3.1.3 Permitted mounting positions

Optional installation locations

The device can be installed horizontally in consoles, control cabinets and 19" rack systems.

NOTICE
Operation in closed rooms
The device is approved for operation in closed rooms only. Pay attention to the ambient and environmental conditions.

3.2 Mounting the device

3.2.1 Installation guidelines

 WARNING
Dangerous voltage and fire hazard Improper actions during installation and assembly may lead to personal injury and/or damage to equipment. You should observe the installation and assembly notes under: <ul style="list-style-type: none">• General safety instructions (Page 21)• Notes on ambient and environmental conditions (Page 26) A high voltage may be present in the switchgear cabinet and could cause a dangerous electric shock. It may result in death or serious physical injury. Isolate the power supply to the switchgear cabinet before opening it. Ensure that the power to the control cabinet cannot be turned on accidentally.

 WARNING
Life-threatening voltages when control cabinet is open When you open the control cabinet, there may be a dangerous voltage at certain areas or components. Touching these areas or components can cause death or serious physical injury. <ul style="list-style-type: none">• Always disconnect the cabinet from the mains before opening it.• Ensure that the power to the control cabinet cannot be turned on accidentally.

 CAUTION
Risk of physical injury The device is too heavy to be mounted exclusively with the 19" brackets of the front panel. The device may fall down, injure people and get damaged. <ul style="list-style-type: none">• Secure the device additionally using cabinet brackets, telescopic rails or a device base. The mounting screws of the telescopic rails may not protrude more than 5 mm into the device.• Use the brackets on the front panel to carry and lift the unit.

3.2.2 Mounting the device

Mounting types

You can mount the device as follows:

- Mounting with cabinet brackets

The device can be installed horizontally in control cabinets and 19" rack systems.

This mounting type meets the requirements in accordance with IEC60297-3-100.

- Mounting on a device base

This mounting type meets the requirements in accordance with IEC60297-3-100.

- Mounting on telescopic rails

The device can be installed horizontally in control cabinets and 19" rack systems.

When telescopic rails are used for mounting, the device can be withdrawn fully from the cabinet or rack.

Position of the fastening hole holes for telescopic rails

The fastening holes for the telescopic rails of the various manufacturers are labeled in the following figure:

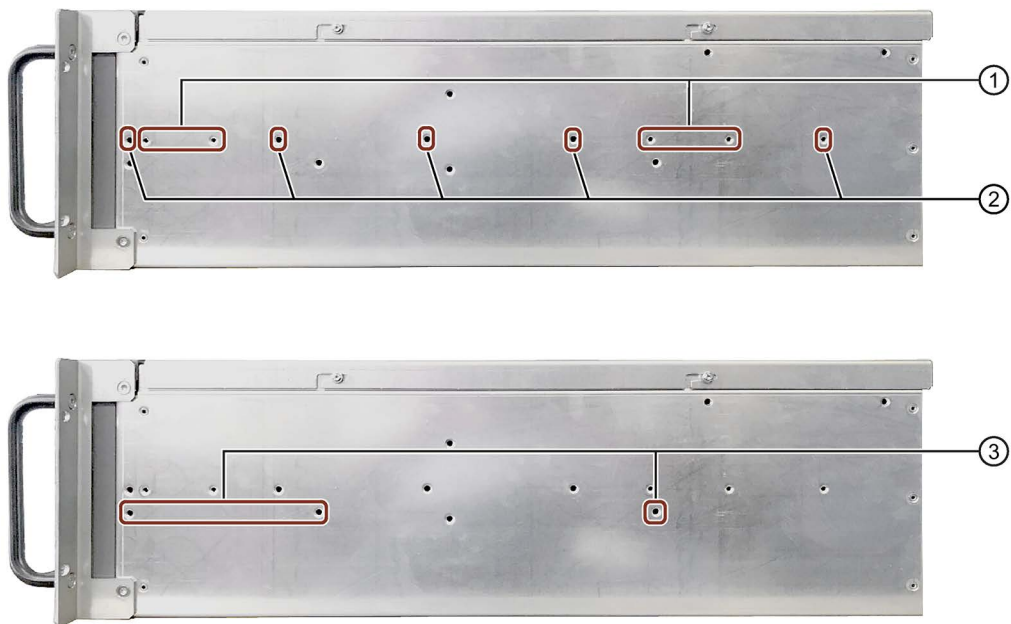

- ① Manufacturer Coolcase, article number 3001758
- ② Manufacturer Rittal, article number TS 3659.190 for 800 mm cabinets
- ③ Manufacturer Schroff, article number type 20110-072

The telescopic rails are secured with M4 screws. The dimensions for the associated mounting holes are listed in the section "Dimension drawing for telescope rails (Page 110)".

3.3 Connecting the device

3.3.1 Country-specific information on supply voltage

USA and Canada

Supply voltage 120 V / 230 V / 240 V

This device may only be connected to a grounded groundedSchuko socket outlet. Ensure that the power cords used are rated for the maximum current input and ambient temperature of the device and meet the requirements of the following standards:

- ANSI/UL 817
- CSA C22.2 No. 21

Ensure that the device connectors, connection sockets and connection materials are rated for the maximum current input and ambient temperature of the device and meet the requirements of the following standards:

- ANSI/UL 498 and CSA C22.2 No. 42
- CSA C22.2 No. 182.1
- CSA C22.2 No. 182.2
- CSA C22.2 No. 182.3

For countries other than the USA and Canada

Supply voltage 230 V AC

This device is supplied with a safety-tested power cord and may only be connected to a grounded SCHUKO socket outlet.

If you do not use the power cord, use a flexible cable that is rated for the maximum current input and ambient temperature of the device and complies with the safety regulations of the country in which the device is installed.

The power supply cord and the plug connector must bear the prescribed markings.

3.3.2 Connecting the power supply

3.3.2.1 Information about the power supply

 WARNING
Injury to persons or damage to property when operated on an incorrect power supply system
If you connect the device to an unsuitable power supply, the device receives voltages and currents that are too high or too low.
Injuries to persons, malfunctions or a damage to the device can result.
<ul style="list-style-type: none">• The permissible rated voltage of the device must match the local supply voltage.• Operate the device only in grounded power supply networks (TN networks in accordance with VDE 0100, Part 100 or IEC 60364-1).• Operation in non-grounded or impedance-grounded networks is not permitted.

 WARNING
Risk of electric shock
The on/off button and on/off switch do not fully disconnect the device from the line voltage.
There is also a risk of fire if the device or connecting lines are damaged.
<ul style="list-style-type: none">• Always fully disconnect the device from the mains voltage before performing work on the device or when the device will not be used over an extended period of time.• For control cabinet installation: Use a central, easily accessible AC circuit breaker close to the device, if possible.

3.3.2.2 Connecting a single power supply

Requirement

- 1 power supply cable
- You have observed the Information about the power supply (Page 34).
- The connecting cables, connectors, sockets and connection materials used meet the requirements according to section "Country-specific information on supply voltage (Page 33)".

Procedure

1. Set the on/off switch ① to position '0'.
This prevents the device from starting automatically when the power supply cable is plugged in.
 2. Connect the IEC connector of the power supply cable with the socket ②.
 3. Plug the power cable plug into the power outlet.
 4. Set the on/off switch ① to position 'I'.
- The power LED to the left of the on/off switch and on the front panel of the device lights up.

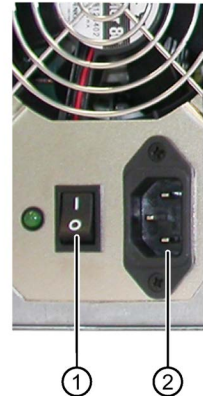
**3.3.2.3 Connecting a redundant power supply****Requirement**

- 2 power cables
- You have observed the Information about the power supply (Page 34).
- The connecting cables, connectors, sockets and connection materials used meet the requirements according to section "Country-specific information on supply voltage (Page 33)".

Procedure

1. Connect the IEC connector of a power supply cable with the socket ①. The LED of the acknowledgment button ② lights up green.
2. As soon as you connect the power plug, a warning signal sounds because only one power supply module is in operation. The LED of the acknowledgment button ④ flashes red.
Press the acknowledgment button ④. The warning signal stops.
3. Connect the IEC connector of the second power supply cable with the socket ③.
The LEDs of both acknowledgment buttons ② and ④ light up green.

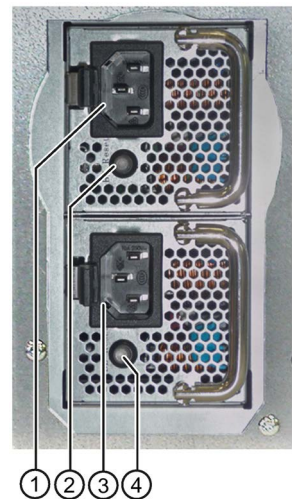
**Note**

If only one power supply module is switched on or connected, or a module is defective, a warning signal is emitted. The warning signal stops when the acknowledgment button is pressed.

3.3.3 Connecting I/O devices

 CAUTION
--

Fault caused by I/O devices

The improper connection of I/O devices can cause faults in the device.
--

The result may be personal injury and damage to the machine or plant.

Please make sure to observe the information relating to the connection of I/O devices in section "Notes on ambient and environmental conditions (Page 26)".

Procedure

Note

Use the original connections of the I/O to be connected without adapters or extensions.

1. Connect the I/O devices to the respective interfaces. Information on the position of the interfaces is available in "Interfaces at rear of the device (Page 15)".
2. Secure the cables with strain relief, if necessary.

Commissioning the device

4.1 General information on commissioning

Note**Switching the device on**

Depending on the version, the device has a single or double (redundant) power supply.

Single power supply:

- There is an **on/off switch** as a power switch on the back of the device.
- On/Off switch in position "1" (on): The device can be switched on using the on/off button on the front panel.
- On/Off switch in position "0" (off): The device consumes the least power from the AC mains.

The device cannot be switched on with the on/off switch in this case.

Redundant power supply:

- If one power supply module is defective, the device continues to run with the other power supply module.
 - After interruption and resumption of the entire power supply, the device restarts automatically.
 - If the operating system has been shut down, the device can be switched on using the on/off switch on the front panel.
-

Requirements for commissioning

The following requirements have to be met before you can start commissioning:

- I/O devices, keyboard, mouse and monitor are connected.
- The power supply is connected.
- An operating system is installed.

The device can be supplied without an operating system. You can find additional information on installation of the operating system in the section "Installing the software (Page 91)".

4.2 Switching on the device

NOTICE

Do not turn off the device during startup, do not change BIOS values

If you change the default values in the BIOS setup or if you turn off the device during installation, you disrupt the installation and the operating system is not installed correctly. The operating safety of the device and the plant is at risk.

Do not switch off the device during the entire installation process. Do not change the default values in the BIOS setup.

Procedure

Note

The following steps are only to be performed for initial startup of the device with factory settings.

1. Device with single power supply: Set the on/off switch to the "1" position. Information on the position of the switch is available in the section "Front panel (Page 13)".

A device with redundant power supply does not have an on/off switch.

2. Only when device is in standby: Briefly press the on/off switch on the front panel.
3. Wait until the following message disappears.

The green "POWER" LED lights up. The module carries out a self-test. During the self-test, the following message appears:

```
Press <Delete> to go to the main BIOS menu
```

When the message disappears, Windows starts on devices with a pre-installed operating system.

4. Follow the instructions on the screen.
5. Type in the product key as required.

The product key is located on the "Certificate of Authenticity" in the "Product Key" line, see section "Identification data of the device (Page 29)".

Result

The interface of the operating system is displayed every time you turn on the device and after the startup routine.

4.3 Automatic switching on of the device

In the BIOS setup, you can specify the behavior of the device when it is disconnected from the line voltage. The following property is set as default:

- BIOS setup, "Advanced" menu, "Power Configuration" submenu, setup parameter "Restore on AC Power Loss" to "Power On".
- After a power loss during operation, the device will automatically restart when the power returns.
- If the device was not in operation, it remains switched off when the power returns.

The line voltage must have failed for at least 20 s for the power failure to be detected and for this defined action to be executed.

NOTICE

Unintentional reactions at power loss restart

Automatic startup, for example, after a power failure, can result in unintentional reactions of the machine or plant. This endangers the operation.

Take the BIOS setup entry "Restore on AC Power Loss" into consideration in the plant planning.

4.4 Switching off the device

Shutting down the operating system

For Windows operating systems:

1. Press the key combination <Ctrl+Alt+Del>.
 2. Select "Shutdown".
- As an alternative to 1-3, briefly press the on/off button, unless this function is otherwise configured in the power options. For information on the position of the button, see section "Front panel (Page 13)".

For non-Windows operating systems:

- Briefly press the on/off button.

The operating system is shut down. The "POWER" LED goes out. The device is switched off but not fully disconnected from the line voltage.

Fully disconnecting the device from the line voltage

 WARNING
Risk of fire and electric shock The on/off button and on/off switch do not fully disconnect the device from the line voltage. If the device is switched off with the on/off switch, the electric shock hazard and fire hazard remain, for example, if the device or connection cables are damaged or if the device is used improperly. Always fully disconnect the device from the line voltage, as described below, before performing work on the device or when the device will not be used over an extended period of time.

If the device was not installed in a control cabinet:

- Shut down the operating system and unplug the power plug from the rear of the device.

If the device was installed in a control cabinet:

- Shut down the operating system and switch the AC circuit breaker to "Off".

The device is switched off and fully disconnected from the line voltage. No trickle current is flowing.

Hardware reset

You can perform a hardware reset to switch off the device when the operating system no longer responds to input from the keyboard or mouse. The operating system is not safely shut down in this case.

NOTICE
Risk of data loss The device is restarted in the case of a hardware reset. Data in the main memory can be deleted. Data on the drive may be lost. The device may be damaged. Perform a hardware reset only in the case of an emergency.

1. Press the on/off switch for more than 4 seconds.
2. Alternatively, press the reset button.

Information on the position of the buttons is available in the section "Front panel (Page 13)".

Operating the device

5.1 Opening the front door

Procedure

1. Open the front door with the key.
2. Pull the front door to the side.

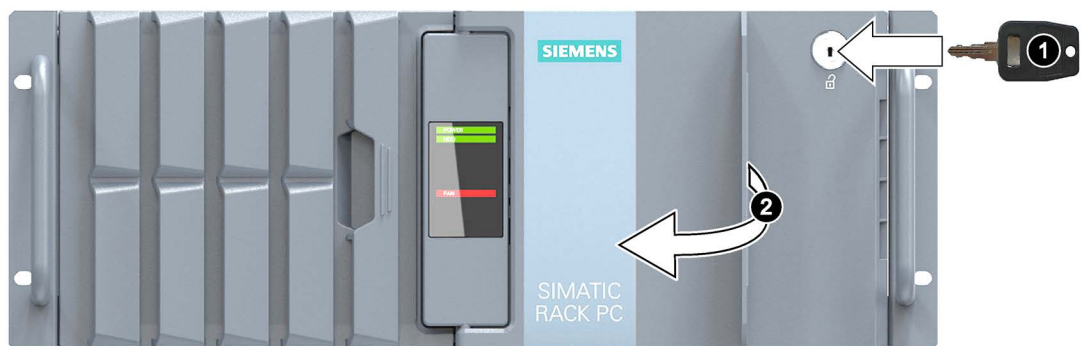

See also

Notes on ambient and environmental conditions (Page 26)

5.2 Drive configurations

5.2.1 Multi-disk system

The multi-disk system is an optional feature for the device. If you only use one drive type (full configuration), the following system limits apply:

- 2.5" drives: Maximum 8 (with maximum overall height of 15 mm)
- 3.5" drives: Maximum 4

Hard disks can be connected via SATA or corresponding drives via an additional SAS controller.

Booting from the second hard disk drive

In order to allow booting from the second hard disk drive, you need to configure it as the primary boot device (Boot Option #1). Make the following settings in your BIOS setup:

1. Select the "Boot" tab.
2. In the "Boot Option Properties" area, select the first entry from the list: "Boot Option #1" and press the Return key.
3. Select the corresponding drive (slave drive) in the "Boot Option #1" window, e.g. STxxxxxxx, and press the Return key.

The second hard disk drive (slave drive) becomes the primary boot device.

Note

The drive letters for the partitions on both drives are assigned by the operating system in use. You can change these in the Control Panel as required.

5.2.2 RAID systems

5.2.2.1 Manage RAID system

RAID system management functions

The following options are available for setting up a RAID system:

- RAID of the mainboard
- Hardware RAID of a RAID controller
- In devices with pre-installed Windows operating system: Software RAID with data storage media management, see section "Manage onboard RAID system (Page 46)".

Detailed information on drive replacement is available in section "Expansion and parameter assignment of device", "Replace defective hard disk in RAID system".

Note

A hard disk can be synchronized at operating system level if a fault is detected. It may take a very long time to synchronize a new hard disk in the background, depending on the size of the hard disk and on the system load. It may take several hours or even days in the case of extremely high hard disk load. Guide value for duration: < 3 h with 90% HDD system load and RAID5 with HDD 1 TB.

The safe system states RAID Level, for example, 1 are only reached once synchronization has been successfully completed. In addition, system performance may be limited in the case of a manually started maintenance operation until completion of the maintenance phase.

Note

Password protection for RAID setup

To prevent access to the optional ROM, follow these steps:

- Set the supervisor password in the BIOS setup.
- Disable keyboard operation during the BIOS self test (POST) in the BIOS setup.

You can find detailed information about the BIOS setup in the manual on the motherboard (Page 108).

Replacing a faulty drive in the RAID system

The faulty drive is indicated in the management software of the respective option. Replace the faulty drive with a new drive of the same type and capacity to return to the safe RAID1 or RAID5 status after a fault.

You can find detailed information on drive replacement in the following sections:

- "Expanding and assigning parameters to the device", "Replacing a defective hard disk drive in the RAID system (Page 70)"
- "Device maintenance and repair", "Manage onboard RAID system (Page 46)"

Integrating a new hard disk

A hard disk is integrated automatically into the RAID system if it fulfills one of the following requirements:

- The hard disk is brand new.
- The hard disk is set up as a global spare drive.
- The hard disk is set up as a dedicated spare drive.

5.2.2.2 RAID system of the motherboard

The RAID system of the motherboard is set up in the BIOS setup.

You can find more detailed information in the manual for the motherboard, section "BIOS setup", see section "Motherboard (Page 108)".

5.2.2.3 SAS/SATA hardware RAID system

SAS/SATA hardware RAID adapter card with dedicated CPU and cache memory:

- For applications with stringent requirements regarding low system disturbances of the RAID system.
- With maintenance-free battery backup for high data reliability.
- The RAID controller with PCIe x8 interface occupies one PCIe x8 or x16 expansion slot of the device.

Requirements for Adaptec Storage Manager software

The following requirements must be met before you use the software for the first time during commissioning:

- 4 GB main memory
- The operating system is restarted.
- The operating system is password-protected.
- Login and password of the operating system and Storage Manager software are the same.

Data is backed up to two or three SAS or SATA hard disks. As a result, the system is able to continue operation in the event of a defective hard disk or port connection problems, thereby achieving high availability. The 4-port or 8-port variant can be used.

An optionally available hot-spare drive can further increase the availability of the system.

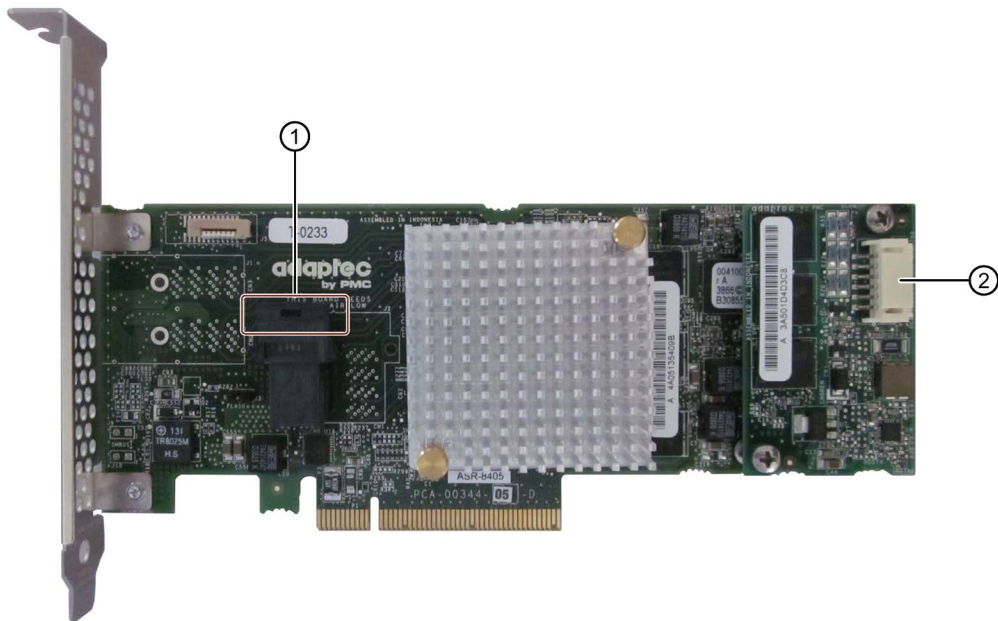

- ① Connection for the SAS/SATA data cable
- ② Connection for Zero Maintenance Module (ZMM)

The installed RAID controller for the "Adaptec RAID ASR8405" module is displayed as follows in the BIOS:

```
Adaptec RAID BIOS V7.5-0 [Build 32033]
(c) 1998-2014 PMC-Sierra, Inc. All Rights Reserved.

<<< Press <Ctrl><A> for Adaptec RAID Configuration Utility! >>>

Controller #00 found at PCI Slot:00, Bus:02, Dev:00, Func:00
Controller Model: ASR8405
Firmware Version: 7.5-0[32033]
Memory Size      : 1024 MB
Serial Number    : 4A05135406D
SAS WWN         : 50000D11079B6200
AFM700 Status   : Ready
Controller State: Normal

Dev#0 - RAID-5    119.99 GB    Optimal
1 Array(s) Found

BIOS Installed Successfully!
```

Additional software and documentation

Refer to the following software documentation from the manufacturer:

- Adaptec RAID Controller Quick Start Guide
The PDF file describes how you install the RAID controller and create a bootable RAID1 or RAID5 array. It also describes how you install the operating system and the controller driver on the array.
- Adaptec RAID Controller Installation and User Manual
The PDF file contains comprehensive information on installation and configuration of the RAID adapter card and the connected devices.
- Adaptec maxView Storage Manager User Manual
The PDF file contains comprehensive information on installation and use of Adaptec maxView Storage Manager.
- Command Line Utility User Guide
The PDF file contains the user manual for the command line utility program and comprehensive information on the use of ARCCONF.

In order to use the software, the operating system must be password-protected. The password must be assigned before the software is installed. In a correct installation, the operating system password and RAID software password are the same.

5.2.2.4 RAID1 system

The system can be configured as RAID1 (data mirroring on two hard disk drives). This means that if there is a defective hard disk or there are cable problems, the system can continue to operate in one channel and achieve a high degree of availability. You can find additional information in chapter "Manage onboard RAID system (Page 46)".

5.3 Operating RAID systems

5.3.1 Manage onboard RAID system

The RAID system of the manufacturer can also be used via the motherboard. The BIOS setup is used to set up this system. Additional information is available in the sections "RAID systems (Page 42)" and "Replacing a defective hard disk drive in the RAID system (Page 70)".

Note

The key combination <CTRL+I> is only effective in "Legacy" mode. If the "Boot Type" parameter is set to "UEFI Boot Type" in the "Boot" menu in the BIOS setup, the RAID hardware is configured by using the "Device Management" button in the BIOS selection menu.

5.3.1.1 Example for a RAID1 system during the boot phase of the system

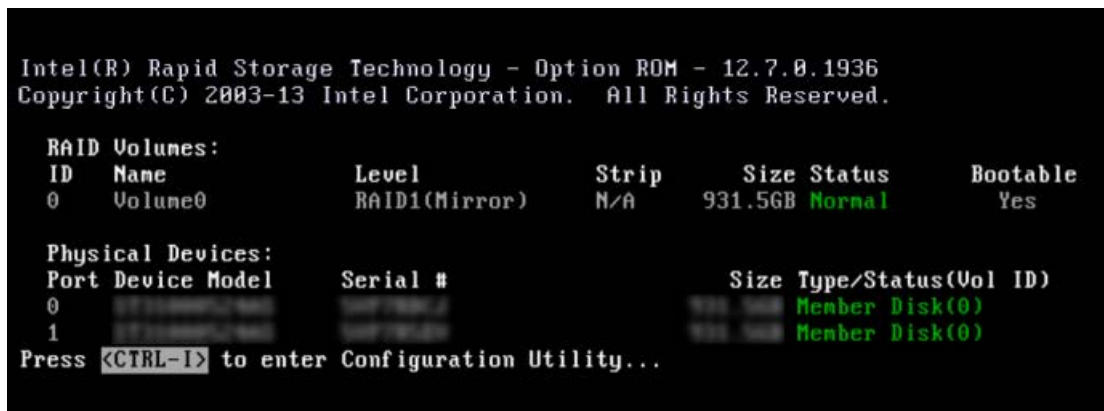

```
Intel(R) Rapid Storage Technology - Option ROM - 12.7.0.1936
Copyright(C) 2003-13 Intel Corporation. All Rights Reserved.

RAID Volumes:
ID Name Level Strip Size Status Bootable
0 Volume0 RAID1(Mirror) N/A 931.5GB Normal Yes

Physical Devices:
Port Device Model Serial # Size Type/Status(Vol ID)
0 ST1000PM0000 ST1000PM0000 931.5GB Member Disk(0)
1 ST1000PM0000 ST1000PM0000 931.5GB Member Disk(0)

Press <CTRL-I> to enter Configuration Utility...
```

5.3.1.2 RAID software

The free RAID software "Intel Rapid Storage Technology" offers additional advanced functions for the use and management of the RAID system.

1. Select the RAID software via "Start > Programs > Intel Rapid Storage Technology".

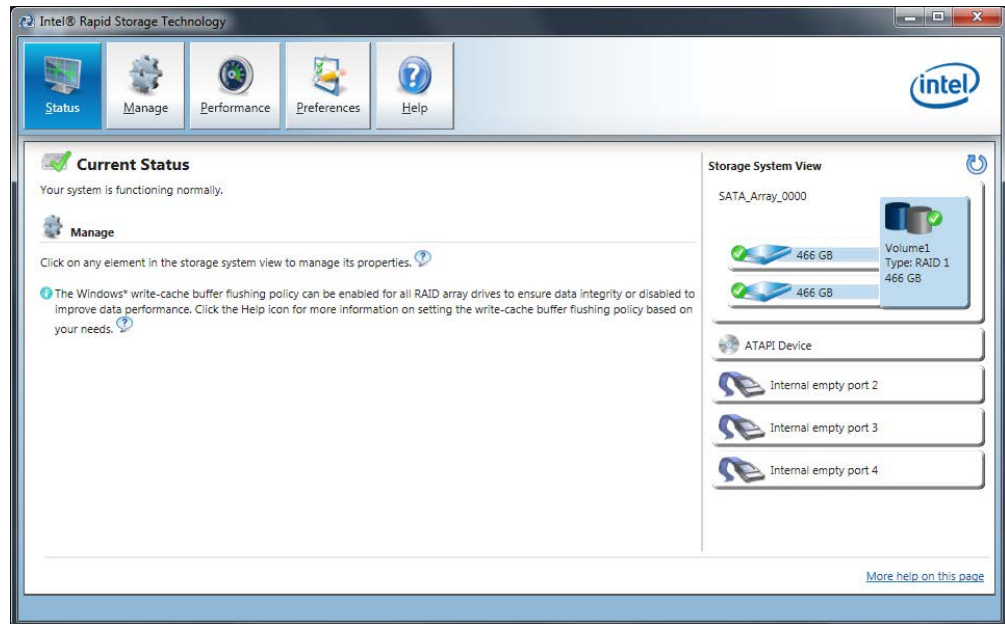

2. Select "Manage" > "Advanced" to display details of the RAID system.
3. Select "Help" > "System Report" > "Save" to create a report with the details of the RAID system.

5.3.1.3 Checking the status of the RAID system

By default, the status of the RAID system is displayed in the Windows Event Viewer and in a log file of the program. If an error occurs, a hard disk can be synchronized at the operating system level.

Note

It may take a very long time (hours or even days in the case of a high drive load) to synchronize a new hard disk in the background, depending on its size and on the system load. The redundant system state is reached again only after synchronization is completed.

NOTICE

Operator errors on the machine or plant

Data is synchronized if a hard disk fails. Depending on the work load of the processor and hard disks, the system may react with some delay. Execution of keyboard, mouse or touch screen commands may be briefly delayed in extreme situations. This could result in operator errors on the machine or plant.

Do not operate safety-critical functions when a hard disk has failed.

5.3.1.4 Displaying a defective hard disk of a RAID system in the RAID software

Note

Always replace the defective hard disk with a new hard disk of the same type and capacity.

In order to return to the safe RAID state after an error, the faulty hard disk must be replaced by a new hard disk.

The RAID software indicates the following:

- A defective hard disk
- Details of the functioning hard disk:

The functioning hard disk is indicated by BIOS with its port number or by the RAID software with its device port number.

The following figure shows the corresponding window in the RAID software with a RAID1 system.

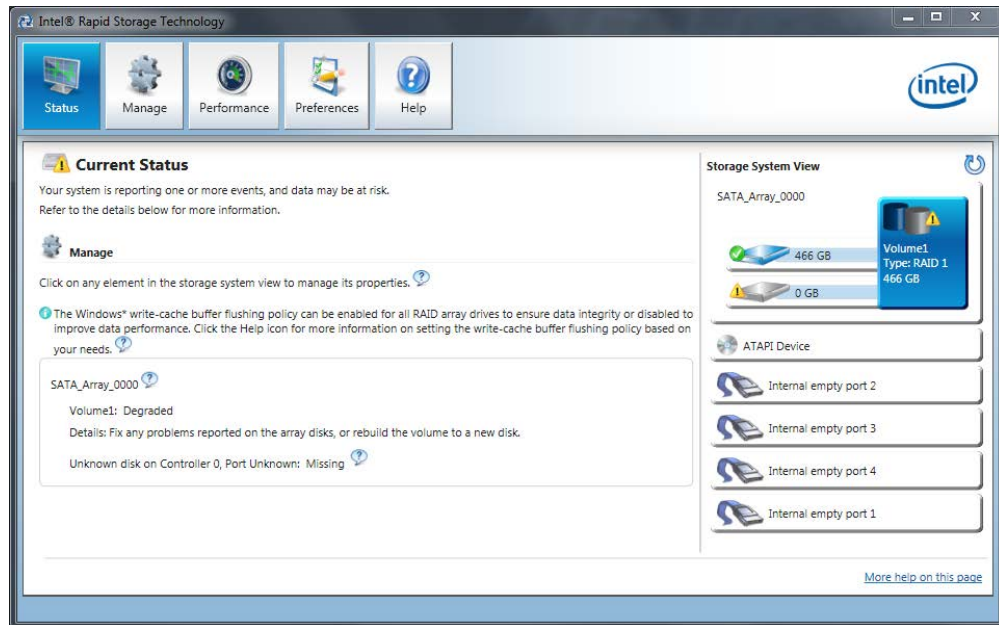

You can find information on how to detect and replace a defective hard disk in the RAID system in the section "Replacing a defective hard disk drive in the RAID system (Page 70)".

5.3.1.5 Special feature: Replacing hard disk in the RAID system when switched off

The RAID system does not automatically boot up when restarted if a defective hard disk was replaced while the RAID system is switched off. Therefore, place the RAID system in the first place of the bootable sources in the BIOS setup menu "Boot". Otherwise, the system will boot from the hard disk you have just installed and the message "Operating system not found" will be displayed.

5.3.1.6 Integrating a new hard disk drive in the RAID system

The RAID system is configured in the delivery state so that a new hard disk must be integrated manually in case of an error. To integrate the hard disk automatically, activate "Automatic rebuild" in the "Preferences" menu of the RAID software.

Automatic integration of a hard disk

NOTICE

Data loss

The hard disk to be integrated is not checked for partition information or existing data during automatic integration.

All partitions and data on the hard disk are deleted without warning. Insert only a brand-new hard disk.

Requirement:

- "Automatic rebuild" is selected in the "Preferences" menu of the RAID software.
- The hard disk to be integrated is brand new or is set up as a spare drive. Notes on creating spare drives are available in the controller documentation.

Sequence

The following figure is an example for the automatic rebuilding process.

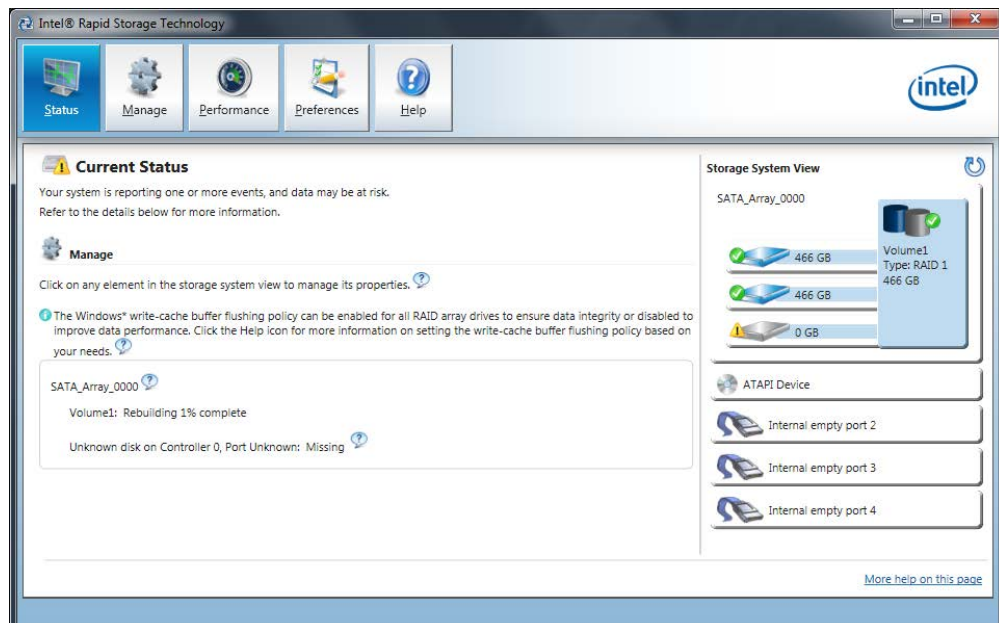

A defective hard disk is still displayed during the rebuilding process. This display disappears when the rebuilding process is completed.

Procedure - integrating hard disk manually

When the "Automatic rebuild" option is deselected in the "Preferences" menu of the RAID software (default setting), you must integrate the hard disk manually:

1. Select "Start" > "Programs" > "Intel Rapid Storage Technology".
2. Click  "Run Hardware Scan now".

The new hard disk is found and displayed.

Or:

1. Reboot the device.

The RAID software automatically integrates the hard disk.

2. Click the "Rebuild to another Disk" link.

The RAID system is synchronized.

The following figure shows the window when integrating a hard disk in a RAID1 system.

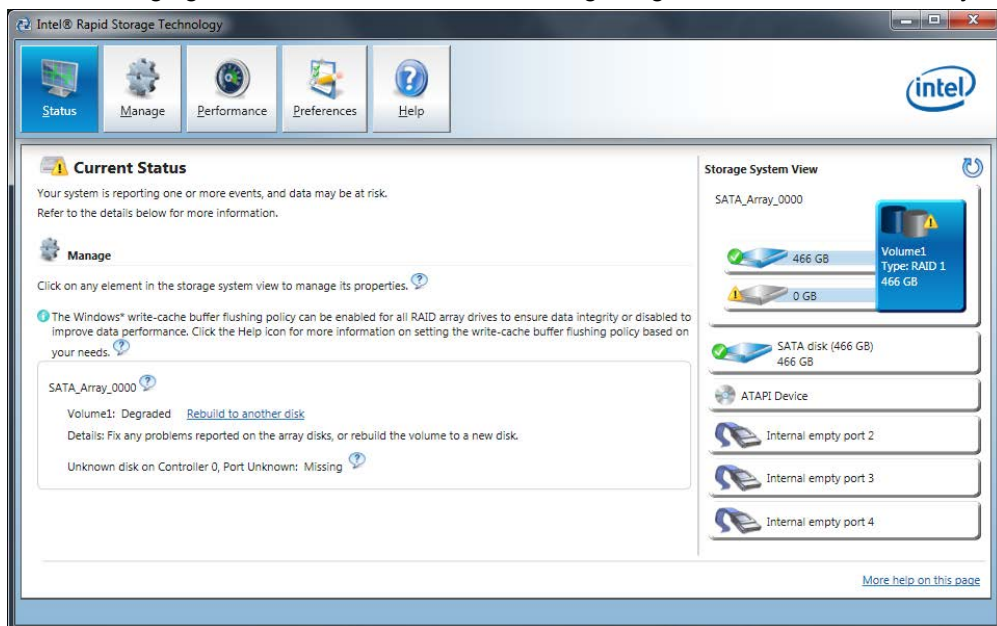

If you shut down and restart the system without installing a functioning new hard disk, "unused" is displayed for the corresponding SATA port. You can install the functioning hard disk while the system is running. The new hard disk is then assigned to a SATA port and is integrated into the RAID system.

A defective hard disk is still displayed during the rebuilding process. This display disappears when the rebuilding process is completed.

5.3.2 Managing the Hardware RAID system

The status of the RAID system is displayed via the Adaptec controller. Additional software is not required. Additional information is available in the sections "RAID systems (Page 42)" and "Installing and configuring the hardware RAID adapter card (Page 78)".

5.4 Monitoring functions

Sensors

Multiple sensors monitor the device:

- Temperature of processor, memory, mainboard and hard disk drives
- Temperature of optional graphics cards
- Speed monitoring of up to 6 fans
- Pulse Width Modulated PWM fan connections
- Voltage monitoring for processor, memory, other mainboard areas
- Power and status of power supply modules with redundant power supply (optional)

Monitoring options

There are two monitoring options: local monitoring and remote monitoring. For remote monitoring, the IPMI (Intelligent Platform Management Interface) is used for communication with the system.

An extensive collection of software for implementing a Healthmonitoring solution in various application scenarios is available on the Internet at IPMI (<http://www.supermicro.com/ipmi>).

Local monitoring

The device can be monitored locally, e.g. by tools such as SuperDoctor from Supermicro. These enable sensor scans and control functions to be performed in a web interface or with the command line.

Remote monitoring

Remote monitoring of one or more devices with the IPMIView software from Supermicro is another option. IPMIView is a management software for remote maintenance of multiple terminals in a network. Among the functions provided by IPMIView are the following:

- Configuration management with IP address assignment
- Firmware update
- Access protection with user and PC group management
- Password assignment and login
- Sensor monitoring, e.g. battery status, temperature
- Power management with remote switch-on and switch-off of system
- System access at BIOS level
- Integration of virtual media, e.g. installation medium
- Event display with logging
- KVM console (KVM-Over-IP for Video Redirection)

5.5 Trusted Platform Module (TPM)

Your device can have a Trusted Platform Module up to TPM 2.0 The Trusted Platform Module is a chip that enhances your device with security functions. It provides an improved protection from manipulation of the PC. The current Windows operating systems support these security functions. You can enable the Trusted Platform Module in the "Security" menu in the BIOS Setup. Please note the respective import and export provisions for the Trusted Platform Module.

Using the Trusted Platform Module

The TPM can be used with the "BitLocker" drive encrypter, for example, in Windows operating systems. Please follow the instructions for this in the operating system.

Note

Risk of data loss

If you lose the password for the drive encryption, you will not be able to restore the data. You will then lose access to the encrypted drive.

The warranty does not cover a reset of the hardware in the event of a loss of a password.

Please store the password carefully and make sure it is protected against unauthorized access.

Expanding and assigning parameters to the device

6.1 Open the device.

 WARNING
<p>Risk due to unauthorized opening and improper repairs or expansions</p> <p>Improper procedures when carrying out expansions may result in damage to equipment or endanger the user.</p> <p>If you install or exchange system expansions and damage your device, the warranty becomes void.</p> <p>For this reason, please make sure to observe the information in "Notes on ambient and environmental conditions (Page 26)".</p>

 WARNING
<p>Malfunctions and electric shock</p> <p>Improper intervention in the device endangers operational reliability and may damage the device.</p> <p>The results are personal injuries and damage to the plant.</p> <p>Take the following precautions:</p> <ul style="list-style-type: none"> • Disconnect the power plug before you open the device. • Close the device after every intervention.

NOTICE
<p>Electrostatic sensitive devices (ESD)</p> <p>The device contains electronic components that may be destroyed by electrostatic charges. This can result in malfunctions and damage to the machine or plant.</p> <p>Take corresponding precautionary measures when you open the device.</p>

Requirement

- The device is fully disconnected from the line voltage, see section "Switching off the device (Page 39)".
- All connecting cables are unplugged
- The front door is open; see section "Opening the front door (Page 41)".
- Tx10 screwdriver

Procedure

Similar to figure

1. Loosen the 4 marked screws on the side.
2. Remove the captive screw on the front panel, see also section "Front panel (Page 13)".
3. Slide the enclosure cover backwards in the 4 slotted holes to the end of the slotted holes.
4. Remove the cover upwards vertically and evenly without tilting it.

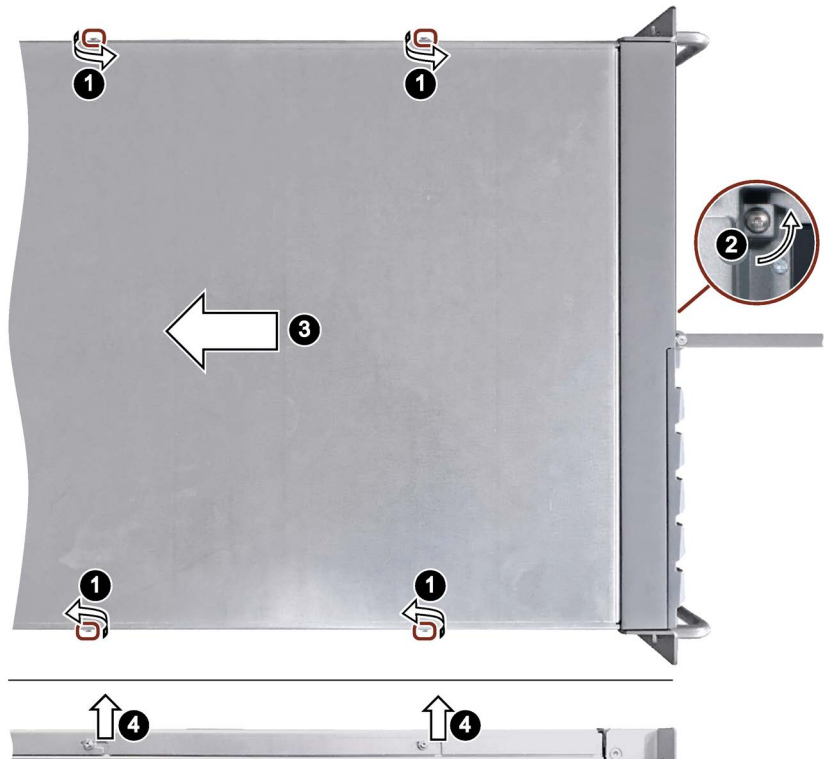

To close the device, proceed in the reverse order.

6.2 Drives

6.2.1 Overview

Depending on the configuration, the device is equipped with drive cage type A for removable drives or drive cage type B for permanent installation of drives.

Drives in drive cage type A

The following applies to devices with drive cage type A:

- Maximum configuration: 4 × 3.5" or 2.5" drives in removable drive bay
- Permissible operating temperature range: 0 ... 40 °C

Installation options

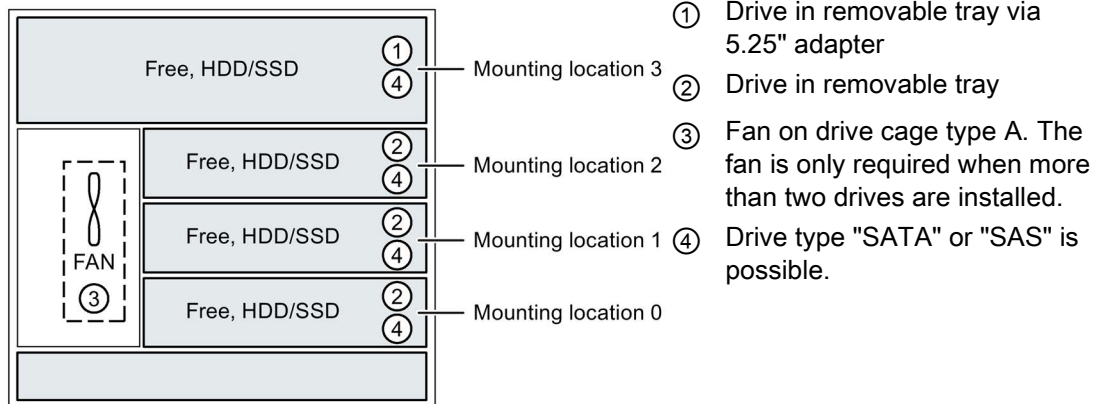

Drives in drive cage type B

The following applies to devices with drive cage type B:

- Maximum configuration: 4 × 3.5" or 8 × 2.5" ¹ drives
- Permissible operating temperature range: 0 ... 50 °C ²

Installation options

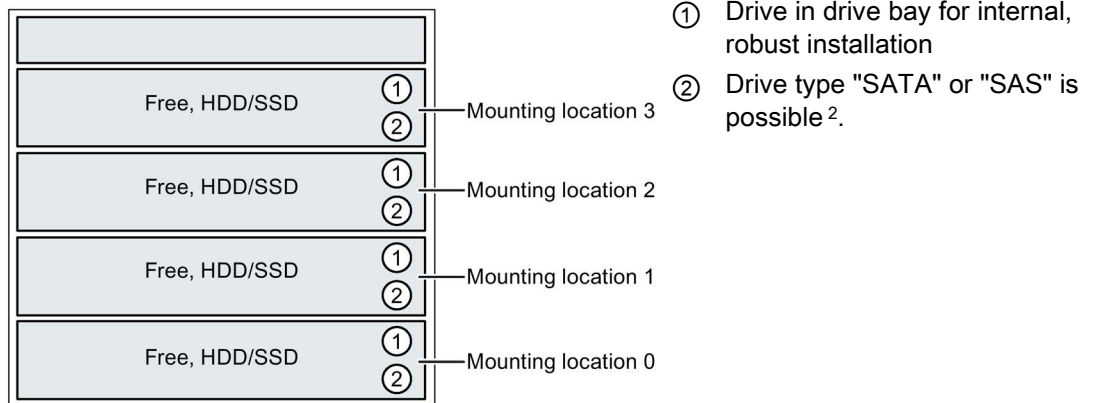

¹ With maximum overall height of 15 mm

² Restriction: A maximum of 40°C is permissible with SAS drives.

6.2.2 Drives in drive cage type A

6.2.2.1 Change 2.5" and 3.5" drive in removable tray

NOTICE
Risk of damaging the drive and data loss
Drives in removable drive bays can only be replaced during operation in connection with RAID1 and RAID5 (hot swap).
When you remove the drive while data is being written to it, you may damage the drive and destroy data.
<ul style="list-style-type: none">• Only remove the removable tray from the device when the drive is inactive, see section "Status displays on removable tray for drives (Page 19)".• Observe the ESD guidelines.

Requirement

- The device is equipped with the drive cage type A.
- An original spare part, i.e. a drive approved for this device, see notes in section "Accessories and spare parts (Page 20)".
- If there is no RAID system: The device is fully disconnected from the line voltage, see section "Switching off the device (Page 39)".
- The device you wish to replace is inactive.
- When replacing an HD: T10 screwdriver
- When replacing an SSD: T8 screwdriver

Procedure

1. Open the front panel (Page 41).
2. Open the lock of the removable tray with the appropriate key.



3. Reach into the notch ① in the bracket of the removable tray and pull out the bracket in the direction of the arrow up to a slight resistance.

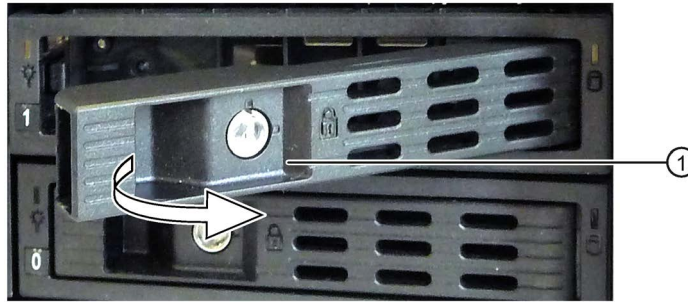

The removable tray is pushed out of the drive cage slightly levering.

4. Now grip the removable tray from the front in the middle at the top and bottom, and pull the removable tray completely out of the device.
5. Loosen the highlighted screws on the bottom of the removable tray and remove the drive.

The figure on the left shows an HDD as the drive and the figure on the right shows an SSD.

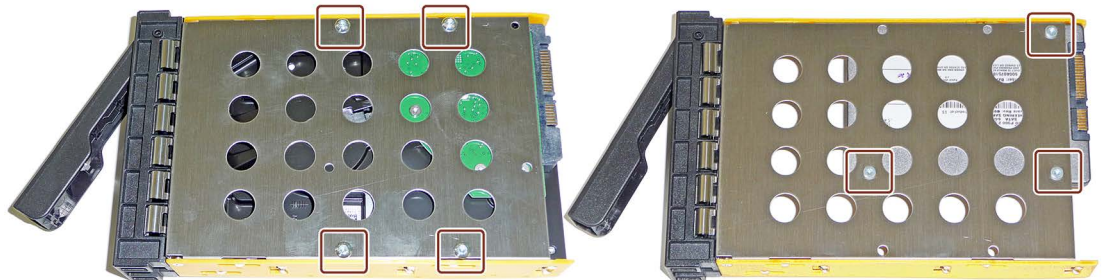

6. Carefully insert the new drive into the removable tray.
Take care not to touch the contacts of the drive when you do this.
7. Fasten the new drive with the screws to the base of the removable tray.
Only use the original screws.
8. Carefully insert the removable tray into the drive cage of the device again.
9. Fold the tray bracket out of the removable tray as far as it will go and slide the removable tray fully into the drive cage.
Ensure that the removable tray fits tightly in the drive cage.
10. Close the tray bracket.
11. Lock the removable tray with the key.

Note

The removable tray must always be locked to ensure reliable operation of the devices with removable trays.

6.2.2.2 Installing a 5.25" adapter module for removable trays

Requirement

- The device is equipped with the drive cage type A.
- There is no drive or any other component in the mounting location for 5.25" components.
- An original spare part, that is a 5.25" adapter module approved for this device, see notes in section "Accessories and spare parts (Page 20)".
- The device is fully disconnected from the line voltage, see section "Switching off the device (Page 39)".
- The device is open; see section "Open the device. (Page 53)".

Procedure

1. Unlock the drive mounting bar together with the blanking plate by pressing laterally against the surfaces ① and push the drive mounting bar forward from the device in the direction of the arrow.

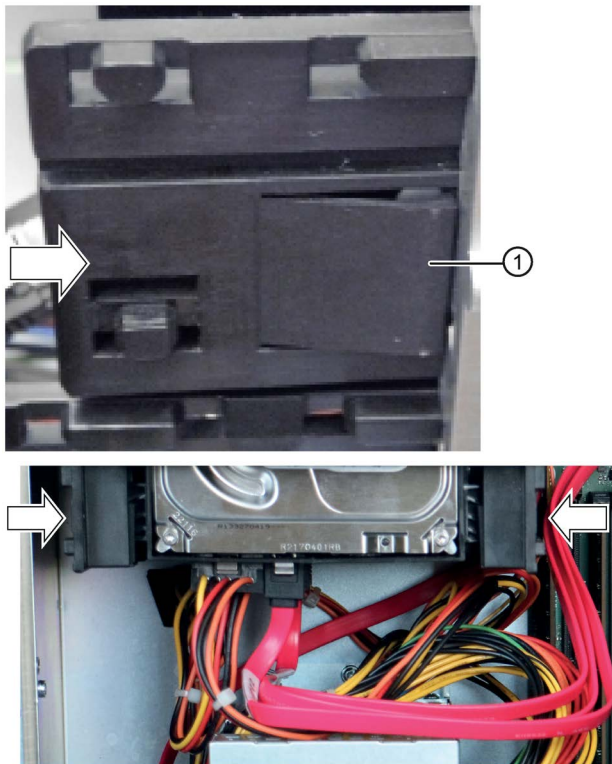

2. Remove the blanking plate.

3. Push the 5.25" adapter for the removable racks from the front into the drive cage.



4. Attach the data cables to the desired connectors on the motherboard or the hardware RAID controller and to the adapter module.
5. Connect the power supply.
6. Close the device.

6.2.2.3 Installing a backplane for removable tray

The backplane is installed from inside at the back end of the drive cage type A and is equipped with interfaces for data cable to the motherboard.

This enables the convenient connection of the data cables from the motherboard to the drive in the removable tray at these interfaces.

Requirement

- An original spare part, that is a backplane approved for this device, see notes in section "Accessories and spare parts (Page 20)".
- The device is fully disconnected from the line voltage, see section "Switching off the device (Page 39)".
- The device is open; see section "Open the device. (Page 53)".

Procedure

1. Press the locks ① of the cover ② together inside the device and keep them pressed.

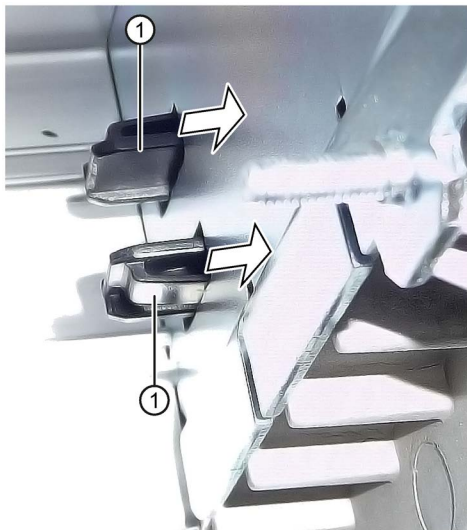

2. Push the locks to the front in the direction of the arrow.
3. Remove the cover ② upwards at an angle at the front of the device.



4. Remove the blanking plates ③ which may be located to the right of the cover at the front of the drive cage.
5. Remove all existing removable trays until the drive cage is freely accessible.

6. Insert the backplane ④ into the drive bay from the front and snap it into place at the back.

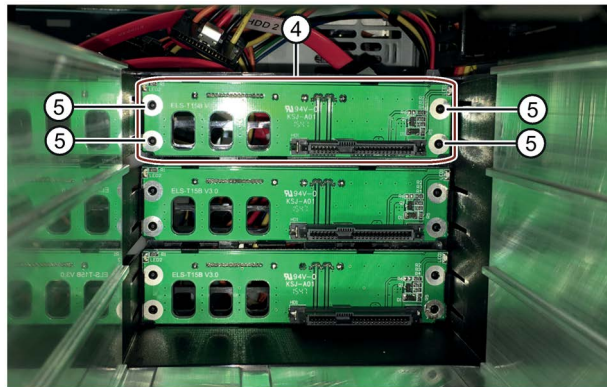

Check the following:

- The backplane lies flat at the back in the drive cage.
- All centering openings ⑤ of the backplane lie in the centering pins.
- The backplane is clipped in behind the latches ⑥.
- All backplanes lie exactly underneath each other, vertically aligned, when viewed from above ⑦.

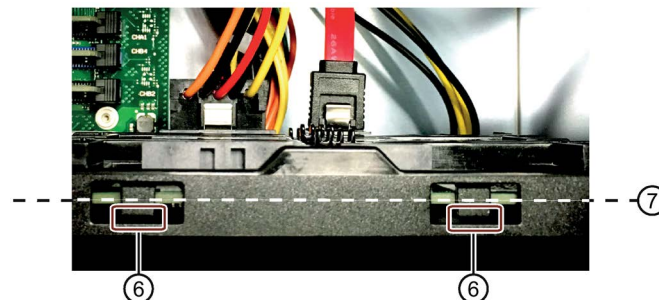

7. Reinstall the required blanking plates or removable trays.
8. Insert the cover ② into the front of the device.
9. At the backplane, connect the data cables with the corresponding interfaces on the motherboard or the hardware RAID controller.
10. Connect the power supply.
11. Close the device.

6.2.2.4 Changing a backplane for removable tray

The backplane is installed from inside at the back end of the drive cage type A and is equipped with interfaces for data cable to the motherboard.

This enables the convenient connection of the data cables from the motherboard to the drive in the removable tray at these interfaces.

Requirement

- An original spare part, that is a backplane approved for this device, see notes in section "Accessories and spare parts (Page 20)".
- The device is fully disconnected from the line voltage, see section "Switching off the device (Page 39)".
- The device is open; see section "Open the device. (Page 53)".

Procedure

1. Note the assignment of all data cables to the motherboard and disconnect all data cables ①.

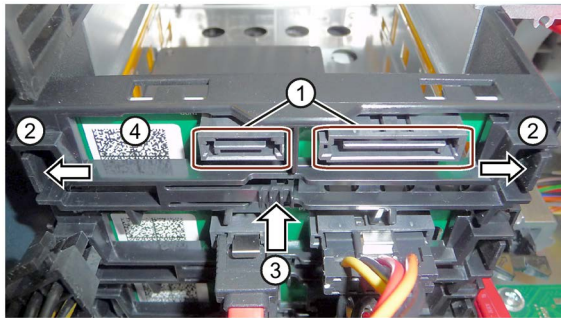

2. Unlock the backplane by pressing firmly in the direction of the arrow on the latching lugs ② and press the ejector ③.
3. Remove the unlatched backplane board ④ by turning it upwards from the brackets and removing it from the drive cage.

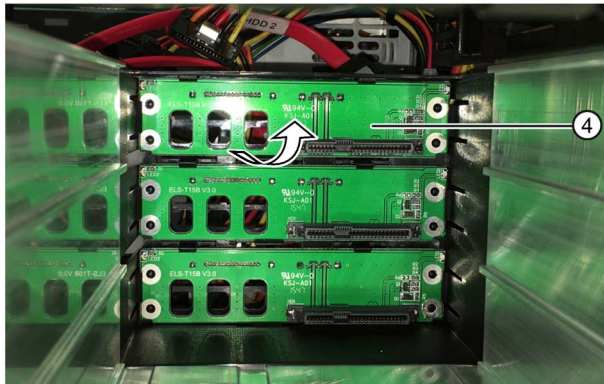

See also

Installing a backplane for removable tray (Page 59)

6.2.3 Drives in drive cage type B

6.2.3.1 Overview

You can mount the following drives and storage media in the device:

- Hard disk drive
- Solid State Drive

Note

Vibratory loads

During operation, the HDDs must not be exposed to vibratory loads and may only be exposed to limited shock loads, see section "Technical specifications (Page 101)".

Tolerances for tightening torques

Unless otherwise specified, the tolerances of the torques specified in these operating instructions for tightening of screws is $\pm 10\%$.

Drive cage

The drive cage is used to hold removable trays in which the drives, e.g. HDDs and SSDs, are installed.

The figure below shows the rear view of the drive cage with open device. The bottom three trays in the drive cage are equipped as follows:

- Tray 3: 2 × 2.5" drives, horizontal format
- Tray 2: 2 × 2.5" drives, horizontal format
- Tray 1: 1 × 2.5" drive, vertical format

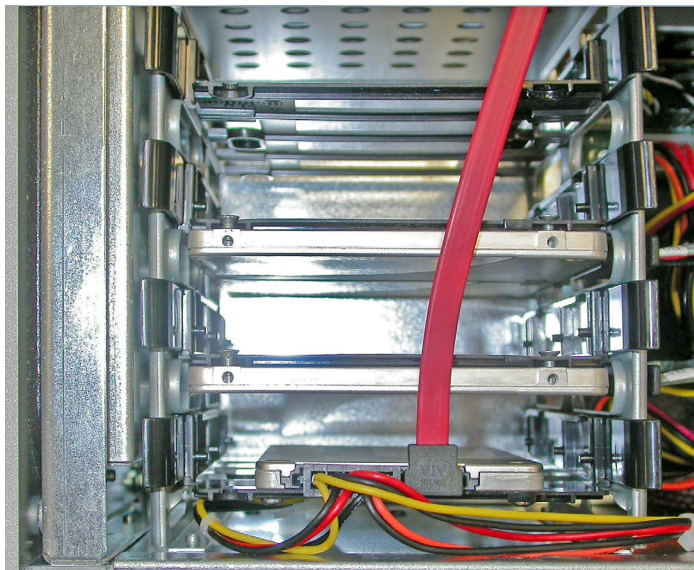

Additional mounting location: An additional hard disk drive can be installed between the top mounting location and the enclosure wall.

Installation options

3.5" drives, height of 26.1 mm:

- Full configuration
 - 1 × 3.5"
 - 1 × 3.5"
 - 1 × 3.5"
 - 1 × 3.5"

Note

Restriction on additional mounting location with maximum configuration

For the maximum configuration with 3.5" drives, only a 2.5" drive with a height of 7.5 mm can be additionally installed.

2.5" drives, height of 7.5 mm or 12.5 mm:

- Full configuration: A tray can accommodate two 2.5" drives in horizontal position (with maximum overall height of 15 mm):
 - 2 × 2.5"
 - 2 × 2.5"
 - 2 × 2.5"
 - 2 × 2.5"
- Mixed installation:
 - 1 × 3.5"
 - 1 × 3.5"
 - 1 × 2.5"
 - 1 × 2.5"

6.2.3.2 Removing and installing a tray from/in the drive cage

Requirement

- The device is open; see section "Open the device. (Page 53)".
- 1 soft, grounded mounting base

Procedure

Removal

1. Detach the marked connection cables from the relevant drive.
2. Press the side rails of the tray inwardly and simultaneously lift them up and out of the drive cage.
3. Place the tray on the mounting base.

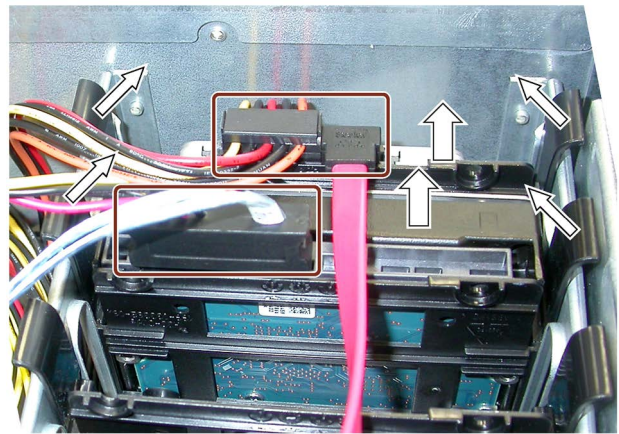

Installation

Proceed in the reverse order for the installation. Ensure that the tray latches in the bottom of the drive cage.

6.2.3.3 Removing and installing 3.5" drives from/in tray

Requirement

- The tray has been removed, see section "Removing and installing a tray from/in the drive cage (Page 65)".
- 1 drive
- 1 soft mounting base

Procedure

Removal

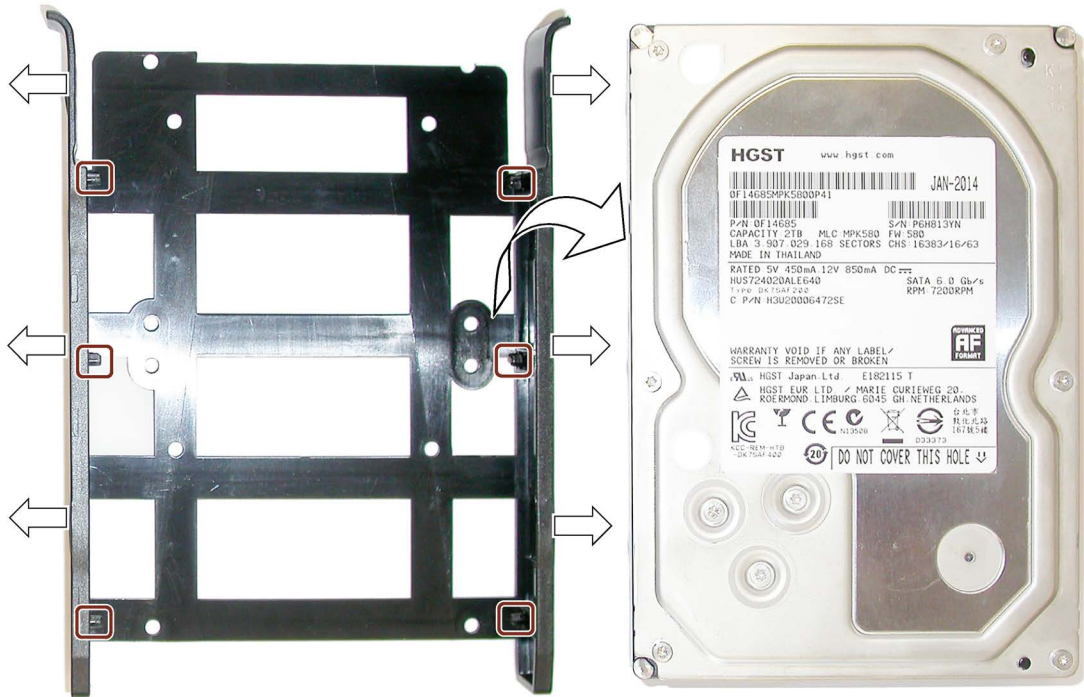

1. Place the tray on the mounting base so that it rests as shown.
2. Pull the two guides of the tray outwardly until the marked nipples release the drive.
3. Only touch the sides of the drive.
4. Remove the drive by lifting it upwards, and place it carefully on the mounting base next to the tray.

Installation

Proceed in reverse order.

6.2.3.4 Removing and installing 2.5" drives from/in tray

Requirement

- The tray has been removed, see section "Removing and installing a tray from/in the drive cage (Page 65)".
- 1 drive
- 1 soft mounting base

Procedure

Removal

1. Place the tray with the drive (nameplate) on the bottom on the mounting base as shown in the figure.

In the following figure, the installation in vertical format is shown on the left and the installation in horizontal format on the right.

2. Unscrew the highlighted screws.
3. Lift up the tray and place it on the mounting base next to the drive.

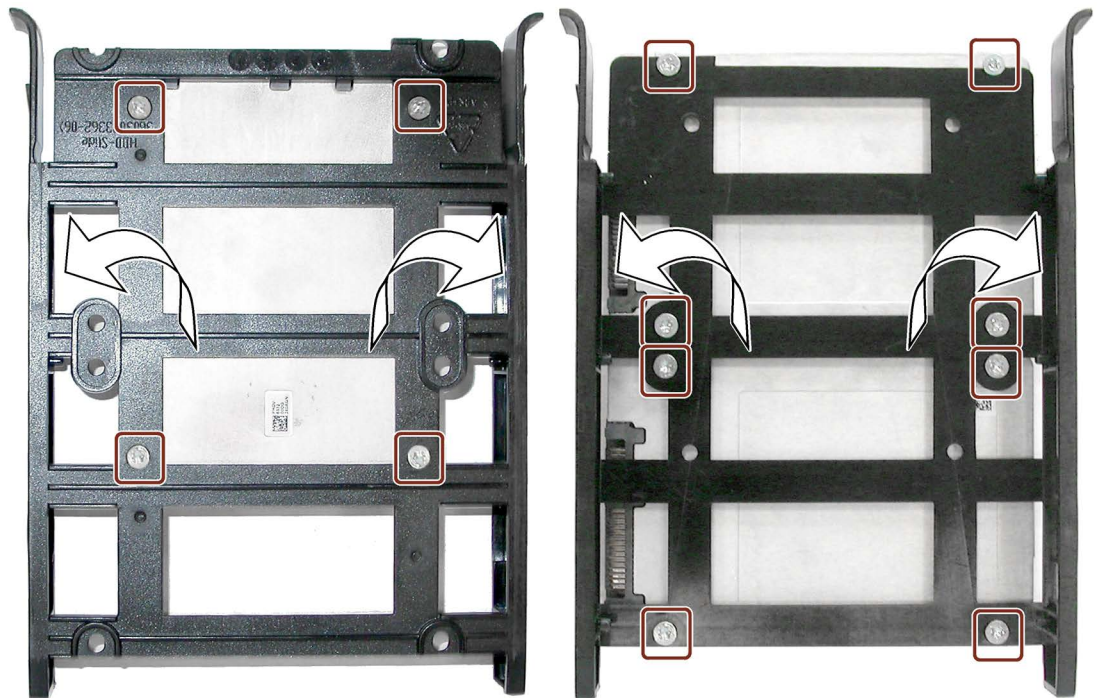

Installation

1. Place the drive next to the tray as shown. Make sure that the threads and holes are even.
2. Touching only the sides of the drive, move it left into the tray while keeping it even.
3. Fix the drive and tray in position at the center and carefully turn both over: the drive (rating plate) faces downward, see figure above.

Ensure that each hole of the tray is positioned exactly over the threads of the drive.

4. Screw on the drive from behind. Do not tighten the screws too much. Do not exceed the maximum tightening torque of 0.7 Nm.

Installation in vertical format

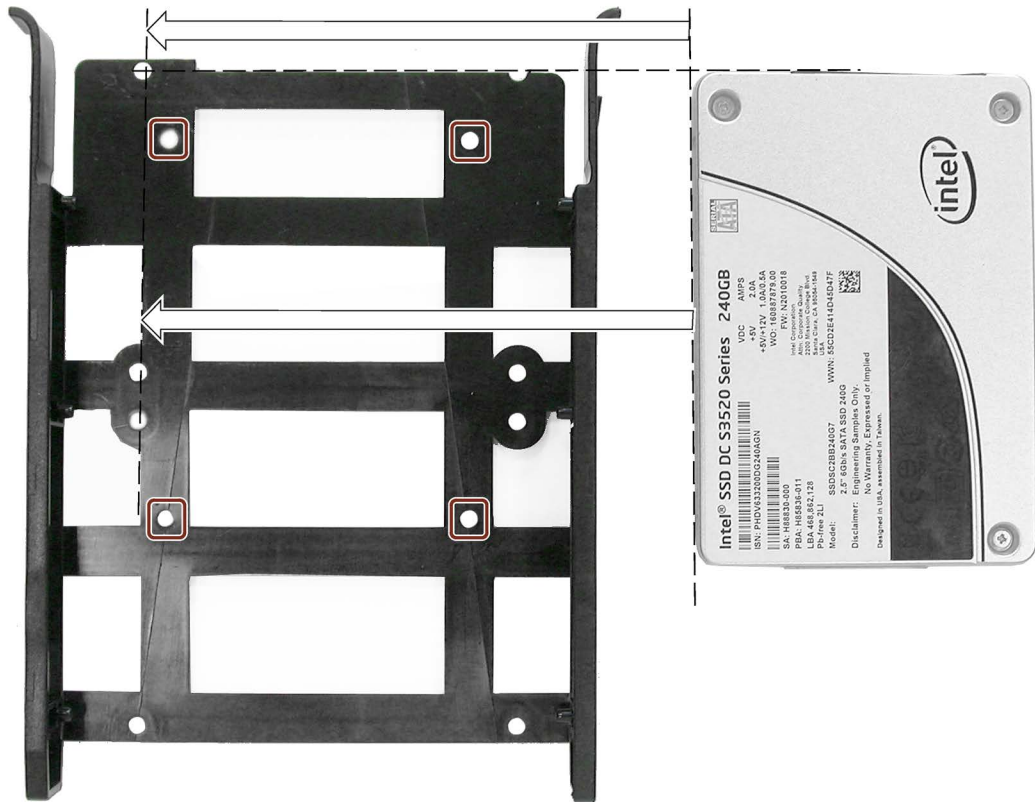

Installation in horizontal format

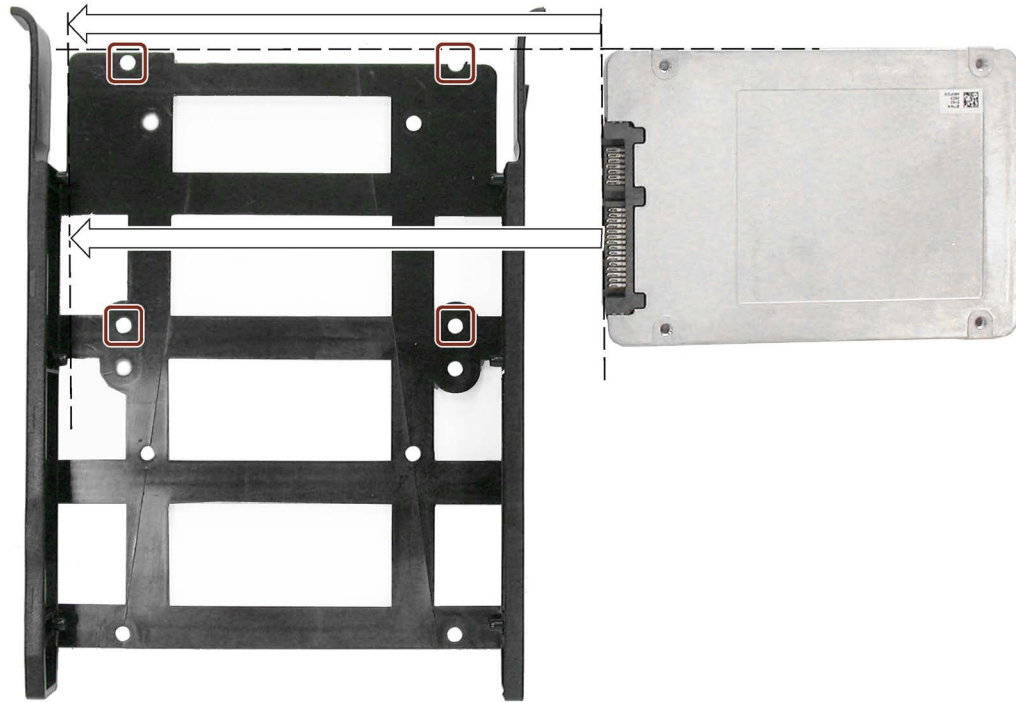

Result

In the following figure, the installation in vertical format is shown on the left and the installation in horizontal format on the right.

- For installation in vertical format, the drive lies inside the tray.
- For installation in horizontal format, the drive lies outside on the tray.
- For installation in horizontal format, you can mount two drives one above the other.



6.2.4 Replacing a defective hard disk drive in the RAID system

Observe the ESD guidelines. Always replace the drive with a new drive of the same type and capacity.

Mounting locations for hard disk drives in the RAID1 system

Hard disk drives for a RAID system can be installed internally in the device.

Note

An internal hard disk drive may only be replaced when the device is switched off.

The new hard disk drive can be integrated into the RAID1 system at operating system level with the RAID software. Synchronization may take several hours, depending on system load.

Replacing a defective hard disk drive in the RAID system

1. Determine which hard disk was reported by the RAID software as defective.
2. Replace the defective hard disk.
3. Replace the defective hard disk with a hard disk of the same type and capacity.

See also

Drives in drive cage type A (Page 56)

Drives in drive cage type B (Page 63)

6.3 Expansion cards

6.3.1 Notes on the expansion cards

Slot numbering

The figure below shows the numbering of the slots. For more detailed information from the manufacturer, see section "Motherboard (Page 108)".

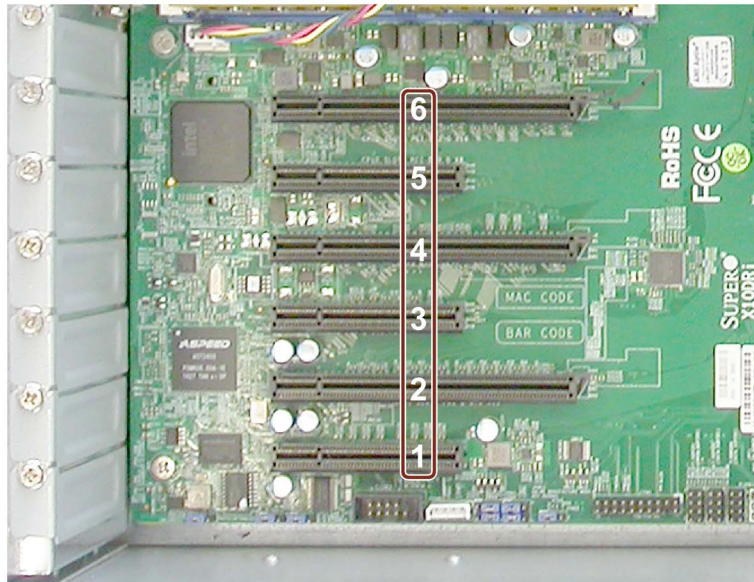

Note

Restrictions on use of slots

- A graphics card occupies one slot (single slot) or two slots (dual slot).
- Two dual-slot graphics cards can be installed on the motherboard in slots 1-2 and 3-4. There is then no more space for the second COM interface.
- The second COM interface needs slot 1. Use slots 3-4 for a dual-slot graphics card in this case.
- Do not use a fanless graphics card and a self-venting graphics card at the same time. Only use graphics cards with the same fan type: only fanless graphics cards or only self-venting graphics cards.

Note about long PCIe expansion cards

In the case of long PCI/PCIe expansion cards, connections on the motherboard can become hidden.

Note on PCI Express expansion cards

An expansion card or graphics card can occupy two slots in each case.

See also

Dimension drawing of the expansion cards (Page 110)

6.3.2 Configuration variants

Temperature range 0 °C to 50 °C (basic configuration)

Basic configuration without expansion cards

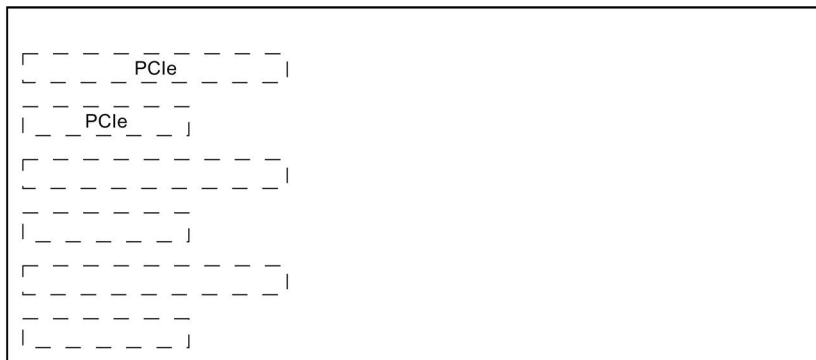

Temperature range 0 °C to 40 °C (maximum configuration)

Expansion up to 6 expansion cards: The maximum total power loss of all expansion cards is 200 W.

Maximum permitted configuration

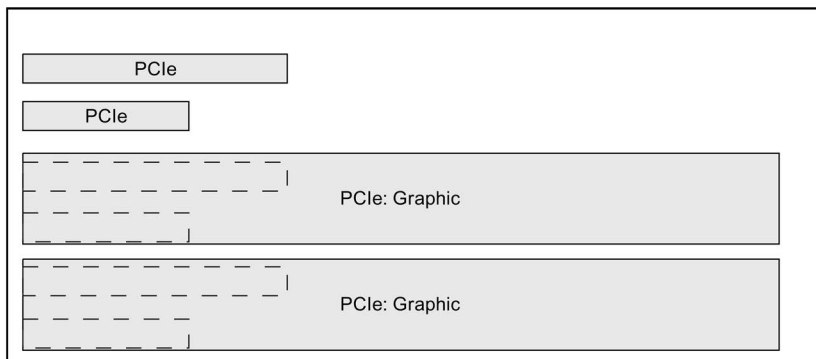

6.3.3 Installing and removing expansion cards

Requirement

- Tx10 screwdriver

Procedure

Installation

1. Remove the screw ③ at the relevant slot and take out the associated slot bracket, similar to the figure.
2. Insert the expansion card into the slot in the arrow direction.
Slide the expansion card into the slot as far as it will go without tilting the card.
3. Secure the expansion card with the corresponding screw.

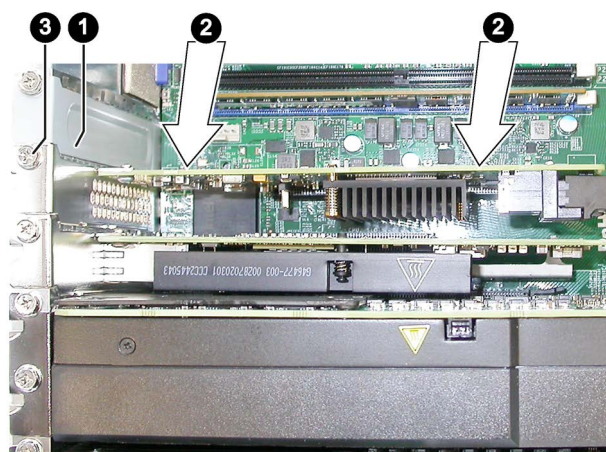

Removal

Proceed in the reverse order for the removal. In step 2, unlock the expansion card in the slot before removing it.

6.3.4 Installing the PCI expansion kit (optional)

Requirement

The PCI expansion kit consists of the following components:

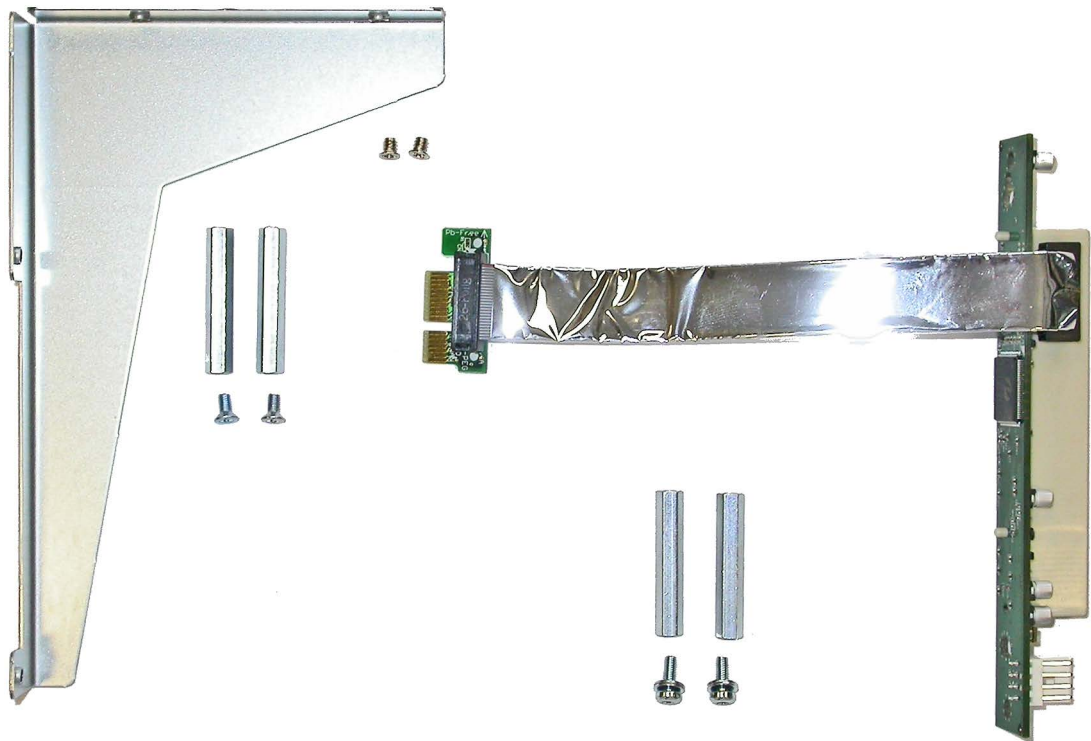

- Card retainer
- Fixing pins and screws
- Riser card with slot for PCI expansion card

Procedure

The PCI expansion card shown in the following serves as an example only.

1. Screw the fixing pins onto the riser card.

Place the fixing pins onto the inside of the enclosure and screw them in place from the outside.

2. Connect the riser card to the motherboard at the marked position.

3. Release the lock ⑤ (see step 5) and remove the slot bracket cover.

Place the expansion card onto the marked slot of the riser card.

Slide the expansion card into the slot in the arrow direction as far as it will go without tilting the card.

Note the following:

- The guide rail runs through the eye ③ on the left.
- On the outside, the guide rail bracket runs into the locking mechanism ⑤.

4. In the case of a longer PCI expansion card, place a card retainer onto the enclosure from the inside and screw it in place from the outside.

5. Press the outside of the guide rail bracket against the locking element and screw it in place, as shown.

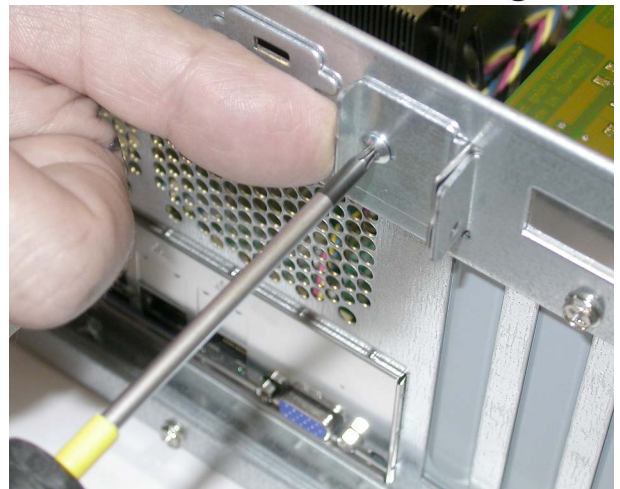
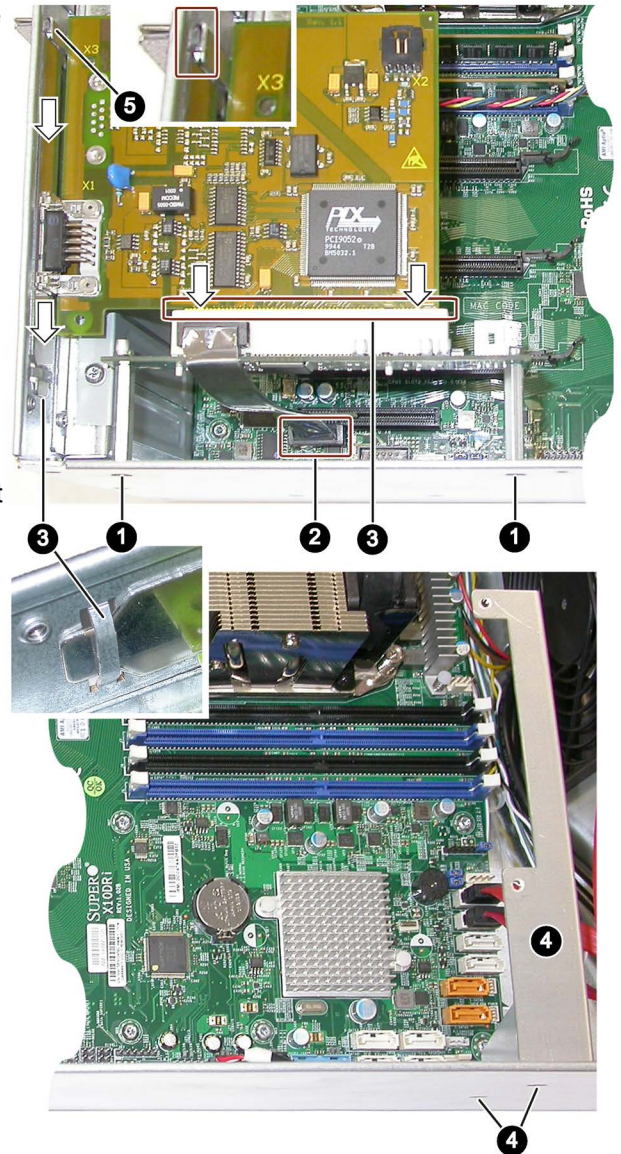

6.3.5 Removing and installing the graphics card

Below as example for the NVIDIA Quadro P5000 graphics card.

Requirement

- The device is open in accordance with section "Open the device. (Page 53)".
- Tx10 screwdriver
- Phillips screwdriver

Procedure

⚠ WARNING
Danger of injury by rotating parts
The fan blades rotate in the self-ventilated graphics card. Even after the device is switched off, the fan blades continue to rotate for a while. There is a risk of injury at the rotating parts of the fan, e.g. through cutting.
<ul style="list-style-type: none">• Wait until the fan blades come to a standstill.• Only then should you remove the graphics card.

Removal

1. Remove the two screws ① of the expansion card.

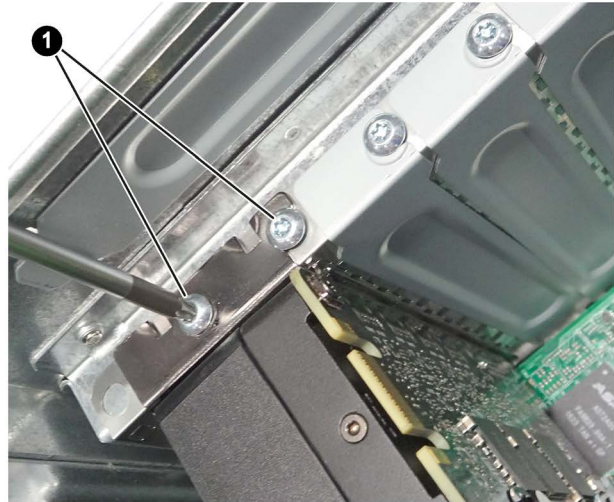

Also remove the two screws of the card retainer ③ on the outside.

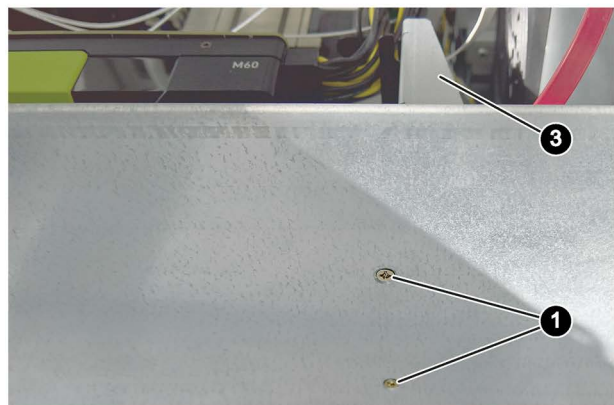

2. Remove the plug ②.
3. Remove the card retainer upwards and backwards as shown.
4. Release the locking mechanism on the socket, remove the graphics card ④ together with the support adapter ⑥ and place it carefully on the mounting base. The modules face down.

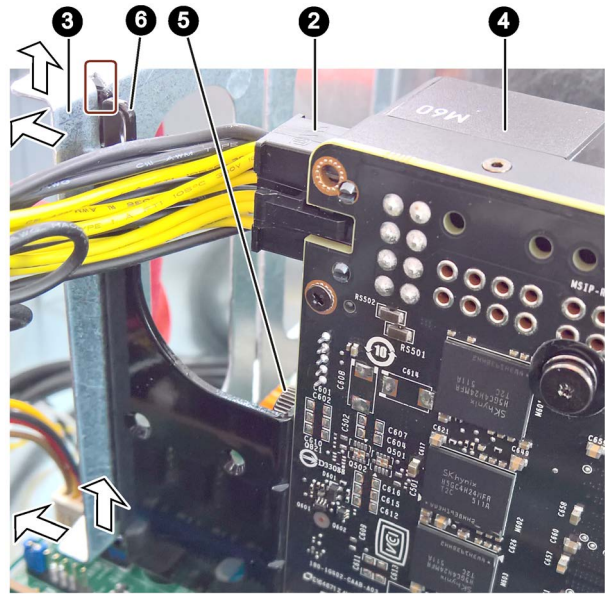

5. Loosen the screws ⑤ on the graphics card ④.
6. Remove the support adapter ⑥ forwards.

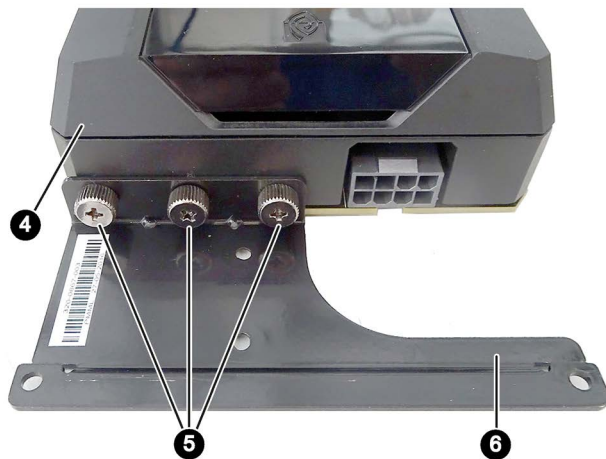

Installation

Proceed in the reverse order for the installation of the graphics card. In step 3, push the card retainer fully forward and downward onto the support adapter. Ensure that the support adapter is fully inserted into the groove of the card retainer as shown.

6.3.6 Installing and configuring the hardware RAID adapter card

This section describes how you install and configure a RAID adapter card, based on the example of ASR-8405. The description applies equally to other permissible RAID adapter cards.

Requirement

For installation of the hardware RAID adapter card, you require the following:

- Tx10 screwdriver
- The hardware RAID adapter card with connection for the SAS/SATA data cable ① and connection for the capacitor block of the ZMM ②

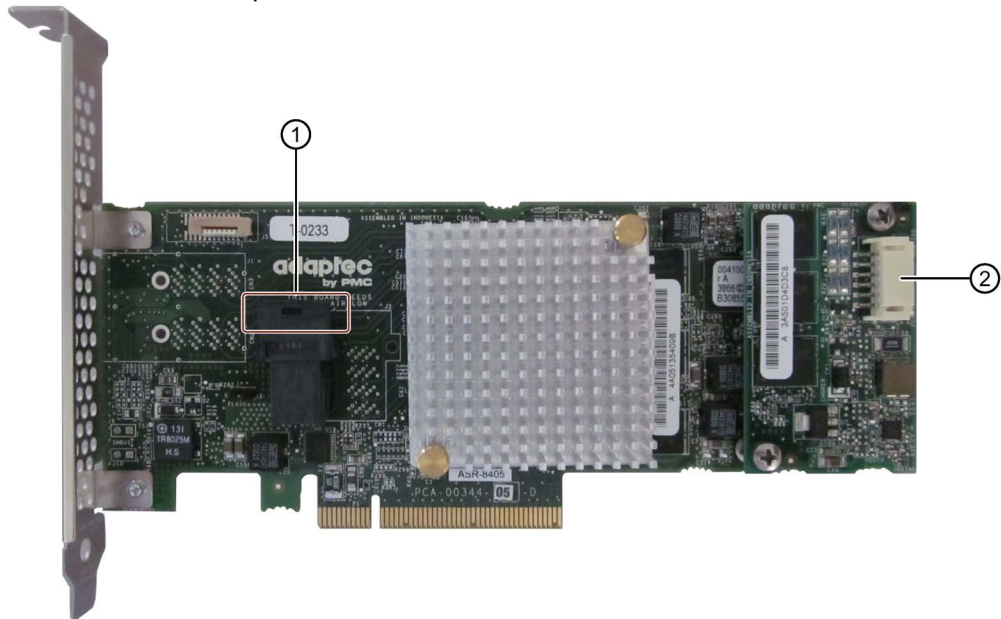

- An adapter cable for connection of the hard disk drive ① to the RAID module

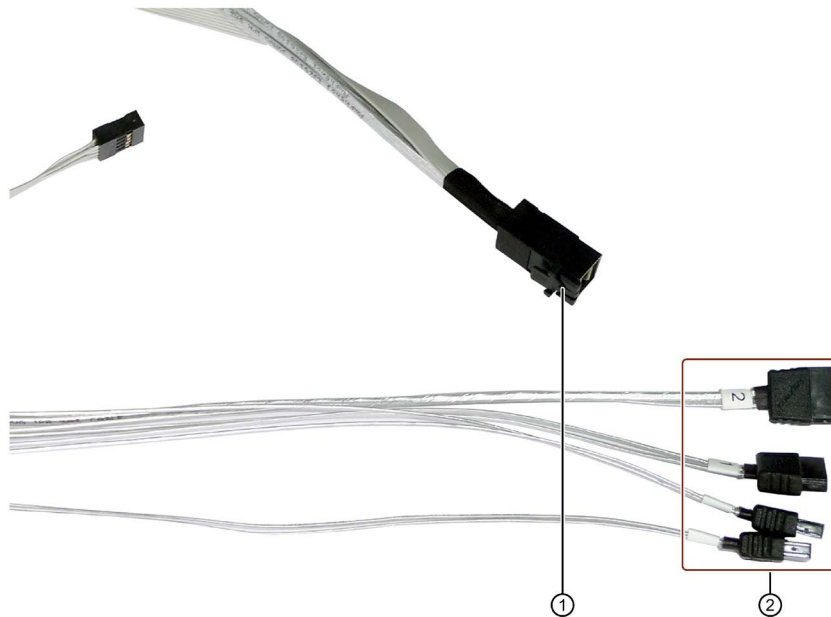

Observe the numbering of the connections ②.

Installing the RAID adapter card

For installation, follow the description in section "Installing and removing expansion cards (Page 73)".

Configuring the RAID adapter card

Note Management of the Hardware RAID system

When setting up the Hardware RAID system, set the write cache of the RAID controller as follows (see the additional documentation of Adaptec):

- Write Caching - Enable with Backup Unit
- create RAID via: Build/Verify

After replacement of the RAID adapter card, configure it in the BIOS setup as follows:

Note

The key combination <CTRL+A> is only effective in "Legacy" mode. If the "Boot Type" parameter is set to "UEFI Boot Type" in the "Boot" menu in the BIOS setup, the RAID hardware is configured by using the "Device Management" button in the BIOS selection menu.

1. Switch on the device.
2. During the boot phase, press the key combination <CTRL+A> when prompted to do so.

If the "Boot Type" parameter is set to "Dual Boot Type" in the "Boot" menu in the BIOS setup and an EFI boot medium is available, you must press the <ENTER> key after having pressed the <CTRL+A> within 1 second.

The system starts if you do not press the <ENTER> key in time.

3. Assign the parameters under "Controller Configuration" as follows:

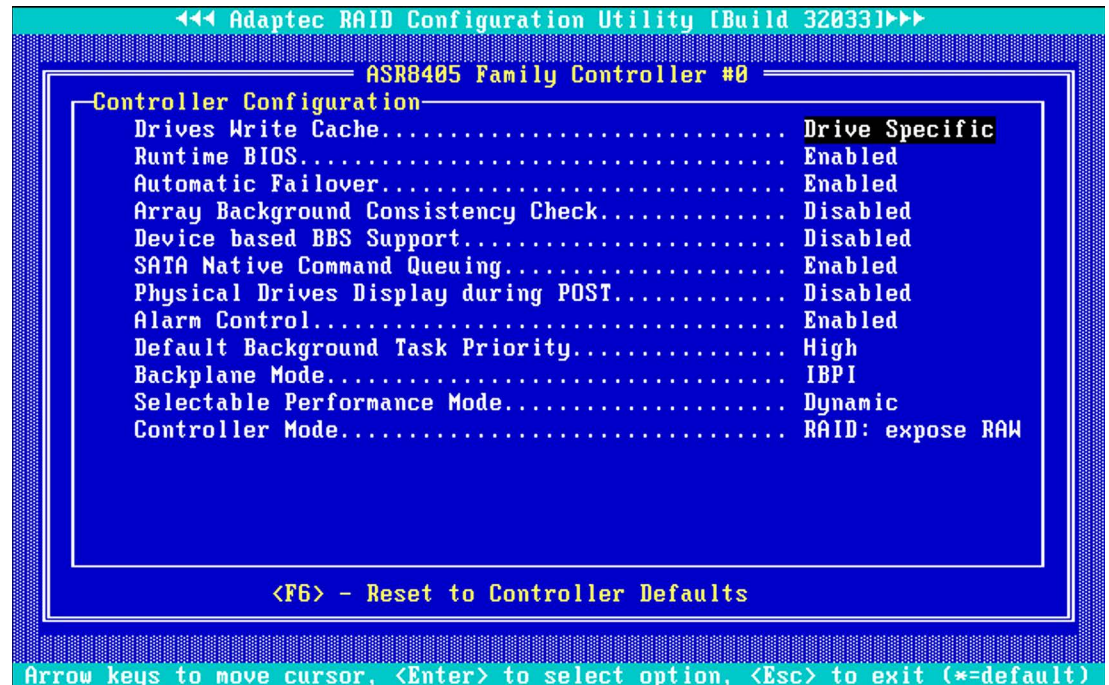

Note

The settings shown correspond to the default setting in the delivery state of the device.

Difference in the parameters compared to the default setting of the Hardware RAID adapter card after replacement:

- "Drives Write Cache = Disabled", which means the write cache of the hard disk is switched off.
 - "Alarm Control = Disabled", which means the acoustic alarm in case of a fault is switched off
-

6.4 Installing a second COM interface (optional)

Requirement

- The device is open; see section "Open the device. (Page 53)".
- Tx10 screwdriver

Procedure

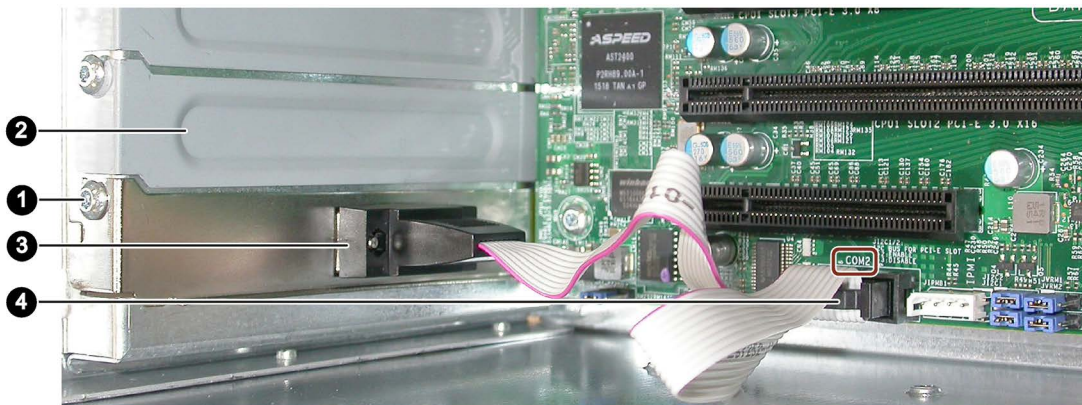

1. Remove the screw on slot 1.
2. Remove the associated slot bracket, similar to the figure ②.
3. Insert the slot bracket with the pin connector of the COM interface and screw it in place.
4. Insert the plug connector onto the marked location on the motherboard.

No other steps are needed for installing the COM interface.

Device maintenance and repair

7.1 Repair information

Carrying out repairs

Only qualified personnel are permitted to repair the device.

 WARNING
<p>Unauthorized opening and improper repairs on the device may result in substantial damage to equipment or endanger the user.</p> <ul style="list-style-type: none"> • Always disconnect the power plug before you open the device. • Only install system expansion devices designed for this device. If you install other expansion devices, you may damage the device or violate the safety requirements and regulations on RF suppression. Contact your technical support team or where you purchased your PC to find out which system expansion devices may be installed.

If you install or exchange system expansions and damage your device, the warranty becomes void.

 CAUTION
<p>Electrostatic sensitive devices (ESD)</p> <p>The device contains electronic components which are destroyed by electrostatic charges. This can result in malfunctions and damage to the machine or plant.</p> <p>Make sure you take precautionary measures even when you open the device, for example, when opening device doors, device covers or the enclosure cover. You can find more information in section "ESD guidelines".</p>

Limitation of liability

- All technical specifications and approvals for the device apply only if you use expansion components that have a valid CE marking.
- Observe the installation instructions for expansion components in the associated documentation.
- UL approval of the device only applies when the UL-approved components are used according to their "Conditions of Acceptability".
- We are not liable for functional limitations caused by the use of third-party devices or components.

Tools

You can make repairs on the device with the following tools:

- Tx10 screwdriver for all of the remaining screws
- Phillips screwdriver

7.2 Maintenance intervals

To maintain high system availability, we recommend the preventative replacement of those PC components that are subject to wear in accordance with the intervals for replacement indicated in the table below.

Component	Replacement interval
Filter pad	1 year or earlier depending on the degree of soiling
Device fan	3 years
Backup battery	5 years

7.3 Removing and installing hardware

7.3.1 Remove the fan cover

1. Open the front door until the marked lock releases the fan cover, see also section "Opening the front door (Page 41)".
2. Take hold of the recessed grip.
3. Open the fan cover in the direction of the arrow.



7.3.2 Replacing filters

The filter pad is located behind the fan cover.

Note

You may only use filters of the same type. Information about the original spare parts for SIMATIC PCs is available in the Internet at SIMATIC IPC after-sales information system (<http://www.siemens.com/asis>).

Filter pads are available as a pack of 10 under the article number A5E37019277.

Requirement

- The device is disconnected from the power supply; see section "Switching off the device (Page 39)".
- The front door is open; see section "Opening the front door (Page 41)".
- The fan cover has been removed; see section "Remove the fan cover (Page 82)".
- A filter pad from the pack of 10 A5E37019277

Procedure

1. Remove the filter pad from the fan cover.
2. Insert the new filter pad into the fan cover. It is inserted loosely in the fan cover. When you insert the filter pad, make sure it lies evenly in the fan cover.
3. Replace the fan cover.

Note

Use of the filter pad

We advise against using filter pads that have already been used. If you do want to refit a filter pad you have removed, however, take account of the direction in which the fan draws air into the device. Make absolutely certain that you do not fit the outer side of the filter pad on the inside. Generally, the outer side is clearly dirty after it has been in use for some time.

See also

Maintenance intervals (Page 82)

7.3.3 Replacing device fans

Requirement

- The device is fully disconnected from the line voltage, see section "Switching off the device (Page 39)".
- The device is open; see section "Open the device. (Page 53)".
- 1 fan, article number 6BK1700-6HA71-0AA0

Procedure

Removal

1. Detach the plug of the connecting cable of the fan from the motherboard.
2. Detach the protective grille from the device fan.
3. Lift the device fan in the marked keyhole and remove it towards the front.

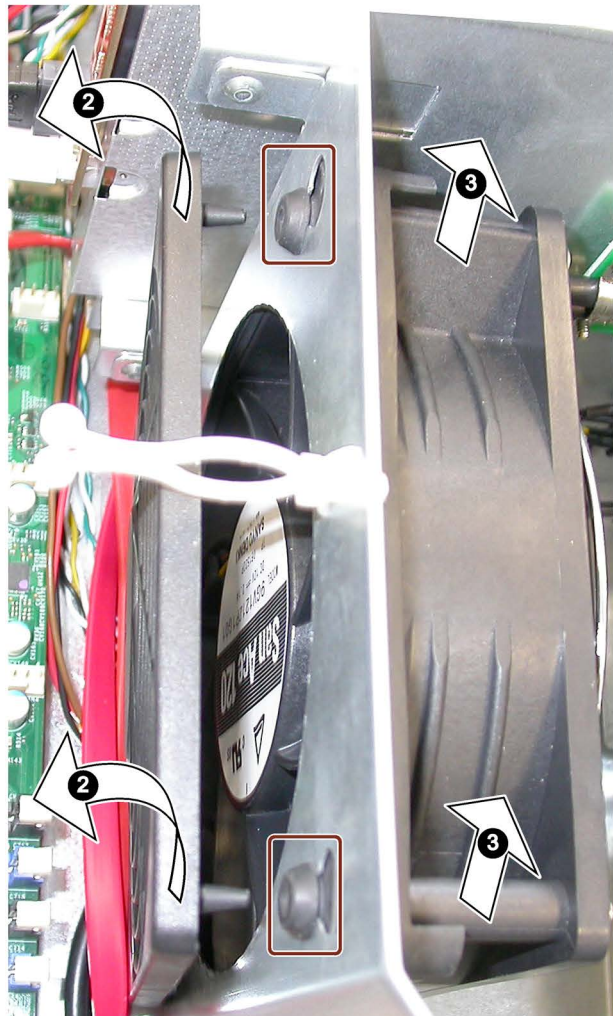
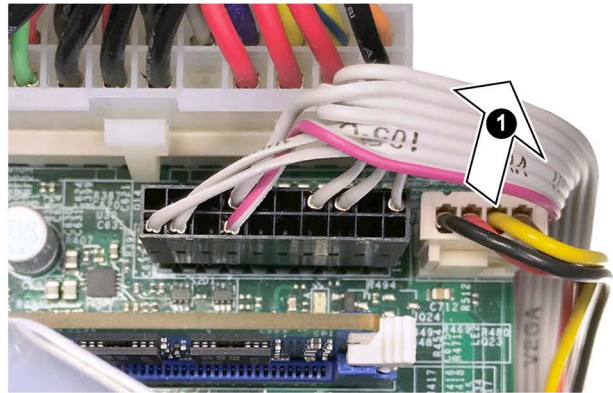

Installation

Note

Install only fans of the same type. Use the "FAN1" slot for the connecting cable of the fan. Ensure that the arrow on the device fan points toward the fan bracket. The device fan blows air into the enclosure.

To install the fan, follow the steps for removing it in reverse order.

See also

Maintenance intervals (Page 82)

7.3.4 Change the fan on drive cage type A

This fan is only installed in the removable tray (drive cage type A) for configurations with RAID and the hard disk type "Enterprise".

Requirement

- The device is fully disconnected from the line voltage, see section "Switching off the device (Page 39)".
- The device is open; see section "Open the device. (Page 53)".
- The adapter module for removable drive trays is removed, see section "Installing a 5.25" adapter module for removable trays (Page 58)".
- An original spare part, i.e. a fan of the same type.

Procedure

1. Detach the fan cable from the motherboard.
2. Press the upper and lower lock ① on the fan support and remove the fan support from the drive cage.

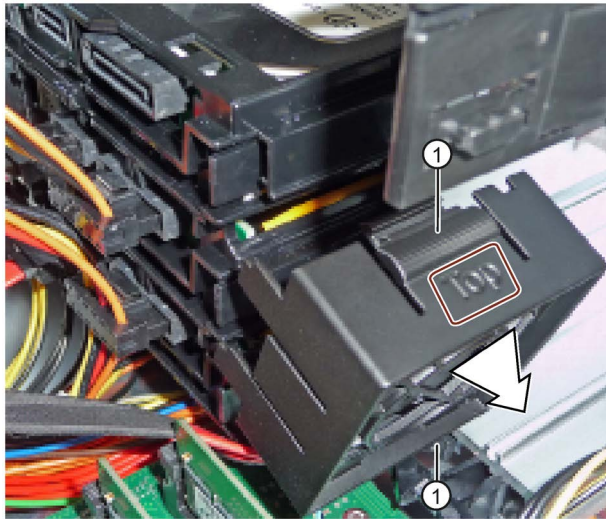

The fan holder is labeled as follows:

- At the top with "Top"
- At the bottom with arrows which indicate the direction of rotation and air flow of the fan.

3. Put down the fan support as shown.

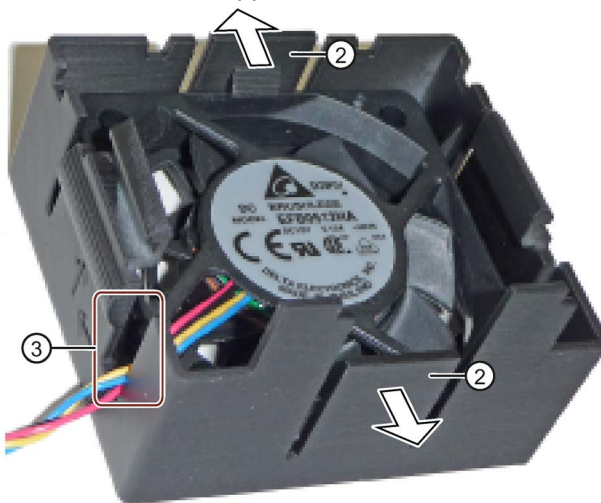

4. Bend the locking latches ② of the fan support slightly outwards and remove the fan from the fan support.
5. Place the new fan in the fan support as shown.
6. Guide the fan cable through the cable outlet ③.
7. Finally, snap the new fan completely into place in the locking latches ②.
8. Mount the fan support on the drive cage (see above).
9. Connect the fan cable to the motherboard.

See also

Maintenance intervals (Page 82)

7.3.5 Replacing the backup battery

The battery is used to back up the CMOS data for the BIOS setup and the real-time clock.

Note

Note the following points:

- Check the maintenance interval.. You can find additional information in the section "Maintenance intervals (Page 82)".
 - Replace the lithium battery only with an identical one or with a battery type recommended by the manufacturer.
-

Requirement

- For the current BIOS setup settings, see section "BIOS description (Page 99)".
- The device is fully disconnected from the line voltage, see section "Switching off the device (Page 39)".
- The device is open, see the section "Open the device. (Page 53)".
- All cables on the device are unplugged.
- 1 battery; for article numbers, see section "Maintenance"

Procedure

 CAUTION
Danger from short circuit Conductive materials cause a battery short-circuit or damage adjacent modules. <ul style="list-style-type: none">• Only use insulated materials as tools for the battery replacement.• Do not touch any adjacent modules.
NOTICE
Damage to the battery Grease residues from your hands damage the battery. <ul style="list-style-type: none">• Do not touch the battery with your hands.• Use suitable gloves, for example.

Note

The configuration data of the device may be deleted after battery replacement, depending on the BIOS setting. With BIOS setting "Profile: User", the configuration data of the device is retained; only the date and time must be set again.

1. Remove the battery from the socket at the marked location.
2. Insert the new battery as shown.
3. Press the new battery centered into the socket applying slight pressure. Ensure that the battery is securely seated.
4. Dispose of the old battery properly.

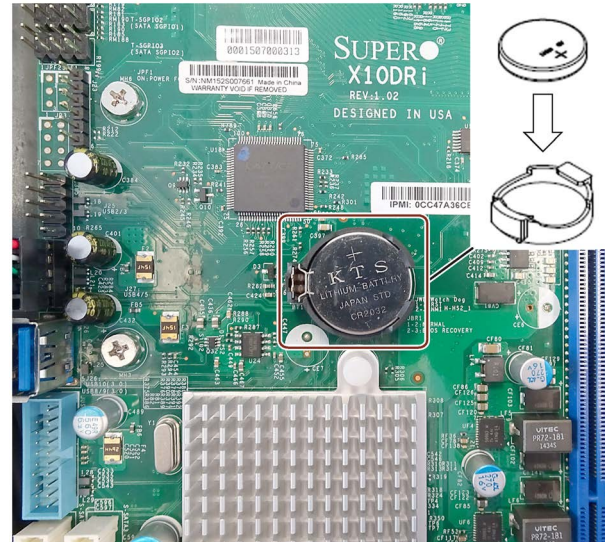

Further procedure

- Connect all cables.
- Close the device as specified in section "Open the device. (Page 53)".
- Set the BIOS setup.

The configuration data of the device may be deleted after a battery replacement depending on the BIOS setup setting.

7.3.6 Replacing the redundant power supply module

If a fault or an error has been reported for the redundant power supply, the LED of the defective module lights up, see section "Power indicators, redundant power supply (Page 17)". The device also works with the second, non-defective module.

Note

However, to ensure the availability of your system through the redundant power supply, replace the defective power supply module with a functioning new module as soon as possible.

- You can continue to operate the device until you can shut it down properly.
- The replacement of one of the two modules of the redundant power supply can be performed, however, without shutting down the device.

Requirement

- The power supply lines are connected, see section "Connecting a redundant power supply (Page 35)"

Procedure

Removal

1. Use the LEDs to determine which module is defective, e.g. the LED ④ lights red.
The LED ① can also flash red because there is a warning, e.g. overload.
2. Alternatively, shut down the device.
Disconnect the power plug ② from the power supply module to be replaced.
3. Acknowledge the warning signal on the LED ④.
4. Tilt the handle ⑥ forward.
5. Unlock the power supply module at the pin ③ and pull the module ⑤ straight forward out of the frame by the handle ⑥.
6. Slide the new power supply module into the frame all the way to the rear until it clicks into place.
7. Reconnect the power plug ②.
Alternatively, restart the device.

Both LEDs ① and ④ light in green again.

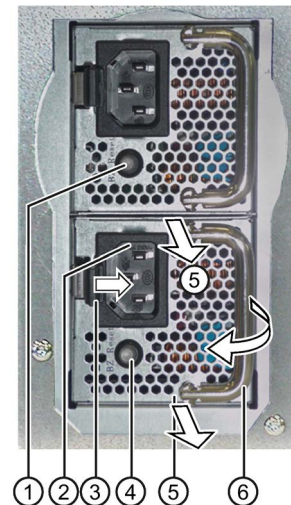

7.3.7 Replacing the processor

Requirement

- The device is opened.
- A suitable processor

Only an approved processor is permitted to be installed on the motherboard of the device. If the processor type is changed, the BIOS must be updated so that the suitable microcode is loaded. Information about original spare parts for SIMATIC IPCs is available on the Internet at:

- Contacts (<http://www.siemens.com/automation/partner>)
- SIMATIC IPC after-sales information system (<http://www.siemens.com/asis>)

Procedure

1. Remove the screws on the CPU heat sink.
2. Remove the heat sink.
3. Release the lever ② of the processor bay and tilt it all the way back. The bay releases the processor (figure similar).

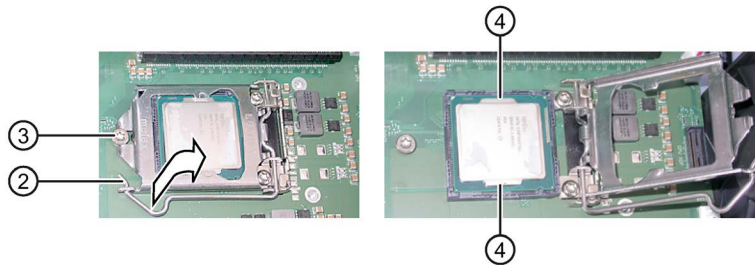

4. Remove the processor by grabbing the rails on the side ④. Do not touch the processor and its connections in the process (see Technical Specifications, chapter "ESD guidelines").
5. Install the new processor on the socket, as shown in the figure.
When you insert the processor, make sure the coding on the processor and on the socket match.
6. Tilt the lever ② to the front again. Make sure that the bay covers the screw ③.
7. Press the lever all the way down and lock it again.

NOTICE

Damage to the processor

The locking mechanism may be stuck. The locking mechanism is damaged while being pressed down. The processor is not correctly locked in place by the bay. The result may be malfunctions.

- Do not use excessive force.
- Tilt the lever back again and try again.

8. Place the heat sink back on the processor and tighten the screws.

Processor type and clock frequency

When a processor is replaced, perform a BIOS update. The microcode matching the processor is loaded in the process.

Note

Damage to the processor due to high clock frequency

If the installed processor is operated with a higher clock frequency than permitted, it can be destroyed or cause loss of data.

Operate the processor only at a clock frequency that is equal to or less than the permitted clock frequency.

7.4 Installing the software

This section contains information on installing and restoring the operating system.

Depending on the configuration, the device has no operating system or one of the following operating systems:

- Windows 10, pre-installed
- Windows Server 2016, only license and drivers, not pre-installed

You can find additional information on the pre-installed operating system on the Internet under:

- Windows 10 on the supplied USB stick
(<https://support.industry.siemens.com/cs/ww/en/view/109749498>)

7.4.1 Back-up authorization or license key

Procedure

- Check whether you can back-up your authorization or license key from the drive and perform this procedure if possible.
- If backup is not possible, please contact Customer Support. There you can obtain information necessary for corresponding software authorization.

NOTICE
<p>Risk of data loss</p> <p>If "Restore system partition only" is set all data on drive C: (system partition) will be deleted. All data, user settings and all authorizations or license keys on drive C: are lost! All data on drive C: will be completely deleted, reformatted and overwritten with the original factory software.</p> <p>If "Restore entire drive" is set ALL data, user settings, authorizations or license keys will be lost on the entire drive.</p>

7.4.2 Restoring the factory settings of the operating system and partitions (Restore)

Using the Restore function, you can restore your device to the delivery state after damage, for example.

The Restore function restores the volume partitions, the operating system with installed device drivers, and the SIEMENS software products. Before performing the Restore function, observe the information in section "Back-up authorization or license key (Page 91)".

Setting Boot mode

Note

Boot mode in the delivery state

We recommend that you restore the device to the boot mode in which it was delivered.

You can restore the device in the following two boot modes:

UEFI mode (GPT volume):

To support new features, such as TPM 2.0 and volumes larger than 2 TB, the operating system must be restored in the way that it boots in UEFI mode.

1. Boot the supplied USB stick in UEFI mode.
2. The device is then set up with a GPT volume and boots in UEFI mode.

Legacy mode (MBR volume):

To support older extensions and functions, such as older PCI(e) cards and older software products, the operating system must be restored to boot in Legacy mode.

1. Boot the supplied USB stick in Legacy mode.
2. The device is then set up with an MBR volume and boots in legacy mode.

Notes on restoring

- If the data of partition D: (Data) should be retained during the restore, the device must be partitioned as in the delivery state.
- In boot mode, the device is restored to the delivery state.

Procedure

Note

The firmware settings might have to be changed in order for the device to boot from the provided USB stick.

NOTICE**Risk of data loss**

Files, user settings as well as existing authorizations and license keys are lost when a restore is performed.

Back up your data before restoring.

1. Insert the provided USB stick into the device.
2. Restart the device.
3. Boot with the provided USB stick in the Boot mode you have set beforehand.
4. In the Windows® Boot Manager, select the option "Restore Microsoft Windows ..." and confirm the selection.

The Restore program from Siemens starts after a few seconds.

5. Follow the instructions on the screen.

Note the following information.

Selecting the partitions to be restored

Option: "Restore complete system disk"

Use this option if you want to restore the complete factory settings of the device, including C partitions: (System) and D: (Data).

Option: "Restore existing system partition only"

Use this option if you are want to restore only the C: (System) and the boot functionality. The partition D: (Data) and all data stored there is retained.

7.4.3 Updating the operating system

Windows

The latest updates for the Windows operating system are available on the Internet at Microsoft (<http://www.microsoft.com/en-us>) and on the device in the Start menu "Start > All Programs > Windows Update > Check for updates".

Note

Before you install new drivers or operating system updates for Windows MUI versions, configure the regional menu and dialog settings and the default English (US) language.

Other operating systems

Contact the corresponding manufacturer.

7.4.4 Installing drivers and software

With the Windows 10 operating system, all drivers are installed in the delivery state. You can obtain more detailed information from the manufacturer, see section "Motherboard (Page 108)".

No drivers are installed for the Windows Server 2016 operating system. The drivers must be installed later, see section "Restoring the factory settings of the operating system and partitions (Restore) (Page 92)".

7.4.5 Installing Windows (Recovery)

The recovery function only installs the operating system on your device. In contrast to the restore function, no device drivers and no SIEMENS software products are installed by the recovery function.

Note

Specific information on using the Windows operating systems is available on the Internet:

- Microsoft Technet Windows (<http://technet.microsoft.com/windows>)
- Microsoft Technet Windows Server (<http://technet.microsoft.com/windowsserver>)

The listed manuals are not included in the scope of delivery.

Setting Boot mode

Note

Boot mode in the delivery state

We recommend that you install the operating system in the Boot mode that was set in the delivery state.

You can install the operating system in the following two boot modes:

UEFI mode (GPT volume):

To support new features, such as TPM 2.0 and volumes larger than 2 TB, the operating system must be installed in the way that it boots in UEFI mode.

For this purpose, the provided USB stick must also be booted in UEFI mode.

The operating system is then set up with a GPT volume and boots in UEFI mode.

Legacy mode (MBR volume):

To support older extensions and functions, such as older PCI(e) cards and older software products, the operating system must be restored to boot in Legacy mode.

For this purpose, the provided USB stick must also be booted in Legacy mode.

The operating system is then set up with an MBR volume and boots in Legacy mode.

Procedure

Note

The firmware settings might have to be changed in order for the device to boot from the provided USB stick.

You can find additional information on this in the description of the firmware/BIOS for the device.

NOTICE
Risk of data loss Files, user settings as well as existing authorizations and license keys are lost when the operating system is installed! <ul style="list-style-type: none">• Back up your data before installing the operating system.

1. Insert the provided USB stick into the device.
2. Restart the device.
3. Boot with the provided USB stick in the Boot mode you have set beforehand.
4. In the Windows Boot Manager, select the "Recovery Microsoft Windows ..." option and confirm the selection.

The Windows installer starts after a few seconds.

5. Follow the instructions on the screen.

Note the following information.

"Install Windows" installation program

The language of the installation program and the operating system is preset to English. You can change the language of the operating system after the installation. Information on this topic is available in the section "Setting up the language selection using the Multilanguage User Interface (MUI)".

Setting up partitions and integrating storage controllers unknown to the operating system

You can set up partitions during the installation process and integrate storage controllers that are unknown to the operating system. To do so, select "Custom (advanced)" when prompted for the installation type in the "Install Windows" installation program.

The following example illustrations show the available dialog windows.

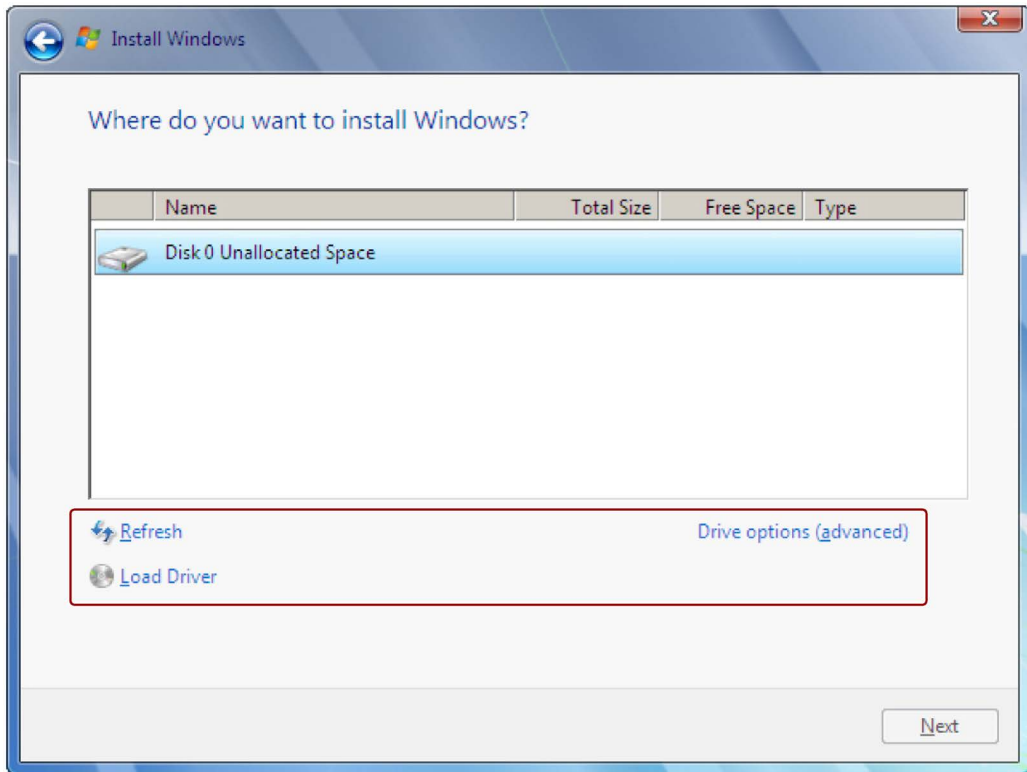

Refresh	Updating
Load Driver	Integration of controller drivers unknown to the operating system and required for installation. Please read the information under "Information for systems with RAID or AHCI controller" at the end of this section.
Drive options (advanced)	Display of additional functions that you can use to set up the data storage media, see the following figure.

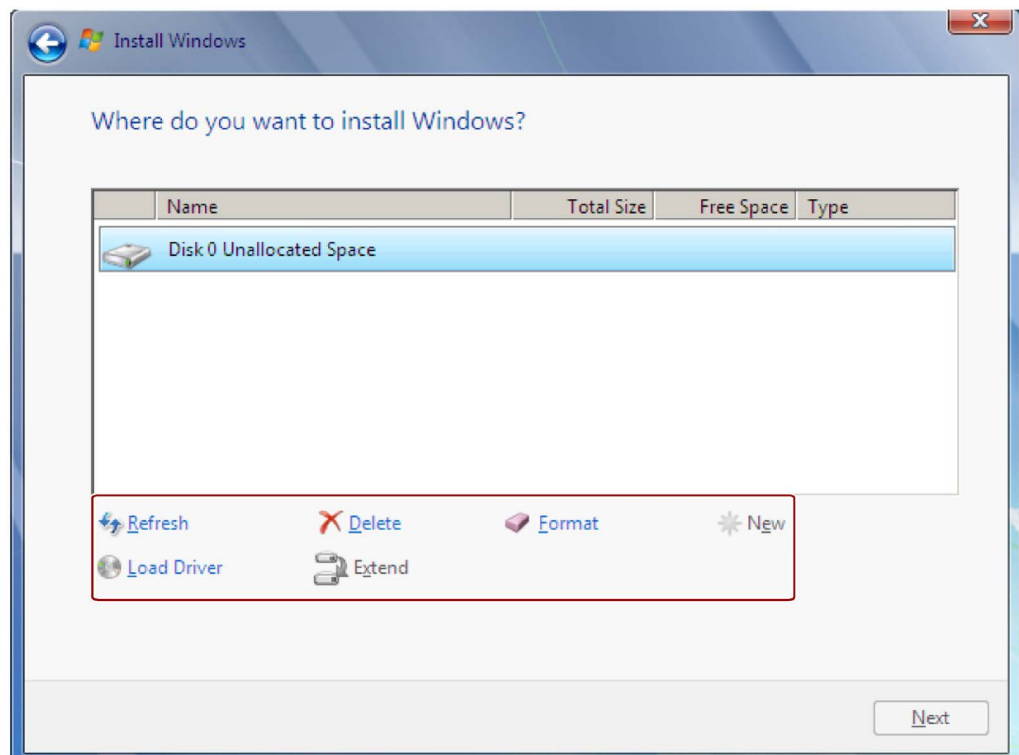

Refresh	Updating
Load Driver	Integration of controller drivers unknown to the operating system and required for installation. Please read the information under "Information for systems with RAID or AHCI controller" at the end of this section.
Delete	Deleting a partition
Extend	Changing the partition size
Format	Formatting a partition
New	Creating new partitions
	Identification for error messages, for example, if the data medium was not formatted in the required "NTFS" format.

Note

If you want to install the operating system on a data medium connected to a storage controller unknown to the operating system, you have to integrate the driver of the storage controller. Integrate this driver before you partition the data medium and before you install the operating system. You will find more information on integrating the storage controller under "Information for systems with RAID or AHCI controller" at the end of this section.

1. Make sure that the partition on which you want to install the operating system is large enough and is set up with a NTFS file system.
The recommended minimum size of this partition varies, depending on the operating system, how much RAM you have available and how much additional software you want to use. Information on how the data medium is partitioned in its factory state is available in the tables below.
2. Select the partition on which you want to install the operating system.
3. Click "Next".
Installation is started. The Windows operating system is installed on the data medium.

Information for systems with RAID or AHCI controller

Data carrier controllers unknown to the operating system must be made known to the operating system prior to installation in the "Install Windows" installation program.

Requirement

You have copied the relevant controller driver to a USB stick.

Procedure

1. Connect the USB stick with the controller driver to the device.
2. Start the "Install Windows" installation program as described above.
3. Select "Load Drivers" in the Windows installation window.
4. Select the respective driver on the USB stick.

7.4.6 Installing Hardware RAID controller software

Note

Observe the "General information on commissioning (Page 37)" in section "Commissioning the device". Additional information is available in section "Installing drivers and software (Page 94)".

7.5 BIOS description

BIOS Setup program

The BIOS Setup program, or BIOS Setup for short, is located, together with the setup parameters, in a FLASH block on the motherboard. You change the setup parameters of the device in the BIOS Setup. Examples: System time, hard disks or boot order.

Press during booting to open the BIOS Setup.

Changing the device configuration

Your device configuration is preset for operating with the included software. You should only change the default setup parameters if you have made technical changes to your device, or if a fault occurs when the device is switched on.

Note

Documentation

You can find the BIOS description from the manufacturer at Supermicro (<https://www.supermicro.com/products/motherboard/xeon/c600/x10dri.cfm>)

7.6 IPMI Setup

The IPMI Setup is documented in detail by the manufacturer: IPMI (<https://www.supermicro.com/solutions/IPMI.cfm>).

The procedure is briefly outlined below.

Procedure

1. Set up the dynamic address assignment via DHCP
Alternatively, assign a fixed IP address, e.g. "192.168.10.253".
2. Establish a connection to IPMIView, see section "Monitoring functions (Page 51)".
3. Set up the remote control via iKVM, also with IPMIView.

7.7 Recycling and disposal

Legal statement regarding disposal of old devices



European law forbids disposal of electrical and electronic devices in household waste.

- Do **not** dispose the device or its replacement and expansion components in household waste and **not** at public waste disposal points.
- For environmentally compatible recycling and disposal of the device and its components, contact a certified disposal company for electronic waste or your Siemens contact (product return (<https://support.industry.siemens.com/cs/ww/en/view/109479891>)).

Observe the following:

- Country-specific regulations
- Local legal requirements
- Special information regarding the German Battery Ordinance

Technical specifications

8.1 General specifications

General specifications

Order number	6BK1800-1xxxx-xxxx (for details, refer to the ordering documentation)
Dimensions	430 × 177 × 572 (W × H × D in mm). Detailed dimensional specifications can be found in section "Dimensional drawing of the device (Page 109)".
Weight	Max. 25 kg
Supply voltage (V _N)	100 ... 240 V AC, (-10 %, +10 %), wide-range
Input current	Single power supply: 13 A (100 V), 7 A (240 V) Fuse, internal: 15 A, type "time-lag"
	Redundant power supply: 10 A (100 V), 5 A (240 V) Fuse, internal: 12 A, type "time-lag"
Inrush current	Max. 125 A (115 V AC), max. 65 A (230 V AC)
Inrush current, redundant	Max. 80 A (115 V AC), max. 40 A (230 V AC)
Line voltage frequency	50 to 60 Hz (min. 47 Hz to max. 63 Hz, sinusoidal)
Power consumption	AC power supply: Max. 860 W at 85% efficiency Redundant AC power supply: Max. 700 W at 85% efficiency
Noise emission	< 48 dB(A) at 23°C IDLE < 51 dB(A) at 23°C full load according to DIN EN ISO 7779
Degree of protection	<ul style="list-style-type: none"> • IP 30 (front) with closed front door • IP 20 on the rear according to EN 60529
Dust protection	With closed front door Filter class G2 EN 779, 99% of particles > 0.5 mm are filtered

Note

Dimensioning of fuses in higher-level plant circuits

A fuse with a fuse rating according to the "Input current" row of the previous table is integrated in the power supply unit of the IPC. Pulse currents during startup are also taken into consideration due to the "time-lag" fuse type. In the case of a fault, this fuse ensures the correct separation of the device from the power supply.

We recommend dimensioning the fuse of the higher-level power supply circuit with at least the internal fuse rating of the IPC plus the power requirements of the other devices supplied via this circuit. The tripping characteristic of the higher-level fuse must hereby take into consideration the starting currents of the IPC and those of the other devices.

Safety

Protection class	Protection class I according to IEC 61140
Degree of pollution	Device is designed for environments with pollution degree 2
Transient overvoltages	Device is designed for connection to supply with overvoltage category II (transient overvoltages up to 2500 V)
Safety regulations	<ul style="list-style-type: none"> • IEC 61010-2-201 • EN 61010-2-201 • UL 61010-2-201 • CSA C22.2 No 61010-2-201

Electromagnetic compatibility (EMC)

Interference emission	EN 61000-6-3, FCC Class A EN 61000-6-4; CISPR 22 / EN 55022 Class A EN 61000-3-2 class D, EN 61000-3-3
Noise immunity: Conducted disturbance variables on supply lines	± 2 kV, according to IEC 61000-4-4, burst ± 2 kV, according to IEC 61000-4-5, surge sym. ± 2 kV, according to IEC 61000-4-5, surge asym.
Noise immunity on signal lines	± 2 kV; according to IEC 61000-4-4; burst; length < 30 m ± 2 kV; according to IEC 61000-4-4; burst; length > 30 m ± 2 kV; according to IEC 61000-4-5; surge; length > 30 m
Immunity to discharge of static electricity	± 4 kV contact discharge in accordance with IEC 61000-4-2 ± 8 kV air discharge in accordance with IEC 61000-4-2
Immunity to RF interference	<ul style="list-style-type: none"> • 10 V/m, 80...1000 MHz and 1.4...2 GHz, 80% AM 1 kHz, according to IEC 61000-4-3 • 3 V/m 2...6 GHz, 80% AM 1 kHz, according to IEC 61000-4-3 • 10 V, 15 KHz...80 MHz, 80% AM 1 kHz, according to IEC 61000-4-6
Magnetic field	100 A/m, 50 Hz/60 Hz, according to IEC 61000-4-8

Climatic ambient conditions

Temperature	Tested in accordance with IEC 60068-2-2, IEC 60068-2-1, IEC 60068-2-14
During operation	0 °C ... +50° C ¹ in basic configuration and with drive cage type B 0 °C ... +40 °C in maximum configuration or with drive cage type A For the definitions of basic and maximum configuration, see section "Configuration variants (Page 72)". ¹ Also observe the installation options and temperature specifications in section "Overview (Page 54)".
Storage/transport Gradient	-20 °C ... +60 °C ≤ 20°K/h, no condensation
Relative humidity	Tested in accordance with IEC 60068-2-78, IEC 60068-2-30
During operation Gradient	Permitted range: 0 to 31 °C: 5-80%; decreasing linearly to 5-23% at 50° C, no condensation ≤ 10°K/h, no condensation
Storage/transportation Gradient	5% ... 95% at 25 °C to 55 °C, no condensation ≤ 20 K/h, no condensation
Atmospheric pressure	
During operation	1080 to 689 hPa, corresponds to an altitude of -1000 to 3000 m
Storage/transport	1080 to 660 hPa, corresponds to an altitude of -1000 to 3500 m

Mechanical ambient conditions

Vibration	Tested according to IEC 60068-2-6, 10 cycles
Storage/transport	5 ... 8.51 Hz: Amplitude 3.5 mm 8.51 ... 500 Hz: Acceleration 9.8 m/s ² = 1 g
Operation	10 ... 58 Hz: Amplitude 0.0375 mm 58 to 200 Hz: Acceleration 4.9 m/s ²
Resistance to shock	Tested in accordance with IEC 60068-2-27, IEC 60068-2-29
Storage/transport	Half-sine: Acceleration 250 m/s ² , duration 6 ms, 1000 shocks per axis
Operation	Half-sine: Acceleration 50 m/s ² , duration 30 ms
Special features	
Quality assurance	In accordance with ISO 9001

Motherboard

You can obtain more detailed information from the manufacturer, see section "Motherboard (Page 108)".

8.1 General specifications

Drives

Hard disks	<ul style="list-style-type: none"> • 2.5", internal • 3.5", internal (optional)
Solid State Drive	<ul style="list-style-type: none"> • 2.5" SATA, internal

RAID

SAS/SATA hardware RAID controller (optional)	<ul style="list-style-type: none"> • SAS/SATA RAID module PCIe 3.0 x8, RAID 1, 5 • Type: Adaptec 8405 (independent processor, 1024 MB DDR3 cache)
<ul style="list-style-type: none"> • Parameter 	<ul style="list-style-type: none"> • 1 × Mini SAS/SATA HD adapter (SFF-8643 for 4 drives) • Maximum theoretical controller data rate 12 Gbps per port • Support of up to 256 SAS/SATA devices via SAS expander • Native 4K sector support with corresponding SAS/SATA disks • Supported RAID level: 0, 1, 1E, 5, 6, 10, 50, 60; Hybrid RAID 1 & 10 • S.M.A.R.T. support • "Secure Boot" support for the UEFI BIOS
SAS/SATA hardware RAID controller (optional)	<ul style="list-style-type: none"> • SAS/SATA RAID module PCIe 3.0 x8, RAID 1, 5 • Type: Adaptec 8805 (independent processor, 1024 MB DDR3 cache)
<ul style="list-style-type: none"> • Parameter 	<ul style="list-style-type: none"> • 2 × Mini SAS/SATA HD adapter (SFF-8643 for 8 drives) • Maximum theoretical controller data rate 12 Gbps per port • Support of up to 256 SAS/SATA devices via SAS expander • Native 4K sector support with corresponding SAS/SATA disks • Supported RAID level: 0, 1, 1E, 5, 6, 10, 50, 60; Hybrid RAID 1 & 10 • S.M.A.R.T. support • "Secure Boot" support for the UEFI BIOS
Software RAID	<ul style="list-style-type: none"> • Supported RAID level: 0, 1, 5, 10

Graphics

Graphics controller	Onboard Aspeed AST2400
CPU	400 MHz ARM926EJ 16 KB/16 KB Cache
Graphics memory	800 Mbps DDR3/DDR2 SDRAM 16 Bit, 512 MB ECC (optional)
VGA	PCIe VGA/2D Controller 1920 × 1200@60Hz 32bpp

Interfaces

COM		Serial interface (V.24), 9-pin sub D connector
VGA		Connection of an analog monitor
USB	Rear of the device	<ul style="list-style-type: none"> • 2 × USB 3.0 5V / 2 × 900 mA / high current • 2 × USB 2.0 5V / 2 × 500 mA / high current
	Front panel	<ul style="list-style-type: none"> • 2 × USB 3.0 5V / 2 × 900 mA / high current
Ethernet		<ul style="list-style-type: none"> • 2 × Ethernet interface (RJ45), Wake on LAN, Remote Boot and Teaming are supported. • 1 × dedicated IPMI interface (RJ45) 10/100/1000 Mbps, electrically isolated *

* Electrical isolation within the safety extra-low voltage circuit (SELV)

8.2 Current and power requirements

Base system

The following table shows the power requirements of different system components. The current values associated with the different voltages are given in the unit "Ampere" (A).

Component	Voltage		
	+3.3 V	+5 V	+12 V
Motherboard			
• X10DRI: Remainder	1	0.6	0.3
• Chipset: Intel® C612 (PCH)	0	5.7	0
• Gigabit controller: Intel® i210	0.5	0	0
CPUs Intel® Xeon® Processor E5-2658 V4	0	0	17.5
CPUs Intel® Xeon® Processor E5-2643 V4	0	0	22.5
CPUs Intel® Xeon® Processor E5-2640 V4	0	0	15
CPUs Intel® Xeon® Processor E5-2620 V4	0	0	14.16
CPUs Intel® Xeon® Processor E5-2609 V4	0	0	14.16
4 × 8 GB RAM DDR4	0	0	0.68
4 × 32 GB RAM DDR4	0	0	1.28
1 × graphics card NVIDIA QUADRO P5000	0	0	15
1 × graphics card NVIDIA QUADRO P4000	0	0	8.75
1 × graphics card NVIDIA QUADRO P1000	0	0	3.75
1 × graphics card NVIDIA QUADRO P400	0	0	2.5
1 × 2.5" SSD SATA (typical)	0	0.9	0
1 × 2.5" HDD SAS (typical)	0	0.59	0.37
1 × 3.5" HDD SATA (typical)	0	0.5	0.7

8.3 Power supply (AC)

Component	Voltage		
	+3.3 V	+5 V	+12 V
Device fan	0	0	2.1
Processor fan	0	0	2.7
Individual currents of single power supply, max. permissible	25 ²	25 ²	60 ²
Individual currents of redundant power supply, max. permissible	20 ²	20 ²	58 ²
Total power, permissible	860 W ³		
Efficiency of the power supply ¹	Approx. 80% (230 VAC), approx. 80% (120 VAC)		

- ¹ Depends on the selected device configuration
- ² Observe the maximum permissible values for the total power of the voltages (see next section)
- ³ Lower permissible total power with redundant power supply

8.3 Power supply (AC)

Output voltage

Voltage	Max. current	Voltage stability
+12 V	60 A	+/-5%
-12 V	0.8 A	+/-5%
+5 V	25 A ¹	+/-5%
+3.3 V	25 A ¹	+/-5%
+5 V aux	3.5 A	+/-5%

- ¹ The total current consumption of the +5 V and + 3.3 V voltage must not exceed 40 A.

Note

Operation at an uninterruptible power supply (UPS)

The power supply contains an active PFC (Power Factor Correction) circuit to conform to the EMC guidelines.

Uninterruptible AC power systems (UPS) must supply a sinusoidal output voltage in the normal and buffered mode when used with SIMATIC PCs with an active PFC.

UPS characteristics are described and classified in the standards EN 50091-3 and IEC 62040-3. Devices with sinusoidal output voltage in normal and buffered mode are identified with the classification "VFI-SS-...." or "VI-SS-....".

8.4 AC power supply, redundant

Output voltage

Voltage	Max. current	Voltage stability
+ 12 V	58.3 A	+/-5%
- 12 V	0.5 A	+/- 10%
+ 5 V	20 A ¹	+/-5%
+ 3.3 V	20 A ¹	+/-5%
+ 5 Vaux	3.0 A	+/-5%

¹ The accumulated power of the +5 V and + 3.3 V supply may not exceed 130 W.

The input current is:

100 V AC: 10 A

240 V AC: 5 A

The maximum inrush current is for:

115 V AC: 80 A

230 V AC: 40 A

Note

Operation at an uninterruptible power supply (UPS)

The power supply contains an active PFC (Power Factor Correction) circuit to conform to the EMC guidelines. Uninterruptible AC power systems (UPS) must supply a sinusoidal output voltage in the normal and buffered mode when used with SIMATIC PCs with an active PFC. UPS characteristics are described and classified in the standards EN 50091-3 and IEC 62040-3. Devices with sinusoidal output voltage in the normal and buffered mode are identified with the classification "VFI-SS-...." or "VI-SS-....".

8.5 Motherboard

You can find more detailed information from the manufacturer at "Supermicro (<https://www.supermicro.com/products/motherboard/xeon/c600/x10dri.cfm>)".

Specifically, the manual for motherboard:
X10DRi (https://www.supermicro.com/manuals/motherboard/C606_602/MNL-1491.pdf)

Dimension drawings

9.1 Dimensional drawing of the device

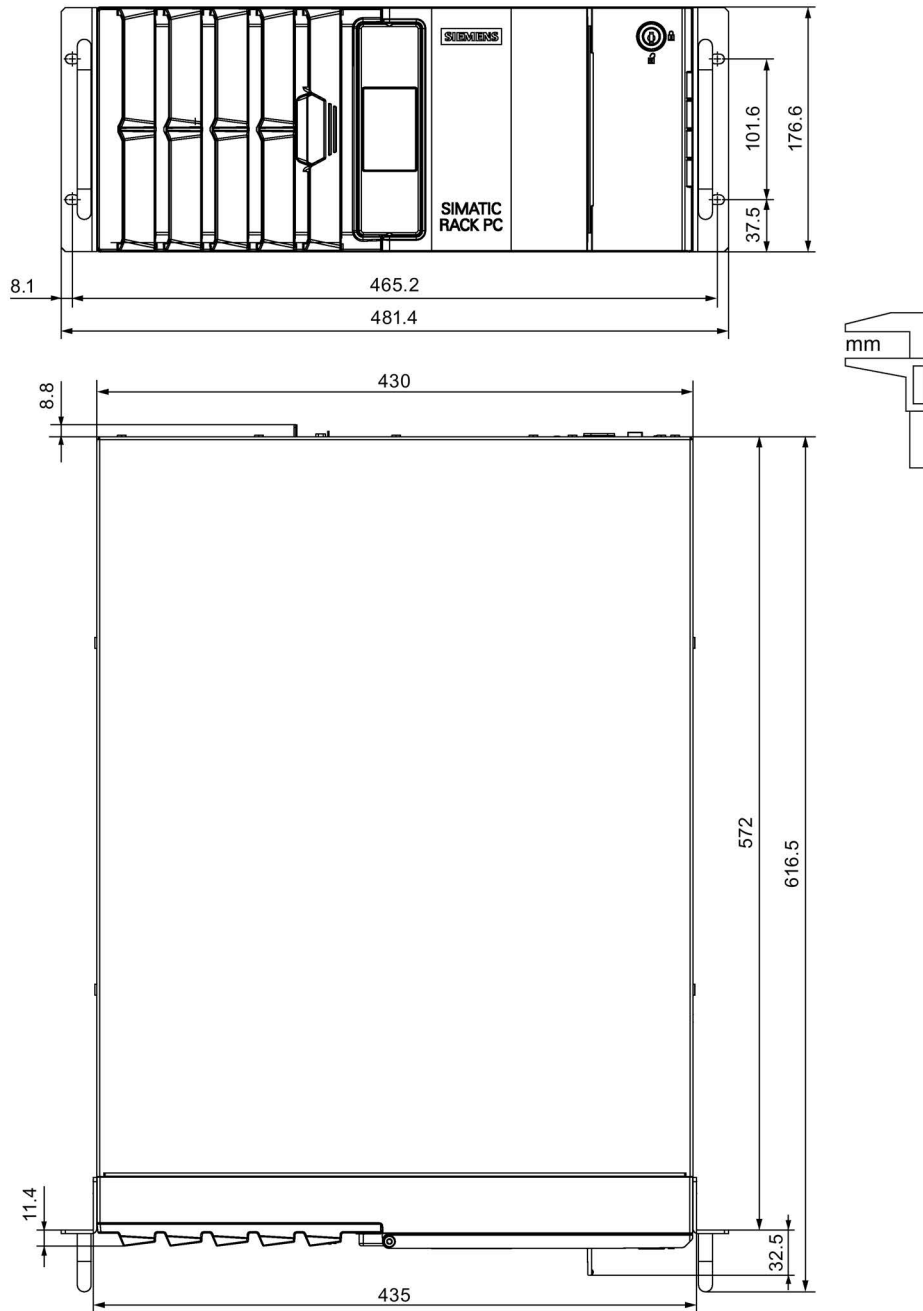

9.2 Dimension drawing for telescope rails

The figure below shows the dimensions of the threaded holes for the telescopic rails. You can find additional information in the section "Mounting the device (Page 32)".

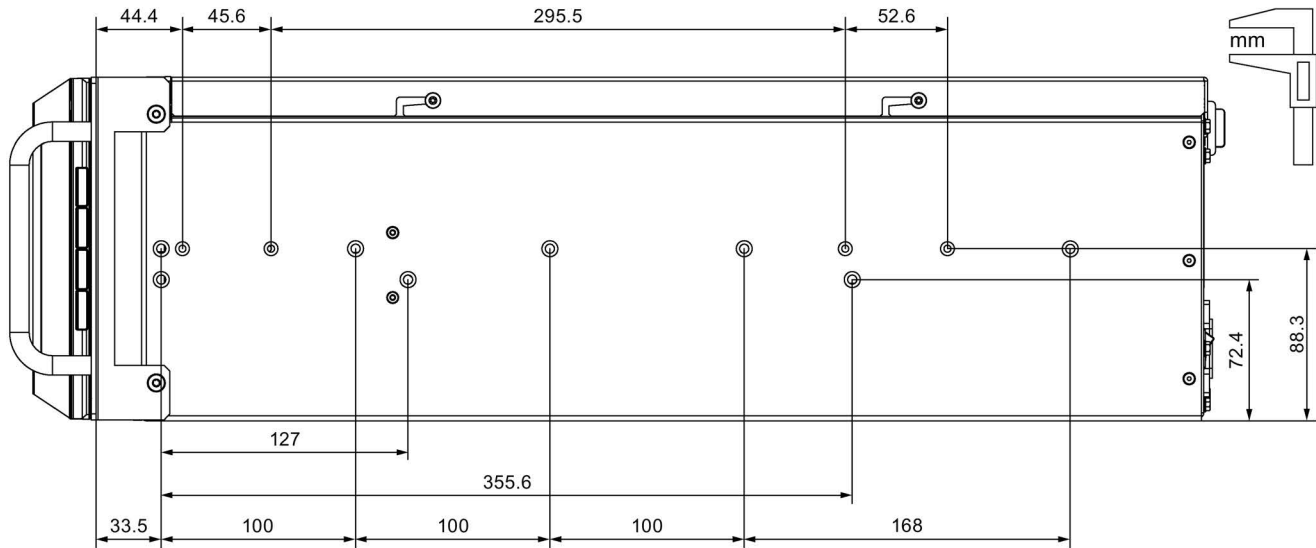

9.3 Dimension drawing of the expansion cards

The following dimension drawing shows the main dimensions of the PCI Express expansion card without slot bracket.

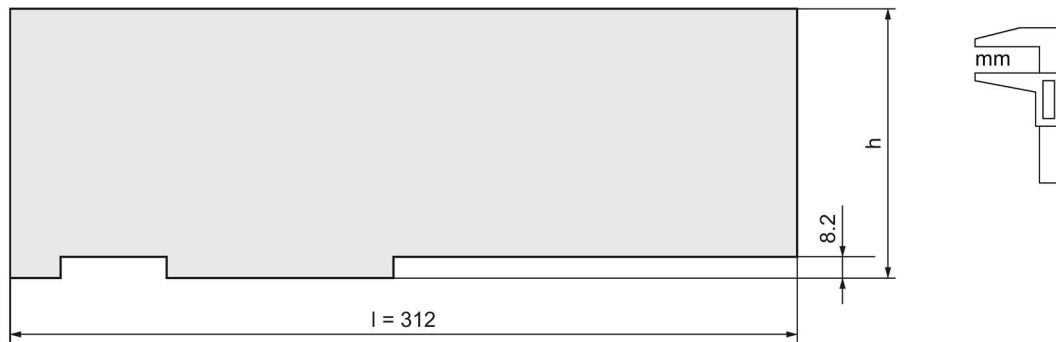

Height (h), Length (l), Depth (d)

	PCI	PCIe	Example PCIe: Graphics card NVIDIA TESLA
h	106.68 mm / 4.2"	111.15 mm / 4.38"	110 mm
l	312 mm / 12.28"		265 mm
d	Single Slot		Dual Slot: The card requires two free expansion slots

Standards and approvals

Note

Approvals on the rating plate

The following overview provides information on possible approvals.
Only the approvals printed on the rating plate apply to the device.



The device meets the general and safety-related requirements of the following directives and conforms to the harmonized European standards (EN) published in the official gazettes of the European Union:

- 2014/30/EU "Electromagnetic Compatibility Directive" (EMC Directive)

The device is designed for the following areas of application corresponding to the CE marking:

Area of application	Requirement for	
	Interference emission	Immunity to interference
Industry	EN 61000-6-4	EN 61000-6-2
Residential and commercial areas and small businesses	EN 61000-6-3	EN 61000-6-1

The devices are compliant with EN 61000-3-2 (harmonic currents) and EN 61000-3-3 (voltage fluctuations and flicker).

- 2014/35/EU "Electrical equipment for use within specific voltage limits" (Low-Voltage Directive)
Conformance with this standard has been verified according to EN 61010-2-201.
- 2011/65/EU "Restriction of the use of certain hazardous substances in electrical and electronic equipment" (RoHS Directive)

EU Declaration of Conformity

The associated declaration of conformity is available on the Internet at the following address:
SIMATIC IPC1047 certificates
(<https://support.industry.siemens.com/cs/ww/en/ps/25596/cert>).

ISO 9001 certificate

The Siemens quality management system for our entire product creation process (development, production and sales) meets the requirements of ISO 9001.

This has been certified by DQS (the German society for the certification of quality management systems).

Software license agreements

If the device is supplied with pre-installed software, you must observe the corresponding license agreements.



The following approvals are available for the device:

- Underwriters Laboratories (UL) according to Standard UL 61010-2-201 Second Edition, File E85972
- Canadian National Standard CAN/CSA-C22.2 No. 61010-2-201 Second Edition

USA	
Federal Communications Commission Radio Frequency Interference Statement	This equipment has been tested and found to comply with the limits for a Class A digital device, pursuant to Part 15 of the FCC Rules. These limits are designed to provide reasonable protection against harmful interference when the equipment is operated in a commercial environment. This equipment generates, uses, and can radiate radio frequency energy and, if not installed and used in accordance with the instruction manual, may cause harmful interference to radio communications. Operation of this equipment in a residential area is likely to cause harmful interference in which case the user will be required to correct the interference at his own expense.
Shielded Cables	Shielded cables must be used with this equipment to maintain compliance with FCC regulations.
Modifications	Changes or modifications not expressly approved by the manufacturer could void the user's authority to operate the equipment.
Conditions of Operations	This device complies with Part 15 of the FCC Rules. Operation is subject to the following two conditions: (1) this device may not cause harmful interference, and (2) this device must accept any interference received, including interference that may cause undesired operation.

Responsible party for Supplier's Declaration of Conformity

Siemens Industry, Inc.

Digital Industries - Factory Automation

5300 Triangle Parkway, Suite 100

Norcross, GA 30092

USA

mail to: amps.automation@siemens.com ([mailto: amps.automation@siemens.com](mailto:amps.automation@siemens.com))

CANADA	
Canadian Notice	This Class A digital apparatus complies with Canadian ICES-003.
Avis Canadien	Cet appareil numérique de la classe A est conforme à la norme NMB-003 du Canada.

WEEE Directive

The device is low-emission, recyclable and meets the requirements of the WEEE Directive 2012/19/EU on the disposal of waste electrical and electronic equipment. Siemens AG is registered with Stiftung EAR, WEEE-Reg. No. DE 23691322.

Technical support

A.1 Service and support

You can find additional information and support for the products described on the Internet at the following addresses:

- Technical support (<https://support.industry.siemens.com/cs/ww/en/>)
- Support request form (<http://www.siemens.com/automation/support-request>)
- After Sales Information System SIMATIC IPC/PG (<http://www.siemens.com/asis>)
- SIMATIC Documentation Collection (<http://www.siemens.com/simatic-tech-doku-portal>)
- Your local representative
(<http://www.automation.siemens.com/mcms/aspa-db/en/Pages/default.aspx>)
- Training center (<http://sitrain.automation.siemens.com/sitrainworld/?AppLang=en>)
- Industry Mall (<https://mall.industry.siemens.com>)

When contacting your local representative or Technical Support, please have the following information at hand:

- Article number of the device (MLFB)
- BIOS version for industrial PC or image version of the device
- Other installed hardware
- Other installed software

Tools & downloads

Please check regularly if updates and hotfixes are available for download to your device. The download area is available on the Internet at the following link:

After Sales Information System SIMATIC IPC/PG (<http://www.siemens.com/asis>)

A.2 Troubleshooting

A.2.1 Problems with device functions

This section provides you with tips on how to locate and/or troubleshoot problems which occur.

Problem	Possible cause	Possible remedy
The device is not operational.	There is no power supply to the device.	<ul style="list-style-type: none"> • Check the power supply, the network cable and the power plug. • Check to see if the on/off switch is in the correct position.
	Device is being operated outside the specified ambient conditions	<ul style="list-style-type: none"> • Check the ambient conditions. • After transport in cold weather, wait approximately 12 hours before switching on the device.
The monitor remains dark.	The monitor is switched off.	Switch on the monitor.
	The monitor is in "powersave" mode.	Press any key on the keyboard.
	The brightness button has been set to dark.	Increase brightness using the brightness button. For detailed information, refer to the monitor operating instructions.
	The power cable or the monitor cable is not connected.	<ul style="list-style-type: none"> • Check whether the power cable has been properly connected to the monitor and to the system unit or to the grounded shockproof outlet. • Check whether the monitor cable has been properly connected to the system unit and to the monitor. <p>If the monitor screen still remains dark after you have performed these checks and measures, contact your technical support team.</p>
The mouse pointer does not appear on the screen.	The mouse driver is not loaded.	Check whether the mouse driver is properly installed and available when you start the user program. Detailed information about the mouse driver is available in the corresponding documentation.
	The mouse is not connected.	<ul style="list-style-type: none"> • Check whether the mouse cord is properly connected to the system unit. • If you use an adapter or extension for the mouse cable, also check these connectors. <p>If the mouse pointer still does not appear on the screen after you have performed these checks and actions, contact your technical support team.</p>
Wrong time and/or date on the PC.	Incorrect time or time zone set in the BIOS	<ol style="list-style-type: none"> 1. Press during booting to open the BIOS Setup. 2. Set the time and date in the setup menu.
Although the BIOS setting is correct, the time and date are still wrong.	The backup battery is dead.	Replace the backup battery.

Problem	Possible cause	Possible remedy
USB device is not functioning.	The USB ports are disabled in BIOS.	Enable the USB port or use a different USB port.
	USB 2.0 device connected although USB 2.0 is disabled.	Enable USB 2.0.
	Operating system does not support the USB ports.	<ul style="list-style-type: none"> Turn on USB Legacy Support for mouse and keyboard. For other devices, you need the USB device drivers for the required operating system.
The startup of a Windows operating system on a GPT data carrier is aborted with the following error message: "Status: 0xc0000225 Info: The boot selection failed because a required device is inaccessible".	The boot parameters in the boot loader file "BCD" are incorrect or damaged.	Run "Startup and Repair" from Microsoft Windows: <ol style="list-style-type: none"> 1. Connect the USB stick (Recovery). 2. Start the boot manager using the <F12> key during booting 3. Select the line with "UEFI" in front of the drive of the USB stick. 4. Click "Next" in the language selection window. 5. In the following "Install Windows" dialog, click "Repair your computer" or press the <R> key. The "System Recovery Options" dialog appears. The system is checked for errors. 6. Next, click "Repair and restart".

Redundant power supply

Problem	Possible cause	Possible remedy
Device failure despite redundant power supply in case of power failure	<ul style="list-style-type: none"> One module is not switched on Both modules are connected so the same AC circuit 	<ul style="list-style-type: none"> Switch on both modules Connect modules to separate AC circuits

A.2.2 Problems with the RAID system and device startup

Problem	Possible cause	Possible remedy
The RAID software reports the following errors: <ul style="list-style-type: none"> The RAID plug-in failed to load, because the drive is not installed. The Serial ATA plug-in failed to load, because the driver is not installed correctly. The Intel® Matrix Storage Console was unable to load a page for the following reason: <ul style="list-style-type: none"> A plug-in did not provide a page for the selected device A plug-in failed to load 	RAID is not activated	The messages have no negative effect on the operation of the device and can be ignored. Acknowledge the messages.
After changing the drive, the system does not boot from the RAID system	RAID system does not have highest boot priority	BIOS setup, Boot menu: <ul style="list-style-type: none"> Permit RAID system in the boot priority Set the RAID system to be first in the boot priority order.
After changing the drive, "unused" is indicated for the relevant SATA port	System was booted without functioning drive. The removable drive bay might not be switched on.	Reboot the system with a functioning drive.

Problem	Possible cause	Possible remedy
Computer does not boot or "Boot device not found" is displayed	<ul style="list-style-type: none"> The boot device is not permitted The boot device is not in first place of the boot priority in the BIOS setup The boot data carrier is set up with GPT and UEFI boot is deactivated in the BIOS setup 	<ul style="list-style-type: none"> In the BIOS setup "Boot" menu, permit the boot device in the boot priority In the BIOS setup "Boot" menu, change the boot priority of the Boot device Activate UEFI boot in the BIOS setup.
RAID software cannot be started	<ul style="list-style-type: none"> No Windows password The Windows password was set up subsequently Main memory capacity < 4 GB 	<ul style="list-style-type: none"> Uninstall and then reinstall RAID software Increase main memory capacity to at least 4 GB.
RAID software displays no details of the RAID system	<ul style="list-style-type: none"> No Windows password The Windows password was set up subsequently 	<ul style="list-style-type: none"> Uninstall and then reinstall RAID application
Adaptec Storage Manager software cannot be started	Certificate error	Change address in the link to the Adaptec Storage Manager software to "localhost". Requirement: The certificate is stored in the "Trusted Root Certification Authorities" certificate store and is not expired.

A.2.3 Problems when using expansion cards

Problem	Possible cause	Possible remedy
The PC crashes during startup.	<ul style="list-style-type: none"> I/O addresses are assigned twice. Hardware interrupts and/or DMA channels are assigned twice Signal frequencies or signal levels are not adhered to Different connector pin assignments 	<p>Check your computer configuration:</p> <ul style="list-style-type: none"> If the computer configuration corresponds with factory state, please contact your technical support team. If the computer configuration has changed, restore the original factory settings. Remove all third-party expansion cards, then restart the PC. If the error no longer occurs, the third-party expansion card was the cause of the fault. Replace this expansion card with a Siemens card or contact the card supplier.
	PCIe Gen1 expansion card does not behave according to specification.	<ol style="list-style-type: none"> Remove the expansion card. Set the respective setup parameter "PCIe Speed" permanently to "Gen1" in the "Advanced > PCI Express Configuration" menu, submenu "PCI Express Root Port #" of the BIOS Setup. Set the respective setup parameter "PEG# - Gen X" permanently to "Gen1" in the "Advanced > Video Configuration" menu, submenu "Pci Express Graphic" of the BIOS Setup. Install the expansion card again.





Markings and symbols

B.1 Overview

The following tables show all the symbols which may be found on your SIMATIC industrial PC in addition to the symbols which are explained in the operating instructions.

The symbols on your device may vary in some details from the symbols shown in the following tables.











B.2 Safety

Symbol	Meaning	Symbol	Meaning
	Warning, observe the supplied documentation.		Front door is closed. The removable drive tray is locked ¹
	Devices contain dangerous voltages		Front door is open
	Follow the instructions		



¹ Only with drive cage type A with removable drives

B.3 Certificates, approvals and markings

The following table shows symbols relating to certificates, approvals and markings which may be on the device. You can find more information in the operating instructions for your device:





















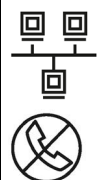

Symbol	Meaning	Symbol	Meaning
	Approved for Australia and New Zealand		Marking for the Eurasian Customs Union
	Approved for China		Test mark of Factory Mutual Research
	CE markings for European countries		Marking of Federal Communications Commission for the USA
	EFUP (Environment Friendly Use Period) marking for China		Approved for Korea
	Test mark of the Underwriters Laboratories		Disposal information, observe the local regulations.
	Approval for India		

B.4 Operator controls

Symbol	Meaning	Symbol	Meaning
	On/off switch ¹ , without electrical isolation		On/off switch, without electrical isolation

¹ Only with single power supply

B.5 Interfaces

Symbol	Meaning	Symbol	Meaning
	Connection to the power supply		PS/2 mouse interface
	Protective conductor terminal		PS/2 keyboard-interface
 	Connection for functional earthing (equipotential bonding line)		Multimedia Card Reader
DPP	DisplayPort interface		Smart Card Reader
	DVI port		Line In
	Monitor output (VGA)		Line Out
LAN 	LAN interface, not approved for connecting WAN or telephone	 	Microphone input
	Serial interface		Universal audio jack
	USB port		Headphone output
	USB 2.0 high-speed port		
	USB 3.0 super-speed port		
	USB 3.1 SuperSpeedPlus interface		

Abbreviations

Abbreviation	Term	Meaning
AC	Alternating current	Alternating current
ACPI	Advanced Configuration and Power Interface	
AGP	Accelerated Graphics Port	High speed bus system
AHCI	Advanced Host Controller Interface	Standardized controller interface for SATA devices.
APIC	Advanced Programmable Interrupt Controller	Extended programmable interrupt controller
APM	Advanced Power Management	Tool for monitoring and reducing power consumption of the PC
AT	Advanced Technology	
ATA	Advanced Technology Attachment	
ATX	AT-Bus-Extended	
AWG	American Wire Gauge	US standard for the cable diameter
BIOS	Basic Input Output System	Basic Input Output System
CAN	Controller Area Network	
CD-ROM	Compact Disc – Read Only Memory	Removable storage medium for large data volumes
CD-RW	Compact Disc – Rewritable	Rewritable CD
CE	Communauté Européenne (CE symbol)	The product is in conformance with all applicable EC directives
CGA	Color Graphics Adapter	Standard monitor interface
CIRA	Client Initiated Remote Access	Administration of AMT PCs not in the intranet
CLK	Clock pulse	Clock signal for controllers
CMOS	Complementary Metal Oxide Semiconductors	Complementary metal oxide semiconductors
COA	Certificate of authentication	Microsoft Windows Product Key
COL	Certificate of License	License authorization
COM	Communications Port	Term for the serial interface
CP	Communication Processor	Communication computer
CPU	Central Processing Unit	Processor
CRT	Cathode Ray Tube	
CSA	Canadian Standards Association	Canadian organization for tests and certifications according to own or binational standards (with UL / USA) standards
CTS	Clear To Send	Clear to send
DRAM	Dynamic Random Access Memory	
DC	Direct Current	DC current
DCD	Data Carrier Detect	Data carrier signal detection
DDRAM	Double Data Random Access Memory	Memory chip with high-speed interface
DHCP	Dynamic Host Configuration Protocol	Protocol for configuring IP networks
DMA	Direct Memory Access	Direct memory access
DP	Display Port	New powerful digital monitor port

Abbreviation	Term	Meaning
DQS	Deutsche Gesellschaft zur Zertifizierung von Qualitätsmanagement mBH	
DSR	Data Set Ready	Ready for operation
DTK	Developer Tool Kit	Tools for software development, testing, configuration etc.
DTR	Data Terminal Ready	Data terminal is ready
DVI	Digital Visual Interface	Digital display interface
DVI-I	Digital Visual Interface	Digital display interface with digital and VGA signals
ECC	Error checking and correction	Error correction code
ECP	Extended capability port	Extended parallel port
EFI	Extensible Firmware Interface	
EGA	Enhanced Graphics Adapter	PC to monitor interface
ESD	Components sensitive to electrostatic charge	
DM	Electronic Manual	
EIDE	Enhanced Integrated Drive Electronics	An enhancement of the IDE standard
EISA	Extended Industry Standard Architecture	Extended ISA standard
EMM	Expanded Memory Manager	Manages memory expansions
EM64T	Extended Memory 64 technology	
EN	European standard	
EPROM / EEPROM	Erasable Programmable Read-Only Memory / Electrically Erasable Programmable Read-Only Memory	Plug-in submodules with EPROM/EEPROM chips
EPP	Enhanced Parallel Port	Bi-directional Centronics interface
ESC	Escape character	Control character
EFW	Enhanced Write Filter	
FAQ	Frequently Asked Questions	FAQs
FAT 32	File Allocation Table 32-bit	32-bit file allocation table
FBWF	File-Based Write Filter	
FQDN	Fully qualified domain name	Full name of a domain
FSB	Front Side Bus	
GND	Ground	Chassis ground
GPT	Globally Unique Identifier Partition Table	
HD	Hard disk	Hard disk
HDA	High Definition Audio	
HDD	Hard Disk Drive	Hard disk drive
HU	Height unit	
HMI	Human Machine Interface	User interface
HORM	Hibernate Once - Resume Many	
HT	Hyper-Threading	
HTML	Hyper Text Markup Language	Script language for creating Internet pages.
HTTP	Hypertext Transfer Protocol	Protocol for data transfer on the Internet
Hardware	Hardware	
I/O	Input/Output	Data input/output on computers

Abbreviation	Term	Meaning
IAA	Intel Application Accelerator	
IDE	Integrated Device Electronics	
IDER	IDE Redirection	Remotely mounting an ISO file as a drive
IEC	International Electrotechnical Commission	
IGD	Integrated Graphics Device	
IP	Ingress Protection	Degree of protection
IR	Infrared	Infrared
IRDA	Infrared Data Association	Standard for data transfer via IR module
IRQ	Interrupt Request	Interrupt request
ISA	Industry Standard Architecture	Bus for expansion cards
ITE	Information Technology Equipment	
KVM	Keyboard, Video, Mouse	
L2C	Level 2 cache	
LAN	Local Area Network	Computer network that is limited to a local area.
LCD	Liquid Crystal Display	Liquid crystal display
LRDIMM	Load Reduced Dual Inline Memory Module	Load-reduced DIMMs with additional memory buffer chip
LED	Light Emitting Diode	Light emitting diode
LPT	Line Printer	Printer port
LVDS	Low Voltage Differential Signaling	
LW	Drive	
MAC	Media access control	Media access control
MC	Memory card	Memory card in credit card format
MLC	Multi-level cell	Memory cells in which generally more than one bit per cell are saved
MLFB	Machine-readable product designation	
MMC	Micro Memory Card	Memory card of the format 32 mm x 24.5 mm
MPI	Multipoint-capable interface for programming devices	
MTBF	Mean Time Between Failures	
MUI	Multilanguage User Interface	Language localization in Windows
NA	Not Applicable	
NAMUR	Normenarbeitsgemeinschaft für Mess- und Regelungstechnik in der chemischen Industrie (standardization body for instrumentation and control technology in the chemicals industry)	
NC	Not Connected	Not connected
NCQ	Native Command Queuing	Automatic re-sorting of the file and disk access, for increased performance
NEMA	National Electrical Manufacturers Association	Syndicate of manufacturers of electrical components in the USA
NMI	Non Maskable Interrupt	Interrupt the processor can not reject
NTFS	New Techniques File System	Secure file system for Windows
ODD	Optical Disk Drive	

Abbreviation	Term	Meaning
OLE	Object Linking and Embedding	Coordination of various Microsoft documents, e.g. spreadsheet in text editor.
OPC	OLE for Process Control	Standardized interface for industrial processes
PATA	Parallel ATA	
PC	Personal computer	
PCI	Peripheral Component Interconnect	High-speed expansion bus
PCIe	Peripheral Component Interconnect express	High-speed serial, differential full-duplex PtP interface with high data rate.
PCMCIA	Personal Computer Memory Card International Association	
PE	Protective Earth	Protective conductor
PEG	PCI Express Graphics	
PIC	Programmable Interrupt Controller	Programmable interrupt controller
PRTC	Protected Real Time Clock	Clock in the management engine MEBx
PXE	Preboot Execution Environment	Software for running new PCs without hard disk data via the network
RAID	Redundant Array of Independent Disks	Redundant hard disk array
RAL	Restricted Access Location	Installation of device in operating facilities with restricted access - for example, a locked switchgear cabinet
RAM	Random Access Memory	Main memory
RDIMM	Register Dual Inline Memory Module	Load-reduced DIMMs with additional RAM register
ROM	Read-Only Memory	
RS 485	Reconciliation Sublayer 485	Bi-directional bus system designed for up to 32 nodes.
RTC	Real Time Clock	Real-time clock
RTS	Reliable Transfer Service	Request to send
RxD	Receive Data	Data transfer signal
SAS	Serial attached SCSI	
SATA	Serial Advanced Technology Attachment	
SCSI	Small Computer System Interface	
SDRAM	Synchronous DRAM	
SELV	Safety Extra Low Voltage	Safety extra low voltage
SLC	Second Level Cache	
	Single-level cell	Memory cells in which only one bit per cell is saved
SMART	Self Monitoring Analysis and Reporting Technology	Hard disk error diagnostics program
SMS	Short Message Service	Short message via telecommunication network
SNMP	Simple Network Management Protocol	Network protocol
SO-DIMM	Small Outline Dual Inline Memory Module	
SOL	Serial over LAN	Text-based remote control
SOM	SafeCard on Motherboard (SOM)	
SPP	Standard Parallel Port	Synonym for parallel port
SRAM	Static Random Access Memory	Static RAM
SSD	Solid State Drive	

Abbreviation	Term	Meaning
SVGA	Super Video Graphics Array	Enhanced VGA standard with at least 256 colors
SVP	Serial number of the device	
SW	Software	
TCO	Total Cost of Ownership	
TFT	Thin-Film-Transistor	Type of LCD flat-screen
TTY	Tele Type	Asynchronous data transfer
TxD	Transmit Data	Data transfer signal
TXT	Trusted Execution Technology	Hardware implementation
TWD	Watchdog Time	Watchdog monitoring time
UEFI	Unified Extensible Firmware Interface	
UL	Underwriters Laboratories Inc.	US organization for tests and certifications according to own or binational standards (with CSA / Canada) standards.
UMA	Unified Memory Architecture	Video memory
URL	Uniform Resource Locator	Designation of the full address of an Internet page
USB	Universal Serial Bus	
UXGA	Ultra Extended Graphics Array	Graphic standard, maximum resolution 1600x1200 pixels.
V.24	2 × 12-pin connection	ITU-T standardized recommendation for data transfer via serial ports.
VCC	Voltage at the Common Collector	Positive supply voltage of integrated circuits
VDE	Verein deutscher Elektrotechniker (Union of German Electrical Engineers)	
VGA	Video Graphics Array	Video adapter which meets industrial standard
VRM	Voltage Regulator Module	
VT	Virtualization Technology	Intel technology with which a virtually closed environment can be made available.
VT-D	Virtualization Technology for Directed I/O	Enables the direct assignment of a device (e.g. network adapter) to a virtual device.
WAN	Wide Area Network	
WAV	Wave Length Encoding	Loss-free file format for audio data.
WD	Watchdog	Program monitoring with error detection and alarming.
WLAN	Wireless LAN	Wireless local area network
WOL	Wake on Local Area Network	
WWW	World Wide Web	
XD	Extended Disable Capability	Hardware implementation
XGA	Extended Graphics Array	Graphic standard, maximum resolution 1024x768 pixels.
ZMM	Zero Maintenance Cache Protection Module	Maintenance-free cache unit for saving cache contents

Glossary

AHCI mode

AHCI is a standardized method to address the SATA controller. AHCI describes a structure in the RAM, which contains a general area for control and status, as well as a command list.

APIC mode

Advanced Peripheral Interrupt Controller. 24 interrupt lines are available.

ATAPI CD-ROM Drive

AT Bus Attachment Packet Interface (connection to AT bus) CD-ROM drive

Backup

Duplicate of a program, data medium or database, used either for archiving purposes or for the protection of vital and non-replaceable data against loss when the working copy is corrupted. Certain applications automatically generate backup copies of data files, and manage both the current and the previous versions on the hard disk.

Baud

Physical unit for the step speed in signal transmission. Defines the number of transferred signal states per second. With only two states, one baud is equivalent to a transmission rate of 1 bps.

Cache

High-speed access buffer for interim storage (buffering) of requested data.

CE marking

Communauté Européene. The CE symbol confirms the conformity of the product with all applicable EC directives such as the EMC Directive.

Chipset

Located on the motherboard, connects the processor with the RAM, the graphics controller, the PCI bus, and the external interfaces.

Cold restart

A start sequence, starting when the computer is switched on. During a cold restart, the system usually performs some basic hardware checks and then loads the operating system from the hard disk to work memory -> boot.

COM interface

The COM interface is a serial V.24 interface. The interface is suitable for asynchronous data transfer.

Configuration files

These are files containing data which define the configuration after restart. Examples of such files are CONFIG.SYS, AUTOEXEC.BAT and the registry files .

Controller

Integrated hardware and software controllers that control the functions of certain internal or I/O devices (for example, the keyboard controller).

Disc-At-Once

With this burning technique, data are written to a CD in a single session, and the CD is then closed. Further write access is then no longer possible.

DP

Display Port: New digital monitor interface.

Drivers

Program parts of the operating system. They adapt user program data to the specific formats required by I/O devices such as hard disk, printers, and monitors.

ECC

Error checking and correction is a method for detecting and correcting errors when saving and transferring data, frequently used in conjunction with RAM modules with and without ECC.

EMC directive

EU directive for electromagnetic compatibility. Compliance is confirmed by the CE symbol and the EC certificate of conformity.

Energy management

The energy management functions of a modern PC allow individual control over the current consumption of vital computer components (e.g. of the monitor, hard disk and CPU), by restricting their activity based on the current system or component load. Energy management is of particular importance for mobile PCs.

Energy options

The energy options can be used to reduce energy consumption of the computer, while keeping it ready for immediate use. This can be configured in Windows by selecting Settings > Control Panel > Energy options.

ESD directive

Directive for using electrostatic sensitive components.

Ethernet

Local network (bus structure) for text and data communication with a transfer rate of 10/100/1000 Mbps.

Execute Disable Capability

Hardware implementation that prevents mutual memory accesses by programs and applications. It is only effective when all relevant system components, such as processors, operating systems and applications are supported.

Extensible Firmware Interface (EFI)

Refers to the central interface between the firmware, the individual components of a computer and the operating system. EFI is located logically beneath the operating system and represents the successor to PC BIOS, focusing on 64-bit systems.

File Based Write Filter (FBWF)

Configurable write filter to protect individual files from write access.

Formatting

Basic partitioning of memory space on a magnetic data medium into tracks and sectors. Formatting deletes all data on a data medium. All data media must be formatted prior to their first use.

HORM

"Hibernate once - resume many" is a method for fast booting from a single Hibernate file that only needs to be created once. HORM ensures restoration of a uniform, saved system state when booting.

Hub

A term in network technology. In a network, a device joining communication lines at a central location, providing a common connection to all devices on the network.

Hyper Threading

HT technology (multi-threading) enables the parallel computing of processes. HT is only effective when all relevant system components, such as processors, operating systems and applications are supported.

IGD

Integrated Graphics Device. Graphics interface integrated in the chipset.

Image

This refers to the image, for example, of hard disk partitions saved to a file in order to restore them when necessary.

Intel VT

The Intel Virtualization Technology (IVT) is the implementation of a secure closed environment for applications. Special (visualization) software on a VT-capable processor is required for its use.

Interface

See Interface.

- Physical interconnection (cable) of hardware elements such as PLCs, PCs, programming devices, printers or monitors.
- Interface for interactive software applications.

Interface

See Interface.

- Physical interconnection (cable) of hardware elements such as PLCs, PCs, programming devices, printers or monitors.
- Interface for interactive software applications.

LAN

Local Area Network: LAN is a local network that consists of a group of computers and other devices that are distributed across a relatively restricted range and are linked with communication cables. The devices connected to a LAN are called nodes. The purpose of networks is the mutual use of files, printers or other resources.

Legacy Boot Device

Conventional drives can be used as USB devices.

Legacy USB support

Support of USB devices, e.g. mouse, keyboard, on the USB ports without driver.

License key

The license key represents the electronic license stamp of a license. Siemens provides the license keys for protected software.

Low-voltage directive

EC Product Safety Directive relating to the safety of products which are operated on low voltage (50 V AC to 1000 V AC, 70 V DC to 1500 V DC) and not specified in other directives. Compliance is confirmed by the CE symbol and the EC certificate of conformity.

Module

Modules are plug-in units for PLCs, programming devices or PCs. They are available as central modules, interface modules, expansion cards or mass storage (mass storage module).

Motherboard

The motherboard is the core of the computer. Here, data are processed and stored, and interfaces and device I/Os are controlled and managed.

Multi-core CPU

Multi-core processors have multiple cores, which significantly increases the speed of computing and simultaneous program execution compared to the previous generation of single-core processors with hyper threading technology.

Operating system

Generic term which describes all functions for controlling and monitoring user program execution, distribution of system resources to the user programs and maintaining the operating mode in conjunction with the hardware.

Packet writing

The CD-RW is used as a disk medium. The CD can then be read only by packet-writing compatible software or has to be finalized. Finalization of a CD closes the CD within an ISO9660 shell. You can still write to the CD-RW several times in spite of finalization. Not all CD drives can read packet-written CDs. There are restrictions to using this method in general data transfer.

PEG interface

PCI Express for Graphics. Graphics interface with 16 PCIe lanes for expansions with graphics modules.

Pixel

PixElement. The pixel represents the smallest element that can be reproduced on-screen or on a printer.

Plug&Play

Generally, a reference to the ability of a computer to automatically configure the system for communication with peripheral devices (for example monitors, modems or printers). The user can plug in a peripheral and "play" it at once without manually configuring the system. A Plug&Play PC requires both a BIOS that supports Plug&Play and a Plug&Play expansion card.

PXE server

A Preboot Execution Environment server is part of a network environment and can provide software to connected computers even before they boot. This can involve operating system installations or servicing tools, for example.

RAID

Redundant Array of Independent Disks: Data storage system which is used to save data and the corresponding error correction codes (parity bits, for example) to at least two hard disk volumes in order to enhance reliability and performance. The hard disk array is controlled by management programs and a hard disk controller for error correction. The RAID system is usually implemented in network servers.

Recovery

Contains the tools for configuring hard disks and the Windows operating system.

Redundancy

Function blocks are available several times identically and thus increase the reliability and operational safety. Example redundant power supply: Only one power supply is required in normal operation. Two power supplies are available in redundant operation: The second power supply ensures the power supply of the device in the event of a failure of the first.

Reset

Hardware reset: Reset/restart of the PC using a button/switch.

Restart

Warm restart of an operating computer without switching off the power supply <Ctrl + Alt + Del>.

ROM

Read-Only Memory ROM is a read-only memory in which every memory location can be addressed individually. The programs or data are permanently stored and are not lost in the event of a power failure.

S.M.A.R.T

The Self-Monitoring, Analysis and Reporting Technology (SMART or S.M.A.R.T.) is an industry standard integrated in storage media. It makes for permanent monitoring of important parameters and early detection of imminent problems.

SAS

Serial SCSI interface for connection of hard disk drives, for example, with serial data transmission.

SATA

Serial ATA Interface for hard disk drives and optical drives with serial data transmission.

Session-At-Once

In session at once, the CD can be written to both with an audio session and a data session. The two sessions are written to at once (as in disc at once).

SETUP (BIOS Setup)

A program in which information about the device configuration (that is the configuration of the hardware on the PC/PG) is defined. The device configuration of the PC/PG is preset with defaults. Changes must therefore be entered in the SETUP if a memory expansion, new modules or a new drive are added to the hardware configuration.

SSD

A Solid State Drive (SSD) is a drive that can be installed like any other hard disk drive; it does not contain a rotating disk or other moving parts because only semiconductor memory chips of similar capacity will be used. This design makes SSDs more rugged, provides shorter access times, low energy consumption and rapid data transfer.

Track-At-Once

In track-at-once recording, a CD can be written to in bits in several sessions if the CD was not closed.

Troubleshooting

Error cause, cause analysis, error correction

Trusted Execution Technology

Hardware implementation that allows secured execution of programs and applications. It is only effective when all relevant system components, such as processors, operating systems and applications are supported.

Wake on LAN

The Wake on Local area network (WOL) function allows the PC to be started via the LAN interface.

Warm restart

The restart of a computer after a program was aborted. The operating system is loaded and restarted again. The CTRL+ ALT+ DEL hotkey can be used to initiate a warm restart.

WLAN

Wireless LAN is a local network that transmits data via radio waves, infrared light or other wireless technology. Wireless LAN is mainly used for mobile computer applications in office or factory environments.

ZMM

Zero Maintenance Cache Protection Module is a functional unit of the SAS Raid controller that stores data in the cache of the controller in the case of a voltage failure. This functional unit is maintenance-free.

Index

A

- Abbreviations, 119, 123
- Access protection, 23
- Accessories
 - Hardware, 20
- AHCI controller
 - Making known to the operating system, (See storage controllers)
- Ambient and environmental conditions, 26
- Approval, 111
- Approvals, 26

B

- Back up authorization, 91
- Back up license Key, 91
- Backup battery
 - Maintenance interval, 82
- Battery replacement, 88
- BIOS Setup, 99, 99
- Boot mode
 - Legacy mode, 92, 94
 - UEFI mode, 92, 94
- Bus frame
 - Removing, 76

C

- Canada, 112
- CE marking, 111
- Certificates, 111
 - Approvals, 111
- Change drive
 - Install 5.25" adapter module for removable tray, 58
- Changing the filter pad, 75
- Clock frequency, 91
- COM, 105
- COM interface, (2nd COM interface), 80
 - Mounting, 80
- Condensation, 24
- Contents, 29
 - Checking, 29
- CPU, 11

D

- Data carrier controller
 - Making known to the operating system, 96
- Degree of protection, 101
- Delivery state, 92
- Device
 - Open, 54
- Device fan, 83, 85
 - Fan connector, 84
 - Maintenance interval, 82
 - Removing, 84
 - Removing and installing, 85
- Dimensions, 101
- Disk on Module, 12
- Drive
 - drive in the removable tray, 56
- Drives, 104
 - Maintenance interval, 82
- Dust protection, 101

E

- Electrostatic sensitive devices, 22
- Ethernet
 - Status display, 17
- Ethernet interface, 11
- EU Declaration of Conformity, 111
- Expansion
 - Slots, 11
- Expansion card, 73

F

- Fan, (Device fan), (Device fan)
- Fan cover
 - Front fan, 13
 - Location of filter pad, 83
- FCC, 112
- Filter, (Filter mat), (Filter pad)
- Filter mat
 - Changing, 74
- Filter pad
 - Changing, 83
 - Maintenance interval, 82
- Fire protection enclosure, 24
- Front view, 13

G

GPT volume, 92, 94
Graphics, 104

H

Hard disk
 Slave drive, (Multi-disk system)
Hard disk drive, 104
Hardware RAID controller, 104
Hardware reset, 40
High frequency radiation
 Immunity to interference, 27
Hot swap
 Changing the drive in the removable tray, 56

I

I/O devices
 Connecting, 36
 Safety instructions, 27
Identification data, 29
IEC connector, 35
Immunity to interference, 27
Industry Mall, 20
Installation
 Expansion cards, 73
 Installation locations, 30
 Mounting methods, 32
Interfaces, 11
 COM1, 11
 Serial, 105
 USB, 11, 105
 VGA, 11
Interfaces
 Ethernet, 11

L

Latch for power plug, 35
LEDs, (Status displays)
Legacy mode
 Recovery, 94
 Restore, 92
License key, 91
Limitation of liability, 28, 81

M

Marking
 EU Declaration of Conformity, 111
MBR volume, 92, 94
Microsoft Windows Product Key, 29
Monitoring, 51
 Fan, 51
 Function overview, 11
 Temperature, 51
Monitoring functions, 11
Mounting holes, 32
Multi-disk system, 41

N

Noise emission, 101

O

Open
 Device, 54
Operating system, 12
 Installing, 94
 Shutdown, 39
 Updates, 93, 93
Order no., 29
Output voltage, 106, 107

P

Package contents, 29
Packaging, 29
 Checking, 29
 Removing, 29
Partitions
 Setting up, 96
Permitted mounting positions, 30
Power consumption, 101
Power requirements, 105
Power supply, 11
 AC power supply, 107
Power supply
 AC supply voltage, 106
Processor
 Removal, 90
Processor type, 91
Protection class, 102

R

- RAID, 115
- RAID controller
 - Making known to the operating system, (See storage controllers)
- RAID system, 44
 - Checking status, 47
 - Displaying the defective HDD in the RAID software, 48
 - Integrating a new hard disk, 50
 - Management functions, 42, 45, 47
 - Management functions, 42, 45, 47
 - SAS hardware RAID, 44
- RAID1 system, 45
 - Mounting locations for hard disk drives, 70
 - Replacing a defective hard disk drive, 70
- Rear view, 14, 15
- Recovery, 94
- Removable tray
 - Changing the backplane board, 62
 - Installing the backplane board, 59
- Removal
 - Device fan, 85
- Removing
 - Device fan, 84
 - Processor, 90
- Repairs, 81, 82
- Restore, 92

S

- Safety instructions
 - Ambient and environmental conditions, 26
 - Device and system extensions, 28
 - General, 21
 - I/O devices, 27
 - Mounting, 24
 - Power supply, 34
 - Transportation and storage, 23
- Safety regulations, 102
- SAS, 44
- SAS Hardware RAID, 104
- SAS Hardware RAID system, 44, 44
- Serial number, 29
- Slave drive, (Multi-disk system)
- Slots, 11
- Spare parts, 20
- Spare parts services, 20
- Status displays, 16
 - Ethernet interface, 17
- Status indicators, (Status displays)

- Storage, 23
- Supply voltage, 101
 - For countries other than the USA and Canada, 33
 - USA and Canada, 33
- Switching off the device
 - Disconnecting from the line voltage, 40
 - Forced shutdown, (Hardware reset)
 - Hardware reset, 40
 - Shutting down the operating system, 39
- Switching on the device
 - Configure automatic startup, 39
- System partition, 91

T

- Target system, 92
- Telescopic rails, 32
- Temperature, 103
- Third-party expansion cards, 116
- Tools, 82
- TPM, 11
- Transportation, 23
- Troubleshooting, 113

U

- UEFI mode
 - Recovery, 94
 - Restore, 92
- Updates
 - Operating system, 93, 93
- USB port, 11

V

- VGA interface, 11

W

- Weight, 101
- Windows
 - Microsoft Windows Product Key, 29

X

- X-HDD system, (Multi-disk system)

