

SIEMENS

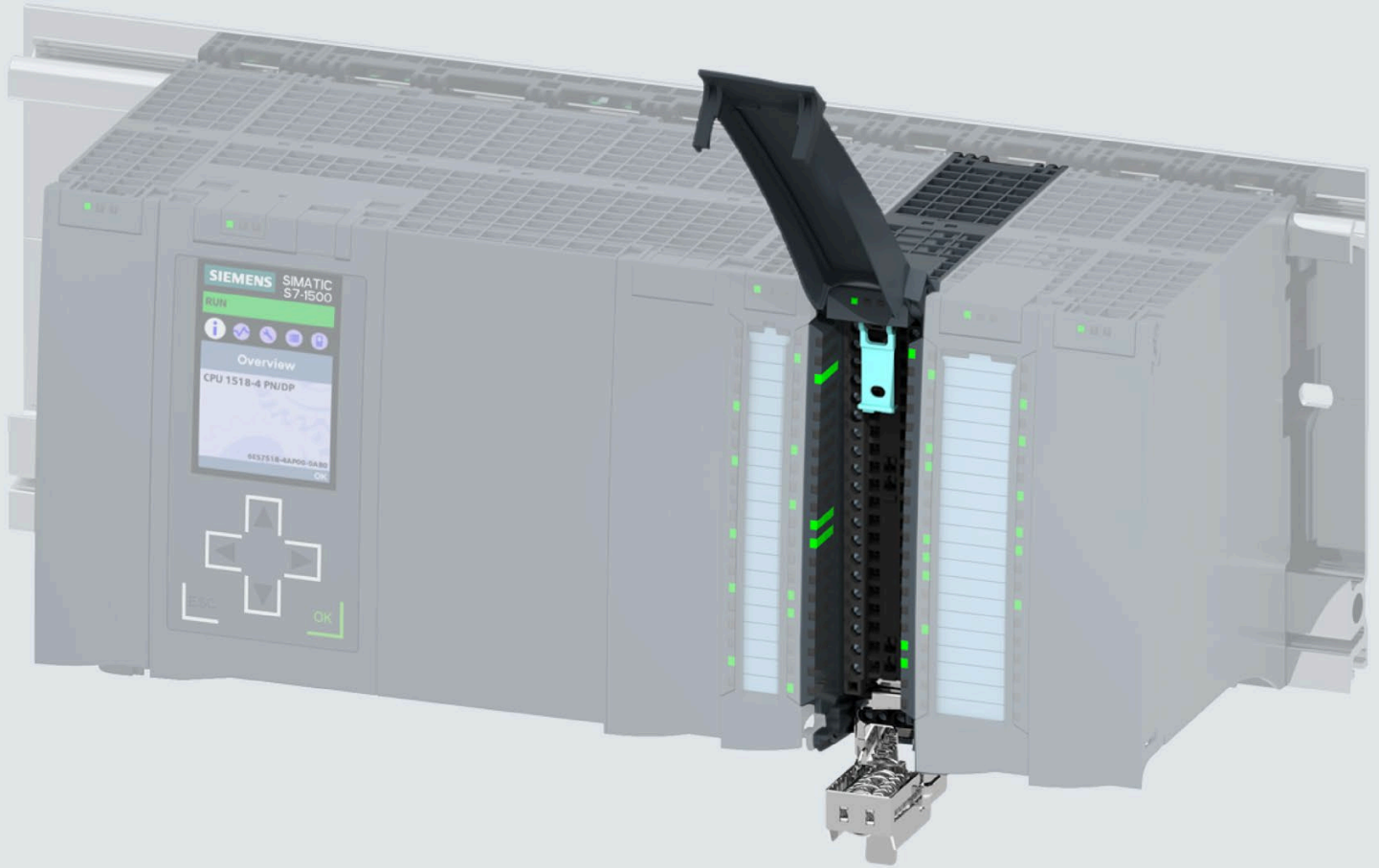

Manual

SIMATIC

S7-1500 / ET 200MP

Analog Input Module
AI 16xI BA (6ES7531-7MH00-0AB0)

Edition

09/2020

support.industry.siemens.com

SIEMENS

SIMATIC

S7-1500/ET 200MP Analog input module AI 16xI BA (6ES7531-7MH00-0AB0)

Equipment Manual

Preface

S7-1500 / ET 200MP
Documentation Guide

1

Product overview

2

Wiring

3

Parameters/address space

4

Interrupts/diagnostics
alarms

5

Technical specifications

6

Dimensional drawing

A

Parameter data records

B



Representation of analog
values

C

Legal information

Warning notice system

This manual contains notices you have to observe in order to ensure your personal safety, as well as to prevent damage to property. The notices referring to your personal safety are highlighted in the manual by a safety alert symbol, notices referring only to property damage have no safety alert symbol. These notices shown below are graded according to the degree of danger.

 DANGER
indicates that death or severe personal injury will result if proper precautions are not taken.
 WARNING
indicates that death or severe personal injury may result if proper precautions are not taken.
 CAUTION
indicates that minor personal injury can result if proper precautions are not taken.
NOTICE
indicates that property damage can result if proper precautions are not taken.

If more than one degree of danger is present, the warning notice representing the highest degree of danger will be used. A notice warning of injury to persons with a safety alert symbol may also include a warning relating to property damage.

Qualified Personnel

The product/system described in this documentation may be operated only by **personnel qualified** for the specific task in accordance with the relevant documentation, in particular its warning notices and safety instructions. Qualified personnel are those who, based on their training and experience, are capable of identifying risks and avoiding potential hazards when working with these products/systems.

Proper use of Siemens products

Note the following:

 WARNING
Siemens products may only be used for the applications described in the catalog and in the relevant technical documentation. If products and components from other manufacturers are used, these must be recommended or approved by Siemens. Proper transport, storage, installation, assembly, commissioning, operation and maintenance are required to ensure that the products operate safely and without any problems. The permissible ambient conditions must be complied with. The information in the relevant documentation must be observed.

Trademarks

All names identified by ® are registered trademarks of Siemens AG. The remaining trademarks in this publication may be trademarks whose use by third parties for their own purposes could violate the rights of the owner.

Disclaimer of Liability

We have reviewed the contents of this publication to ensure consistency with the hardware and software described. Since variance cannot be precluded entirely, we cannot guarantee full consistency. However, the information in this publication is reviewed regularly and any necessary corrections are included in subsequent editions.

Preface

Purpose of the documentation

This manual supplements the system manual S7-1500/ET 200MP (<https://support.industry.siemens.com/cs/ww/en/view/59191792>).

Functions that relate in general to the systems are described in this system manual.

The information provided in this manual and in the system/function manuals supports you in commissioning the systems.

Conventions

The term "CPU" is used in this manual both for the CPUs of the S7-1500 automation system, as well as for interface modules of the ET 200MP distributed I/O system.

Please also observe notes marked as follows:

Note

A note contains important information on the product described in the documentation, on the handling of the product or on the section of the documentation to which particular attention should be paid.

Recycling and disposal

For environmentally friendly recycling and disposal of your old equipment, contact a certified electronic waste disposal company and dispose of the equipment according to the applicable regulations in your country.

Security information

Siemens provides products and solutions with industrial security functions that support the secure operation of plants, systems, machines and networks.

In order to protect plants, systems, machines and networks against cyber threats, it is necessary to implement – and continuously maintain – a holistic, state-of-the-art industrial security concept. Siemens' products and solutions constitute one element of such a concept.

Customers are responsible for preventing unauthorized access to their plants, systems, machines and networks. Such systems, machines and components should only be connected to an enterprise network or the internet if and to the extent such a connection is necessary and only when appropriate security measures (e.g. firewalls and/or network segmentation) are in place.

For additional information on industrial security measures that may be implemented, please visit (<https://www.siemens.com/industrialsecurity>).

Siemens' products and solutions undergo continuous development to make them more secure. Siemens strongly recommends that product updates are applied as soon as they are available and that the latest product versions are used. Use of product versions that are no longer supported, and failure to apply the latest updates may increase customers' exposure to cyber threats.

To stay informed about product updates, subscribe to the Siemens Industrial Security RSS Feed visit (<https://www.siemens.com/industrialsecurity>).

Open Source Software

Open-source software is used in the firmware of the I/O modules. Open Source Software is provided free of charge. We are liable for the product described, including the open-source software contained in it, pursuant to the conditions applicable to the product. Siemens accepts no liability for the use of the open source software over and above the intended program sequence, or for any faults caused by modifications to the software.

For legal reasons, we are obliged to publish the original text of the license conditions and copyright notices. Please read the information relating to this on the Internet (<https://support.industry.siemens.com/cs/ww/en/view/109757558>).

Table of contents

	Preface	3
1	S7-1500 / ET 200MP Documentation Guide	6
2	Product overview	8
	2.1 Properties	8
3	Wiring	10
4	Parameters/address space	13
	4.1 Measuring types and ranges	13
	4.2 Parameters	14
	4.3 Declaration of parameters	16
	4.4 Address space	18
5	Interrupts/diagnostics alarms	23
	5.1 Status and error displays	23
	5.2 Interrupts	25
	5.3 Diagnostics alarms	27
6	Technical specifications	28
A	Dimensional drawing	32
B	Parameter data records	34
	B.1 Parameter assignment and structure of the parameter data records	34
C	Representation of analog values	39
	C.1 Representation of input ranges	40
	C.2 Representation of analog values in the current measuring ranges	41
	C.3 Measured values for wire break diagnostic	42

The documentation for the SIMATIC S7-1500 automation system and the SIMATIC ET 200MP distributed I/O system is arranged into three areas. This arrangement enables you to access the specific content you require.

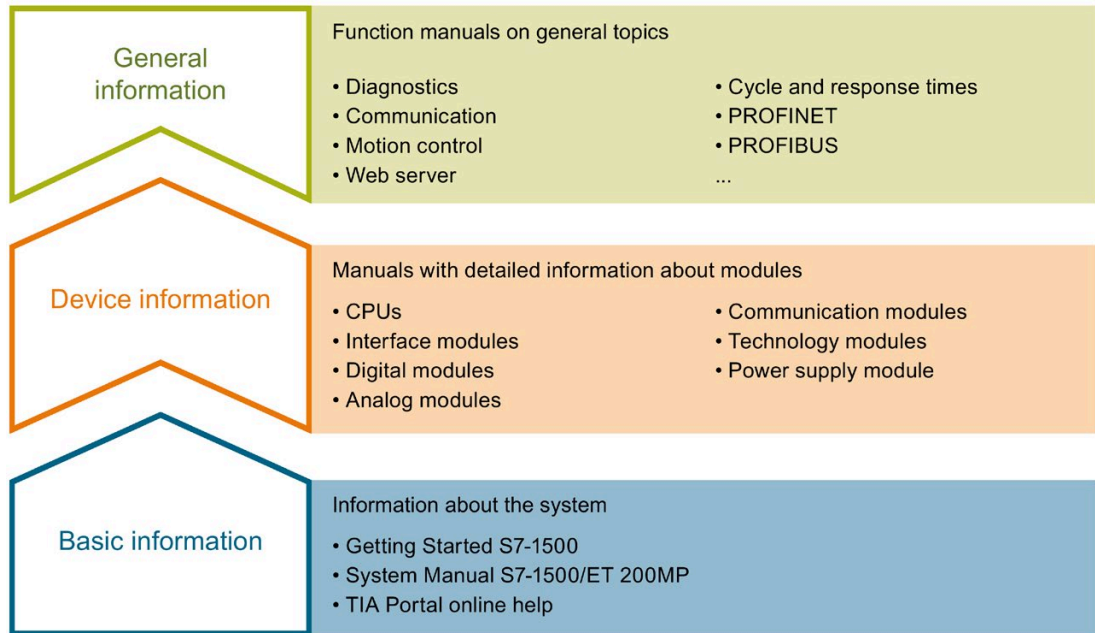

Basic information

The System Manual and Getting Started describe in detail the configuration, installation, wiring and commissioning of the SIMATIC S7-1500 and ET 200MP systems. The STEP 7 online help supports you in the configuration and programming.

Device information

Product manuals contain a compact description of the module-specific information, such as properties, wiring diagrams, characteristics and technical specifications.

General information

The function manuals contain detailed descriptions on general topics regarding the SIMATIC S7-1500 and ET 200MP systems, e.g. diagnostics, communication, motion control, Web server, OPC UA.

You can download the documentation free of charge from the Internet (<https://support.industry.siemens.com/cs/ww/en/view/109742691>).

Changes and supplements to the manuals are documented in a Product Information.

You can download the product information free of charge from the Internet (<https://support.industry.siemens.com/cs/us/en/view/68052815>).

Manual Collection S7-1500/ET 200MP

The Manual Collection contains the complete documentation on the SIMATIC S7-1500 automation system and the ET 200MP distributed I/O system gathered together in one file.

You can find the Manual Collection on the Internet (<https://support.industry.siemens.com/cs/ww/en/view/86140384>).

SIMATIC S7-1500 comparison list for programming languages

The comparison list contains an overview of which instructions and functions you can use for which controller families.

You can find the comparison list on the Internet (<https://support.industry.siemens.com/cs/ww/en/view/86630375>).

"mySupport"

With "mySupport", your personal workspace, you make the best out of your Industry Online Support.

In "mySupport", you can save filters, favorites and tags, request CAx data and compile your personal library in the Documentation area. In addition, your data is already filled out in support requests and you can get an overview of your current requests at any time.

You must register once to use the full functionality of "mySupport".

You can find "mySupport" on the Internet (<https://support.industry.siemens.com/My/ww/en>).

Application examples

The application examples support you with various tools and examples for solving your automation tasks. Solutions are shown in interplay with multiple components in the system - separated from the focus on individual products.

You will find the application examples on the Internet (<https://support.industry.siemens.com/sc/ww/en/sc/2054>).

Product overview

2.1 Properties

Article number

6ES7531-7MH00-0AB0

View of the module

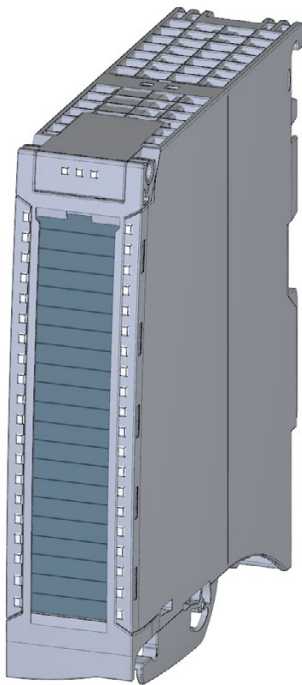

Figure 2-1 View of the AI 16xI BA module

Properties

The module has the following technical properties:

- 16 analog inputs
- Measurement type current
Measuring range +/- 20 mA; 0/4 .. 20 mA can be set per channel
- Resolution 16 bits including sign
- Configurable diagnostics (per channel)
- Hardware interrupt on limit violation can be set per channel (two low and two high limits per channel)

The module supports the following functions:

Table 2- 1 Version dependencies of the module functions

Function	Firmware version of the module	Configuration software	
		STEP 7 (TIA Portal) as of V16 and HSP 0312	GSD file in STEP 7 (TIA Portal) V12 or higher, or STEP 7 V5.5 SP3 or higher
Firmware update	V1.0.0 or higher	X	X
Identification data I&M0 to I&M3	V1.0.0 or higher	X	X
Parameter assignment in RUN	V1.0.0 or higher	X	X
Module-internal Shared Input (MSI)	V1.0.0 or higher	X (PROFINET IO only)	X (PROFINET IO only)

You can configure the module with STEP 7 (TIA Portal) and with a GSD file.

Accessories

The following accessories are supplied with the module and can also be ordered separately as spare parts:

- Shield bracket
- Shield terminal
- Power supply element
- Labeling strips
- U connector
- Universal front door

Other components

You can find additional information on accessories and the article number in the system manual S7-1500/ET 200MP

(<https://support.industry.siemens.com/cs/ww/en/view/59191792>).

This section contains the block diagram of the module and outlines various connection options.

You can find information on wiring the front connector, creating a cable shield, etc. in the Wiring section of the system manual S7-1500/ET 200MP (<https://support.industry.siemens.com/cs/ww/en/view/59191792>).

Note

- You may use and combine the different wiring options for all channels.
 - Do not insert the potential jumpers supplied with the front connector.
-

Abbreviations used

Meaning of the abbreviations used in the following figures:

I_n+/I_n-	Current input channel n (current only)
M_{ANA}	Reference potential of the analog circuit

Infeed element

The module does not require supply voltage through the infeed element. The infeed element is inserted on the front connector and serves solely for shielding.

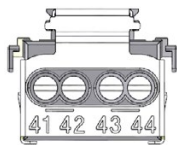
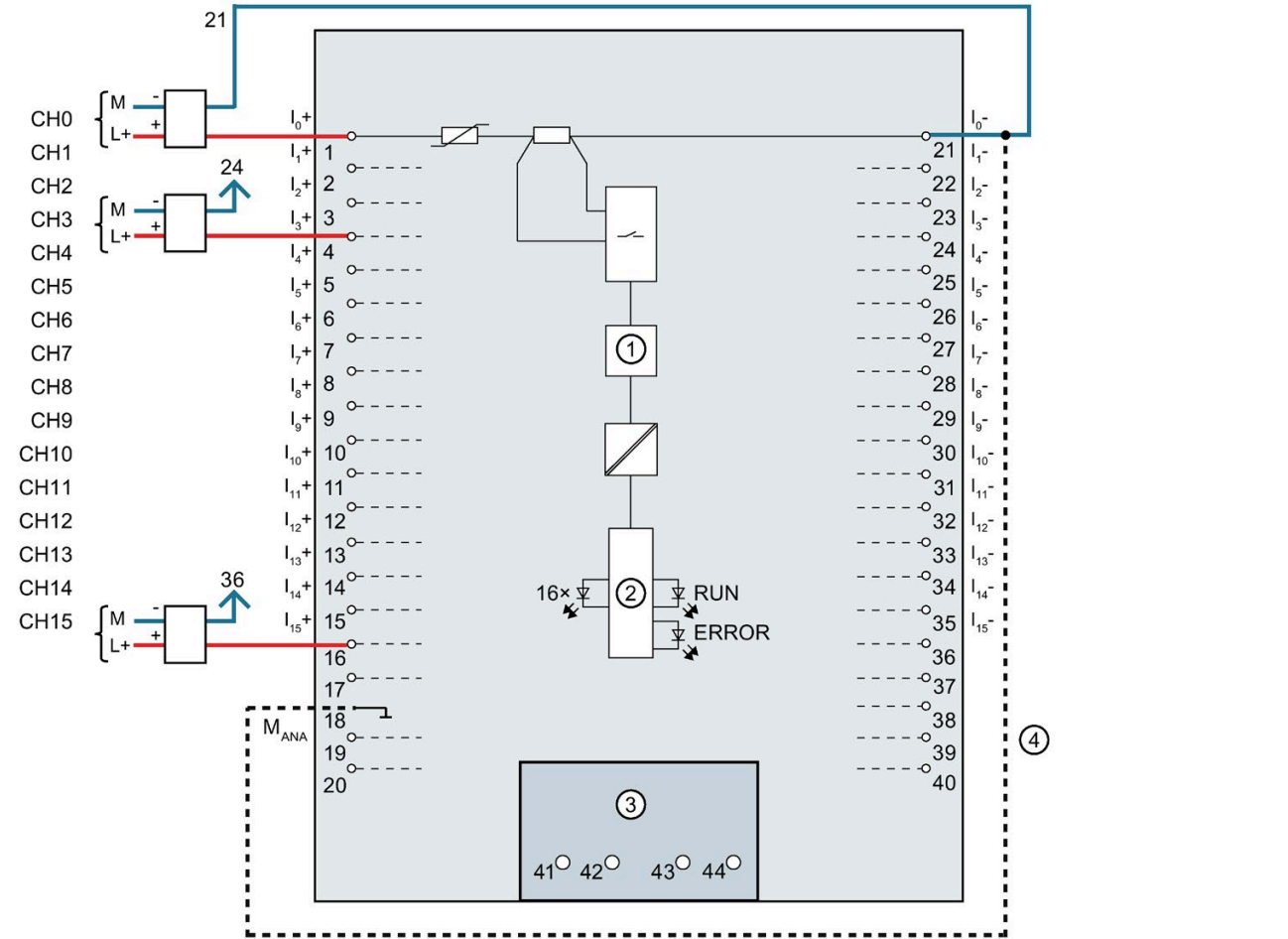

Figure 3-1 Infeed element

Connection: 4-wire transmitters for current measurement

The example in the following figure shows the pin assignment for current measurement with 4-wire transmitters.



- | | | | |
|---|--|-------|--|
| ① | Analog-to-digital converter (ADC) | CHx | Channel or 16 x channel status (green/red) |
| ② | Backplane bus interface | RUN | Status display LED (green) |
| ③ | Infeed element (for shielding only) | ERROR | Error display LED (red) |
| ④ | Equipotential bonding cable (optional) | | |

Figure 3-2 Block diagram and pin assignment for current measurement

Connection: 2-wire transmitters for current measurement

The example in the following figure shows the pin assignment for current measurement with 2-wire transmitters.

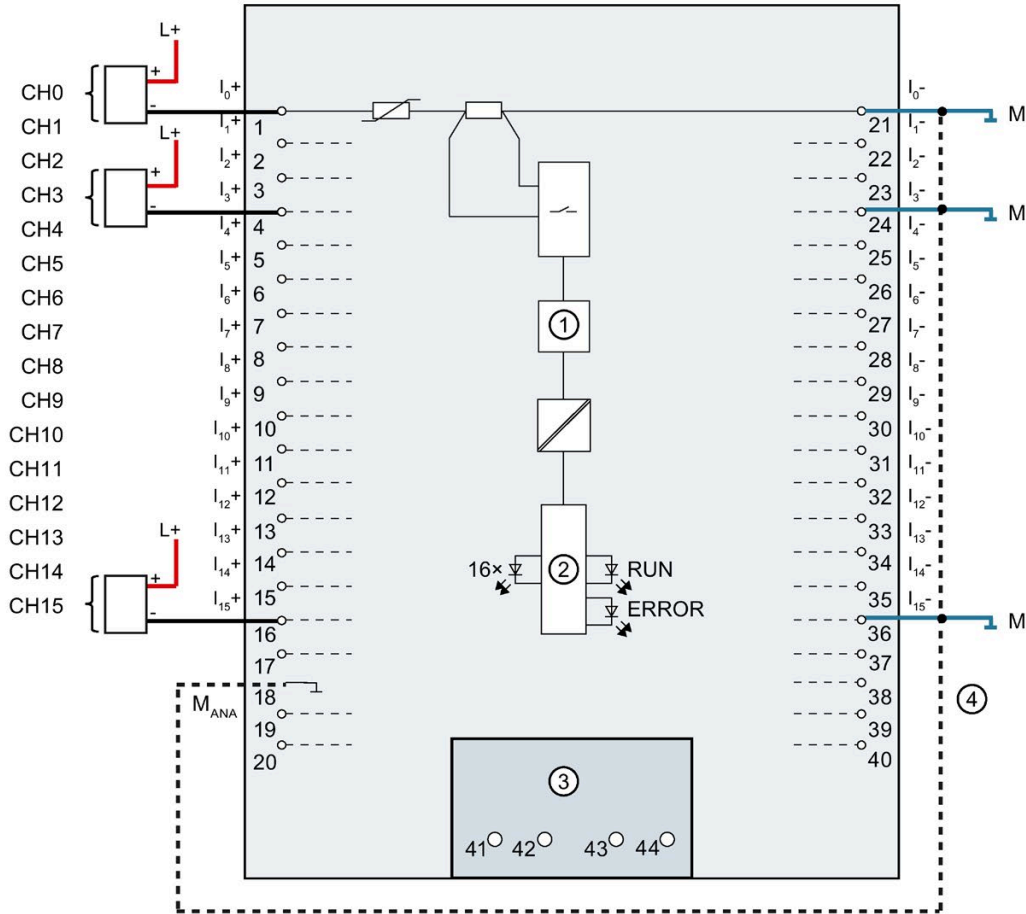

- | | | |
|--|-------|--|
| ① Analog-to-digital converter (ADC) | CHx | Channel or 16 x channel status (green/red) |
| ② Backplane bus interface | RUN | Status display LED (green) |
| ③ Infeed element (for shielding only) | ERROR | Error display LED (red) |
| ④ Equipotential bonding cable (optional) | | |

Figure 3-3 Block diagram and pin assignment for current measurement

Parameters/address space

4.1 Measuring types and ranges

Introduction

The module has the default measurement type current 4WMT and the measuring range ± 20 mA. You need to reassign the module parameters with STEP 7 if you want to use a different measurement type or measuring range.

Deactivate the input if it is not going to be used. The module cycle time is shortened and the interference factors that lead to failure of the module (for example, triggering a hardware interrupt) are avoided.

The following table shows the measurement types and the respective measuring range.

Table 4- 1 Measurement types and measuring ranges

Measurement type	Measuring range	Representation of analog values
Current 2WMT (2-wire transmitter)	4 mA to 20 mA	See Representation of analog values in the current measuring ranges (Page 41)
Current 4WMT (4-wire transmitter)	0 mA to 20 mA 4 mA to 20 mA ± 20 mA	
Disabled	-	-

The tables of the input ranges, overflow, underrange, etc. are available in the appendix Representation of analog values (Page 39).

4.2 Parameters

Parameters of AI 16xI BA

When you assign the module parameters in STEP 7, you use various parameters to specify the module properties. The following table lists the configurable parameters. The effective range of the configurable parameters depends on the type of configuration. The following configurations are possible:

- Central operation with a S7-1500 CPU
- Distributed operation on PROFINET IO in an ET 200MP system
- Distributed operation on PROFIBUS DP in an ET 200MP system

When assigning parameters in the user program, use the WRREC instruction to transfer the parameters to the module by means of data records; refer to the section Parameter assignment and structure of the parameter data records (Page 34).

The following parameter settings for the channels are possible:

Table 4-2 Configurable parameters and their defaults

Parameters	Range of values	Default setting	Parameter assignment in RUN	Scope with configuration software, e.g., STEP 7 (TIA Portal)	
				GSD file PROFINET IO	GSD file PROFIBUS DP
Diagnostics					
• Overflow	Yes/No	No	Yes	Channel	Module ²⁾
• Underflow	Yes/No	No	Yes	Channel	Module ²⁾
• Common mode error	Yes/No	No	Yes	Channel	Module ²⁾
• Wire break ¹⁾	Yes/No	No	Yes	Channel	Module ²⁾
Measuring					
• Measurement type	See chapter Measuring types and ranges (Page 13)	Current 4WMT	Yes	Channel	Channel
• Measuring range		±20 mA	Yes	Channel	Channel
• Interference frequency suppression	400 Hz 60 Hz 50 Hz 10 Hz	50 Hz	Yes	Channel	Module
• Smoothing	None/low/medium/high	None	Yes	Channel	Channel

Parameters	Range of values	Default setting	Parameter assignment in RUN	Scope with configuration software, e.g., STEP 7 (TIA Portal)	
				GSD file PROFINET IO	GSD file PROFIBUS DP
Hardware interrupts					
• Hardware interrupt low limit 1	Yes/No	No	Yes	Channel	--- ³⁾
• Hardware interrupt high limit 1	Yes/No	No	Yes	Channel	--- ³⁾
• Hardware interrupt low limit 2	Yes/No	No	Yes	Channel	--- ³⁾
• Hardware interrupt high limit 2	Yes/No	No	Yes	Channel	--- ³⁾

¹⁾ "Wire break" diagnostics is only available in the measuring range 4 .. 20 mA.

²⁾ You can set the effective range of the diagnostics for each channel in the user program with data records 0 to 15.

³⁾ You can configure the limits for hardware interrupts in the user program with data records 0 to 15.

4.3 Declaration of parameters

Overflow

Enabling of the diagnostics if the measured value violates the high limit.

Underflow

Enabling of the diagnostics when the measured value violates the low limit.

Common mode error

Enabling of diagnostics if the valid common mode voltage is exceeded.

Wire break

Enabling of the diagnostics if the module has no current flow or the current is too weak to be measured at the relevant input.

"Wire break" diagnostics is only available in the measuring range 4 .. 20 mA.

Interference frequency suppression

At analog input modules, this suppresses interference caused by the frequency of the AC network.

The frequency of the AC voltage network may interfere with measured values, particularly for measurements within narrow voltage ranges. For this parameter, the user defines the mains frequency prevailing on his system.

Smoothing

The individual measured values are smoothed using filtering. The smoothing can be set in 4 levels.

Smoothing time = number of module cycles (k) x cycle time of the module.

The following figure shows the number of module cycles after which the smoothed analog value is almost 100%, depending on the set smoothing. It is valid for each signal change at the analog input.

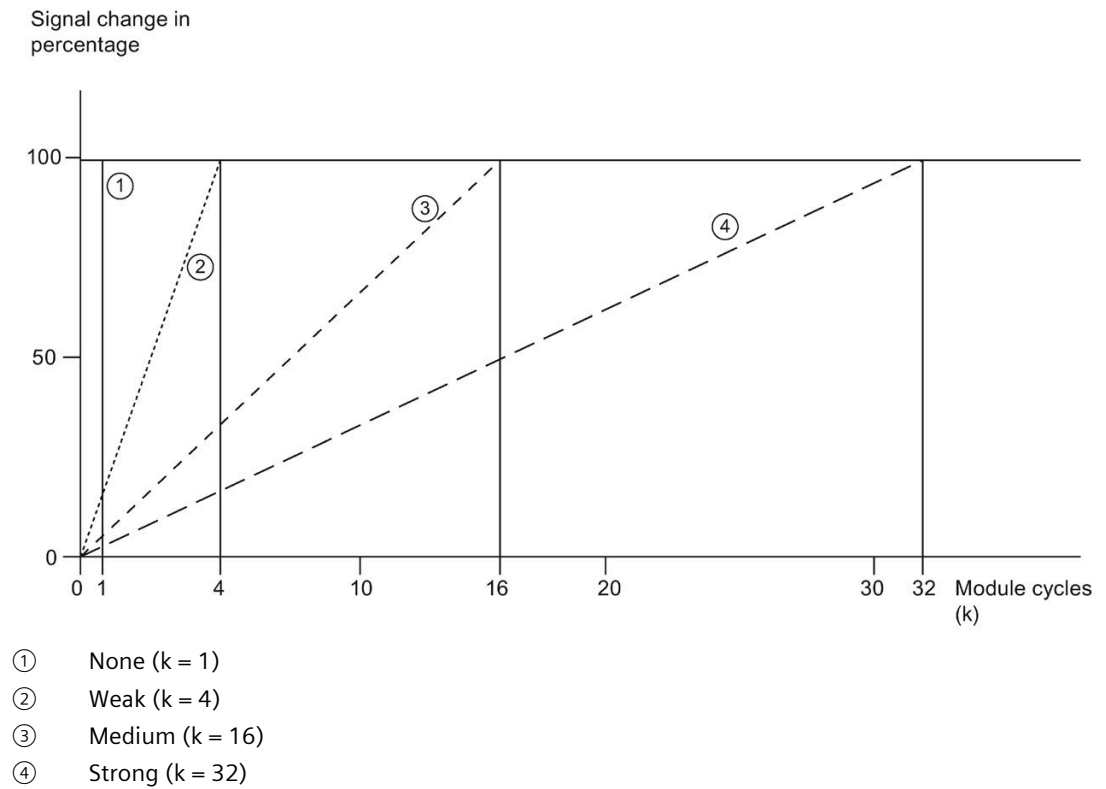

Figure 4-1 Smoothing for AI 16xl BA

Hardware interrupt 1 or 2

Enabling of a hardware interrupt at violation of high limit 1 or 2 or low limit 1 or 2.

Low limit 1 or 2

Specifies the low limit threshold that triggers hardware interrupt 1 or 2.

High limit 1 or 2

Specifies the high limit threshold that triggers hardware interrupt 1 or 2.

4.4 Address space

The module can be configured differently in STEP 7; see following table. Depending on the configuration, additional/different addresses are assigned in the process image of the inputs.

Configuration options of AI 16xI BA

You can configure the module with STEP 7 (TIA Portal) or with a GSD file.

When you configure the module by means of the GSD file, the configurations are available under different abbreviations/module names.

The following configurations are possible:

Table 4-3 Configuration options

Configuration	Short designation/ module name in the GSD file	Configuration software, e.g., with STEP 7 (TIA Portal)	
		Integrated in the hardware catalog STEP 7 (TIA Portal) as of V16 and HSP 0312	GSD file in STEP 7 (TIA Portal) V12 or higher or STEP 7 V5.5 SP3 or higher
1 x 16-channel without value status	AI 16xI BA	X	X
1 x 16-channel with value status	AI 16xI BA QI	X	X
1 x 16-channel with value status for module-internal shared input with up to 4 submodules	AI 16xI BA MSI	X (PROFINET IO only)	X (PROFINET IO only)

Value status (Quality Information, QI)

The value status is always activated for the following module names:

- AI 16xI BA QI
- AI 16xI BA MSI

An additional bit is assigned to each channel for the value status. The value status bit indicates if the read in digital value is valid. (0 = value is incorrect).

Address space of AI 16xl BA

The figure below shows the address space allocation for the configuration as 16-channel module. You can freely assign the start address for the module. The addresses of the channels are derived from the start address.

"IB x" stands, for example, for the module start address input byte x.

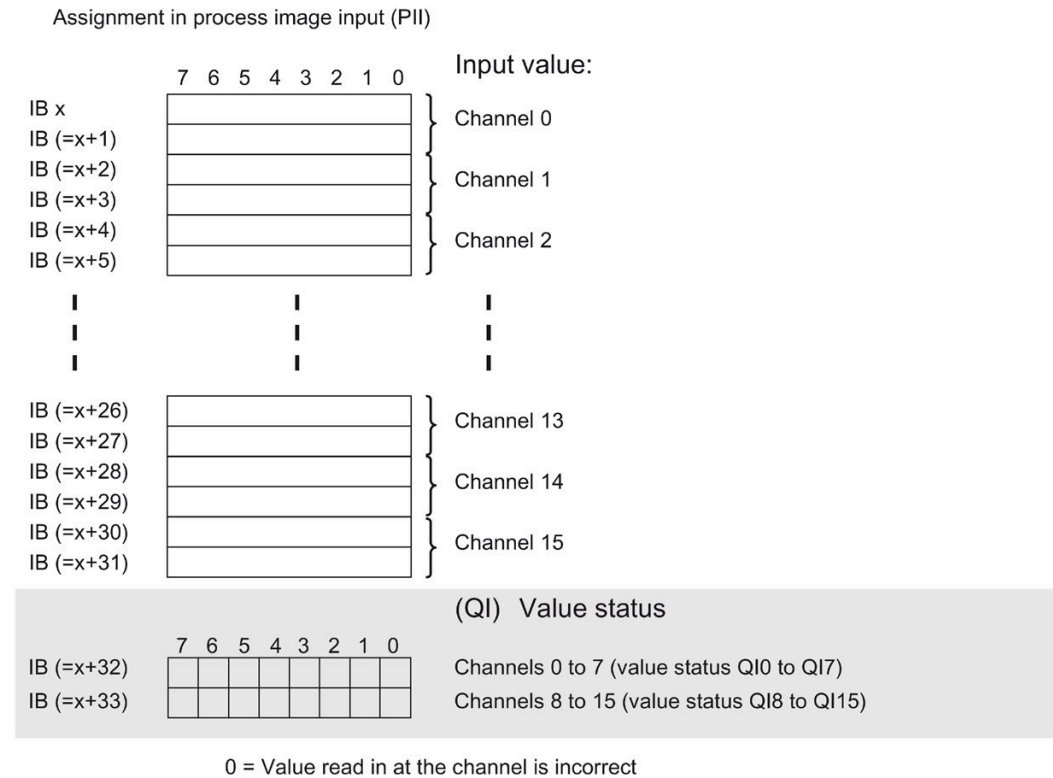

Figure 4-2 Address space for configuration as 1 x 16-channel AI 16xl BA with value status

Address space for configuration as 1 x 16-channel AI 16xl BA MSI

The channels 0 to 15 of the module are copied in up to four submodules with configuration 1 x 16-channel module (module-internal shared input, MSI). Channels 0 to 15 are then available with identical input values in different submodules. These submodules can be assigned to up to four IO controllers when the module is used in a shared device. Each IO controller has read access to the same channels.

The number of usable IO controllers depends on the interface module used. Please observe the information in the manual for the particular interface module.

Value status (Quality Information, QI)

The meaning of the value status depends on the submodule on which it occurs.

For the first submodule (=basic submodule), the value status 0 indicates that the value is incorrect.

For the 2nd to 4th submodule (=MSI submodule), the value status 0 indicates that the value is incorrect or the basic submodule has not yet been configured (not ready).

The following figure shows the assignment of the address space with submodule 3 and 4.

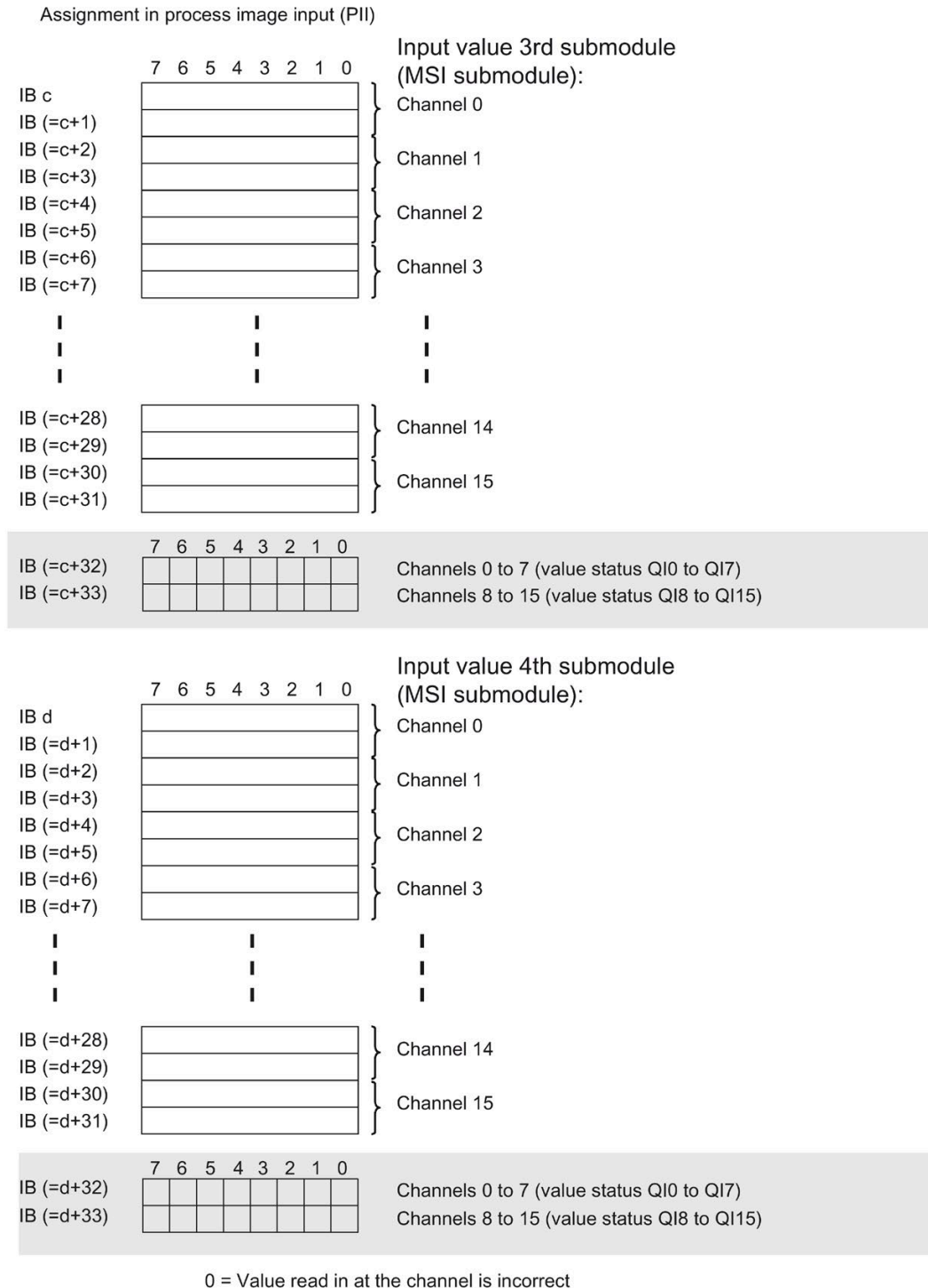

Figure 4-4 Address space for configuration as 1 x 16-channel AI 16xl BA MSI with value status

Reference

You can find information on the Shared Input/Output (MSI/MSO) function in the section Module-Internal Shared Input/Output (MSI/MSO) of the PROFINET with STEP 7 V16 (<https://support.industry.siemens.com/cs/ww/en/view/49948856>) function manual.

Interrupts/diagnostics alarms

5.1 Status and error displays

LED displays

The figure below shows the LED displays (status and error displays) of AI 16xl BA.

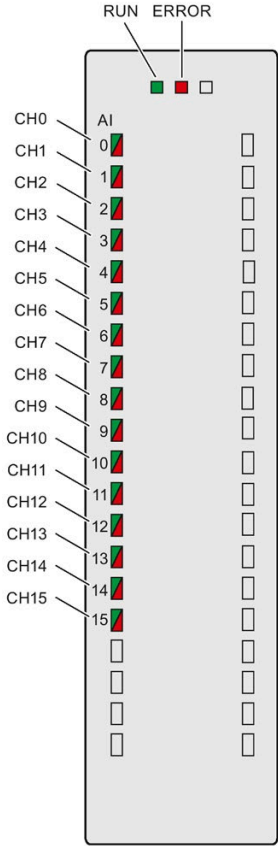











Figure 5-1 LED displays of the AI 16xl BA module

Meaning of the LED displays

The following tables explain the meaning of the status and error displays. Remedial measures for diagnostic alarms can be found in section Diagnostic alarms (Page 27).



RUN and ERROR LED

Table 5- 1 Status and error displays RUN and ERROR

LEDs		Meaning	Remedy
RUN	ERROR		
 Off	 Off	Voltage missing or too low at backplane bus.	<ul style="list-style-type: none"> Switch on the CPU and/or the system power supply modules. Verify that the U connectors are inserted. Check whether too many modules are inserted.
 Flashes	 Off	The module starts and flashes until the valid parameter assignment is set.	---
 On	 Off	Module is configured.	---
 On	 Flashes	Indicates module errors (at least one error at one channel, e.g., wire break).	Evaluate the diagnostics data and eliminate the error (e.g., wire break).
 Flashes	 Flashes	Hardware defective.	Replace the module.

CHx LED

Table 5- 2 CHx status display

LED CHx/COMP	Meaning	Remedy
 Off	Channel disabled	---
 On	Channel configured and OK.	---
 On	Channel is configured (channel error pending). Diagnostic alarm: e.g. wire break	Check the wiring. Disable diagnostics.

5.2 Interrupts

Analog input module AI 16xI BA supports the following diagnostic and hardware interrupts.

You can find detailed information on the event in the error organization block with the "RALRM" instruction (read additional interrupt info) and in the STEP 7 online help.

Diagnostic interrupt

The module generates a diagnostic interrupt at the following events:

- Wire break
- Overflow
- Underflow
- Common mode error
- Parameter assignment error

Hardware interrupt

The module generates a hardware interrupt at the following events:

- Low limit violated 1
- High limit violated 1
- Low limit violated 2
- Above high limit 2

The module channel that triggered the hardware interrupt is entered in the start information of the organization block. The diagram below shows the assignment to the bits of double word 8 in local data.

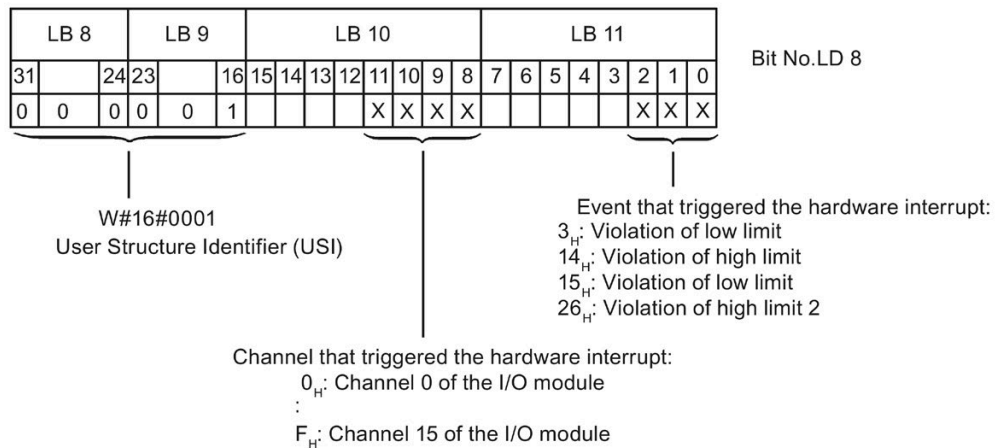

Figure 5-2 OB start information

Reaction when reaching limits 1 and 2 at the same time

If the two high limits 1 and 2 are reached at the same time, the module always signals the hardware interrupt for high limit 1 first. The configured value for high limit 2 is irrelevant. After processing the hardware interrupt for high limit 1, the module triggers the hardware interrupt for high limit 2.

The module has the same reaction when the low limits are reached at the same time. If the two low limits 1 and 2 are reached at the same time, the module always signals the hardware interrupt for low limit 1 first. After processing the hardware interrupt for low limit 1, the module triggers the hardware interrupt for low limit 2.

Structure of the additional interrupt information

Table 5- 3 Structure of USI = W#16#0001

Data block name	Contents	Remark	Bytes
USI (User Structure Identifier)	W#16#0001	Additional interrupt info for hardware interrupts of the I/O module	2
The channel that triggered the hardware interrupt follows.			
Channel	B#16#00 to B#16#n	Number of the event-triggering channel (n = number of module channels -1)	1
The event that triggered the hardware interrupt follows.			
Event	B#16#03	Low limit violated 1	1
	B#16#04	High limit violated 1	
	B#16#05	Low limit violated 2	
	B#16#06	Violation of high limit 2	

5.3 Diagnostics alarms

A diagnostics alarm is generated and the ERROR LED flashes on the module for each diagnostics event. The diagnostics alarms can be read out in the diagnostics buffer of the CPU, for example. You can evaluate the error codes with the user program.

If the module is operated distributed with PROFIBUS DP in an ET 200MP system, you have the option to read out diagnostics data with the instruction RDREC or RD_REC using data record 0 and 1. The structure of the data records is available in the "Manual for interface module IM 155-5 DP ST (6ES7155-5BA00-0AB0)" on the Internet (<https://support.industry.siemens.com/cs/ww/en/view/78324181>).

Table 5- 4 Diagnostics alarms, their meaning and corrective measures

Diagnostics alarm	Error code	Meaning	Solution
Wire break	6H	Impedance of encoder circuit too high	Use a different encoder type or modify the wiring, for example, using cables with larger cross-section
		Wire break between the module and sensor	Connect the cable
		Channel not connected (open)	<ul style="list-style-type: none"> • Disable diagnostics • Connect the channel
Overflow	7H	Measuring range violated	Check the measuring range
Underflow	8H	Measuring range violated	Check the measuring range
Parameter assignment error	10H	<ul style="list-style-type: none"> • The module cannot evaluate parameters for the channel • Incorrect parameter assignment 	Correct the parameter assignment
Common mode error	118H	Valid common mode voltage exceeded	Check the wiring, e.g. sensor ground connections, use equipotential cables

Diagnostics alarms with value status (QI)

If you configure the module with value status (QI), the module always checks all errors even if the respective diagnostics is not enabled. But the module cancels the inspection as soon as it detects the first error, regardless if the respective diagnostics has been enabled or not. The result may be that enabled diagnostics may not be displayed.

Example: You have enabled "Underflow" diagnostics, but the module detects the "Wire break" diagnostics first and aborts after this error message. The "Underflow" diagnostics is not detected.

Recommendation: To ensure that all errors can be diagnosed reliably, select all check boxes under "Diagnostics".

Technical specifications

Technical specifications of AI 16xI BA

The following table shows the technical specifications as of 09/2020. You can find a data sheet including daily updated technical specifications on the Internet (<https://support.industry.siemens.com/cs/ww/en/ps/td>).

Enter the article number or the short designation of the module on the website.

Article number	6ES7531-7MH00-0AB0
General information	
Product type designation	AI 16xI BA
HW functional status	FS01
Firmware version	V1.0.0
• FW update possible	Yes
Product function	
• I&M data	Yes; I&M0 to I&M3
• Prioritized startup	No
Engineering with	
• STEP 7 TIA Portal configurable/integrated from version	V16 with HSP 312 / V17
• STEP 7 configurable/integrated from version	V5.5 SP3 / -
• PROFIBUS from GSD version/GSD revision	V1.0 / V5.1
• PROFINET from GSD version/GSD revision	V2.3 / -
Operating mode	
• Oversampling	No
• MSI	Yes
CiR - Configuration in RUN	
Reparameterization possible in RUN	Yes
Calibration possible in RUN	No
Power	
Power available from the backplane bus	0.85 W
Power loss	
Power loss, typ.	1.2 W
Analog inputs	
Number of analog inputs	16
• For current measurement	16
permissible input current for current input (destruction limit), max.	40 mA

Article number	6ES7531-7MH00-0AB0
Input ranges (rated values), currents	
<ul style="list-style-type: none"> • 0 to 10 mA 	No
<ul style="list-style-type: none"> • 0 to 20 mA <ul style="list-style-type: none"> – Input resistance (0 to 20 mA) 	Yes 25 Ω; Plus approx. 42 ohms for overvoltage protection by PTC
<ul style="list-style-type: none"> • -20 mA to +20 mA <ul style="list-style-type: none"> – Input resistance (-20 mA to +20 mA) 	Yes 25 Ω; Plus approx. 42 ohms for overvoltage protection by PTC
<ul style="list-style-type: none"> • 4 mA to 20 mA <ul style="list-style-type: none"> – Input resistance (4 mA to 20 mA) 	Yes 25 Ω; Plus approx. 42 ohms for overvoltage protection by PTC
Cable length	
<ul style="list-style-type: none"> • shielded, max. 	800 m
Analog value generation for the inputs	
Measurement principle	integrating
Integration and conversion time/resolution per channel	
<ul style="list-style-type: none"> • Resolution with overrange (bit including sign), max. 	16 bit
<ul style="list-style-type: none"> • Integration time, parameterizable 	Yes
<ul style="list-style-type: none"> • Integration time (ms) 	2,5 / 16,67 / 20 / 100 ms
<ul style="list-style-type: none"> • Basic conversion time, including integration time (ms) 	10 / 24 / 27 / 107 ms
<ul style="list-style-type: none"> • Interference voltage suppression for interference frequency f1 in Hz 	400 / 60 / 50 / 10 Hz
Smoothing of measured values	
<ul style="list-style-type: none"> • parameterizable 	Yes
<ul style="list-style-type: none"> • Step: None 	Yes
<ul style="list-style-type: none"> • Step: low 	Yes
<ul style="list-style-type: none"> • Step: Medium 	Yes
<ul style="list-style-type: none"> • Step: High 	Yes
Encoder	
Connection of signal encoders	
<ul style="list-style-type: none"> • for current measurement as 2-wire transducer 	Yes; with external supply
<ul style="list-style-type: none"> • for current measurement as 4-wire transducer 	Yes

Article number	6ES7531-7MH00-0AB0
Errors/accuracies	
Linearity error (relative to input range), (+/-)	0.1 %
Temperature error (relative to input range), (+/-)	0.006 %/K
Crosstalk between the inputs, max.	-50 dB
Repeat accuracy in steady state at 25 °C (relative to input range), (+/-)	0.1 %
Operational error limit in overall temperature range	
• Current, relative to input range, (+/-)	0.5 %
Basic error limit (operational limit at 25 °C)	
• Current, relative to input range, (+/-)	0.3 %
Interference voltage suppression for $f = n \times (f1 \pm 1 \%)$, $f1 =$ interference frequency	
• Series mode interference (peak value of interference < rated value of input range), min.	40 dB
• Common mode voltage, max.	4 V
• Common mode interference, min.	60 dB
Interrupts/diagnostics/status information	
Diagnostics function	Yes
Alarms	
• Diagnostic alarm	Yes
• Limit value alarm	Yes; two upper and two lower limit values in each case
Diagnoses	
• Monitoring the supply voltage	No
• Wire-break	Yes; Only for 4 ... 20 mA
• Short-circuit	No
• Group error	No
• Overflow/underflow	Yes
Diagnostics indication LED	
• RUN LED	Yes; green LED
• ERROR LED	Yes; red LED
• MAINT LED	No
• Monitoring of the supply voltage (PWR-LED)	No
• Channel status display	Yes; green LED
• for channel diagnostics	Yes; red LED
• for module diagnostics	Yes; red LED

Article number	6ES7531-7MH00-0AB0
Potential separation	
Potential separation channels	
<ul style="list-style-type: none"> • between the channels 	No
<ul style="list-style-type: none"> • between the channels, in groups of 	16
<ul style="list-style-type: none"> • between the channels and backplane bus 	Yes
Permissible potential difference	
between the inputs (UCM)	8 V DC
Between the inputs and MANA (UCM)	4 V DC
Isolation	
Isolation tested with	707 V DC (type test)
Ambient conditions	
Ambient temperature during operation	
<ul style="list-style-type: none"> • horizontal installation, min. 	-30 °C; No condensation
<ul style="list-style-type: none"> • horizontal installation, max. 	60 °C
<ul style="list-style-type: none"> • vertical installation, min. 	-30 °C; No condensation
<ul style="list-style-type: none"> • vertical installation, max. 	40 °C
Altitude during operation relating to sea level	
<ul style="list-style-type: none"> • Installation altitude above sea level, max. 	5 000 m; Restrictions for installation altitudes > 2 000 m, see manual
Dimensions	
Width	35 mm
Height	147 mm
Depth	129 mm
Weights	
Weight, approx.	250 g

A

Dimensional drawing

The dimensional drawing of the module on the mounting rail, as well as a dimensional drawing with open front panel are provided in the appendix. Always adhere to the specified dimensions for installations in cabinets, control rooms, etc.

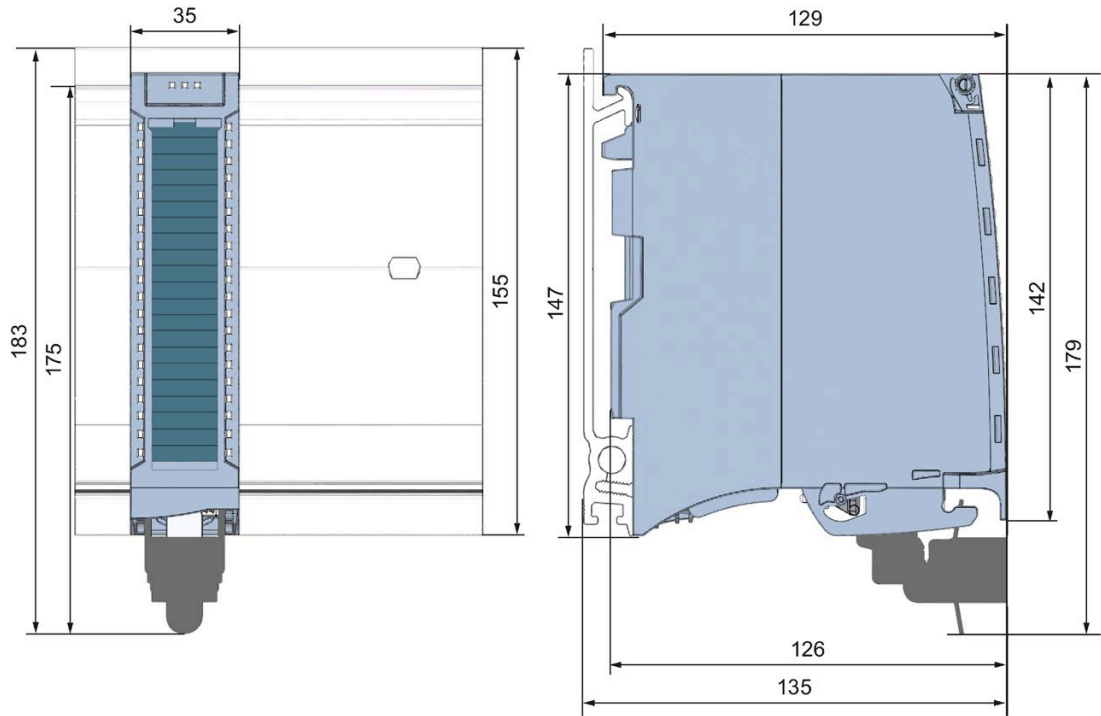

Figure A-1 Dimensional drawing of the AI 16xI BA module



Figure A-2 Dimensional drawing of the AI 16xI BA module, side view with open front cover

Parameter data records

B.1 Parameter assignment and structure of the parameter data records

The data records of the module have an identical structure, regardless of whether you configure the module with PROFIBUS DP or PROFINET IO.

Dependencies for configuration with GSD file

When configuring the module with a GSD file, remember that the settings of some parameters are dependent on each other. The parameters are only checked for plausibility by the module after the transfer to the module.

The following table lists the parameters that depend on one another.

Table B- 1 Dependencies of parameters for configuration with GSD file

Device-specific parameters (GSD file)	Dependent parameters
Wire break	Only for current with measuring range 4 mA to 20 mA.
Hardware interrupt limits	Only if hardware interrupts are enabled.

Parameter assignment in the user program

The module parameters can be assigned in RUN (for example, measuring ranges of selected channels can be edited in RUN without having an effect on the other channels).

Parameter assignment in RUN

The WRREC instruction is used to transfer the parameters to the module using data records 0 to 15. The parameters set in STEP 7 do not change in the CPU, which means the parameters set in STEP 7 are still valid after a restart.

The parameters are only checked for plausibility by the module after the transfer to the module.

Output parameter STATUS

The module ignores errors that occurred during the transfer of parameters with the WRREC instruction and continues operation with the previous parameter assignment. However, a corresponding error code is written to the STATUS output parameter.

The description of the WRREC instruction and the error codes is available in the STEP 7 online help.

Operation of the module behind a PROFIBUS DP interface module

If the module is operated behind a PROFIBUS DP interface module, the parameter data records 0 and 1 are not read back. You obtain the diagnostics data records 0 and 1 with the read back parameter data records 0 and 1. You can find additional information in the Interrupts section of the manual for the PROFIBUS DP interface module on the Internet (<http://support.automation.siemens.com/WW/view/en/78324181>).

Assignment of data record and channel

For the configuration with 1 x 16-channel, the parameters are located in data records 0 to 15 and are assigned as follows:

- Data record 0 for channel 0
- Data record 1 for channel 1
- ...
- Data record 14 for channel 14
- Data record 15 for channel 15

Data record structure

The figure below shows the structure of data record 0 for channel 0 as an example. The structure is identical for channels 1 to 15. The values in byte 0 and byte 1 are fixed and may not be changed.

Enable a parameter by setting the corresponding bit to "1".

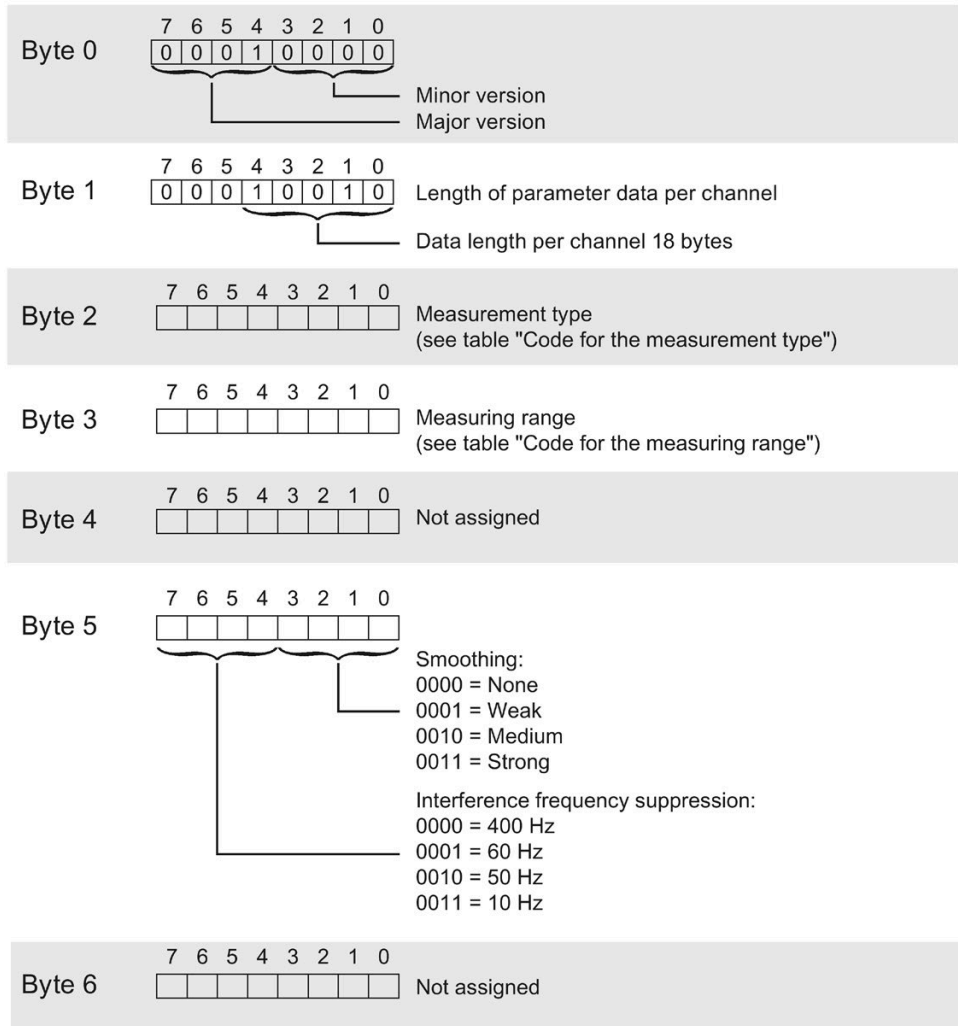
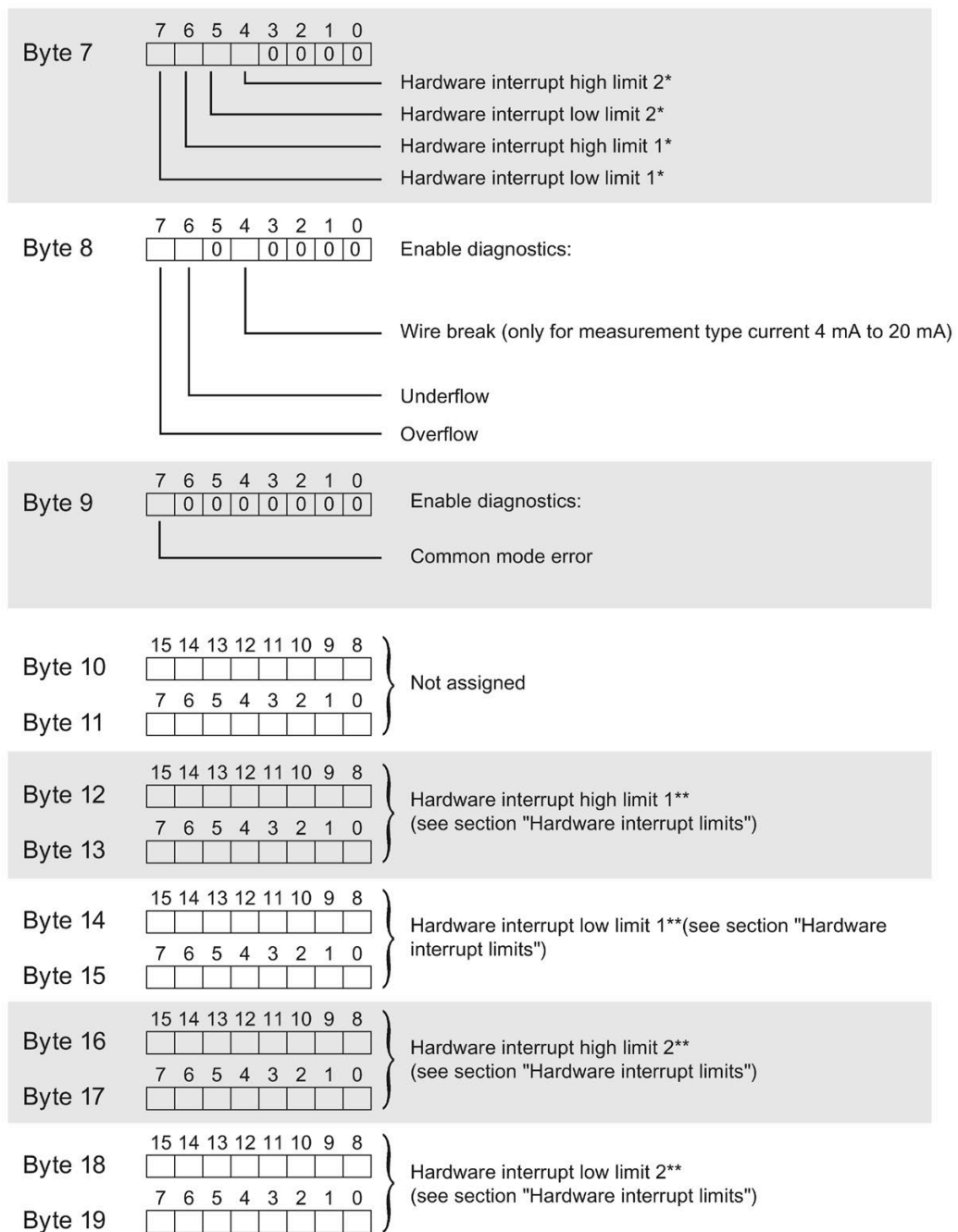

Figure B-1 Structure of data record 0: Bytes 0 to 6

B.1 Parameter assignment and structure of the parameter data records



* Hardware interrupts can only be activated via data record if the channel is assigned a hardware interrupt OB in STEP 7

** High limit must be greater than low limit

Figure B-2 Structure of data record 0: Bytes 7 to 19

Codes for measurement types

The following table lists all measurement types of the analog input module along with their codes. Enter these codes at byte 2 of the data record for the corresponding channel (see the figure Structure of data record 0: Bytes 7 to 19).

Table B- 2 Code for the measurement type

Measurement type	Code
Deactivated	0000 0000
Current, 2-wire transmitter	0000 0011
Current, 4-wire transmitter	0000 0010

Codes for measuring ranges

The following table lists all measuring ranges of the analog input module along with their codes. Enter these codes accordingly at byte 3 of the data record for the corresponding channel (see the figure Structure of data record 0: Bytes 7 to 19).

Table B- 3 Code for the measuring range

Measuring range	Code
Current, 4-wire transmitter	
0 mA to 20 mA	0000 0010
4 mA to 20 mA	0000 0011
±20 mA	0000 0100
Current, 2-wire transmitter	
4 mA to 20 mA	0000 0011

Hardware interrupt limits

The values that you can set for hardware interrupts (high/low limit) must not violate the over/underrange of the respective rated measuring range.

The following tables list the valid hardware interrupt limits. The limits depend on the selected measurement type and measuring range.

Table B- 4 Current limits

Current		
±20 mA	4 mA to 20 mA / 0 mA to 20 mA	
32510	32510	High limit
-32511	-4863	Low limit

Representation of analog values

Introduction

This appendix shows the analog values for all measuring ranges supported by the AI 16xI BA analog module.

Measured value resolution

Each analog value is written left aligned to the tags. The bits marked with "x" are set to "0".

Table C- 1 Resolution of the analog values

Resolution in bits including sign	Values		Analog value	
	Decimal	Hexadecimal	High byte	Low byte
16	1	1H	Sign 0 0 0 0 0 0 0	0 0 0 0 0 0 0 1

C.1 Representation of input ranges

The tables below set out the digitized representation of the input ranges separately for bipolar and unipolar input ranges. The resolution is 16 bits.

Table C- 2 Bipolar input ranges

Dec. value	Measured value in %	Data word															Range	
		2 ¹⁵	2 ¹⁴	2 ¹³	2 ¹²	2 ¹¹	2 ¹⁰	2 ⁹	2 ⁸	2 ⁷	2 ⁶	2 ⁵	2 ⁴	2 ³	2 ²	2 ¹		2 ⁰
32767	>117.589	0	1	1	1	1	1	1	1	1	1	1	1	1	1	1	1	Overflow
32511	117.589	0	1	1	1	1	1	1	0	1	1	1	1	1	1	1	1	Overshoot range
27649	100.004	0	1	1	0	1	1	0	0	0	0	0	0	0	0	0	1	
27648	100.000	0	1	1	0	1	1	0	0	0	0	0	0	0	0	0	0	Rated range
1	0.003617	0	0	0	0	0	0	0	0	0	0	0	0	0	0	0	1	
0	0.000	0	0	0	0	0	0	0	0	0	0	0	0	0	0	0	0	
-1	-0.003617	1	1	1	1	1	1	1	1	1	1	1	1	1	1	1	1	
-27648	-100.000	1	0	0	1	0	1	0	0	0	0	0	0	0	0	0	0	Undershoot range
-27649	-100.004	1	0	0	1	0	0	1	1	1	1	1	1	1	1	1	1	
-32512	-117.593	1	0	0	0	0	0	0	1	0	0	0	0	0	0	0	0	Underflow
-32768	<-117.593	1	0	0	0	0	0	0	0	0	0	0	0	0	0	0	0	

Table C- 3 Unipolar input ranges

Dec. value	Measured value in %	Data word															Range	
		2 ¹⁵	2 ¹⁴	2 ¹³	2 ¹²	2 ¹¹	2 ¹⁰	2 ⁹	2 ⁸	2 ⁷	2 ⁶	2 ⁵	2 ⁴	2 ³	2 ²	2 ¹		2 ⁰
32767	>117.589	0	1	1	1	1	1	1	1	1	1	1	1	1	1	1	1	Overflow
32511	117.589	0	1	1	1	1	1	1	0	1	1	1	1	1	1	1	1	Overshoot range
27649	100.004	0	1	1	0	1	1	0	0	0	0	0	0	0	0	0	1	
27648	100.000	0	1	1	0	1	1	0	0	0	0	0	0	0	0	0	0	Nominal range
1	0.003617	0	0	0	0	0	0	0	0	0	0	0	0	0	0	0	1	
0	0.000	0	0	0	0	0	0	0	0	0	0	0	0	0	0	0	0	
-1	-0.003617	1	1	1	1	1	1	1	1	1	1	1	1	1	1	1	1	Undershoot range
-4864	-17.593	1	1	1	0	1	1	0	1	0	0	0	0	0	0	0	0	
-32768	<-17.593	1	0	0	0	0	0	0	0	0	0	0	0	0	0	0	0	Underflow

C.2 Representation of analog values in the current measuring ranges

The following tables list the decimal and hexadecimal values (codes) of the possible current measuring ranges.

Table C- 4 Current measuring range ± 20 mA

Values		Current measuring range	
dec	hex	± 20 mA	
32767	7FFF	>23.52 mA	Overflow
32511	7EFF	23.52 mA	Overshoot range
27649	6C01		
27648	6C00	20 mA	Rated range
20736	5100	15 mA	
1	1	723.4 nA	
0	0	0 mA	
-1	FFFF		
-20736	AF00	-15 mA	
-27648	9400	-20 mA	
-27649	93FF		Undershoot range
-32512	8100	-23.52 mA	
-32768	8000	< -23.52 mA	Underflow

Table C- 5 Current measuring ranges 0 to 20 mA and 4 to 20 mA

Values		Current measuring range		
dec	hex	0 to 20 mA	4 to 20 mA	
32767	7FFF	>23.52 mA	>22.81 mA	Overflow
32511	7EFF	23.52 mA	22.81 mA	Overshoot range
27649	6C01			
27648	6C00	20 mA	20 mA	Rated range
20736	5100	15 mA	16 mA	
1	1	723.4 nA	4 mA + 578.7 nA	
0	0	0 mA	4 mA	
-1	FFFF			
-4864	ED00	-3.52 mA	1.185 mA	Undershoot range
-32768	8000	<- 3.52 mA	< 1.185 mA	
				Underflow

C.3 Measured values for wire break diagnostic

Measured values on diagnostic event "wire break", dependent on diagnostics enables

Error events initiate a diagnostics entry and trigger a diagnostics interrupt if configured accordingly.

Table C- 6 Measured values for wire break diagnostic

Format	Parameter assignment	Measured values		Explanation
S7	<ul style="list-style-type: none"> "Wire break" diagnostics enabled "Overflow/Underflow" diagnostics enabled or disabled ("Wire break" diagnostics takes priority over "Overflow/Underflow" diagnostics)	32767	7FFF _H	"Wire break" or "Open circuit" diagnostic alarm
	<ul style="list-style-type: none"> "Wire break" diagnostics disabled "Overflow/Underflow" diagnostics enabled 	-32768	8000 _H	<ul style="list-style-type: none"> Measured value after leaving the undershoot range Diagnostic alarm "Low limit violated"
	<ul style="list-style-type: none"> "Wire break" diagnostics disabled "Overflow/Underflow" diagnostics disabled 	-32768	8000 _H	Measured value after leaving the undershoot range