

service & SUPPORT

**Explanation about the Order No. of the new 1LE1
generation of aluminium motors**

SIEMENS

IEC motors 1LE1

Warranty, liability and support

We do not accept any liability for the information contained in this document.

Any claims against us - based on whatever legal reason - resulting from the use of the examples, information, programs, engineering and performance data etc., described in this example shall be excluded. Such an exclusion shall not apply in the case of mandatory liability, e.g. under the German Product Liability Act ("Produkthaftungsgesetz"), in case of intent, gross negligence, or injury of life, body or health, guarantee for the quality of a product, fraudulent concealment of a deficiency or breach of a condition which goes to the root of the contract ("wesentliche Vertragspflichten"). However, claims arising from a breach of a condition which goes to the root of the contract shall be limited to the foreseeable damage which is intrinsic to the contract, unless caused by intent or gross negligence or based on mandatory liability for injury of life, body or health. The above provisions does not imply a change in the burden of proof to your detriment.

Copyright© 2007 Siemens A&D. It is not permissible to transfer or copy these examples or excerpts of them without first having prior authorization from Siemens A&D in writing.

For suggestions about this document please use the following e-mail address:

<mailto:sdsupport.aud@siemens.com>

Table of Contents

Table of Contents	3
1 Overview	4
2 The 16-position motor MLFB – an overview	5
3 The MLFB structure in detail	7
3.1 MLFB positions 1 – 3	7
3.2 MLFB position 4	7
3.3 MLFB positions 5 – 7	8
3.4 MLFB positions 8,9 & 11	8
3.5 MLFB position 10	9
3.6 MLFB positions 12 & 13	9
3.7 MLFB position 14	10
3.8 MLFB position 15	11
3.9 MLFB position 16	11
4 Z options – basic logic	12
MLFB rule for options	12
5 Appendix	14
5.1 Internet links	14
5.2 History	14

This entry is from the Internet offer of Siemens AG, Automation and Drives, Service & Support. Clicking the link below directly displays the download page of this document.

<http://support.automation.siemens.com/WW/view/en/26284803>

1 Overview

One of the basic rules that applies to MLFBs (Order Nos.) is the uniqueness and clarity of the description.

An Order No. [MLFB] structure had to be found for the new motor generations that not only maps the series to be currently launched, but also all future versions and their derivatives – and that in all of the necessary versions.

Unfortunately almost all possibilities of making a differentiation in the first three positions of the MLFB were already occupied. This is the reason that all new motor generations from SD – with the exception of the ATEX versions – will in the future start with 1LE.

The new motor MLFB code has 16 positions – comprising letters and digits – and is described in the MLFB rules & regulations.

The most important changes to the “old” MLFB relate to positions 4 to 7 of the MLFB as well as to the Z options.

- Positions 4 to 7 are now pure numerical positions (digits only) and are no longer available to designate the shaft heights.
- It was absolutely necessary to make some essential changes in designating the Z options. This meant that there was no longer any free spaces in the existing option trees and for the 1LE1 series, the options have been re-structured and defined. The new MLFB structure allows essential Z options of today to be directly mapped in the MLFB in the future.

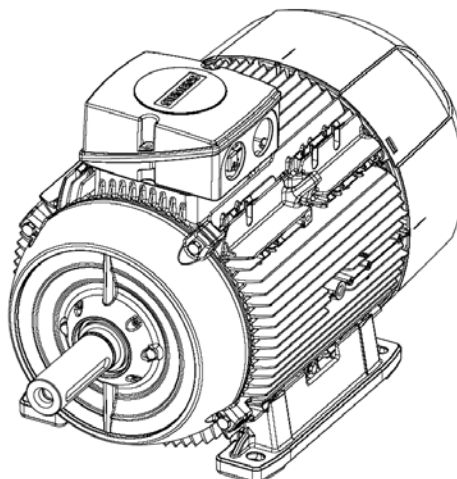

Existing motor series will not be assigned new MLFBs

A transcoding can be carried out via the Karalog CA01.

2 The 16-position motor MLFB – an overview

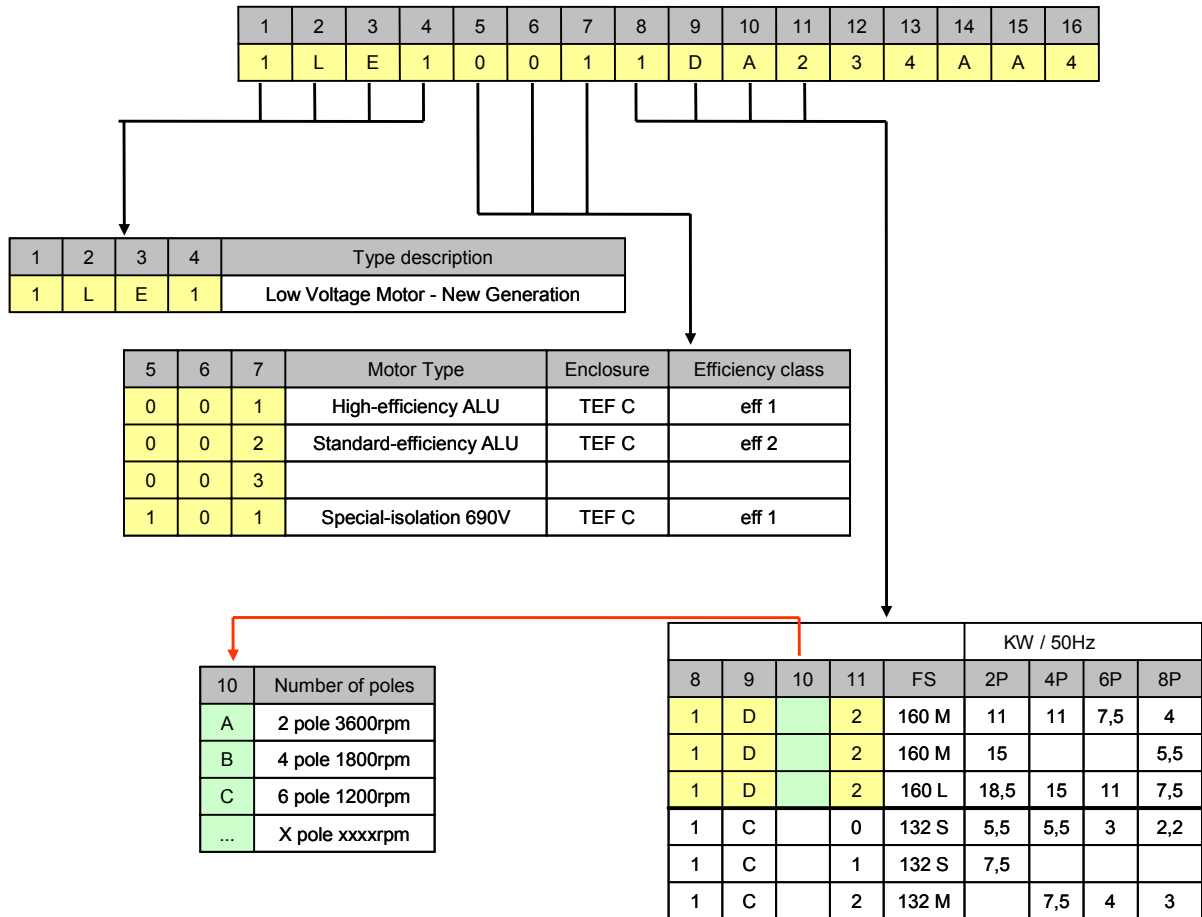

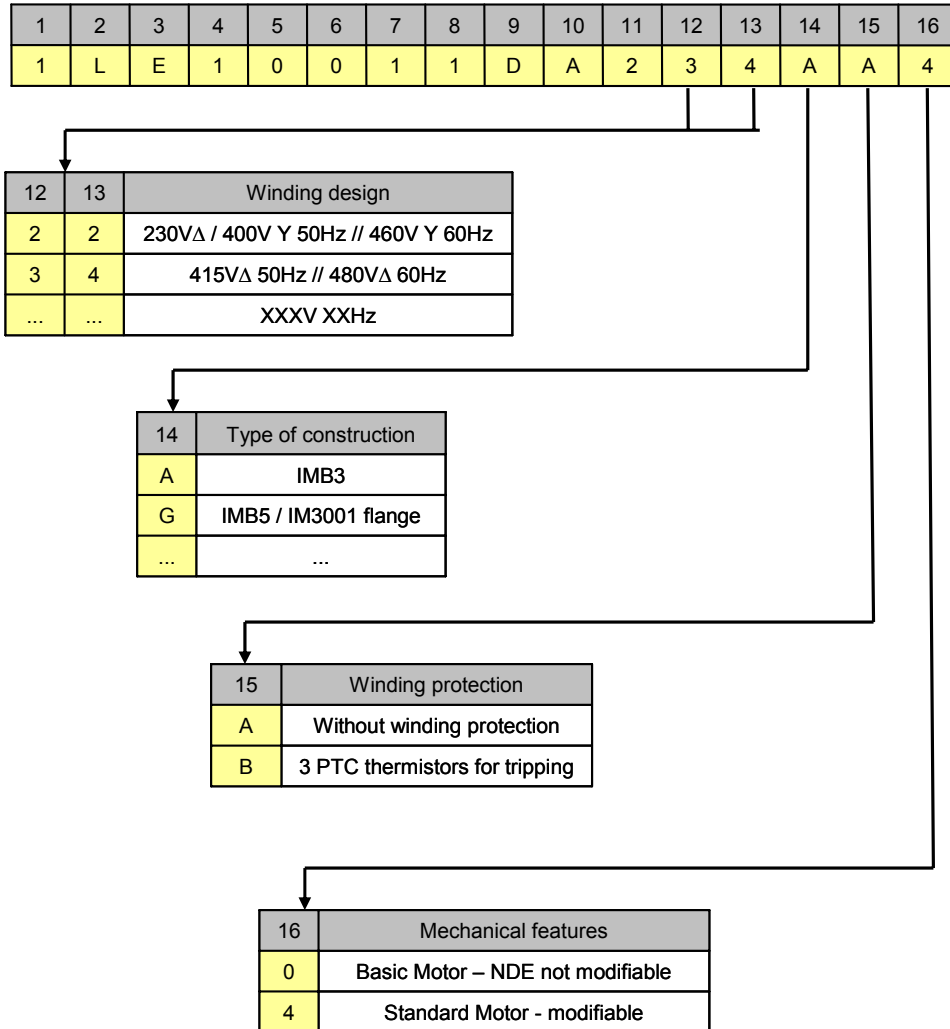

3 The MLFB structure in detail

To start, a basic explanation.

The 16-position MLFB comprises both numerical as well as also alphanumerical positions that are incremented; their significance and assignment are explained in the guidelines on the MLFB structure.

Definition	N	A	A	N	N	N	N		N	A	A	N	N		N	A	A	N
Numbering	1	2	3	4	5	6	7		8	9	10	11	12		13	14	15	16
MLFB (order no.)	1	L	E	1	0	0	1	-	1	A	A	4	3	-	4	B	A	4
	A = Letter							N = Number										

Table 3-1

The individual positions will now be explained in more detail.

3.1 MLFB positions 1 – 3

The main series of the motor series are coded in positions 1-3.

1	L	E	1	0	0	1	-	1	A	A	4	3	-	4	B	A	4
position in the MLFB	1	2	3														
	N	A	A	definition													
	1	L	E	Low-voltage motors/ standard type													
	1	M	B	Motors for specific ambient conditions (for example Ex-motors)													
	1	P	C	Special motors/ custom motors													

Table 3-2

3.2 MLFB position 4

The secondary series of the motor series are coded in position 4.

1	L	E	1	0	0	1	-	1	A	A	4	3	-	4	B	A	4
Position in the MLFB	4																
	N	Definition															
	1	New IEC motor series in aluminum															
	2	New NEMA motor series in aluminum															

Table 3-3

3.3 MLFB positions 5 – 7

The voltage, efficiency and the country code of the motor series is coded in positions 5-7.

1	L	E	1	0	0	1	-	1	A	A	4	3	-	4	B	A	4
position in the MLFB						5	6	7									
						N	N	N	definition								
Design, version, country series for example IEC ALU eff1/eff2, IEC GG eff1, motor for gears for Brazil, for Taiwan, for Australia																	
						0	0	1	High-efficiency (EU eff1) ALU								
						0	0	2	Standard-efficiency (EU eff2) ALU								
						0	4	1	"Country", Standard-efficiency eff2, ALU								

Table 3-4

3.4 MLFB positions 8,9 & 11

The shaft height and core length of the series are coded in positions 8,9 & 11. Whereby "0" stands for SH less than 100 and "1" etc. stands for SH greater than 100.

1	L	E	1	0	0	1	-	1	A	A	4	3	-	4	B	A	4
position in the MLFB						8	9	11									
						N	A	N									
IEC shaft heights FS 0																	
						0	A	2	FS056		(2,...,6)						
						0	B	2	FS063		(2,...,6)						
						0	C	2	FS071		(2,...,6)						
						0	D	2	FS080		(2,...,6)						
						0	E	1	FS090		(0,...,6)						
IEC shaft heights FS 1																	
						1	A	3	FS100		(4,...,6)						
						1	B	2	FS112		(2,...,6)						
						1	C	1	FS132		(0,...,6)						
						1	D	2	FS160		(2,...,6)						
						1	E	2	FS180		(2,...,6)						
IEC shaft heights FS 2																	
						2	A	3	FS200		(4,...,6)						
						2	B	1	FS225		(2,...,6)						
						2	C	2	FS250		(3,...,6)						
						2	D	1	FS280		(2,...,6)						
IEC shaft heights FS 3																	
						3	A	1	FS315		(2,...,6)						

0,1=S
2,3=M
4,5=L
5,6=next higher output

Table 3-5

3.5 MLFB position 10

The pole number of the motor series is coded in position 10.

MLFB position 10th position: number of poles																	
1	L	E	1	0	0	1	-	1	A	A	4	3	-	4	B	A	4
position in the MLFB		10															
		N															
		A		2-pole													
		B		4-pole													
		C		6-pole													
		D		8-pole													
		E		10-pole													
		F		12-pole													
		G		14-pole													
		H		16-pole													
		J		PC4-/2-pole, constant moment													
		K		PC6-/4-pole, constant moment													
		L		PC8-/4-pole, constant moment													
		M		PC8-/6-/4-pole, constant moment													
		N															
		P		PC4-/2-pole, quadratic moment													
		Q		PC6-/4-pole, quadratic moment													
		R		PC8-/4-pole, quadratic moment													
		S		PC8-/6-/4-pole, quadratic moment													

Table 3-6

3.6 MLFB positions 12 & 13

The voltage code of the motor series is coded in positions 12 & 13.

1	L	E	1	0	0	1	-	1	A	A	4	3	-	4	B	A	4
Position i. d. MLFB		12	13														
		N	N	50Hz				60 Hz									
		2	1	220V Δ / 380V Y				440V Y									
		2	2	230V Δ / 400V Y				460V Y									
		2	3	240V Δ / 415V Y				480V Y									
		2	7	500V Y				575V Y									
		3	3	380V Δ / 660V Y				440V Δ									
		3	4	400V Δ / 690V Y				460V Δ									
		4	0	500V Δ				575V Δ									

Table 3-7

3.7 MLFB position 14

The type of constructions of the motor series is coded in position 14.

MLFB position 14th position: frame sizes																	
1	L	E	1	0	0	1	-	1	A	A	4	3	-	4	B	A	4
position in the MLFB	14																
	A																before
	A	IM B3, IM B6, IM B7, IM B8, IM V5, IM V6, stamped IM B3															0
	B																
	C	IM V5 / IM 1011															M1D,M1F
	D	IM V6 / IM 1031															M1E
	E																
	F	IM B5 / IM 3001, IM V1, IM V3, stamped IM B5 flange															1
	G	IM V1 / IM 3011 flange															1,8,4 *)
	H	IM V3 / IM 3031 flange															1, M1G
	I																
	J	IM B35 / IM 2001 flange															6
	K	IM B14 / IM 3601 standard flange															3
	L	IM B14 / IM 3601, IM V19 / IM 363, IM V18 / IM 3611 standard flange															2 M2A, *) 2
	M	IM V18 / IM 3611 standard flange															7
	N	IM B34 / IM 2101 standard flange															7
	O																
	P																
	Q																
	R																
	S																
	T	IM B6 / IM 1051															
	U	IM B7 / IM 1061															
	V	IM B8 / IM 1071															
Z-option																	
	P01	proximate upper flange															
	P02	proximate lower flange															
protective cover																	
	H00	protective cover															

Table 3-8

*) More information under: www.siemens.com/low-voltage-motors

The stamp on the rating plate is made according to the basic type.

Caution:

Condensation water drain holes can only be provided at the correct position if the correct type of construction is ordered.

3.8 MLFB position 15

The winding protection / motor protection of the motor series is coded in position 15.

1	L	E	1	0	0	1	-	1	A	A	4	3	-	4	B	A	4		
position in the MLFB			15																
			A															before	
			A															without winding cover	
			B															3 posistor (cutoff)	A11
			C															6 posistor (warning + cutoff)	A12

Table 3-9

3.9 MLFB position 16

The mechanical design of the motor series is coded in position 16.

1	L	E	1	0	0	1	-	1	A	A	4	3	-	4	B	A	4		
position in the MLFB			16																
			N															before	
			0															General Line, shaft extension NDE or extensibility, terminal box up no Z-option	
			1																
			2																
			3																
			4															standard motor for catalogue options, terminal box up	
			5															standard motor for catalogue options, terminal box right	K09
			6															standard motor for catalogue options, terminal box left	K10
			7															standard motor for catalogue options, terminal box below	A60
			8																

Table 3-10

* General Line

The term General Line designates a motor that is constructed in large batch quantities and is quickly available (is available ex-stock).

Features: The motor version is permanently defined. It is not permissible to extend at the NDE – e.g. using an encoder or mounted brake.

** Standard Motor

A space retainer that stands for all of the motors, with the exception of General Line motors.

4 Z options – basic logic

Many meanings of the Z options change with the new MLFB system.

MLFB rule for options

If there is a Z or a 9 in the MLFB then the position specifies the first letter of the option.

E.g. the 15th position of the MLFB is in this case, Q motor protection
→ Q1A PTC thermistor for alarm (A10)

Additional expansion that cannot be mapped in the MLFB include:

E.g. under motor protection

Q01 measuring nipple for shock pulse measurement (G50)

Short detail	Description
A	open
B	operating mode / others
C	tests and certificates
D	country specific standards, coolant temperature
E	marine standards, coolant temperature
F	accessory equipment, brake and fan
G	accessory equipment, encoder
H	special mechanical design frame
K	number of poles
L	special mechanical design
M	special design for supply voltage
N	special electrical design
P	special design for type of construction
Q	motor protection
R	special mechanical design
S	colour
T	open
U	open

V	reserved for factory
W	reserved for factory
X	reserved for factory
Y	versions for price designing

The new MLFBs and options only apply for the future motor series.

1LE1001 and 1LE1002 represent the start of the new MLFBs and options

An explanation of the differences between the old and new MLFBs is
provided under
http://sd.nes.siemens.de/sales_2003/support/tools/html_76/index.html

5 Appendix

5.1 Internet links

This list is by no means complete and only provides a selection of appropriate sources.

	Topic	Title
\1\	Up Date [INTRANET]	Release for sale and release for general availability for 1LE1 motors, SH 112
\2\	Current [INTRANET]	Release for sale and general availability for 1LE1 shaft height 132 and motors with increased power, shaft height 160
\3\	Current [INTRANET]	Release for sale and release for general availability: IEC-Motors 1LE1 motors, shaft height 160
\4\	Siemens Web Site	Low-Voltage Motors
\5\	Acquisition help [INTRANET]	Foiles
\6\	Index [INTRANET]	http://intranet.siemens.com/sd-index

5.2 History

Table 5-1 History

Version	Date	Changes
V1.0	July 2007	First edition