

## 6.1 NCU terminal block 6FC5211-0AA0-0AA0

**Connection to the drive bus**

The terminal block is connected to connector X20 on the drive bus of the last drive module via round cables. These cables are available in different lengths. (cable lengths 1, 2, 5, and 10 m). Up to 2 terminal blocks can be operated (in accordance with the available NCK addresses for rapid analog and digital I/Os). The round cables are also used in conjunction with individual terminal blocks.

**Important**

Please make sure that the total length of the cable connections does not exceed 10 m.

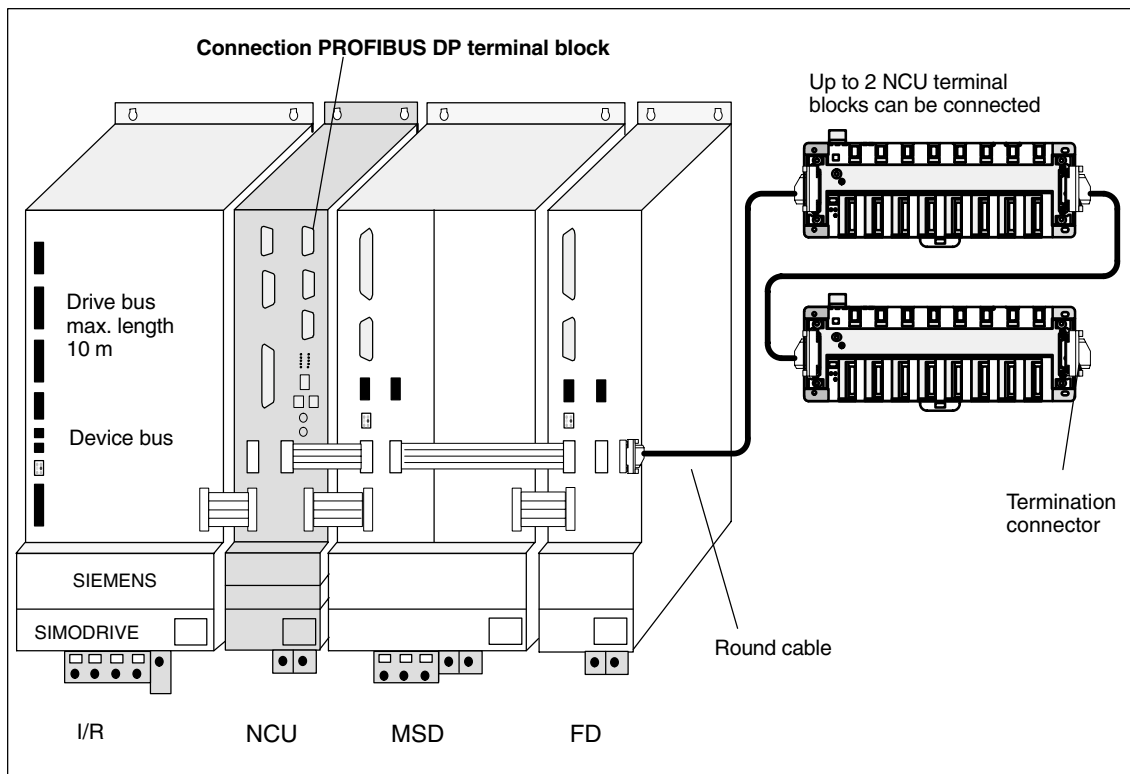

Fig. 6-2 Connection of terminal block to 840D

**Terminator**

The termination connector must be plugged into slot X21 on the last NCU terminal block.

**Protective conductor**

When the PE and interference conductors are in common, the PE conductor rules in EN 61800-5-1 must be followed. PE conductor connection, see Fig. 6-1.