

SIEMENS

Ingenuity for life

Industry Online Support

Home

SIMATIC HMI and OPC UA Part 3: S7-1500 Server, Comfort Panel Client

WinCC Advanced V14, STEP 7 Professional V14

<https://support.industry.siemens.com/cs/ww/en/view/63481236>

Siemens
Industry
Online
Support



Warranty and Liability

Note

The Application Examples are not binding and do not claim to be complete regarding the circuits shown, equipping and any eventuality. The Application Examples do not represent customer-specific solutions. They are only intended to provide support for typical applications. You are responsible for ensuring that the described products are used correctly. These Application Examples do not relieve you of the responsibility to use safe practices in application, installation, operation and maintenance. When using these Application Examples, you recognize that we cannot be made liable for any damage/claims beyond the liability clause described. We reserve the right to make changes to these Application Examples at any time without prior notice.

If there are any deviations between the recommendations provided in these Application Examples and other Siemens publications – e.g. Catalogs – the contents of the other documents have priority.

We do not accept any liability for the information contained in this document. Any claims against us – based on whatever legal reason – resulting from the use of the examples, information, programs, engineering and performance data etc., described in this Application Example shall be excluded. Such an exclusion shall not apply in the case of mandatory liability, e.g. under the German Product Liability Act ("Produkthaftungsgesetz"), in case of intent, gross negligence, or injury of life, body or health, guarantee for the quality of a product, fraudulent concealment of a deficiency or breach of a condition which goes to the root of the contract ("wesentliche Vertragspflichten"). The damages for a breach of a substantial contractual obligation are, however, limited to the foreseeable damage, typical for the type of contract, except in the event of intent or gross negligence or injury to life, body or health. The above provisions do not imply a change of the burden of proof to your detriment.

Any form of duplication or distribution of these Application Examples or excerpts hereof is prohibited without the expressed consent of the Siemens AG.

Security information

Siemens provides products and solutions with industrial security functions that support the secure operation of plants, systems, machines and networks. In order to protect plants, systems, machines and networks against cyber threats, it is necessary to implement – and continuously maintain – a holistic, state-of-the-art industrial security concept. Siemens' products and solutions only form one element of such a concept.

Customer is responsible to prevent unauthorized access to its plants, systems, machines and networks. Systems, machines and components should only be connected to the enterprise network or the internet if and to the extent necessary and with appropriate security measures (e.g. use of firewalls and network segmentation) in place.

Additionally, Siemens' guidance on appropriate security measures should be taken into account. For more information about industrial security, please visit <http://www.siemens.com/industrialsecurity>.

Siemens' products and solutions undergo continuous development to make them more secure. Siemens strongly recommends to apply product updates as soon as available and to always use the latest product versions. Use of product versions that are no longer supported, and failure to apply latest updates may increase customer's exposure to cyber threats.

To stay informed about product updates, subscribe to the Siemens Industrial Security RSS Feed under <http://www.siemens.com/industrialsecurity>.

""

Table of Contents

	Warranty and Liability	2
1	Task.....	4
2	Solution.....	5
	2.1 Overview.....	5
	2.2 Hardware and software components	6
3	Configuration and Project Engineering.....	7
	3.1 Preparation.....	7
	3.2 STEP 7 configuration (server).....	8
	3.3 Comfort Panel configuration (client).....	19
	3.3.1 Creating the certificate	19
	3.3.2 Assigning the PLC certificate to the Comfort Panel	21
	3.3.3 Online browsing to the PLC tags.....	23
	3.3.4 Device name	24
	3.4 Error analysis	24
4	Operation of the Application Example	26
	4.1 Startup.....	26
	4.2 Operation.....	26
5	Links & Literature	29
6	History.....	29

1 Task

Introduction

The application example describes the configuration steps for creating a secure OPC UA connection (UA Security)¹ between a SIMATIC S7-1500 controller and a Comfort Panel.

Overview of the automation task

An HMI operator panel and a PLC are used for machine control. The HMI operator panel communicates with PLC 1 via an HMI connection.

The same operator panel is used to output the machine data of other plant parts. The HMI operator panel receives the data from the plant-related PLC (in this case: PLC 2).

Communication between the HMI operator panel and PLC 2 requires data integrity (authorization and encryption).

The following figure provides an overview of the application example.

Figure 1-1

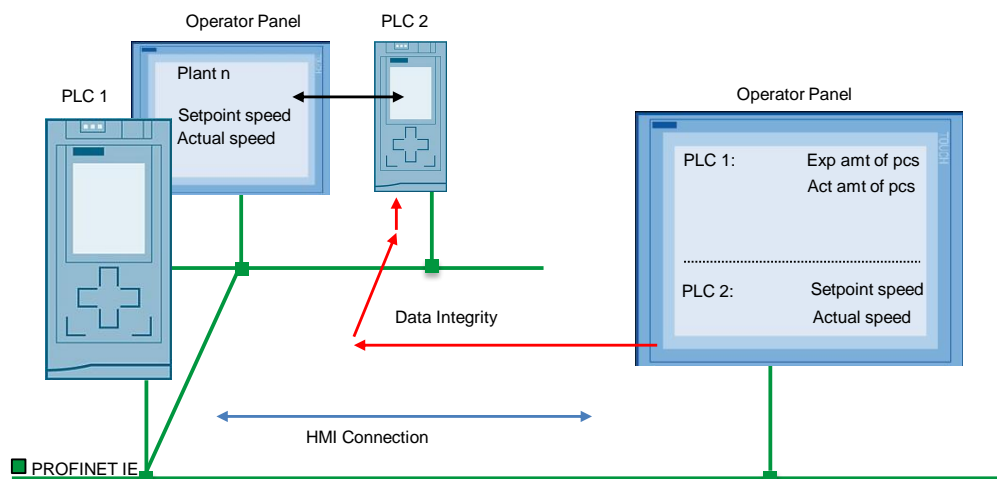

¹ UA Security consists of authentication and authorization, encryption and data integrity via signatures.

2 Solution

2.1 Overview

SIMATIC Comfort Panels and SIMATIC S7-1500 controllers are used to control the plant areas.

The SIMATIC S7-1500 controllers provide data (tags) that is accessed by the Comfort Panel.

The devices are parameterized as follows:

- The Comfort Panel is parameterized as an OPC UA client.
- The SIMATIC S7-1500 controller is parameterized as an OPC UA server.
- The Comfort Panel communicates with the controller (PLC 2) via an OPC UA connection. Data integrity through encryption and digital signatures is supported by the OPC UA communication interface.

Diagrammatic representation

The diagrammatic representation below shows the most important components of the solution:

Figure 2-1

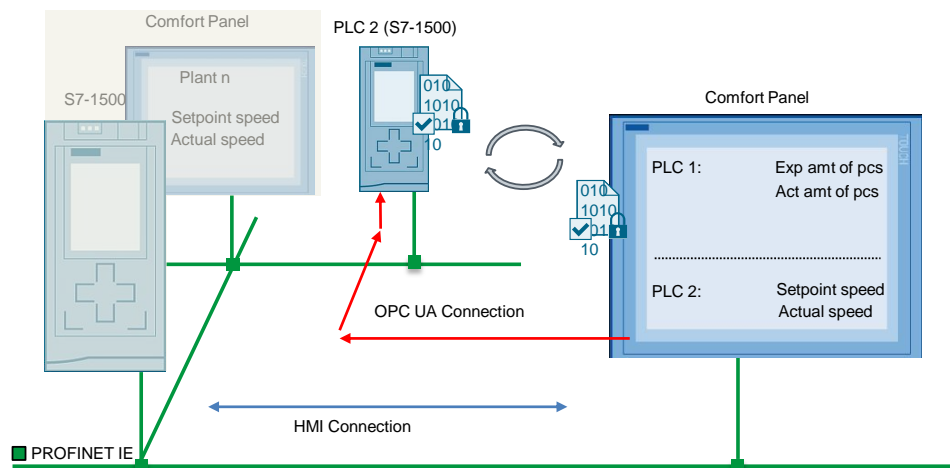

Configuration

All devices are integrated into a PROFINET network. The devices communicate with each other via an HMI connection and the OPC UA interface.

The following devices are used as hardware:

- SIMATIC S7-1516-3PN/DP controller (server)
- SIMATIC HMI TP900 Comfort (client)

Note

The application example describes communication via OPC UA and the implementation of data integrity. Configuring an HMI connection is required.

2.2 Hardware and software components

Validity

This application example is valid for:

- WinCC Advanced V14 or higher.
- Comfort Panels and HMI operator panels that support communication via OPC UA.

Hardware components

Table 2-1

Component	No.	Article number	Note
CPU 1516-3PN/DP	1	6ES7 516-AN01-0AB0	Firmware version V2.0 or higher
TP900 Comfort	1	6AV2 124-0JC01-0AX0	All HMI operator panels that support OPC UA

Software components

Table 2-2

Component	No.	Article number	Note
STEP 7 Professional V14	1	6ES7822-1AA04-0YA7	Or later version
WinCC Comfort V14	1	6AV2101-0AA04-0AH5 6AV2101-0AA04-0AA5	Or later version

Sample files and projects

The following list contains all files and projects that are used in the application example.

Table 2-3

Component	Note
63481236_Part3_CODE_S7-1500_Server_Panel_Client.zip	This zip file contains the STEP 7 and TP900 Comfort project.
63481236_Part3_S7-1500_Server_Panel_Client_en.pdf	This document.

3 Configuration and Project Engineering

3.1 Preparation

General

To illustrate the independence of OPC UA communication between the controller and the HMI operator panel, the application example consists of two separate sample projects.

- Project 1: STEP 7 Professional configuration.
- Project 2: WinCC Comfort configuration.

The sample projects include all the settings described in this document.

Date/time

The partners of signed and encrypted connections via OPC UA automatically exchange certificates. The certificates specify the validity period in UTC+0. The certificate recipient converts the validity period to its local time and checks it for validity. This conversion can differ depending on the device.

Make sure that all nodes in the network have the same date and time setting. In addition, make sure that the correct time zone is set and consider any automatic standard time / daylight saving time changeover.

USB flash drive

After downloading the project to the Comfort Panel and starting the runtime, the Comfort Panel generates a certificate. In a later step, this certificate must be copied to a USB flash drive and stored in the certificate manager. The certificate manager is in the STEP 7 user program configuration (see Chapter [3.2 "STEP 7 configuration \(server\)"](#), [Table 3-1](#) section "13").

Make sure that the USB flash drive is detected by the panel. Alternatively, you can use the "Sm@rtServer" service to directly access the panel's file system and directly copy the certificate.

For more information about "storage media", see [\3](#).

For more information about "network shares", see [\4](#).

STEP 7 configuration

The starting point is an existing STEP 7 Professional project with a SIMATIC S7-1500. No other components are needed in the configuration.

The application example includes a SIMATIC S7-1516 3PN/DP. Make sure that the S7-1500 uses firmware version **V2.0** or higher.

Comfort Panel

The starting point is an existing WinCC (TIA Portal) project with a SIMATIC Comfort Panel. No other components are needed in the configuration.

This application example uses a TP900 Comfort Panel.

3.2 STEP 7 configuration (server)

A STEP 7 Professional project with a CPU 1516-3PN/DP forms the basis.

OPC UA configuration

Table 3-1

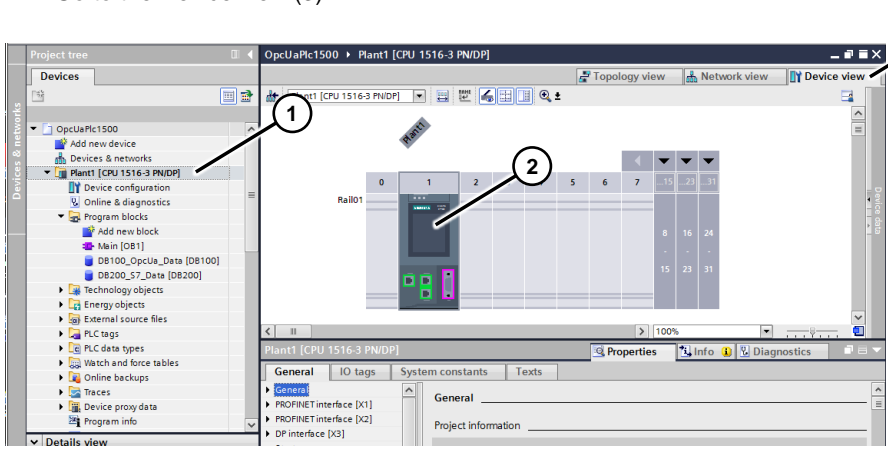
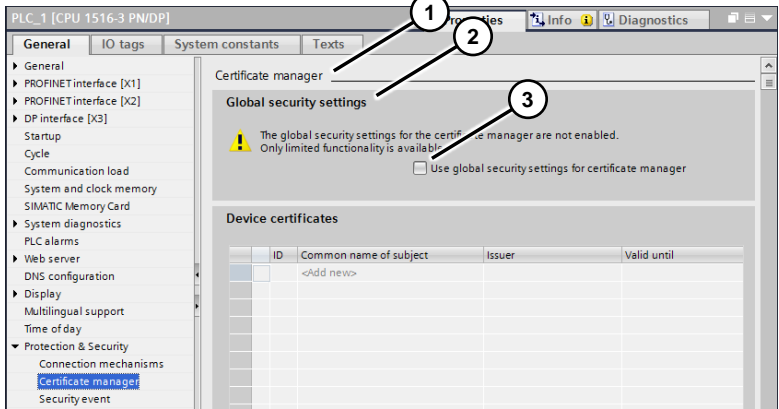
No.	Action
1.	<p>Starting the configuration console</p> <ul style="list-style-type: none"> In the project tree, open the PLC device configuration (1). Select the S7-1500 controller (2). Go to the Device view (3). 
2.	<p>Certificate manager</p> <p>In the Inspector window, open the following path. "General > Protection & Security > Certificate manager"</p> <p>"Certificate manager" section (1)</p> <ul style="list-style-type: none"> "Global security settings" (2). Check the "Use global security settings for certificate manager" check box (3). Checking the check box creates a folder named "Global security settings" in the project tree. To perform the following steps, first log in to this folder. 

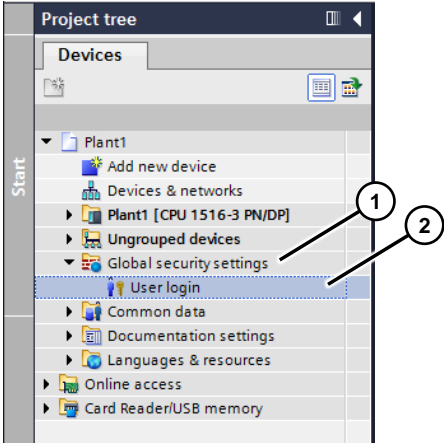
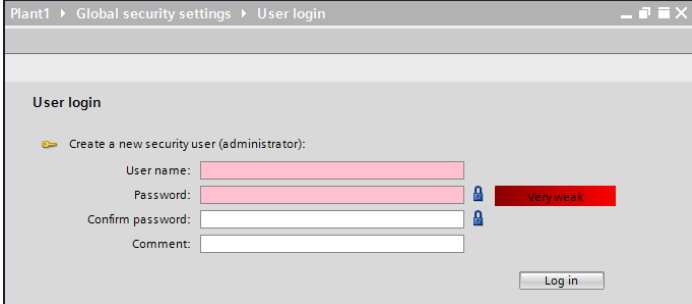
No.	Action
3.	<p>Global security settings (login)</p> <ul style="list-style-type: none"> In the project tree, navigate to the "Global security settings" folder (1). Double-click "User login". The user login window opens (2). 
4.	<p>Re-login</p> <p>When you log in for the first time, a window appears where you initially store the user data.</p> <ul style="list-style-type: none"> In this window, enter a user name and password. Use the "Log in" button to confirm your entries. <p>In this application example User: simatic Password: 100simatic</p> 

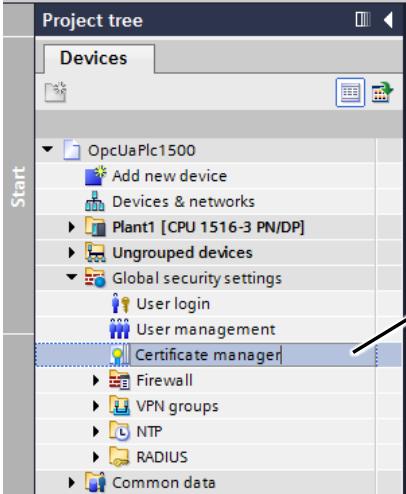
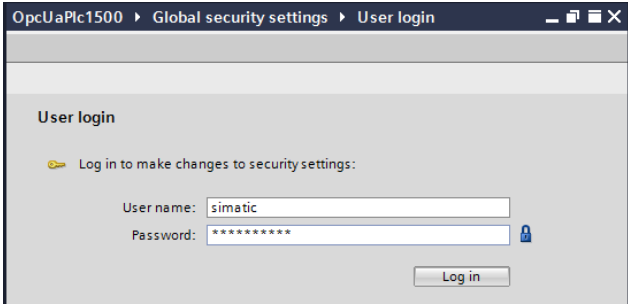
No.	Action
5.	<p>"Global security settings" view (logged in)</p> <p>The "Certificate manager" folder is displayed after successful login (1). For detailed information about the certificate manager, please refer to the information system (help).</p> 
6.	<p>To do changes under the "Global security settings"</p> <p>You need to be logged in to make changes to the "Global security settings". To log in again, click "User login" in the "Global security settings" menu in the project tree.</p> <p>Enter the user name and password and then select the "Log in" button.</p> <p>User name: simatic Password: 100simatic</p> 

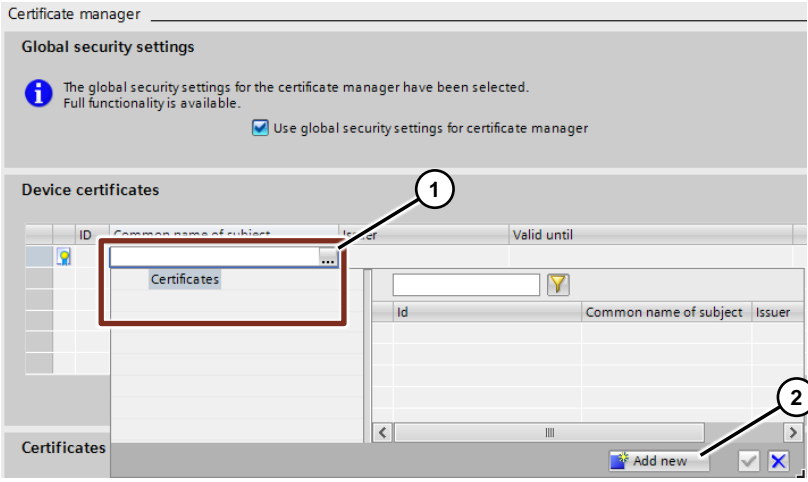
No.	Action
7.	<p>Continuing with the settings in the PLC device configuration</p> <p>Note: To perform the following steps, you need to be logged in to the "Global security settings".</p> <p>In the Inspector window, open the following path. "General > Protection & Security > Certificate manager"</p> <p>"Certificate manager" section</p> <ul style="list-style-type: none"> "Device certificates" <ul style="list-style-type: none"> In the "Common name of subject" column, click the "..." button (1) or click "<Add new>". In the new window, click the "Add" button (2). The "Create a new certificate" window opens (described in the next section).  <p>Note If the "Create a new certificate" window does not open after clicking the "..." button (1), check the "Global security settings". You need to be logged in to this folder.</p>

No.	Action
8.	<p data-bbox="518 309 965 336">- "Create a new certificate" window view</p> <div data-bbox="550 365 1166 1144" style="border: 1px solid gray; padding: 5px;"> </div> <ul style="list-style-type: none"> <li data-bbox="518 1187 981 1214">- (1) Select the "Self signed" radio button. <li data-bbox="518 1220 1300 1247">- (2) Specify any name. Choose a name that is related to the PLC/plant. <li data-bbox="518 1254 1348 1361">- (3) From the drop-down list, select the following signature. The signature must match the connection settings on the Comfort Panel. If the Comfort Panel uses the "Basic128Rsa15" setting, select "sha1RSA" from the drop-down list. <li data-bbox="518 1368 1348 1505">- (4) Specify the certificate's validity period. Note: The created certificate will later be stored on the Comfort Panel. The "time zone/UTC" set on the panel is key to ensuring that the certificate is valid immediately. <li data-bbox="550 1512 1348 1646">Tips for specifying the validity period: When specifying the validity period in "Valid from", you can edit the date and time. If the date and time in the PLC and on the Comfort Panel are identical, specify one day earlier than this date in "Valid from". Example: Current date November, 9 2016 → November, 8 2016. This makes the next steps for certificate handling easier. <li data-bbox="518 1702 1204 1729">- (5) From the drop-down list, select "OPC UA client & server". <li data-bbox="518 1736 1348 1792">- (6) Enter the server's IP address. In this case, the S7-1500 controller's IP address.

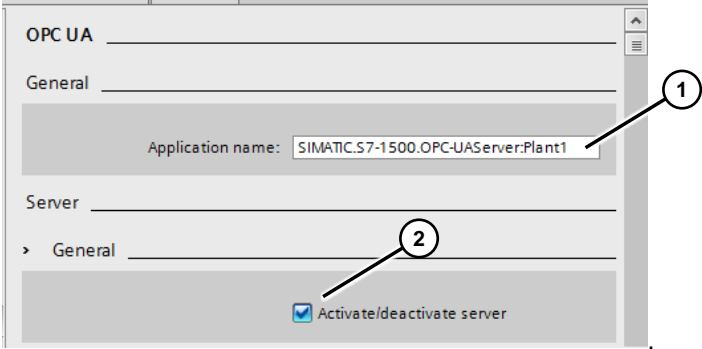
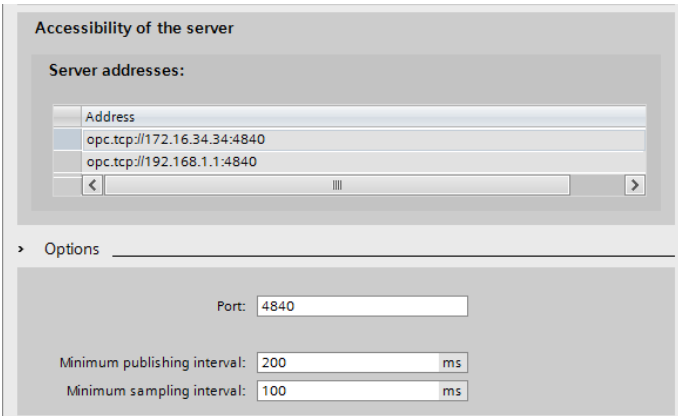
No.	Action
9.	<p>In the Inspector window, open the following path. "General > OPC UA"</p> <p>"General" section:</p> <ul style="list-style-type: none"> - Application name The name is automatically generated by the system. You can customize the name (1). The name is not relevant to the application example. <p>"Server – General" section:</p> <ul style="list-style-type: none"> - Check the "Activate/deactivate server" check box (2). A security message appears. Read and confirm the message. 
10.	<ul style="list-style-type: none"> • "Accessibility of the server" <ul style="list-style-type: none"> - Server addresses: Displays via which address the server can be accessed (in this case: the S7-1500 controller). <p>Address syntax: opc.tcp://IP-address of server:port</p> <p>"Options" section</p> <ul style="list-style-type: none"> - Port: Specifies the port address. You can specify a value between 1024 and 49151. The default address, "4840", was applied. - Publishing and sampling interval: For details, refer to the online help. (The settings are CPU-specific.) 

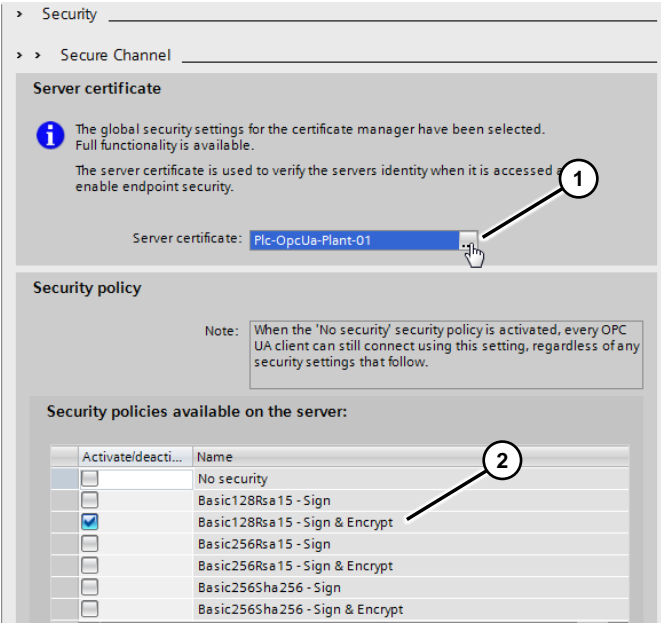
No.	Action
11.	<p>"Security > Secure Channel" section</p> <ul style="list-style-type: none"> "Server certificate" <ul style="list-style-type: none"> Server certificate: Click the "... " button (1). In the newly opened window, select the server certificate you have created. "Security policy" <ul style="list-style-type: none"> Security policy available on the server: Specify the encryption (2). Follow the settings made on the Comfort Panel in "Connections" (see Chapter 3.3.1 Creating the certificate). <p>Note Uncheck any security policies that you do not need.</p> 

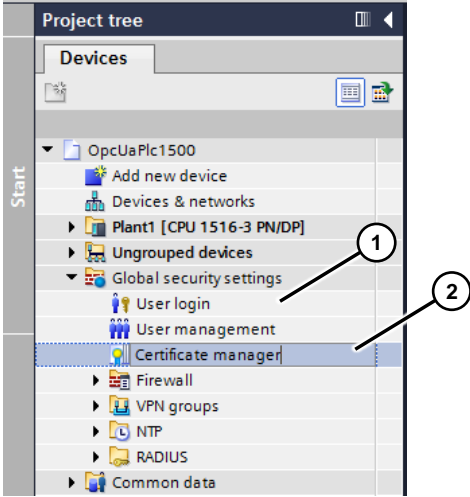
No.	Action																								
12.	<ul style="list-style-type: none"> "Trusted clients" ("General > OPC UA > Trusted clients"). - This is where you add the certificates of nodes that are allowed to connect to the controller. <div data-bbox="549 450 1329 864" style="border: 1px solid gray; padding: 5px; margin: 10px 0;"> <p>Trusted clients</p> <p> The global security settings for the certificate manager have been selected. Full functionality is available. To allow a connection to the server to be established for specific clients, their certificates can be added to the following list of trusted clients. To allow any client to establish a connection, you can enable the "Automatically accept all client certificates during runtime" option.</p> <table border="1" data-bbox="571 638 1310 779"> <thead> <tr> <th>ID</th> <th>Common name of subject</th> <th>Issuer</th> <th>Valid until</th> </tr> </thead> <tbody> <tr> <td colspan="4" style="text-align: center;"><Add new></td> </tr> <tr><td> </td><td> </td><td> </td><td> </td></tr> <tr><td> </td><td> </td><td> </td><td> </td></tr> <tr><td> </td><td> </td><td> </td><td> </td></tr> <tr><td> </td><td> </td><td> </td><td> </td></tr> </tbody> </table> <p style="text-align: right;"><input type="checkbox"/> Automatically accept all client certificates during runtime</p> </div> <p>Note: Before you perform the next steps, the certificates must have been stored in the "Global security settings > Certificate manager > Device certificates" menu.</p>	ID	Common name of subject	Issuer	Valid until	<Add new>																			
ID	Common name of subject	Issuer	Valid until																						
<Add new>																									
13.	<p>Certificate manager</p> <ul style="list-style-type: none"> Log in to the "Global security settings" (1). <p>Login data used in the application example: User name: simatic Password: 100simatic</p> <ul style="list-style-type: none"> Double-click the "Certificate manager" item to open the certificate manager (2). <div data-bbox="520 1328 992 1823" style="border: 1px solid gray; padding: 5px; margin: 10px 0;">  </div> <ul style="list-style-type: none"> In the certificate manager, select the "Device certificates" tab. 																								

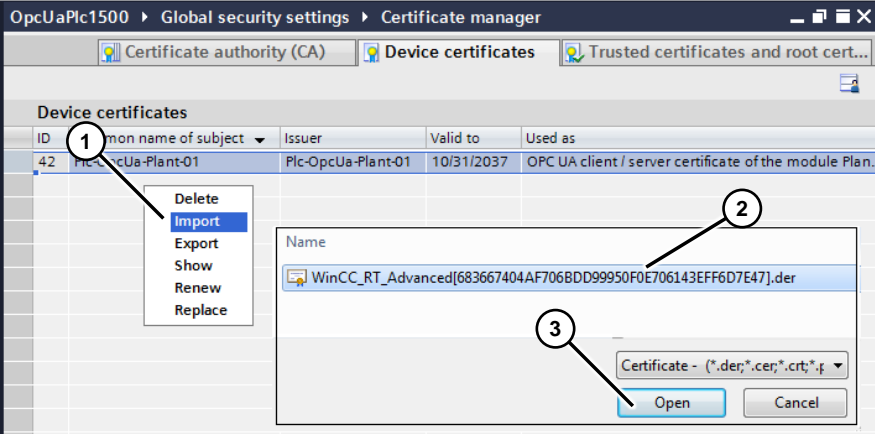
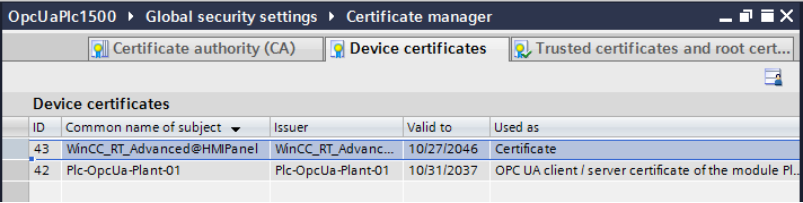
No.	Action
14.	<p>Adding the Comfort Panel certificate</p> <p>Requirement You have backed up the Comfort Panel certificate to a storage medium (see Chapter 3.3.1 Creating the certificate).</p> <ul style="list-style-type: none"> • Right-click a blank field. • From the context menu, select "Import". • Navigate to the storage location where you have stored the Comfort Panel certificate. In this case: "USB flash drive". • Select the certificate (2). • Use the "Open" button to complete the process. 
15.	<p>Newly added certificate view</p> <p>The screenshot shows the newly added Comfort Panel certificate. Memorize the ID number. In this case: "43". (If there are older certificates with the same name, the ID number allows you to determine the currently valid license more quickly.) In the PLC device configuration, you can now assign the Comfort Panel certificate to the PLC.</p> 

No.	Action																																												
16.	<p>Continuing with the settings in the PLC device configuration</p> <p>In the Inspector window, open the following path. "General > OPC UA"</p> <ul style="list-style-type: none"> "Trusted clients" ("General > OPC UA > Trusted clients"). <ul style="list-style-type: none"> - Step 1: Click "<Add new>". - Step 2: In the new window, select the certificate of the node with which the controller is to communicate. - Step 3: Use the "green check mark" to confirm your selection. - To add more nodes, repeat the above three steps. <div data-bbox="549 734 1329 1149" style="border: 1px solid gray; padding: 5px;"> <p>Trusted clients</p> <p>i The global security settings for the certificate manager have been selected. Full functionality is available. To allow a connection to the server to be established for specific clients, their certificates can be added to the following list of trusted clients. To allow any client to establish a connection, you can enable the "Automatically accept all client certificates during runtime" option.</p> <table border="1" style="width: 100%; border-collapse: collapse;"> <thead> <tr> <th>ID</th> <th>Common name of subject</th> <th>Issuer</th> <th>Valid until</th> </tr> </thead> <tbody> <tr> <td colspan="4" style="text-align: center;"><Add new></td> </tr> <tr><td> </td><td> </td><td> </td><td> </td></tr> <tr><td> </td><td> </td><td> </td><td> </td></tr> <tr><td> </td><td> </td><td> </td><td> </td></tr> <tr><td> </td><td> </td><td> </td><td> </td></tr> <tr><td> </td><td> </td><td> </td><td> </td></tr> <tr><td> </td><td> </td><td> </td><td> </td></tr> <tr><td> </td><td> </td><td> </td><td> </td></tr> <tr><td> </td><td> </td><td> </td><td> </td></tr> <tr><td> </td><td> </td><td> </td><td> </td></tr> </tbody> </table> <p style="text-align: right;"><input type="checkbox"/> Automatically accept all client certificates during runtime</p> </div> <p>Note Make sure that the "Automatically accept all client certificates during runtime" check box is unchecked (2).</p>	ID	Common name of subject	Issuer	Valid until	<Add new>																																							
ID	Common name of subject	Issuer	Valid until																																										
<Add new>																																													
17.	<p>"User authentication" section</p> <ul style="list-style-type: none"> - "Guest authentication" Select one of the options listed in this section. In this case: "Enable guest authentication" (1). <div data-bbox="549 1435 1353 1910" style="border: 1px solid gray; padding: 5px;"> <p>> > User authentication</p> <p>Guest authentication</p> <p>Note: The guest authentication allows access to the server without authentication by username/password.</p> <p><input checked="" type="checkbox"/> Enable guest authentication</p> <hr/> <p>User name and password authentication</p> <p>Note: Enabling this option allows users to authenticate themselves by providing a valid user name and password.</p> <p><input type="checkbox"/> Enable user name and password authentication</p> </div>																																												

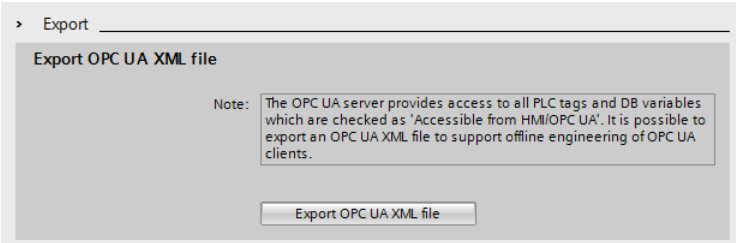
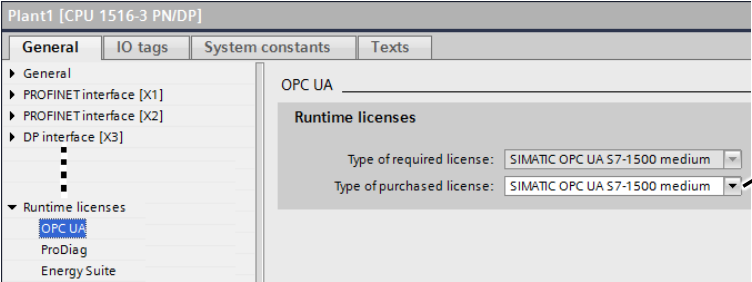
No.	Action
18.	<p>"Export" section</p> <ul style="list-style-type: none"> "Export OPC UA XML file" This function allows you to export enabled PLC and DB tags. For details about the functions, please refer to the information system (help). 
19.	<p>In the Inspector window, open the following path. "General > Runtime licenses"</p> <p>"OPC UA" section (To use the "OPC UA" option, you need a valid license)</p> <ul style="list-style-type: none"> Runtime licenses <ul style="list-style-type: none"> Type of purchased license: From the drop-down list, select the license you purchased. This case uses the "SIMATIC OPC UA S7-1500 medium" license (1).  <p>The PLC device configuration settings regarding the certificates are now complete.</p>
20.	<p>Transferring the configuration to the controller</p> <p>Transfer the configuration to the controller.</p>
21.	<p>Copying the PLC certificate</p> <p>Starting the Comfort Panel runtime transfers the PLC certificate to the "rejected" file folder of the Comfort Panel. The next step is to copy the PLC certificate.</p>
22.	<p>Continue with Chapter 3.3.2 "Assigning the PLC certificate to the Comfort Panel".</p>

3.3 Comfort Panel configuration (client)

3.3.1 Creating the certificate

A WinCC Comfort configuration with a TP900 Comfort Panel forms the basis. The interface is connected to a subnet.

Table 3-2

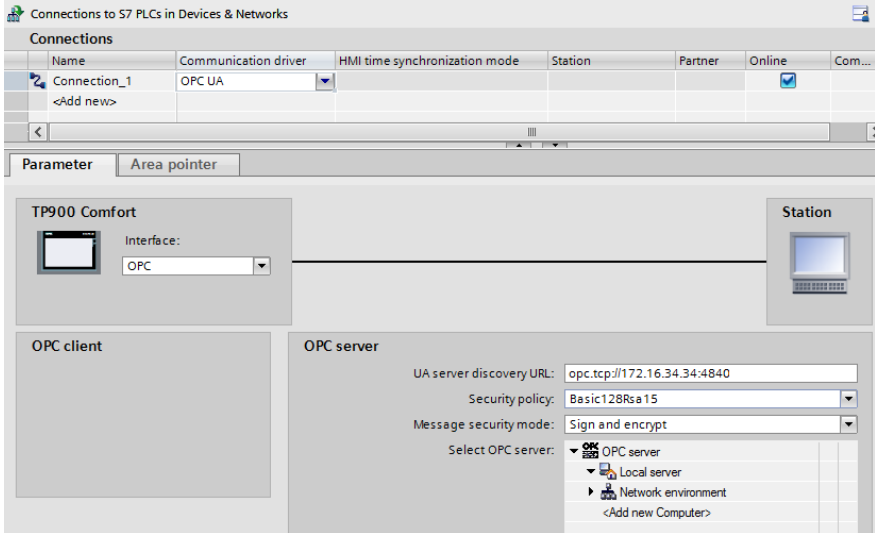
No.	Action
1.	<p>Creating the OPC UA connection</p> <ul style="list-style-type: none"> • In the project tree, open the "Connections" folder • Create a new connection • In "Communication driver", select "OPC UA" <p style="margin-left: 20px;">- "OPC server" (settings used)</p> <p style="margin-left: 20px;">UA server discovery URL: <code>opc.tcp://172.16.34.34:4840</code> Security policy: <code>Basic128Rsa15</code> Message security mode: <code>Sign and encrypt</code>.</p> 
2.	<p>Transferring the configuration</p> <p>Transfer the configuration to the Comfort Panel.</p>

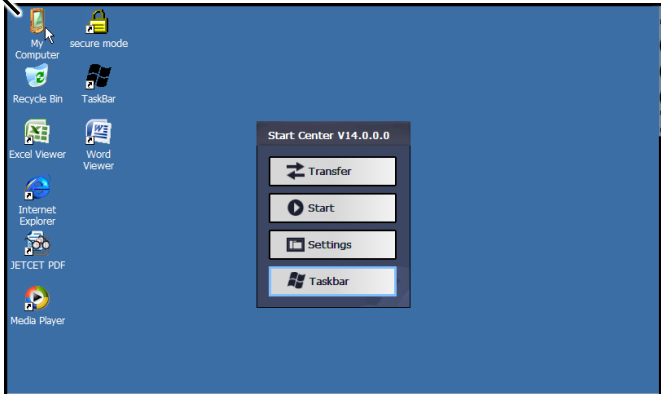
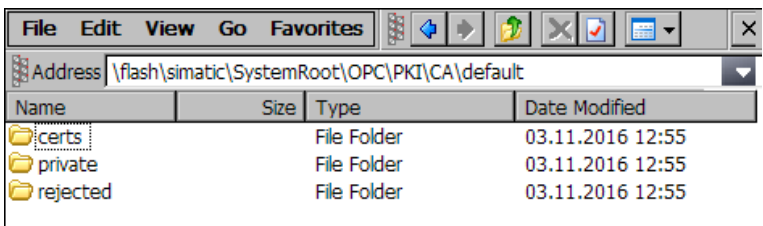
No.	Action
3.	<p>Starting runtime</p> <p>After downloading the project, start the runtime so that the certificate is created in the Comfort Panel. The certificate is stored in a system folder on the panel.</p>
4.	<p>Copying the certificate</p> <p>The certificate must be "manually" copied from the Comfort Panel and imported into the license manager. To do this, you need a USB flash drive or the "Sm@rtService" functionality (see the information provided in Chapter 3.1 – USB flash drive).</p> <p>On the panel, open Windows Explorer. To do this, click the "My Computer" icon (1).</p> 
5.	<p>Navigate to the following directory: \flash\simatic\SystemRoot\OPC\PKI\CA\default</p> <ul style="list-style-type: none"> • Open the "certs" folder. • Select the "WinCC_RT_Advanced (...)" certificate. • Copy the certificate (Edit > Copy). • Save the file, for example, to a USB flash drive (Edit > Paste). 
6.	<p>Continue configuring the PLC</p> <p>Integrate the certificate into the STEP 7 configuration (see Chapter 3.2 "STEP 7 configuration (server)", Table 3-1 section "13").</p>

...

Note

If you delete the existing certificate and restart the panel runtime, the system generates a new certificate. Please note: The new certificate has a **new** time stamp. → The certificate must be **newly** stored in the certificate manager and in the PLC device configuration!

3.3.2 Assigning the PLC certificate to the Comfort Panel

Requirements:

- You have transferred the PLC configuration to the controller.
- You have transferred the Comfort Panel configuration to the Comfort Panel.
- The Comfort Panel is connected to the PLC.

Note

If there is no connection to the PLC or the connection data does not match, no certificate will be transferred to the panel.

Table 3-3

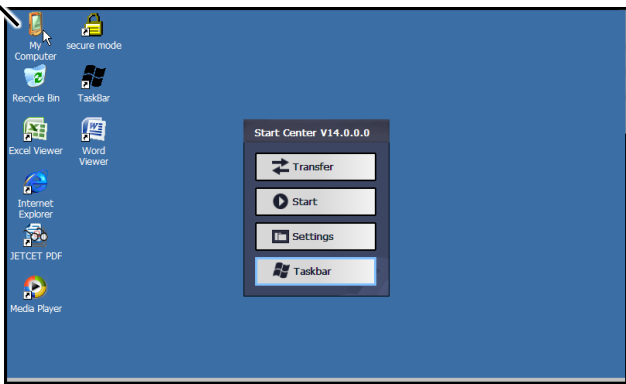
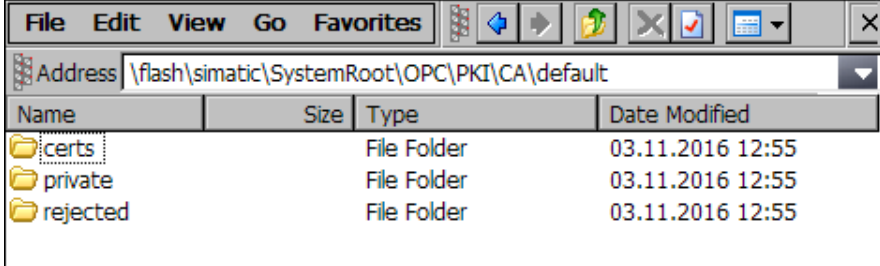
No.	Action
1.	<p>Copying the PLC certificate</p> <p>Starting the Comfort Panel runtime automatically transfers the PLC certificate to the "rejected" file folder of the Comfort Panel. Manually copy the certificate to the "certs" file folder.</p> <p>On the Comfort Panel, open Windows Explorer. To do this, click the "My Computer" icon (1).</p> 
2.	<p>Navigate to the following directory: \flash\simatic\SystemRoot\OPC\PKI\CA\default</p> 

3 Configuration and Project Engineering

3.3 Comfort Panel configuration (client)

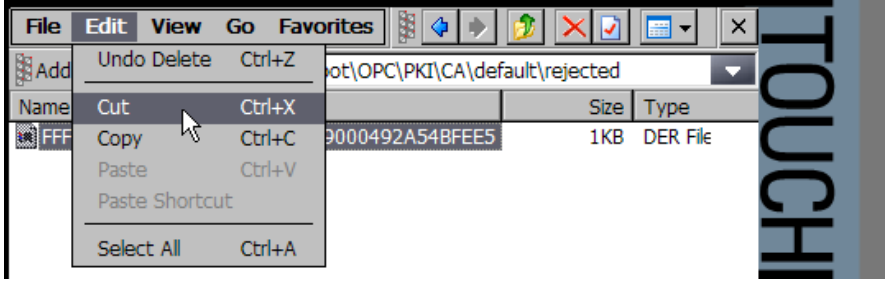
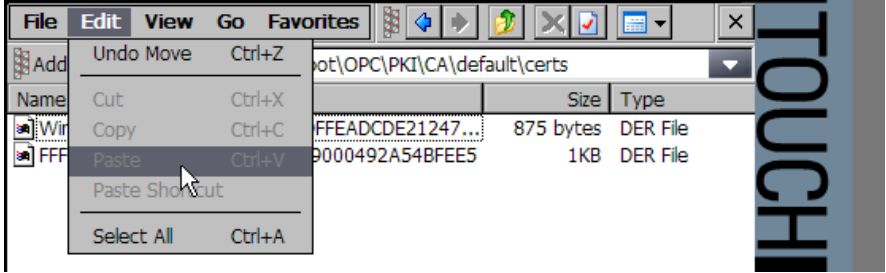
No.	Action
3.	<ul style="list-style-type: none"> • Open the "rejected" folder. • Select the "hexadecimal code ..." certificate. • Cut (do not copy) the certificate (Edit > Cut). 
4.	<ul style="list-style-type: none"> • Open the "certs" folder. • Paste the certificate into the "certs" folder. (Edit > Paste).  <p>The Comfort Panel settings are now complete.</p> <ul style="list-style-type: none"> • Close the file system. • Start the Comfort Panel runtime. <p>If the certificates have been correctly assigned, a connection is established between the Comfort Panel and the PLC.</p>

3.3.3 Online browsing to the PLC tags

From the Comfort Panel's tag editor, you can browse (online) to the PLC tags.

Table 3-4

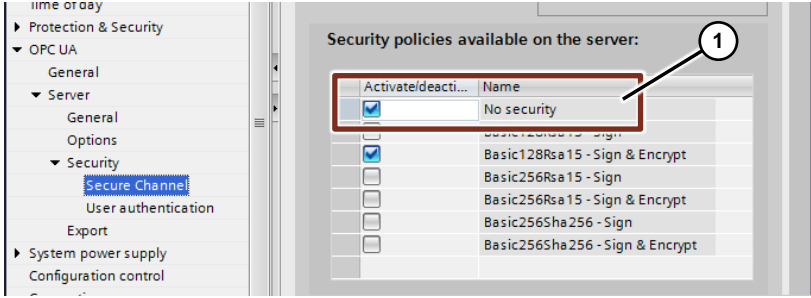
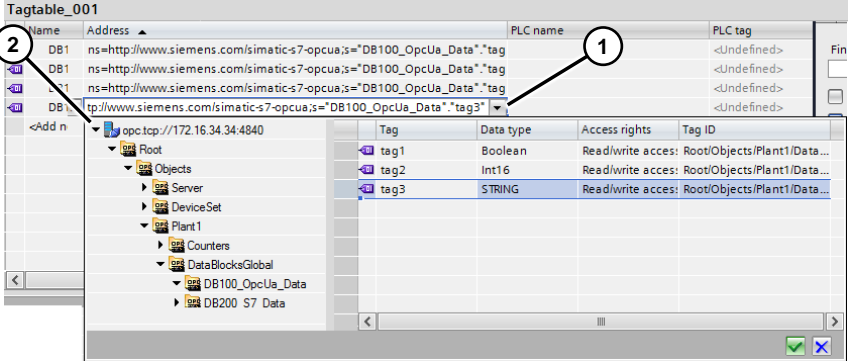
No.	Action
1.	<ul style="list-style-type: none"> Open the PLC device configuration. Open the following path "General > OPC UA > Server > Security > Secure Channel". <p>Uncheck the "security policy" for the period during which you browse "online" to the PLC tags. Check the "No security" check box (1).</p> <ul style="list-style-type: none"> Transfer the configuration to the controller. 
1.	<ul style="list-style-type: none"> Open the Comfort Panel's tag editor. In the "Address" column, open the drop-down list (1). A dialog opens (2). In the dialog, click the arrow next to the "server object". Navigate to the "Root > Objects > Plant1 > DataBlocksGlobal" folder. The folder displays the PLC tags. <p>Note The path may differ depending on the project.</p> <ul style="list-style-type: none"> Double-clicking a single tag applies the tag to the HMI project.  <p>Note: If you apply a tag of the "String" type, you must enter the "string's" "length" in the tag properties. For the "length", refer to the "original application".</p>

No.	Action
2.	To add another tag, repeat the step from table section 2.
3.	<ul style="list-style-type: none">• When you have added all required tags from the PLC, open the PLC device configuration.• Open the following path "General > OPC UA > Server > Security > Secure Channel".• Uncheck the "No security" check box.• Then transfer the configuration to the controller.

3.3.4 Device name

Make sure that the device name in the HMI configuration matches the one displayed on the Comfort Panel. The name must be correct on both sides. Customize it if necessary.

Note If the device names differ, no connection can be established using the OPC server!

3.4 Error analysis

If you cannot establish a connection between the Comfort Panel and the PLC, check the following items:

- Does the PLC certificate's validity period match the one of the certificate generated by the Comfort Panel?
Create a PLC certificate whose validity period starts one day before the validity period for the Comfort Panel certificate.
- Check the "rejected" folder of the Comfort Panel. "Cut" the PLC certificate from the "rejected" folder and paste it into the "certs" folder.
If the Comfort Panel does **not** accept the PLC certificate, the PLC certificate is automatically moved back to the "rejected" folder.
- Is the Comfort Panel certificate included in the STEP 7 OPC configuration's list of "trusted clients"?
- If you have made changes to "certificates" in the STEP 7 user program, you must transfer the user program to the controller.
- Check the version of the PLC used. SIMATIC S7-1500 V2.0 or higher supports communication with OPC UA.
- OPC Scout allows you to test the OPC connection.
- Is the certificate generated by the Comfort Panel identical to the certificate in the certificate manager? See the next section "Editing/viewing certificates".

Editing/viewing certificates

If there are multiple certificates for a device, the name does not always directly indicate which certificate is currently used. To solve this issue, you can view the certificate content.

Table 3-5

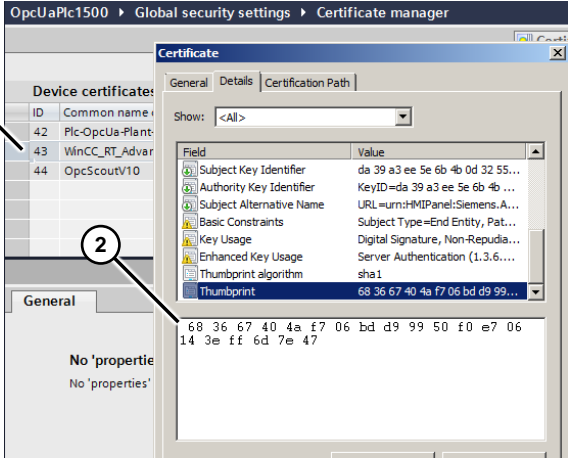
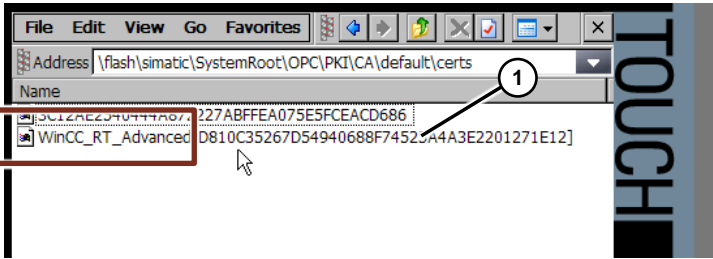
No.	Action
1.	<ul style="list-style-type: none"> In "Global security settings", open the certificate manager. Use the right mouse button to select the certificate you want to check. A context menu opens. From the context menu, select the "Show" function. In the certificate window, select the "Details" tab. Scroll to the "Thumbprint" item. It displays a unique hexadecimal number (1). Now you can compare this number, for example, to the certificate stored in the Comfort Panel. <p>Example: A "WinCC_RT_Advanced" certificate with "ID 43" (1) stored in the certificate manager and the associated "hexadecimal number" (2).</p> 
4.	<p>A "WinCC_RT_Advanced" certificate stored in the Comfort Panel.</p>  <p>In the screenshot shown in table section 1, the certificate name is the same (WinCC_RT_Advanced), but the "hexadecimal numbers" (1) differ (D8 10 C3 52 67 ...).</p> <p>(Number stored in the configuration: 68 36 37 40 4a.....):</p> <p>In this scenario, a connection would not be established between the PLC and the Comfort Panel.</p>

4 Operation of the Application Example

4.1 Startup

Table 4-1

No.	Action
1.	<p>STEP 7 user program</p> <p>Transfer the STEP 7 user program to the controller.</p>
5.	<p>WinCC Comfort configuration</p> <ul style="list-style-type: none"> Transfer the WinCC Comfort configuration to the TP900 Comfort Panel. Starting the runtime generates the Comfort Panel certificate. This certificate then needs to be integrated into the STEP 7 user program. Chapter 3.2 describes how to do this.

4.2 Operation

Overview and description of the user interface

The following sections provide a brief description of the three most important screens.

Table 4-2

No.	Action
1.	<p>Start screen</p> <p>Starting the runtime opens the following screen. On the right-hand side of the screen, a "slide-in screen" allows you to open the individual screens.</p> 

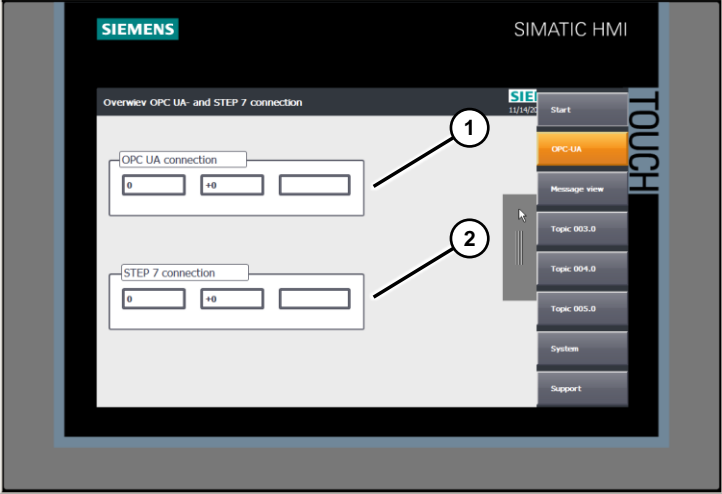
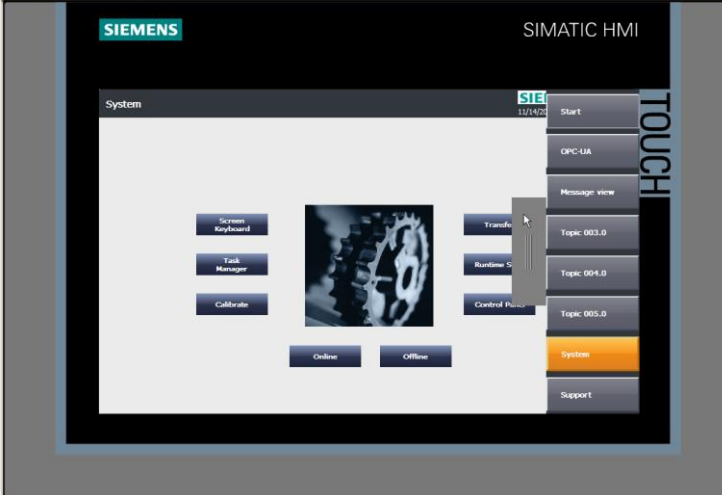
No.	Action
6.	<p>Connection overview</p> <ul style="list-style-type: none"> • Select the "Data exchange" button. The screen allows you to test communication between the Comfort Panel and the PLC. • OPC UA connection (1) Comfort Panel and PLC communicate via OPC UA connection. • STEP 7 connection (2) Comfort Panel and PLC communicate via HMI connection. <p>Note: If a connection to the PLC has been established via the "HMI connection", it must also be possible to connect to the PLC via the OPC UA connection. If this is not the case, see Chapter 3.4 "Error analysis".</p> 
7.	<p>System screen</p> <p>Select the "System" button. The screen allows you to execute the system functions shown on the screen, for example "Runtime Stop".</p> 

4 Operation of the Application Example

4.2 Operation

No.	Action
8.	Other screens The "Message view" screen is used to open the message history. The "Support" screen provides you with related online support information.

5 Links & Literature

Table 5-1

	Topic
\1\	Siemens Industry Online Support https://support.industry.siemens.com
\2\	Download page of the entry https://support.industry.siemens.com/cs/ww/en/view/63481236
\3\	Which external storage media can you use with the current SIMATIC panels and which memory card interfaces do they have? https://support.industry.siemens.com/cs/ww/en/view/21847868
\4\	Integrating HMI Operator Panels in TCP/IP Networks and access to a NAS or to a shared Windows folder https://support.industry.siemens.com/cs/ww/en/view/92346478
\5\	SIMATIC S7-1500, ET 200MP, ET 200SP, ET 200AL, ET 200pro Communication https://support.industry.siemens.com/cs/ww/en/view/59192925
\6\	

6 History

Table 6-1

Version	Date	Modifications
V1.0	04/2017	First version