

SIEMENS

SINUMERIK

SINUMERIK 840D sl / 828D Measuring cycles

Programming Manual

Preface

Description

1

Measuring variants

2

Parameter lists

3

Changes from cycle version SW4.4 and higher

A

Appendix

B

Valid for:

SINUMERIK 840D sl / 840DE sl / 828D controls

Software

CNC software, Version 4.5

SINUMERIK Operate for PCU/PC Version 4.5

02/2012

6FC5398-4BP40-3BA0

Legal information

Warning notice system

This manual contains notices you have to observe in order to ensure your personal safety, as well as to prevent damage to property. The notices referring to your personal safety are highlighted in the manual by a safety alert symbol, notices referring only to property damage have no safety alert symbol. These notices shown below are graded according to the degree of danger.

 DANGER
indicates that death or severe personal injury will result if proper precautions are not taken.

 WARNING
indicates that death or severe personal injury may result if proper precautions are not taken.

 CAUTION
with a safety alert symbol, indicates that minor personal injury can result if proper precautions are not taken.

CAUTION
without a safety alert symbol, indicates that property damage can result if proper precautions are not taken.

NOTICE
indicates that an unintended result or situation can occur if the relevant information is not taken into account.

If more than one degree of danger is present, the warning notice representing the highest degree of danger will be used. A notice warning of injury to persons with a safety alert symbol may also include a warning relating to property damage.

Qualified Personnel

The product/system described in this documentation may be operated only by **personnel qualified** for the specific task in accordance with the relevant documentation, in particular its warning notices and safety instructions. Qualified personnel are those who, based on their training and experience, are capable of identifying risks and avoiding potential hazards when working with these products/systems.

Proper use of Siemens products

Note the following:

 WARNING
Siemens products may only be used for the applications described in the catalog and in the relevant technical documentation. If products and components from other manufacturers are used, these must be recommended or approved by Siemens. Proper transport, storage, installation, assembly, commissioning, operation and maintenance are required to ensure that the products operate safely and without any problems. The permissible ambient conditions must be complied with. The information in the relevant documentation must be observed.

Trademarks

All names identified by ® are registered trademarks of Siemens AG. The remaining trademarks in this publication may be trademarks whose use by third parties for their own purposes could violate the rights of the owner.

Disclaimer of Liability

We have reviewed the contents of this publication to ensure consistency with the hardware and software described. Since variance cannot be precluded entirely, we cannot guarantee full consistency. However, the information in this publication is reviewed regularly and any necessary corrections are included in subsequent editions.

Preface

SINUMERIK documentation

The SINUMERIK documentation is organized in the following categories:

- General documentation
- User documentation
- Manufacturer/service documentation

Additional information

You can find information on the following topics at www.siemens.com/motioncontrol/docu:

- Ordering documentation/overview of documentation
- Additional links to download documents
- Using documentation online (find and search in manuals/information)

Please send any questions about the technical documentation (e.g. suggestions for improvement, corrections) to the following address:

docu.motioncontrol@siemens.com

My Documentation Manager (MDM)

Under the following link you will find information to individually compile OEM-specific machine documentation based on the Siemens content:

www.siemens.com/mdm

Training

For information about the range of training courses, refer under:

- www.siemens.com/sitrain
SITRAIN - Siemens training for products, systems and solutions in automation technology
- www.siemens.com/sinustrain
SinuTrain - training software for SINUMERIK

FAQs

You can find Frequently Asked Questions in the Service&Support pages under Product Support. <http://support.automation.siemens.com>

SINUMERIK

You can find information on SINUMERIK under the following link:

www.siemens.com/sinumerik

Target group

This programming manual is intended for machine tool programmers for the SINUMERIK Operate software.

Benefits

With the programming manual, the target group can develop, write, test, and debug programs and software user interfaces.

Standard scope

This documentation only describes the functionality of the standard version. Additions or revisions made by the machine manufacturer are documented by the machine manufacturer.

Other functions not described in this documentation might be executable in the control. This does not, however, represent an obligation to supply such functions with a new control or when servicing.

For the sake of simplicity, this documentation does not contain all detailed information about all types of the product and cannot cover every conceivable case of installation, operation, or maintenance.

Technical Support

You will find telephone numbers for other countries for technical support in the Internet under <http://www.siemens.com/automation/service&support>

Table of contents

	Preface	3
1	Description.....	9
1.1	Basics.....	9
1.2	General prerequisites.....	11
1.3	Behavior on block search, dry run, program testing, simulation.....	12
1.4	Reference points on the machine and workpiece.....	13
1.5	Definition of the planes, tool types.....	15
1.6	Probes that can be used.....	18
1.7	Probe, calibration body, calibration tool.....	22
1.7.1	Measuring workpieces on milling machines, machining centers.....	22
1.7.2	Measuring tools on milling machines, machining centers.....	23
1.7.3	Measuring workpieces at the turning machines.....	25
1.7.4	Measuring tools at lathes.....	28
1.8	Measurement principle.....	30
1.9	Measuring strategy for measuring workpieces with tool offset.....	35
1.10	Parameters for checking the measurement result and offset.....	38
1.11	Effect of empirical value, mean value, and tolerance parameters.....	43
1.12	Measuring cycle help programs.....	44
1.12.1	CYCLE116: Calculation of center point and radius of a circle.....	44
1.12.2	CUST_MEACYC: User program before/after measurements are performed.....	46
1.13	Miscellaneous functions.....	46
1.13.1	Measuring cycle support in the program editor.....	46
1.13.2	Measuring result screens.....	47
2	Measuring variants	49
2.1	General requirements.....	49
2.1.1	Overview of the measuring cycles.....	49
2.1.2	Selection of the measuring variants via softkeys (turning).....	51
2.1.3	Selection of the measuring variants via softkeys (milling).....	53
2.1.4	Result parameters.....	55
2.2	Measure workpiece (turning).....	56
2.2.1	General information.....	56
2.2.2	Calibrate probe - length (CYCLE973).....	57
2.2.3	Calibrate probe - radius on surface (CYCLE973).....	60
2.2.4	Calibrate probe - calibrate in groove (CYCLE973).....	63
2.2.5	Turning measurement - front edge (CYCLE974).....	67
2.2.6	Turning measurement - inside diameter (CYCLE974, CYCLE994).....	71
2.2.7	Turning measurement - outside diameter (CYCLE974, CYCLE994).....	76
2.2.8	Extended measurement.....	81

2.3	Measure workpiece (milling)	83
2.3.1	Calibrate probe - length (CYCLE976)	83
2.3.2	Calibrate probe - radius in ring (CYCLE976)	87
2.3.3	Calibrate probe - radius on edge (CYCLE976)	91
2.3.4	Calibrate probe - calibrate on ball (CYCLE976).....	94
2.3.5	Edge distance - set edge (CYCLE978).....	97
2.3.6	Edge distance - align edge (CYCLE998)	101
2.3.7	Edge distance - groove (CYCLE977).....	107
2.3.8	Edge distance - rib (CYCLE977).....	112
2.3.9	Corner - right-angled corner (CYCLE961)	116
2.3.10	Corner - any corner (CYCLE961)	120
2.3.11	Hole - rectangular pocket (CYCLE977)	124
2.3.12	Hole - 1 hole (CYCLE977)	128
2.3.13	Hole - inner circle segment (CYCLE979).....	132
2.3.14	Spigot - rectangular spigot (CYCLE977).....	136
2.3.15	Spigot - 1 circular spigot (CYCLE977)	140
2.3.16	Spigot - outer circle segment (CYCLE979).....	144
2.3.17	3D - align plane (CYCLE998)	148
2.3.18	3D - sphere (CYCLE997).....	152
2.3.19	3D - 3 spheres (CYCLE997)	156
2.3.20	3D - angular deviation spindle (CYCLE995).....	161
2.3.21	3D - kinematics (CYCLE996).....	165
2.4	Measure tool (turning)	181
2.4.1	General information.....	181
2.4.2	Calibrate probe (CYCLE982)	184
2.4.3	Turning tool (CYCLE982).....	188
2.4.4	Milling tool (CYCLE982).....	192
2.4.5	Drill (CYCLE982).....	199
2.4.6	Measure tool with toolholder that can be orientated	204
2.5	Measure tool (milling).....	206
2.5.1	General information.....	206
2.5.2	Calibrate probe (CYCLE971)	208
2.5.3	Measure tool (CYCLE971).....	214
3	Parameter lists.....	223
3.1	Overview of measuring cycle parameters.....	223
3.1.1	CYCLE973 measuring cycle parameters.....	223
3.1.2	CYCLE974 measuring cycle parameters.....	226
3.1.3	CYCLE994 measuring cycle parameters.....	229
3.1.4	CYCLE976 measuring cycle parameters.....	232
3.1.5	CYCLE978 measuring cycle parameters.....	234
3.1.6	CYCLE998 measuring cycle parameters.....	237
3.1.7	CYCLE977 measuring cycle parameters.....	240
3.1.8	CYCLE961 measuring cycle parameters.....	243
3.1.9	CYCLE979 measuring cycle parameters.....	246
3.1.10	CYCLE997 measuring cycle parameters.....	249
3.1.11	CYCLE995 measuring cycle parameters.....	252
3.1.12	CYCLE996 measuring cycle parameters.....	254
3.1.13	CYCLE982 measuring cycle parameters.....	257
3.1.14	CYCLE971 measuring cycle parameters.....	260
3.2	Additional parameters	263

3.3	Additional result parameters	265
3.4	Parameter	266
A	Changes from cycle version SW4.4 and higher	267
A.1	Assignment of the measuring cycle parameters to MEA_FUNCTION_MASK parameters	267
A.2	Changes in the machine and setting data from SW 4.4	270
A.3	Complete overview of the changed cycle machine and cycle setting data	271
A.4	Comparing GUD parameters (regarding measuring functions)	273
A.5	Changes to names of cycle programs and GUD modules	276
B	Appendix.....	277
B.1	Abbreviations	277
B.2	Documentation overview.....	278
	Glossary	279
	Index.....	285

Description

1.1 Basics

General information

Measuring cycles are general subroutines designed to solve specific measurement tasks. They can be adapted to specific problems via parameter settings.

When taking general measurements, a distinction is made between

- Tool measurement and
- Workpiece measurement.

Workpiece measurement

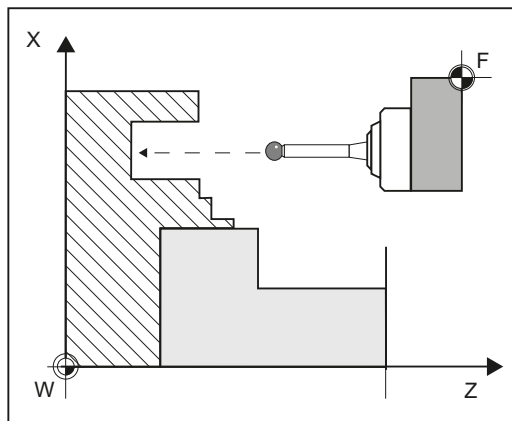

Workpiece measurement, turning example

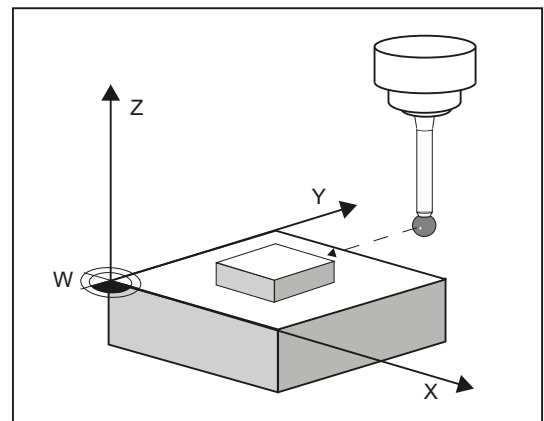

Workpiece measurement, milling example

In workpiece measurement, a probe is moved up to the clamped workpiece in the same way as a tool and the measured values are acquired. The flexibility of measuring cycles makes it possible to perform nearly all measurements required on a milling or turning machine.

The result of the workpiece measurement can be optionally used as follows:

- Compensation in the work offset
- Automatic tool offset
- Measurement without offset

Tool measurement

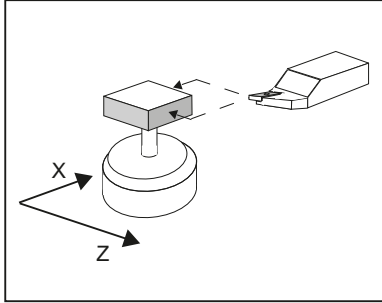

Tool measurement, turning tool example

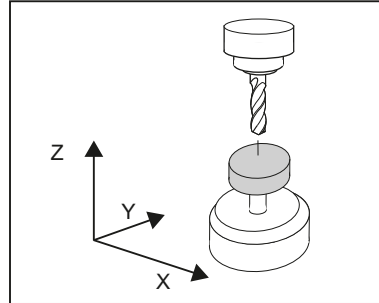

Tool measurement, drill example

In tool measurement, the selected tool is moved up to the probe and the measured values are acquired. The probe is either in a fixed position or is swung into the working area with a mechanism. The tool geometry measured is entered in the appropriate tool offset data set.

1.2 General prerequisites

Certain preconditions must be met before measuring cycles can be used. These are described in detail in the *SINUMERIK 840D sl Base Software and Operating Software*.

Check the preconditions using the following checklist:

- **Machine**

- All machine axes are designed in accordance with DIN 66217.
- Machine data has been adapted.

- **Starting position**

- The reference points have been approached.
- The starting position can be reached by linear interpolation without collision.

- **Display functions of the measuring cycles**

A HMI/PCU or HMI/TCU is required for showing the measuring result displays and for measuring cycle support.

- **Please observe the following when programming:**

- Tool radius compensation is deselected before it is called (G40).
- The cycle is called no later than at the 5th program level.
- The measurement is also possible in a system of units that differs from the basic system (with technology data that has been switched over).

For **metric** dimension system with active G70, G700.

For **inch** dimension system with active G71, G710.

References

Supplementary information for this documentation is provided in the following manuals:

- Commissioning Manual *SINUMERIK 840D sl Base Software and Operating Software*
 - /IM9/ SINUMERIK Operate
- /PG/, Programming Manual *SINUMERIK 840D sl / 828D Fundamentals*
- /FB1/, Function Manual *Basic Functions*
- /FB2/, Function Manual *Expanded Functions*
- /FB3/, Function Manual *Special Functions*

1.3 Behavior on block search, dry run, program testing, simulation

Function

The measuring cycles are skipped during execution if one of the following execution modes is active:

- "Trial run" (\$P_DRYRUN=1)
- "Program test" (\$P_ISTEST=1)
- "Block search" (\$P_SEARCH=1), only if \$A_PROTO=0.

Simulation

The simulation of the measuring cycles is realized in the user interface (HMI) in the "Program Editor" area.

Following settings are possible in the channel-specific setting data SD 55618:

- SD 55618 \$SCS_MEA_SIM_ENABLE = 0
The measuring cycle is skipped, the HMI simulation shows no path motion of the probe.
- SD 55618 \$SCS_MEA_SIM_ENABLE = 1
The measuring cycle is executed, the HMI simulation shows the corresponding path motion of the probe.
No measurements, tool or work offsets are made.
Activated functions such as "measuring result display" or "travel with collision monitoring" are not implemented.

1.4 Reference points on the machine and workpiece

General information

Depending on the measuring task, measured values may be required in the machine coordinate system (MCS) or in the workpiece coordinate system (WCS).

For example: It may be easier to ascertain the tool length in the machine coordinate system.

Workpiece dimensions are measured in the workpiece coordinate system.

Where:

- M = machine zero in the machine coordinate system
- W = workpiece zero in the workpiece coordinate system
- F = Tool reference point

Reference points

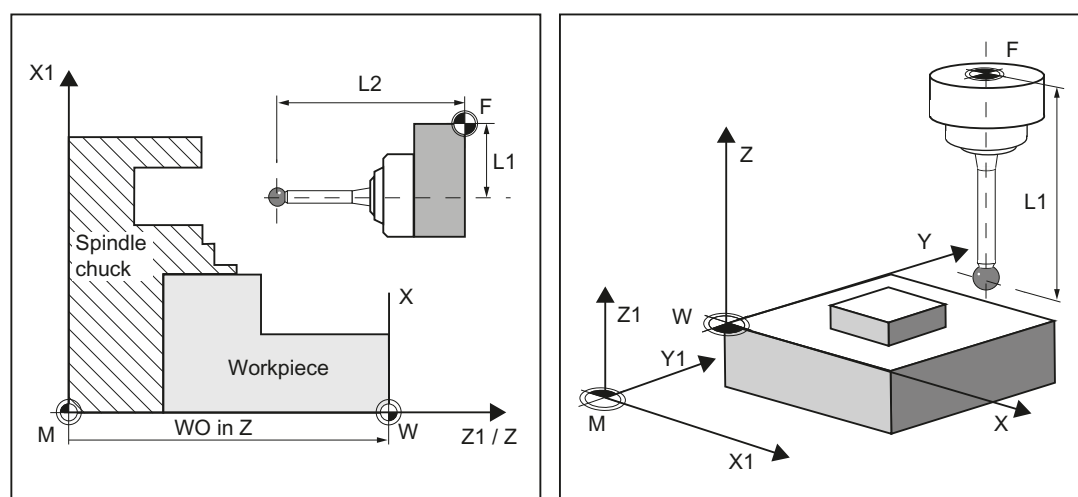

The position of tool reference point F in the machine coordinate system is defined with machine zero M as the **machine actual value**.

The position of the tip/cutting edge of the active tool in the workpiece coordinate system is displayed with the workpiece zero W as **workpiece actual value**. For a workpiece probe, the center or the end of the probe ball can be defined as the tool tip.

The **work offset (WO)** characterizes the position of the workpiece zero W in the machine coordinate system.

Work offsets (WO) comprise the components offset, rotation, mirroring and scaling factor (only the global basis work offset does not contain any rotation).

1.4 Reference points on the machine and workpiece

A distinction is made between the basis, work offset (G54 ... G599) and programmable work offset. The basic area contains further subsections – such as the basic work offset, channel-specific basic work offset and configuration-dependent work offsets (e.g. rotary table reference or basic reference).

The specified work offsets are effective together as chain and result in the workpiece coordinate system.

Note

Scale factors with a scaling value unequal to "1" are not supported by the measuring cycles! Mirroring functions are only permitted in conjunction with counterspindles on lathes.

The machine and workpiece coordinate system can be set and programmed separately in the "inch" or "metric" system of units (G70/G71).

Note

Transformation

- Measure workpiece

Workpiece measurements are always performed in the workpiece coordinate system. All descriptions relating to workpiece measurement refer to it!

- Measure tool

When measuring tools with kinematic transformation active, a distinction is made between **basic coordinate system** and **machine coordinate system**.

If kinematic transformation is deactivated, this distinction is made.

All subsequent descriptions relating to tool measurement assume that kinematic transformation is disabled and therefore refer to the machine coordinate system.

1.5 Definition of the planes, tool types

When measuring under milling, machining planes G17, G18 or G19 can be selected.

When measuring under turning, machining plane G18 must be selected.

For tool measurement, the following tool types are permitted:

- Milling, type 1..
- Drill, type 2 ...
- Turning tools, type 5 ...

Depending on the tool type, the tool lengths are assigned to the axes as follows:

- Workpiece probe, milling: Probe types 710, 712, 713, 714
- Workpiece probe, turning: Probe type, 580

Milling

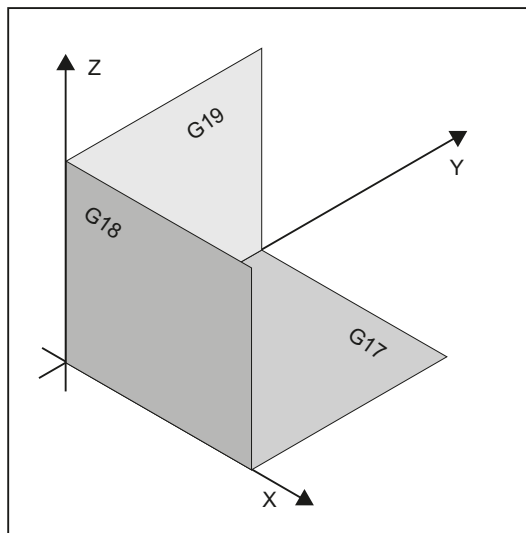

	Acts in ...	G17 plane	G18 plane	G19 plane
	Tool type:	1xy / 2xy / 710		
Length 1	1. Axis of the plane:	Z	Y	X
Length 2	2. Axis of the plane:	Y	X	Z
Length 3	3. Axis of the plane:	X	Z	Y

Lengths 2 and 3 are used in special cases, for example, if an angle head is attached.

Example of plane definition for milling

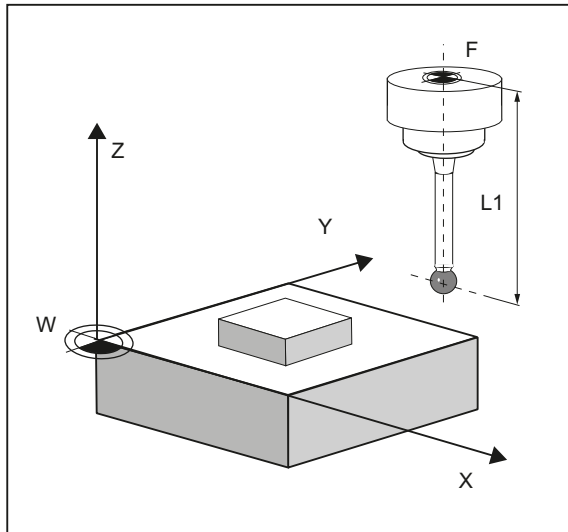
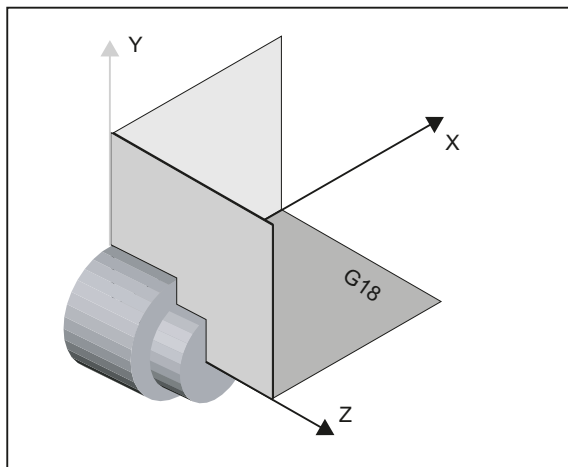

Figure 1-1 Example: Milling machine with G17

Turning



Turning machines generally only use axes Z and X and therefore:

G18 plane

Tool type	5xy (turning tool, workpiece probe)
Length 1	Acts in X (2nd axis of the plane)
Length 2	Acts in Z (1st axis of the plane)

G17 and G19 are used for milling on a turning machine. If there is no machine axis Y, milling can be implemented with the following kinematic transformations.

- TRANSMIT
- TRACYL

In principle, measuring cycles support kinematic transformations. This is stated more clearly in the individual cycles, measuring variants. Information about kinematic transformation can be found in the Programming Manual *SINUMERIK 840D sl / 828D Fundamentals* or in the documentation of the machine manufacturer.

Note

If a drill or milling cutter is measured on a lathe, in most cases, the channel-specific SD 42950 \$SC_TOOL_LENGTH_TYPE = 2 is set: These tools are then length-compensated like a turning tool.

SINUMERIK controls have other machine and setting data that can influence calculation of a tool.

References:

- /FB1/, Function Manual *Basic Functions*
- /FB2/, Function Manual *Expanded Functions*
- /FB3/, Function Manual *Special Functions*

Example of plane definition for turning

Figure 1-2 Example: Lathe with G18

1.6 Probes that can be used

General information

To measure tool and workpiece dimensions, an electronic touch-trigger probe is required that provides a signal change (edge) when deflected with the required repeat accuracy.

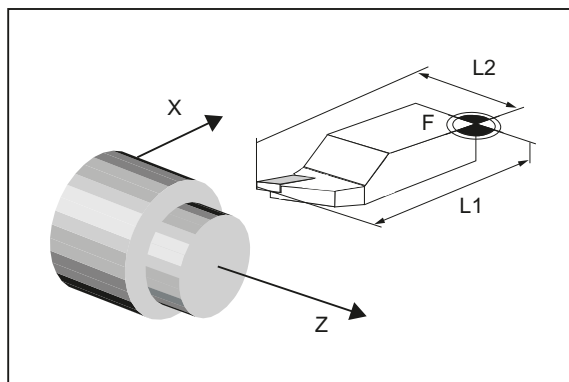
The probe must operate virtually bounce-free.

Different types of probe are offered by different manufacturers.

Note

Please observe the information provided by the manufacturers of electronic probes and/or the machine manufacturer's instructions on the following points:

- Electrical connection
- Mechanical calibration of the probe
- If a workpiece probe is used, both the direction of deflection and transmission of switching signal to the machine column (radio, infrared light or cable) must be taken into account. In some versions, transmission is only possible in particular spindle positions or in particular ranges. This can restrict the use of the probe.

Probes are distinguished according to the number of measuring directions.

- Multi-directional (multi probe)
- Mono directional (mono probe)

Workpiece probe		Tool probe	
Multi-directional (3D)	Monodirectional	Milling machines	Lathes

The probes also differ in the form of the stylus tip: the measuring cycles support pin, L and star probes as autonomous tool types. The use of the probe types is referenced in the individual measuring cycles. The multi probe is universally applicable.

The use of probes requires a spindle that can be positioned. For a mono probe, the switching direction is tracked for each measurement by turning the spindle. This can lead to a longer program runtime.

Workpiece probe types

The following probe types are provided in the tool management for measuring with workpiece probes:





710	- 3D probe	
712	- Mono probe	
713	- L probe	
714	- Star probe	
725	- Calibrating tool	

Figure 1-3 Probe types in the tool management

There is a calibration tool to calibrate tool probes (type 725) = cylindrical pin

Tool data from probes

The probes differ as a result of the tool type and the switching directions in tool parameter \$TC_DP25[] bit16 to bit 25. The switching directions are permanently coded when creating the tool.

In the application, the probe can encompass several of the following tool types. In this case, several cutting edges should be created for the probe (D1, D2, etc.).

Example: Multi probe with a boom

D1 3D_PROBE Type 710
D2 L_PROBE Type 713

The user must take into account the geometry of the probe when pre-positioning. To do this, you can read out individual tool data in the user program:

Example:

```
IF (($P_TOOLNO>0) AND ($P_TOOL>0))
  R1= ($P_AD[6]                    ;Read tool radius of the actual tool
ENDIF
```

The probe is aligned in the + X direction using parameter **offset angle** .

Description

1.6 Probes that can be used

3D_PROBE (multi probe)

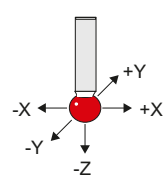
Representation	Properties	Feature
	Application:	Universal
	Type:	\$TC_DP1[]=710
	Tool length:	in Z (for G17)
	Offset angle:	\$TC_DP10[] = 0
	Switching directions:	\$TC_DP25[] = hex 0x00000000

MONO PROBE

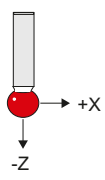
Representation	Properties	Feature
	Application:	Alignment of the switching direction when measuring
	Type:	\$TC_DP1[]=712
	Tool length:	in Z (for G17)
	Offset angle:	\$TC_DP10[] = 0 to 359.9 degrees
	Switching directions:	\$TC_DP25[] = hex 0x00120000

L_PROBE

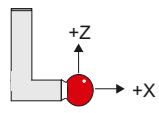
Representation	Properties	Feature
	Application:	Towing measurement in +Z
	Type:	\$TC_DP1[]=713
	Tool length:	in Z (for G17)
	Offset angle:	\$TC_DP10[] = 0 to 359.9 degrees
	Switching directions:	\$TC_DP25[] = hex 0x00220000
	Radius in the plane (length of the boom):	\$TC_DP6[]
	Radius of the probe ball in the tool direction:	\$TC_DP7[]

The tool length is the reference point of the tool holder with the equator of the probe ball.

STAR PROBE

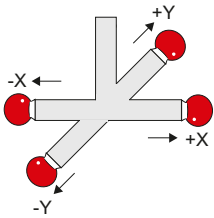
Representation	Properties	Feature
	Application:	Measure hole parallel to the axis ¹⁾
	Type:	\$TC_DP1[]=714
	Tool length:	in Z (for G17)
	Offset angle:	\$TC_DP10[] = 0 to 359.9 degrees
	Switching directions:	\$TC_DP25[] = hex 0x000F0000
	Radius in the plane (diameter of the star parallel to the axis):	\$TC_DP6[]
	Radius of the probe ball in the tool direction:	\$TC_DP7[]

- ¹⁾ The applications only refer to measurements in the plane (for G17 XY). Measurement in the tool direction is not permitted using a star probe. If a measurement is to be made in the tool direction, a star element (boom) must be declared as an L probe.

The tool length is the reference point of the tool holder with the equator of one of the probe balls.

Assignment of the probe types

Probe type	Lathes		Milling and machining centers
	Tool measurement	Workpiece measurement	Workpiece measurement
Multidirectional	X	X	X
Monodirectional	--	--	X

1.7 Probe, calibration body, calibration tool

1.7.1 Measuring workpieces on milling machines, machining centers

Probe calibration

All probes must be mechanically correctly adjusted before use. The switching directions must be calibrated before they are used in the measuring cycles for first-time. This also applies when changing the stylus tip of the probe.

When being calibrated, the trigger points (switching points), position deviation (skew), and active ball radius of the workpiece probe are determined and entered into the data fields of the general setting data SD 54600 \$SNS_MEA_WP_BALL_DIAM . There are 12 data fields.

Calibration can be realized in a calibration ring (known bore), on a calibration ball or on workpiece surfaces, which have an appropriate geometrical precision and low surface roughness.

Use the same measuring velocity for calibrating and measuring. This applies in particular to the feedrate override.

Measuring cycle CYCLE976 with different measuring versions is available to calibrate the probe.

See also

Calibrate probe - length (CYCLE976) (Page 83)

Calibrate probe - radius in ring (CYCLE976) (Page 87)

Calibrate probe - radius on edge (CYCLE976) (Page 91)

Calibrate probe - calibrate on ball (CYCLE976) (Page 94)

1.7.2 Measuring tools on milling machines, machining centers

Tool probe

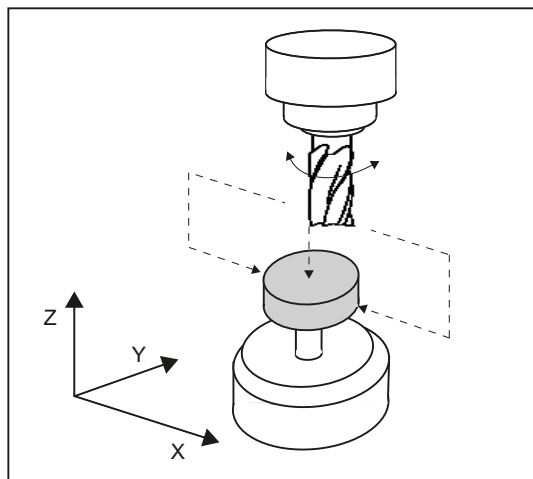

Figure 1-4 Measuring a milling cutter

Tool probes have their own data fields in the general setting data:

- For machine-related measurement/calibration:
 - SD 54625 \$SNS_MEA_TP_TRIG_MINUS_DIR_AX1
 - SD 54626 \$SNS_MEA_TP_TRIG_PLUS_DIR_AX1
 - SD 54627 \$SNS_MEA_TP_TRIG_MINUS_DIR_AX2
 - SD 54628 \$SNS_MEA_TP_TRIG_PLUS_DIR_AX2
- For workpiece-related measurement/calibration:
 - SD 54640 \$SNS_MEA_TPW_TRIG_MINUS_DIR_AX1
 - SD 54641 \$SNS_MEA_TPW_TRIG_PLUS_DIR_AX1
 - SD 54642 \$SNS_MEA_TPW_TRIG_MINUS_DIR_AX2
 - SD 54643 \$SNS_MEA_TPW_TRIG_PLUS_DIR_AX2

The triggering points (switching points), upper disk diameter and edge length are entered here.

Approximate values must be entered here before calibration – if cycles are used in automatic mode. The cycle will then recognize the position of the probe.

The default setting has data fields for three probes. Up to 99 are possible.

Calibration, calibration tool

A probe must be calibrated before it can be used. Calibration involves precisely determining the triggering points (switching points) of the tool probe and entering them in special data fields.

Calibration is performed with a calibration tool. The precise dimensions of the tool are known.

Use the same measuring velocity for calibrating and measuring.

Measurement version Calibrate probe (CYCLE971) (Page 208) is ready for calibration.

Entry in tool memory		Calibrating tool probes
Tool type (\$TC_DP1[]):	1xy	
Length 1 - geometry (\$TC_DP3[]):	L1	
Radius (\$TC_DP6[]):	r	
Length 1 - basic dimension (\$TC_DP21[]):	only if required	

The wear and other tool parameters must be assigned the value 0.

1.7.3 Measuring workpieces at the turning machines

Workpiece probe

On turning machines, the workpiece probes are treated as tool type 5xy with permissible cutting edge positions (SL) 5 to 8 and must be entered in the tool memory accordingly.

Lengths specified for turning tools always refer to the tool tip, except in the case of workpiece probes on turning machines where they refer to the probe center.

Probes are classified according to their position:

Workpiece probe SL 7

Entry in tool memory		Workpiece probe for a lathe
Tool type (\$TC_DP1[]):	5xy	
Cutting edge (\$TC_DP2[]):	7	
Length 1 - geometry:	L1	
Length 2 - geometry:	L2	
Radius (\$TC_DP6[]):	r	
Length 1 - basic dimension (\$TC_DP21[]):	only if required	
Length 2 - basic dimension (\$TC_DP22[]):	only if required	

The wear and other tool parameters must be assigned the value 0.

Workpiece probe SL 8

Entry in tool memory		Workpiece probe for a lathe
Tool type (\$TC_DP1[]):	5xy	
Cutting edge (\$TC_DP2[]):	8	
Length 1 - geometry:	L1	
Length 2 - geometry:	L2	
Radius (\$TC_DP6[]):	r	
Length 1 - basic dimension (\$TC_DP21[]):	only if required	
Length 2 - basic dimension (\$TC_DP22[]):	only if required	

The wear and other tool parameters must be assigned the value 0.

Description

1.7 Probe, calibration body, calibration tool

Workpiece probe SL 5 or SL 6

Entry in tool memory		Workpiece probe for a lathe
Tool type (\$TC_DP1[]):	5xy	
Cutting edge (\$TC_DP2[]):	5 or 6	
Length 1 - geometry:	L1	
Length 2 - geometry:	L2	
Radius (\$TC_DP6[]):	r	
Length 1 - basic dimension (\$TC_DP21[]):	only if required	
Length 2 - basic dimension (\$TC_DP22[]):	only if required	

The wear and other tool parameters must be assigned the value 0.

Calibration, gauging block

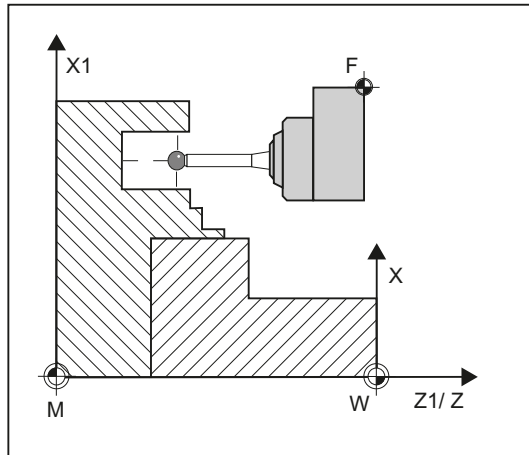

Figure 1-5 Calibrating a workpiece probe, example: Calibrating in the reference groove

A probe must be calibrated before it can be used. When being calibrated, the trigger points (switching points), position deviation (skew), and precise ball radius of the workpiece probe are determined and entered into the corresponding data fields of the general setting data SD 54600 \$SNS_MEA_WP_BALL_DIAM .

The default setting has data fields for 12 probes.

Calibration of the workpiece probe on turning machines is usually performed with gauging blocks (reference grooves). The precise dimensions of the reference groove are known and entered in the associated data fields of the following general setting data:

- SD54615 \$SNS_MEA_CAL_EDGE_BASE_AX1
- SD54616 \$SNS_MEA_CAL_EDGE_UPPER_AX1
- SD54617 \$SNS_MEA_CAL_EDGE_PLUS_DIR_AX1
- SD54618 \$SNS_MEA_CAL_EDGE_MINUS_DIR_AX1
- SD54619 \$SNS_MEA_CAL_EDGE_BASE_AX2
- SD54620 \$SNS_MEA_CAL_EDGE_UPPER_AX2
- SD54621 \$SNS_MEA_CAL_EDGE_PLUS_DIR_AX2
- SD54622 \$SNS_MEA_CAL_EDGE_MINUS_DIR_AX2

The default setting has data fields for three gauging blocks. In the measuring cycle program, the selection is made using the number of the gauging block (S_CALNUM).

It is also possible to calibrate on a known surface.

Measuring cycle CYCLE973 with various measuring versions is ready for calibration.

See also

Calibrate probe - length (CYCLE973) (Page 57)

Calibrate probe - radius on surface (CYCLE973) (Page 60)

Calibrate probe - calibrate in groove (CYCLE973) (Page 63)

1.7.4 Measuring tools at lathes

Tool probe

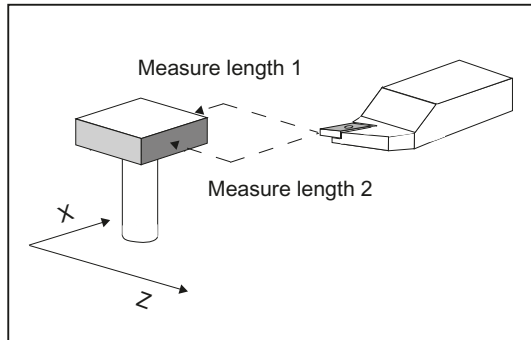

Figure 1-6 Measuring a turning tool

Tool probes have their own data fields in the general setting data:

- For machine-related measurement/calibration:
 - SD 54626 \$SNS_MEA_TP_TRIG_PLUS_DIR_AX1
 - SD 54625 \$SNS_MEA_TP_TRIG_MINUS_DIR_AX1
 - SD 54627 \$SNS_MEA_TP_TRIG_MINUS_DIR_AX2
 - SD 54628 \$SNS_MEA_TP_TRIG_PLUS_DIR_AX2
- For workpiece-related measurement/calibration:
 - SD 54641 \$SNS_MEA_TPW_TRIG_PLUS_DIR_AX1
 - SD 54640 \$SNS_MEA_TPW_TRIG_MINUS_DIR_AX1
 - SD 54642 \$SNS_MEA_TPW_TRIG_MINUS_DIR_AX2
 - SD 54643 \$SNS_MEA_TPW_TRIG_PLUS_DIR_AX2

The triggering points (switching points) are entered here. Approximate values must be entered here before calibration – if cycles are used in automatic mode. The cycle will then recognize the position of the probe.

The default setting has data fields for 6 probes.

In addition to turning tools, drills and mills can also be measured.

Calibration, gauging block

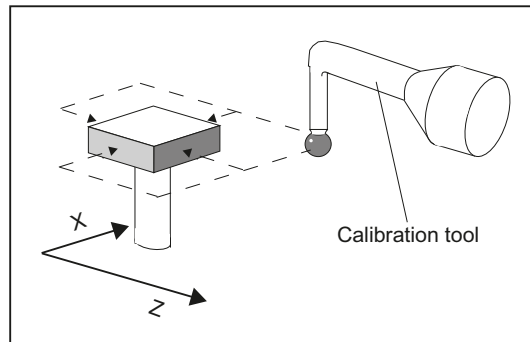

A probe must be calibrated before it can be used. Calibration involves precisely determining the triggering points (switching points) of the tool probe and entering them in special data fields.

Calibration is performed with a calibration tool. The precise dimensions of the tool are known.

Measurement version Calibrate probe (CYCLE982) (Page 184) is ready for calibration.

For lathes, the calibration tool is treated like a turning tool with cutting edge position 3. The lengths refer to the ball circumference, not to the ball center.

Entry in tool memory		Calibration tool for a tool probe on a lathe
Tool type (\$TC_DP1[]):	5xy	
Cutting edge (\$TC_DP2[]):	3	
Length 1 - geometry:	L1	
Length 2 - geometry:	L2	
Radius (\$TC_DP6[]):	r	
Length 1 - basic dimension (\$TC_DP21[]):	only if required	
Length 2 - basic dimension (\$TC_DP22[]):	only if required	

The wear and other tool parameters must be assigned the value 0.

1.8 Measurement principle

Flying measurement

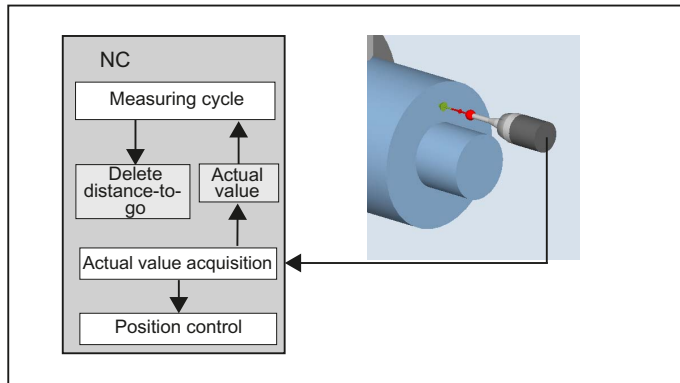

The principle of "flying measurement" is implemented in the SINUMERIK control. The probe signal is processed directly on the NC so that the delay when acquiring measured values is minimal. This permits a higher measuring speed for the prescribed measuring precision and time needed for measuring is reduced.

Connecting probes

Two inputs for connecting touch trigger probes are provided on the I/O device interface of the SINUMERIK control systems.



Machine manufacturer

Please observe the machine manufacturer's instructions.

Measurement operation sequence using the example set edge (CYCLE978)

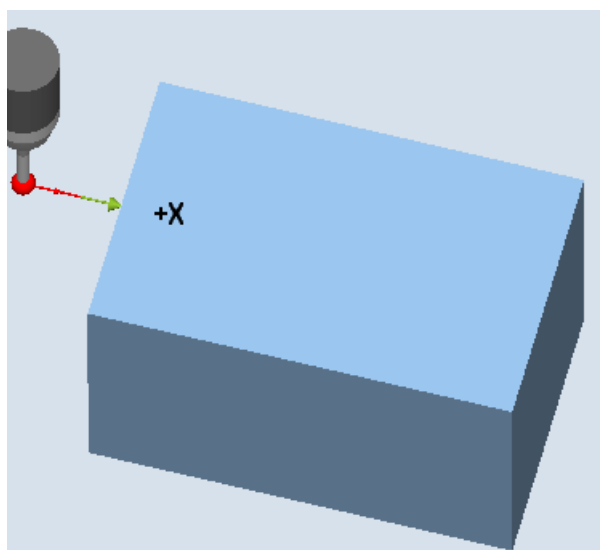

Figure 1-7 Measurement operation sequence, example set edge (CYCLE978)

The sequence is described using the measuring version, set edge (CYCLE978). The sequence is essentially the same for the other measuring cycles.

The **starting position** for the measuring procedure is the position **DFA** in front of the specified **set position** (expected contour).

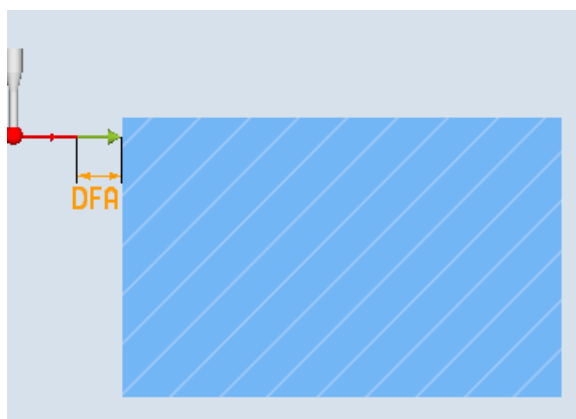

Figure 1-8 Starting position

The starting position is calculated in the cycle based on parameter entries and probe data. The traversing distance from the pre-position, defined by the user program, to the starting position of the measuring distance is either traversed with rapid traverse G0 or with positioning speed G1 (depending on the parameter). From the starting position, the **measuring velocity** is effective, which is saved in the calibration data.

The switching signal is expected along path $2 \cdot \text{DFA}$ as from the starting position. Otherwise, an alarm will be triggered or the measurement repeated.

The resulting **maximum measuring position** is available in the result parameters `_OVR[]` and `_OVI[]` of the measuring cycle.

1.8 Measurement principle

At the instant the switching signal is output by the probe, the current **actual position** is stored internally "on-the-fly" as the actual value, the measuring axis is stopped and then the "**Delete distance-to-go**" function is executed.

The distance-to-go is the path not yet covered in the measuring block. After deletion, the next block in the cycle can be processed. The measuring axis travels back to the starting position. Any measurement repetitions selected are restarted from this point.

Measurement path DFA

Measurement path DFA defines the distance between the starting position and the expected switching position (setpoint) of the probe.

Measuring velocity

As measuring feedrate, all of the measuring cycles use the value saved in the general setting data SD54611 after the calibration of the workpiece probe. A different measuring feedrate can be assigned for each calibration field [n].

To calibrate the measuring probe, either the measuring feedrate from the channel-specific setting data SD55630 \$SCS_MEA_FEED_MEASURE is used (default value: 300 mm/min) or the measuring feedrate can be overridden in the input screen form at the calibration instant. To do this, bit 4 must be set to 1 in the general setting data SD54760 \$SNS_MEA_FUNCTION_MASK_PIECE .

The **maximum permissible measuring velocity** is derived from:

- The deceleration behavior of the axis.
- The permissible deflection of the probe.
- The signal processing delay.

Deceleration distance, deflection of probe

CAUTION

Safe deceleration of the measuring axis to standstill within the permissible deflection path of the probe must always be ensured.

Otherwise damage will occur!

A delay t , typical for the control, is taken into account in signal processing (IPO cycle) for the time between detection of the switching signal and output of the deceleration command to the measuring axis: general machine data MD10050 \$MN_SYSCLOCK_CYCLE_TIME and MD10070 \$MN_IPO_SYSCLOCK_TIME_RATIO). This gives the braking distance component.

The following error of the measuring axis is reduced. The following error is velocity dependent and at the same time dependent on the control factor of the measuring axis (servo gain of the associated machine axis: servo gain factor).

The deceleration rate of the axis must also be taken into account.

Together they produce an axis-specific velocity-dependent deceleration distance.

The Kv factor is the axis MD 32200 \$MA_POSCTRL_GAIN.

The maximum axis acceleration / deceleration rate a is saved in axis MD 32300 \$MA_MAX_AX_ACCEL . It may have a lesser effect due to other influences.

Always use the lowest values of the axes involved in the measurement.

Measuring accuracy

A delay occurs between detection of the switching signal from the probe and transfer of the measured value to the control. This is caused by signal transmission from the probe and the hardware of the control. In this time a path is traversed that falsifies the measured value. This influence can be minimized by reducing the measuring speed.

The rotation when measuring a milling tool on a rotating spindle has an additional influence. This can be compensated using compensation tables.

The measurement accuracy that can be obtained is dependent on the following factors:

- Repeat accuracy of the machine
- Repeat accuracy of the probe
- Resolution of the measuring system

NOTICE

Precise measurement is only possible with a probe calibrated under the measurement conditions, i.e. working plane, orientation of the spindle in the plane and measuring velocity are the same for both measurement and calibration. Deviations result in measurement errors.

Calculation of the deceleration distance

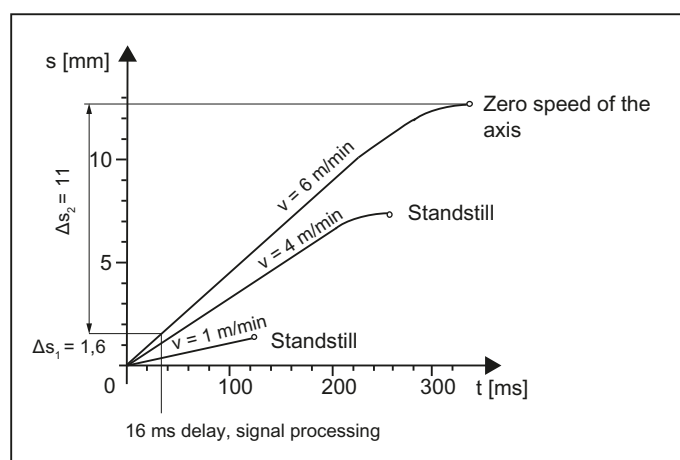

Figure 1-9 Distance-time diagram at different measuring velocities according to the calculation example

The deceleration path to be considered is calculated as follows:

$$s_b = \underbrace{v \cdot t}_{\Delta s_1} + \underbrace{\frac{v^2}{2a}}_{\Delta s_2} + \Delta s$$

s_b	Braking distance	in mm
v	Measuring velocity	in m/s
t	Delay signal	in s
a	Deceleration	in m/s ²
Δs	Following error	in mm
$\Delta s = v / K_v$		v here in m/min
K_v	Servo gain	in (m/min)/mm

Example of calculation:

- $v = 6 \text{ m/min} = 0.1 \text{ m/s}$ measuring velocity
- $a = 1 \text{ m/s}^2$ deceleration
- $t = 16 \text{ ms}$ signal delay
- $K_v = 1 \text{ in (m/min)/mm}$

Intermediate steps:

$\Delta s = v / K_v$	$= 6[\text{m/min}] / 1[(\text{m/min})/\text{mm}]$	$= 6 \text{ mm}$	Following error
$\Delta s_2 = v^2/2a$	$= 0,1 [\text{m/s}]^2 / 2 \cdot 1 [\text{m/s}^2]$	$= 5 \text{ mm}$	Axis-specific component
$\Delta s_1 = v \cdot t$	$= 0,1 [\text{m/s}] \cdot 0,016 [\text{s}]$	$= 1,6 \text{ mm}$	Percentage due to signal delay

Overall result:

$$s_b = \Delta s_1 + \Delta s_2 + \Delta s = 6 \text{ mm} + 5 \text{ mm} + 1,6 \text{ mm} = \mathbf{12,6 \text{ mm}}$$
 Braking distance

The deflection of the probe = braking distance to zero speed of the axis is **12.6 mm**.

1.9 Measuring strategy for measuring workpieces with tool offset

The actual workpiece dimensions must be measured exactly and compared with the setpoint values to be able to determine and compensate the actual dimensional deviations on the workpiece. An offset value can then be ascertained for the tool used for machining.

Function

When taking measurements on the machine, the actual dimensions are derived from the path measuring systems of the position-controlled feed axes. For each dimensional deviation determined from the set and actual workpiece dimensions there are many causes which essentially fall into three categories:

- **Dimensional deviations with causes that are not subject to a particular trend**, e.g. positioning scatter of the feed axes or differences in measurement between the internal measurement (probe) and the external measuring device (micrometer, measuring machine, etc.).

In this case, it is possible to apply **empirical values**, which are stored in separate memories. The set/actual difference determined is automatically compensated by the empirical value.

- **Dimensional deviations with causes that are subject to a particular trend**, e.g. tool wear or thermal expansion of the leadscrew.
- **Accidental dimensional deviations**, e.g. due to temperature fluctuations, coolant or slightly soiled measuring points.

Assuming the ideal case, only those dimensional deviations that are subject to a trend can be taken into account for compensation value calculation. Since, however, it is hardly ever known to what extent and in which direction accidental dimensional deviations influence the measurement result, a strategy (sliding averaging) is needed that derives a compensation value from the actual/set difference measured.

Mean value calculation

Mean value calculation in conjunction with measurement weighting has proven a suitable method.

When correcting a tool, it can be selected whether a correction is made based on the actual measurement, or whether an average value of the measurement differences should be generated over several measurements which is then used to make the correction.

The formula of the mean value generation chosen is:

$$MV_{\text{new}} = MV_{\text{old}} - \frac{MV_{\text{old}} - D_i}{k}$$

MV_{new}	Mean value new = amount of compensation
MV_{old}	Mean value prior to last measurement
k	Weighting factor for mean value calculation
D_i	Actual/set difference measured (minus any empirical value)

The mean value calculation takes account of the trend of the dimensional deviations of a machining series. The **weighting factor k** from which the mean value is derived is selectable.

A new measurement result affected by accidental dimensional deviations only influences the new tool offset to some extent, depending on the weighting factor.

Computational characteristic of the mean value with different weightings k

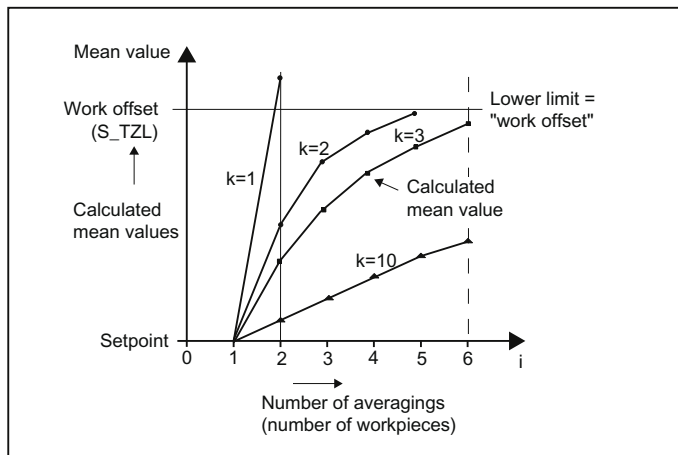

Figure 1-10 Mean value generation with influence of weighting k

- The greater the value of k, the slower the formula will respond when major deviations occur in computation or counter compensation. At the same time, however, accidental scatter will be reduced as k increases.
- The lower the value of k, the faster the formula will react when major deviations occur in computation or counter compensation. However, the effect of accidental variations will be that much greater.
- The mean value M_v is calculated starting at 0 over the number of workpieces i , until the calculated mean value exceeds the work offset range (S_{TZL}). From this limit on, the calculated mean value is applied as an offset.
- Once the mean value has been used for the offset, it is deleted from the memory. The next measurement then starts again with $M_{v_{old}} = 0$.

1.9 Measuring strategy for measuring workpieces with tool offset

Table 1- 1 Example of mean value calculation and offset

i	Lower limit = 40 μm (S_TZL = 0.04)			Characteristic of the mean value for two different weighting factors
	Di [μm]	Mv k = 3 [μm]	Mv k = 2 [μm]	
1. measurement	30	10	15	
2. Measurement	50	23,3	32,5	
3. Measurement	60	35,5	46,2 ③	
4. Measurement	20	30,3	10	
5. Measurement	40	32,6	25	
6. Measurement	50	38,4	37,5	
7. Measurement	50	42,3 ①	43,75 ④	
8. Measurement	30	10	15	
9. Measurement	70	30	42,5 ⑤	
10. Measurement	70	43,3 ②	35	

For the measurements with marked fields, tool offset is performed with the mean value (calculated mean value $>S_{TZL}$):

- If $k=3$ in the 7th and 10th measurement (① and ②),
- If $k=2$ in the 3rd, 7th, and 9th measurement (③, ④ and ⑤).

1.10 Parameters for checking the measurement result and offset

For constant deviations not subject to a trend, the dimensional deviation measured can be compensated by an empirical value in certain measuring variants.

For other compensations resulting from dimensional deviations, symmetrical tolerance bands are assigned to the set dimension which result in different responses.

Empirical value / mean value EVN (S_EVNUM)

The empirical values are used to suppress dimensional deviations that are **not subject to a trend**.

Note

If empirical values are not to be applied, then S_EVNUM = 0 must be set.

The empirical values themselves are saved in channel-specific SD 55623 \$SCS_MEA_EMPIRIC_VALUE .

EVN specifies the number of the empirical value memory. The actual/set difference determined by the measuring cycle is corrected by this value **before** any further correction measures are taken.

This is the case:

- For workpiece measurement with automatic tool offset.
- For single-point measurement with automatic WO correction.
- For tool measurement.

The mean value only refers to the workpiece measurement with automatic tool offset.

For an automatic tool offset, the mean value is generated from the measured difference of the previous and the actual measurement. This functionality has special significance within a machining series with measurements performed at the same measuring location.

The function does not have to be activated.

The mean values are stored in the channel-specific SD 55625 \$SCS_MEA_AVERAGE_VALUE . The number of the mean value memory is transferred in the measuring cycle using variable S_EVNUM.

Safe area TSA (S_TSA)

The safe area is effective for almost all measuring variants and does not affect the offset value; it is used for diagnostics.

If this limit is reached then the following can be assumed:

- A probe defect, or
- An incorrect setpoint position, or
- An illegal deviation from the setpoint position can be assumed.

Note**AUTOMATIC mode**

AUTOMATIC operation is interrupted and the program cannot continue. An alarm text appears to warn the user.

Dimension difference check DIF (S_TDIF)

DIF is active only for workpiece measurement with automatic tool offset and for tool measurement.

This limit has no effect on generation of the compensation value either. When it is reached, the tool is probably worn and needs to be replaced.

Note

An alarm text is displayed to warn the operator and the program can be continued by means of an NC start.

This tolerance limit is generally used by the PLC for tool management purposes (twin tools, wear monitoring).

Tolerance of workpiece: Lower limit (S_TLL), upper limit (S_TUL)

Both parameters are active only for tool measurement with automatic tool offset.

When measuring a dimensional deviation ranging between "2/3 tolerance of workpiece" and "Dimensional difference control", this is regarded 100% as tool offset. The previous average value is erased.

This enables a fast response to major dimensional deviations.

Note

When the tolerance limit of the workpiece is exceeded, this is indicated to the user depending on the tolerance position "oversize" or "undersize".

2/3 tolerance of workpiece TMV (S_TMV)

TMV is active only for workpiece measurement with automatic tool offset.

Within the range of "Lower limit" and "2/3 workpiece tolerance" the mean value is calculated according to the formula described in Section "Measuring strategy".

Note

MV_{new} is compared with the work offset range:

- If MV_{new} is **greater** than this range, compensation is corrected by MV_{new} and the associated mean value memory is cleared.
 - If MV_{new} is **less** than this range, no compensation is carried out. This prevents excessively abrupt compensations.
-

Weighting factor for mean value generation FW (S_K)

FW is active only for workpiece measurement with automatic tool offset. The weighting factor can be used to give a different weighting for each measurement.

A new measurement result thus has only a limited effect on the new tool offset as a function of FW.

Work offset range TZL (S_TZL)

TZL active for

- Workpiece measurement with automatic tool offset
- Tool measurement and calibration for milling tools and tool probes

This tolerance range corresponds to the amount of maximum accidental dimensional deviations. It has to be determined for each machine.

No tool compensation is made within these limits.

In workpiece measurement with automatic tool offset, however, the mean value of this measuring point is updated and re-stored with the measured actual/set difference, possibly compensated by an empirical value.

The tolerance bands (range of permissible dimensional tolerance) and the responses derived from them are as follows:

1.10 Parameters for checking the measurement result and offset

- For workpiece measurement with automatic tool offset

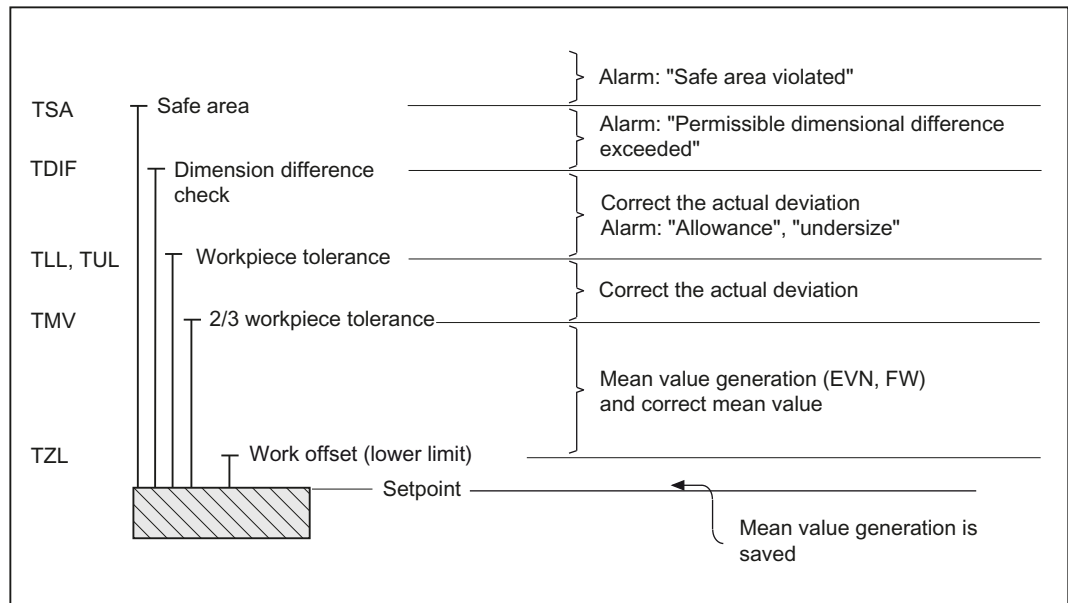

Note

In measuring cycles, the workpiece setpoint dimension is placed in the middle of the permitted \pm tolerance limit for reasons associated with symmetry.

- For tool measurement

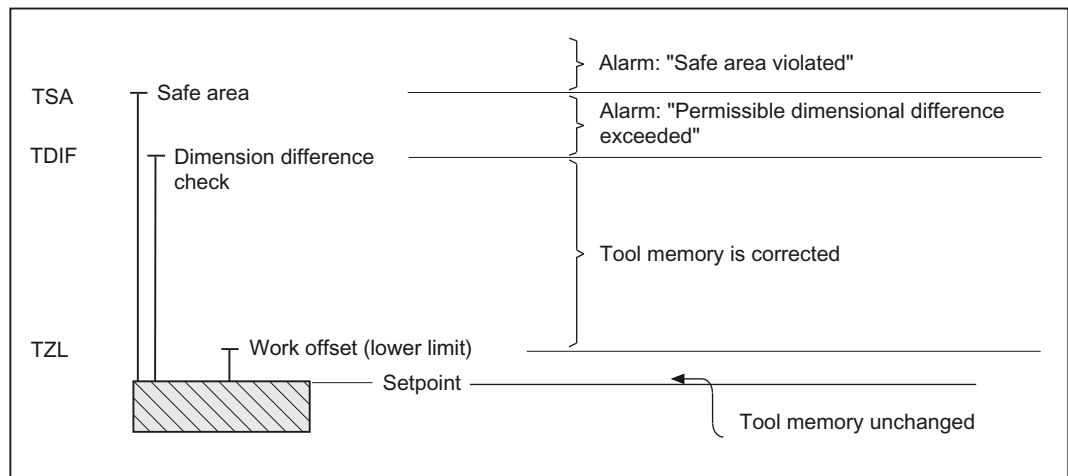

1.10 Parameters for checking the measurement result and offset

- For workpiece measurement with WO correction

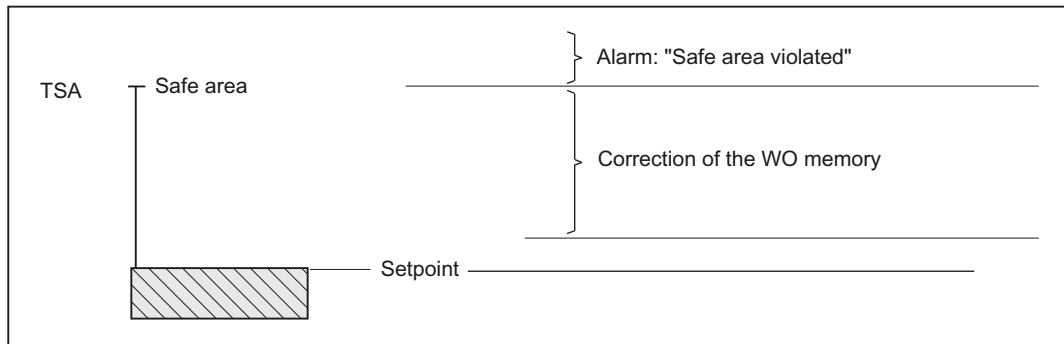

- For workpiece probe calibration

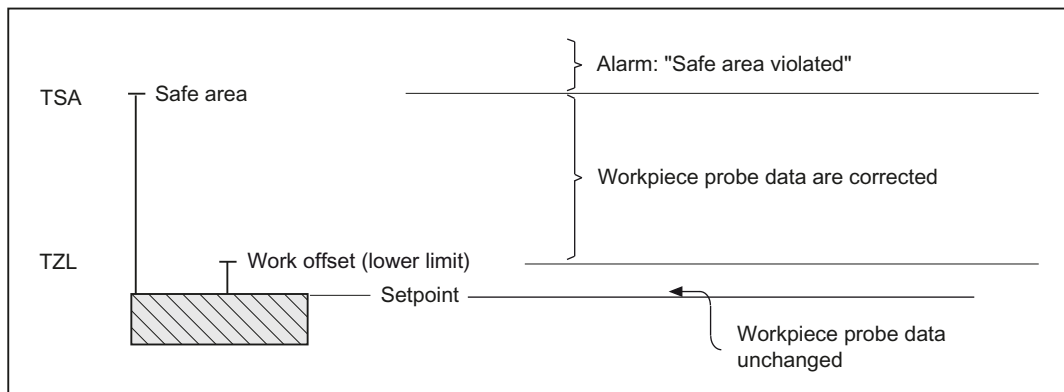

- For tool probe calibration

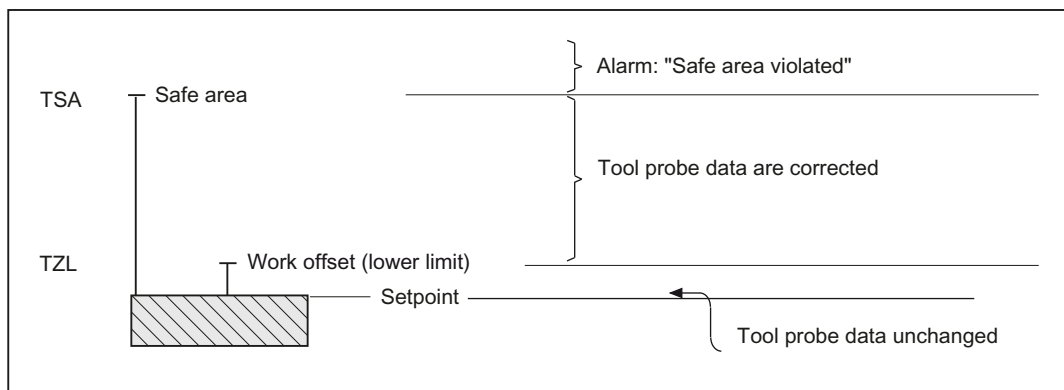

1.11 Effect of empirical value, mean value, and tolerance parameters

The following flowchart shows the effect of empirical value, mean value, and tolerance parameters on workpiece measurement with automatic tool offset.

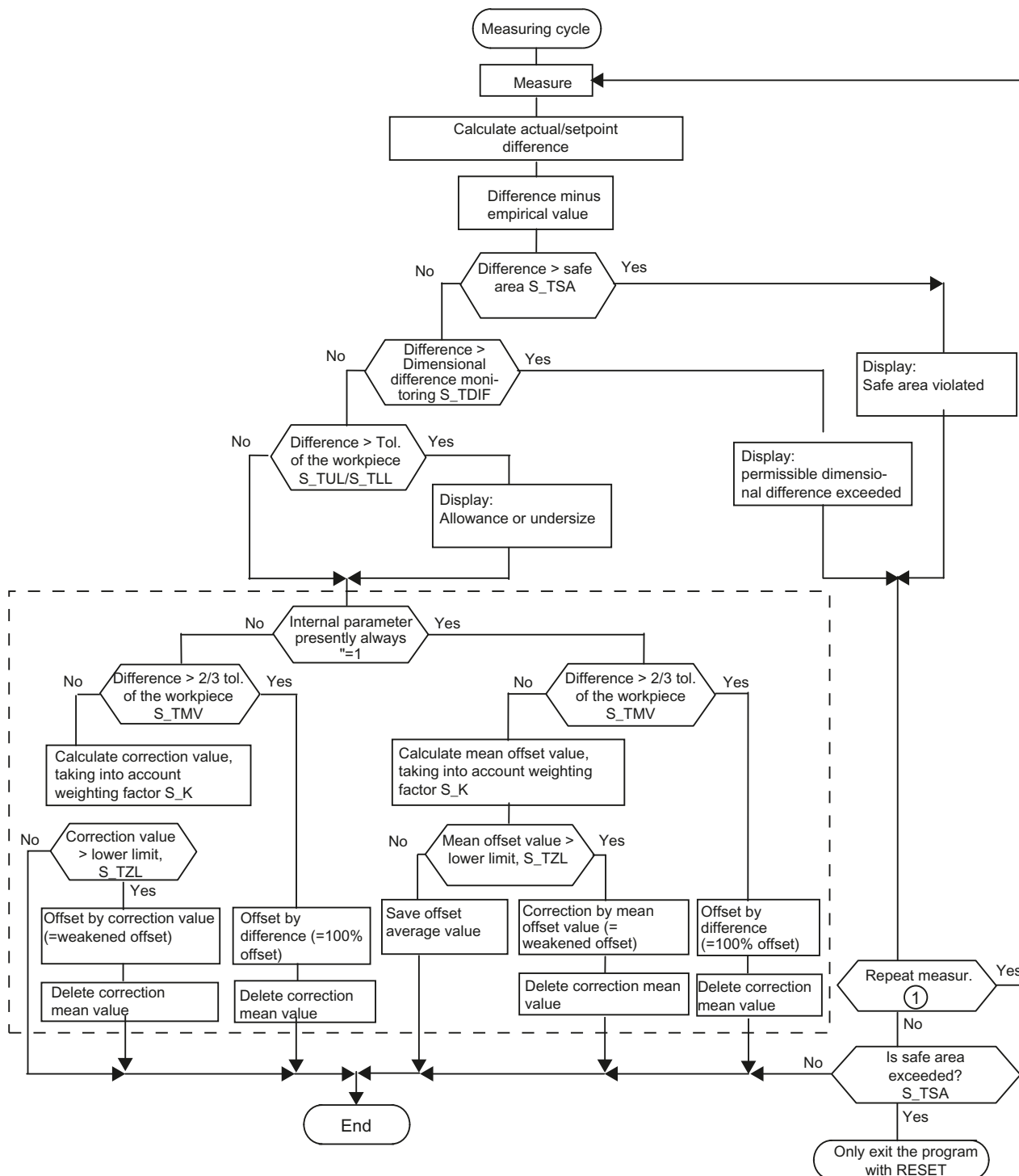

① SD 54740 \$SNS_MEA_FUNCTION_MASK, Bit 0

1.12 Measuring cycle help programs

1.12.1 CYCLE116: Calculation of center point and radius of a circle

Function

This cycle calculates from three or four points positioned on one plane the circle they inscribe with center point and radius.

To allow this cycle to be used as universally as possible, its data is transferred via a parameter list.

An array of REAL variables of length 13 must be transferred as the parameter.

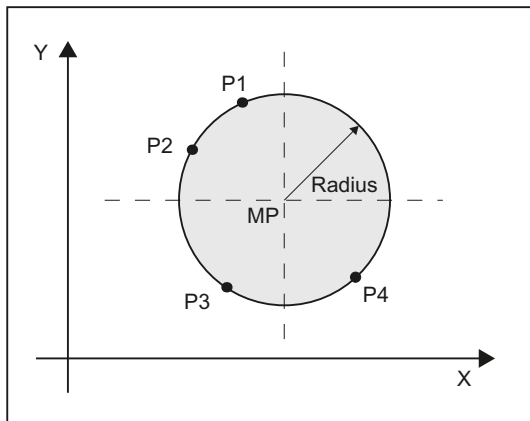

Figure 1-11 Calculation of circle data from 4 points

Programming

```
CYCLE116 (_CAL[ ], _MODE)
```

Transfer parameters

- Input data

Parameters	Data type	Meaning
_CAL [0]	REAL	Number of points for calculation (3 or 4)
_CAL [1]	REAL	1. Axis of the plane of the first point
_CAL [2]	REAL	2. Axis of the plane of the first point
_CAL [3]	REAL	1. Axis of the plane of the second point
_CAL [4]	REAL	2. Axis of the plane of the second point
_CAL [5]	REAL	1. Axis of the plane of the third point
_CAL [6]	REAL	2. Axis of the plane of the third point
_CAL [7]	REAL	1. Axis of the plane of the fourth point
_CAL [8]	REAL	2. Axis of the plane of the fourth point

- Output data

Parameters	Data type	Meaning
_CAL [9]	REAL	1. Axis of the plane of the circle center point
_CAL [10]	REAL	2. Axis of the plane of the circle center point
_CAL [11]	REAL	Circle radius
_CAL [12]	REAL	Status for the calculation 0 = Calculation in progress 1 = Error occurred
_MODE	INTEGER	Error number (61316 or 61317 possible)

Note

This cycle is called as a subroutine by, for example, measuring cycle CYCLE979.

Example

```

%_N_Circle_MPF
DEF INT _MODE
DEF REAL _CAL[13]= (3,0,10,-10,0,0,-10,0,0,0,0,0,0)           ;3 points specified      P1: 0,10
                                                                P2: -10,0
                                                                P3: 0,-10
CYCLE116(_CAL[ ], _MODE)                                     ;Result:                _CAL[9]=0
                                                                _CAL[10]=0
                                                                _CAL[11]=10
                                                                _CAL[12]=0
                                                                _ALM=0
M0
STOPRE
M30

```

1.12.2 CUST_MEACYC: User program before/after measurements are performed

Function

The CUST_MEACYC cycle is called at the beginning of each measuring cycle.

It can be used by users to program sequences necessary before starting a measurement (e.g. to activate probe).

In the as-delivered state, this cycle only contains one CASE statement that executes a jump to a label with subsequent M17 (end of subroutine) for each measuring cycle.

Example

```
_M977:      ;before measurement in CYCLE977  
M17        ;end of cycle
```

From this label all actions to be executed on each CYCLE977 call must be programmed.

References

Commissioning manual *SINUMERIK 840D sl Basesoftware and Operating Software*.

1.13 Miscellaneous functions

1.13.1 Measuring cycle support in the program editor

The program editor offers extended measuring cycle support for inserting measuring cycle calls into the program.

Prerequisite

Hardware TCU or PCU.

Function

This measuring cycle support provides the following functionality:

- Measuring cycle selection via softkeys
- Input screen forms for parameter assignment with help displays
- Retranslatable program code is generated from the individual screen forms.

1.13.2 Measuring result screens

Function

Measurement result displays can be shown automatically during a measuring cycle. In the channel-specific SD 55613 \$SCS_MEA_RESULT_DISPLAY, you can select between the following measurement result screens:

- = 0 The measurement results screen is not displayed (default setting)
- = 1 The measurement results screen is displayed for 8 seconds.
- = 3 The measuring cycle stops at the NC command "M0", the measuring results screen is statically displayed.
The measuring cycle is continued with NC Start, the measuring results screen is deselected.
- = 4 The measuring results screen is only displayed for cycle alarms 61303, 61304, 61305 and 61306.
The measuring cycle is continued with NC Start, the measuring results screen is deselected.

The measuring cycles can display different measuring result screens depending on the measuring variant:

- Calibrating tool probes
- Tool measurement
- Calibrating workpiece probes
- Workpiece measurement

Displaying measuring results screens

The measuring results screens contain the following data:

Calibrating tool probes

- Measuring cycle and measuring version
- Trigger values of axis directions and differences
- Probe number
- Safe area

Tool measurement

- Measuring cycle and measuring version
- Actual values and differences for tool offsets
- Safe area and permissible dimensional difference
- T name, D number

Calibrating workpiece probes

- Measuring cycle and measuring version
- Trigger values of axis directions and differences
- Position deviation (probe skew) when calibrating in the plane
- Probe number
- Safe area

Workpiece measurement

- Measuring cycle and measuring version
- Setpoints, actual values and their differences
- Tolerance upper and lower limits (for tool offset)
- Offset value
- Probe number
- Safe area and permissible dimensional difference
- T name, D number and DL number or WO memory number for automatic offset

Example of measurement result display

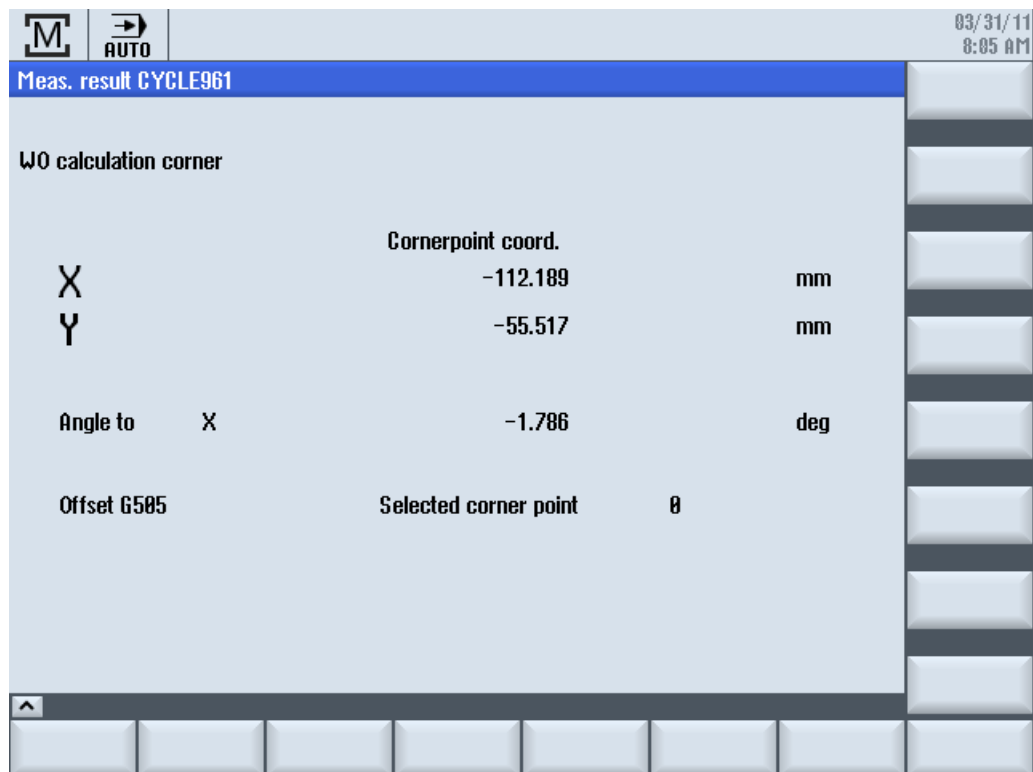

Measuring variants

2.1 General requirements

2.1.1 Overview of the measuring cycles

Function of the measuring cycles

The following table describes all the measuring cycle functions for the turning and milling technologies.

Table 2- 1 Measuring cycles

Measuring cycle	Description	Measuring versions
CYCLE973 ²⁾	This measuring cycle can be used to calibrate a workpiece probe on a surface on the workpiece or in a groove.	<ul style="list-style-type: none"> • Calibrate probe - length • Calibrate probe - radius on surface • Calibrate probe - probe in groove
CYCLE974 ²⁾	This measuring cycle can be used to determine the workpiece zero in the selected measuring axis or a tool offset with 1-point measurement.	<ul style="list-style-type: none"> • Turning measurement - front edge • Turning measurement - inside diameter • Turning measurement - outside diameter
CYCLE994 ²⁾	This measuring cycle can be used to determine the workpiece zero in the selected measuring axis with 2-point measurement. To do this, two opposite measuring points on the diameter are approached automatically in succession	<ul style="list-style-type: none"> • Turning measurement - inside diameter • Turning measurement - outside diameter
CYCLE976	Using this measuring cycle, a workpiece probe can be calibrated in a calibration ring or on a calibration ball completely in the working plane or at an edge for a particular axis and direction.	<ul style="list-style-type: none"> • Calibrate probe - length on surface • Calibrate probe - radius in ring • Calibrate probe - radius on edge • Calibrate probe - calibration on sphere
CYCLE961	This measuring cycle can be used to determine the position of a workpiece corner (inner or outer) and use this as work offset.	<ul style="list-style-type: none"> • Corner - right-angled corner • Corner - any corner
CYCLE977	This measuring cycle can be used to determine the center point in the plane as well as the width or the diameter.	<ul style="list-style-type: none"> • Edge distance - groove • Edge distance - rib • Hole - rectangular pocket • Hole - 1 hole • Spigot - rectangular spigot • Spigot - 1 circular spigot

2.1 General requirements

Measuring cycle	Description	Measuring versions
CYCLE978	This measuring cycle can be used to measure the position of an edge in the workpiece coordinate system.	Edge distance - set edge
CYCLE979	This measuring cycle can be used to measure the center point in the plane and the radius of circle segments.	<ul style="list-style-type: none"> • Hole - inner circle segment • Spigot - outer circle segment
CYCLE995	With this measuring cycle the angularity of the spindle on a machine tool can be measured.	3D - angular deviation spindle
CYCLE996	This measuring cycle can be used to determine transformation-relevant data for kinematic transformations with contained rotary axes.	3D - kinematics
CYCLE997	This measuring cycle can be used to determine the center point and diameter of a ball. Furthermore, the center points of three distributed balls can be measured. The plane formed through the three ball center points, regarding its angular position, is determined referred to the working plane in the workpiece coordinate system.	<ul style="list-style-type: none"> • 3D - sphere • 3D - 3 spheres
CYCLE998	This measuring cycle can be used to determine the angular position of a surface (plane) referred to the working plane and the angle of edges in the workpiece coordinate system.	<ul style="list-style-type: none"> • Edge distance - align edge • 3D - align plane
CYCLE971 ¹⁾	This measuring cycle can be used to calibrate a tool probe and measure the tool length and/or tool radius for milling tools.	<ul style="list-style-type: none"> • Calibrate probe • Measure tool
CYCLE982 ²⁾	This measuring cycle can be used to calibrate a tool probe and measure turning, drilling and milling tools on turning machines.	<ul style="list-style-type: none"> • Calibrate probe • Turning tool • Milling tool • Drill

1) Only for milling technology

2) Only for turning technology

2.1.2 Selection of the measuring variants via softkeys (turning)

The following shows the measuring variants of the turning technology as a menu tree.









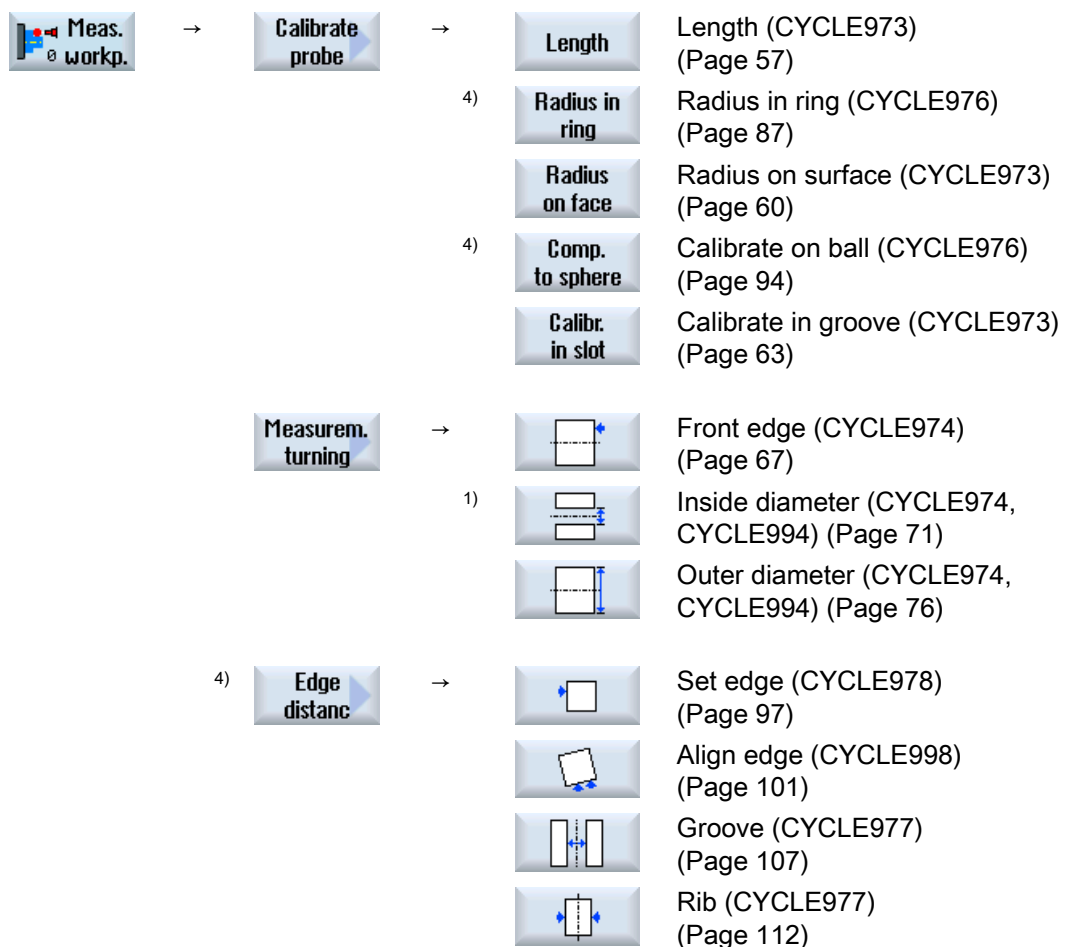











Preconditions

All of the measuring variants available in the control are shown in the display. However, on a specific system, only those steps can be selected that are possible for the set extended technology.

- 1) The "Inside diameter" softkey is displayed if bit1 =1 is set in the general SD 54764 \$SNS_MEA_FUNCTION_MASK_TURN.
- 2) The "3D" softkey is displayed if bit 1 = 1 is set in the general SD 54760 \$SNS_MEA_FUNCTION_MASK_PIECE.
- 3) The "kinematics" softkey is only displayed in the G code program, if the "Measure kinematics" option is set.
- 4) These softkeys are displayed if the "Milling" extended technology is set (channel-specific MD 52201 \$MCS_TECHNOLOGY_EXTENSION = 2).

Turning technology menu tree



4) 	→		Right-angled corner (CYCLE961) (Page 116)
			Any corner (CYCLE961) (Page 120)
4) 	→		Rectangular pocket (CYCLE977) (Page 124)
			1 hole (CYCLE977) (Page 128)
			Inner circle segment (CYCLE979) (Page 132)
4) 	→		Rectangular spigot (CYCLE977) (Page 136)
			1 circular spigot (CYCLE977) (Page 140)
			Outer circle segment (CYCLE979) (Page 144)
2), 4) 	→		Align plane (CYCLE998) (Page 148)
			Sphere (CYCLE997) (Page 152)
			3 spheres (CYCLE997) (Page 156)
	3)		Kinematics (CYCLE996) (Page 165)
	→		Calibrate probe (CYCLE982) (Page 184)
			Turning tool (CYCLE982) (Page 188)
	4)		Milling tool (CYCLE982) (Page 192)
			Drill (CYCLE982) (Page 199)

2.1.3 Selection of the measuring variants via softkeys (milling)

The following shows the measuring variants for the milling technology as a menu tree.









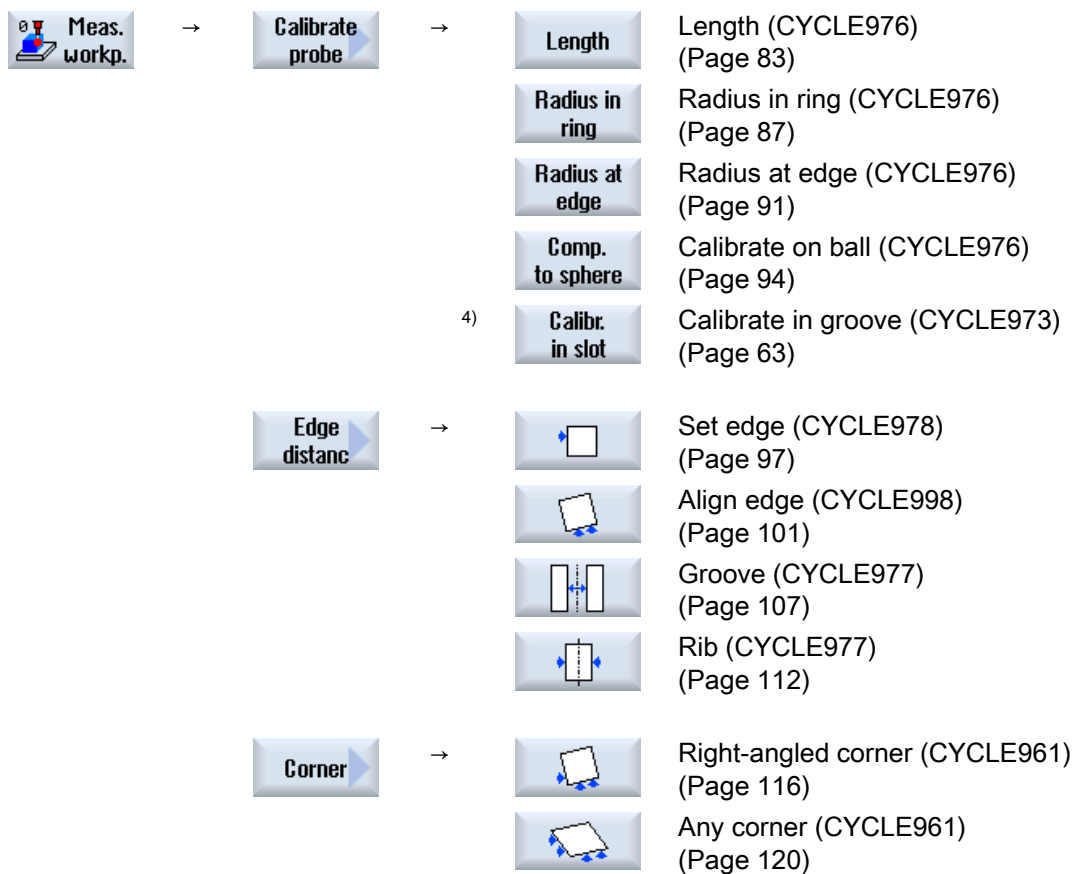











Preconditions

All of the measuring variants available in the control are shown in the display. However, on a specific system, only those steps can be selected that are possible for the set extended technology.

- 1) The "Inside diameter" softkey is displayed if bit1 =1 is set in the general SD 54764 \$SNS_MEA_FUNCTION_MASK_TURN .
- 2) The "3D" softkey is displayed if bit 1 = 1 is set in the general SD 54760 \$SNS_MEA_FUNCTION_MASK_PIECE .
- 3) The "kinematics" softkey is only displayed in the G code program, if the "Measure kinematics" option is set.
- 4) These softkeys are only displayed in the G code program if the "turning" extended technology is set (channel-specific MD 52201 \$MCS_TECHNOLOGY_EXTENSION = 1).
- 5) The softkey "angular deviation spindle" is exclusively displayed in the G code program.

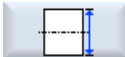
Milling technology menu tree



		→		Rectangular pocket (CYCLE977) (Page 124)
				1 hole (CYCLE977) (Page 128)
				Inner circle segment (CYCLE979) (Page 132)
		→		Rectangular spigot (CYCLE977) (Page 136)
				1 circular spigot (CYCLE977) (Page 140)
				Outer circle segment (CYCLE979) (Page 144)
2)		→		align plane (CYCLE998) (Page 148)
				Sphere (CYCLE997) (Page 152)
				3 spheres (CYCLE997) (Page 156)
		5)		Angular deviation spindle (CYCLE995) (Page 161)
		3)		Kinematics (CYCLE996) (Page 165)
4)		→		Set front edge (CYCLE974) (Page 67)
		1)		Inside diameter (CYCLE974, CYCLE994) (Page 71)
				Outer diameter (CYCLE974, CYCLE994) (Page 76)
		→		Calibrate probe (CYCLE971) (Page 208)
				Measure tool (CYCLE971) (Page 214)

2.1.4 Result parameters

Definition

Result parameters are measurement results provided by the measuring cycles.

Parameters	Type	Meaning
_OVR[]	REAL	Result parameter - real number: Setpoint values, actual values, differences, offset values, etc.
_OVI[]	INTEGER	Result parameter - integer

Call

The result parameters of the measuring cycles are saved in the channel-specific user variables. These can be called from the operating area as follows:



1. Press the "Parameter" softkey.



2. Press the the "Channel GUD" softkey.



3. Press the "Using variable" softkey.

The result parameters _OVR[] and _OVI[] are displayed in the "Channel-specific user variables" window.

Measuring versions

Which result parameters are output from the measuring cycles, is described in the individual measuring versions.

For workpiece measurement with tool offset or offset in the WO, several measuring versions also supply result parameters, see Chapter Additional result parameters (Page 265).

2.2 Measure workpiece (turning)

2.2.1 General information

The measuring cycles below are intended for use on turning machines.

Note

Spindle

Spindle commands in the measuring cycles always refer to the active master spindle of the control.

When using the measuring cycles at machines with several spindles, then the spindle involved must be defined as master spindle before the cycle call.

NOTICE
Precise measurement is only possible with a probe calibrated under the measurement conditions, i.e. working plane and measuring velocity are the same for both measurement and calibration.
If the probe is used in the spindle for a driven tool, the spindle orientation must also be considered. Deviations can cause measuring errors.

References: /PG/ Programming Manual *SINUMERIK 840D sl / 828D Fundamentals*

Plane definition

The measuring cycles work internally with the 1st and 2nd axes of the actual plane G17 to G19.

The default setting for lathes is G18.

For information regarding measurement in conjunction with a 3rd axis, see Chapter Extended measurement (Page 81).

Note

A correspondence/assignment list of the measuring cycle parameters, machine and setting data used with regard to the measuring cycle versions V7.05, V2.06 and V4.04 can be found in the Appendix Changes from cycle version SW4.4 and higher (Page 267)!

2.2.2 Calibrate probe - length (CYCLE973)

Function

With this measuring version, a workpiece probe with cutting edge positions SL=5 to 8 can be calibrated on a known surface (workpiece-related). The trigger points of the probe are determined.

Optionally, the actual length can be entered in the tool offset memory via the "Adapt tool length" parameter.

Measuring principle

The switching position of the workpiece probe in an axis is calculated into the measuring probe length. The calculated trigger point is determined in the corresponding axis and axis direction, and entered in the selected calibration data set (calibration data field) of the workpiece probe.

The probe travels in the measuring direction to the calibration edge (e.g. workpiece)

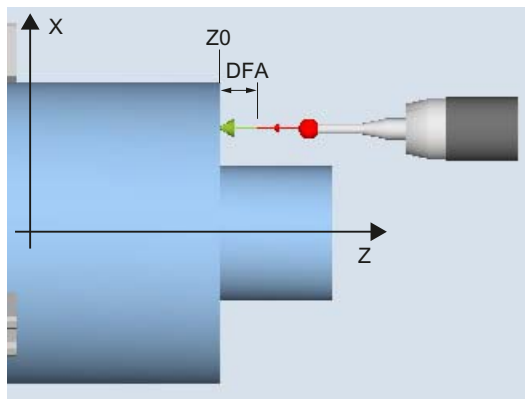

Figure 2-1 Calibrate: Length on the surface (CYCLE973), example G18, SL=7

Requirements

- The surface must be in parallel to an axis of the workpiece coordinate system (WCS).
- The calibration surface must have a low surface roughness.
- The workpiece probe is called as tool with tool offset.
- 580 must be declared as the probe type.

Starting position before the measurement

The probe must be positioned opposite to the calibration surface.

Position after the end of the measuring cycle

The probe is at the distance of the selected measurement path (DFA) away from the calibration surface.

Procedure

The part program or ShopTurn program to be processed has been created and you are in the editor.



1. Press the "Meas. workpiece" softkey.
2. Press the "Calibrate probe" softkey.
3. Press the "Length" softkey.
The input window "Calibrate: length at surface" is opened.

Parameters

G code program			ShopTurn program		
Parameters	Description	Unit	Parameters	Description	Unit
	Calibration data set (1 - 12)	-	T	Name of the probe	-
F	Calibration and measuring feedrate	Distance/min	D	Cutting edge number (1 - 9)	-
				Calibration data set (1 - 12)	-
			β	Tool alignment with swivel axis <ul style="list-style-type: none"> • ← (0 degrees) • ↓ (90 degrees) • Value entry 	Degrees
			F	Calibration and measuring feedrate	mm/min
			Z	Start point Z of the measurement	mm
			X	Start point X of the measurement	mm
			Y	Start point Y of the measurement	mm

Parameters	Description	Unit
Adapt tool length	Adapt the probe length and trigger point: <ul style="list-style-type: none"> • Yes • No (adapt trigger point only) 	-
Measuring direction	Measuring axis (for G18): <ul style="list-style-type: none"> • +/- Z • +/- X 	-
Z0 / X0	Reference point Z/X (corresponding to the measuring direction)	mm
DFA	Measurement path	mm
TSA	Safe area for the measurement result	mm

NOTICE
When the calibration is performed for the first time, the default setting in the data field of the probe is still "0". For this reason, the TSA parameter must be programmed > probe ball radius to avoid the alarm "Safe area exceeded".

List of the result parameters

The measuring version "Length" provides the following result parameters:

Table 2- 2 "Length" result parameters

Parameters	Description	Unit
_OVR [4]	Actual value probe ball diameter	mm
_OVR [5]	Difference probe ball diameter	mm
_OVR [8]	Trigger point in minus direction, actual value of 1st axis of the plane	mm
_OVR [10]	Trigger point in plus direction, actual value of 1st axis of the plane	mm
_OVR [12]	Trigger point in minus direction, actual value of 2nd axis of the plane	mm
_OVR [14]	Trigger point in plus direction, actual value of 2nd axis of the plane	mm
_OVR [9]	Trigger point in minus direction, difference of 1st axis of the plane	mm
_OVR [11]	Trigger point in plus direction, difference of 1st axis of the plane	mm
_OVR [13]	Trigger point in minus direction, difference of 2nd axis of the plane	mm
_OVR [15]	Trigger point in plus direction, difference of 2nd axis of the plane	mm
_OVR [20]	Positional deviation of the 1st axis of the plane (probe skew)	mm
_OVR [21]	Positional deviation of the 2nd axis of the plane (probe skew)	mm
_OVR [27]	Work offset range	mm
_OVR [28]	Safe area	mm
_OVI [2]	Measuring cycle number	-
_OVI [5]	Probe number	-
_OVI [9]	Alarm number	-

2.2.3 Calibrate probe - radius on surface (CYCLE973)

Function

With this measuring version, the radius of a workpiece probe with cutting edge positions SL=5 to 8 can be calibrated on a surface. The trigger points of the probe are determined.

The calibration surface is workpiece-related. It is only possible to calibrate in the selected axis and direction, which are perpendicular to this calibration surface.

Measuring principle

The determined switching position of the workpiece probe in the parameterized axis and direction, is calculated with the setpoint of the reference surface and from this the corresponding trigger point determined.

If no alarms occur, the trigger values are entered into the selected calibration data set of the workpiece probe.

The probe travels in the measuring direction to the reference surface (e.g. workpiece)

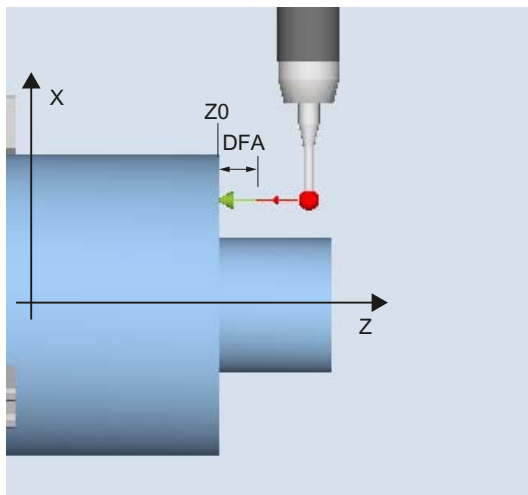

Figure 2-2 Calibrate: radius at the surface (CYCLE973), example G18, SL=8

Requirements

- The surface must be in parallel to an axis of the workpiece coordinate system (WCS).
- The calibration surface must have a low surface roughness.
- The workpiece probe is called as tool with tool offset.
- 580 must be declared as the probe type.

Starting position before the measurement

The probe must be positioned opposite to the calibration surface.

Position after the end of the measuring cycle

The probe (ball radius) is the distance of the measurement path away from the calibration surface.

Procedure

The part program or ShopTurn program to be processed has been created and you are in the editor.



1. Press the "Meas. workpiece" softkey.



2. Press the "Calibrate probe" softkey.



3. Press the "Radius on surface" softkey.

The input window "Calibrate: radius at surface" is opened.

Parameters

G code program			ShopTurn program		
Parameters	Description	Unit	Parameters	Description	Unit
	Calibration data set (1 - 12)	-	T	Name of the probe	-
F	Calibration and measuring feedrate	Distance/min	D	Cutting edge number (1 - 9)	-
				Calibration data set (1 - 12)	-
			F	Calibration and measuring feedrate	mm/min
			β	Tool alignment with swivel axis <ul style="list-style-type: none"> • ← (0 degrees) • ↓ (90 degrees) • Value entry 	Degrees
			X	Start point X of the measurement	mm
			Y	Start point Y of the measurement	mm
			Z	Start point Z of the measurement	mm

Parameters	Description	Unit
Measuring direction 	Measuring axis (for measuring plane G18) <ul style="list-style-type: none"> • +/- Z • +/- X 	-
Z0 / X0	Reference point Z/X (corresponding to the measuring direction)	mm
DFA	Measurement path	mm
TSA	Safe area for the measurement result	mm

NOTICE
When the calibration is performed for the first time, the default setting in the data field of the probe is still "0". For this reason, the TSA parameter must be programmed > probe ball radius to avoid the alarm "Safe area exceeded".

List of the result parameters

The measuring variant "Radius on surface" provides the following result parameters:

Table 2- 3 "Radius on surface" result parameters

Parameters	Description	Unit
_OVR [4]	Actual value probe ball diameter	mm
_OVR [5]	Difference probe ball diameter	mm
_OVR [8]	Trigger point in minus direction, actual value of 1st axis of the plane	mm
_OVR [10]	Trigger point in plus direction, actual value of 1st axis of the plane	mm
_OVR [12]	Trigger point in minus direction, actual value of 2nd axis of the plane	mm
_OVR [14]	Trigger point in plus direction, actual value of 2nd axis of the plane	mm
_OVR [9]	Trigger point in minus direction, difference of 1st axis of the plane	mm
_OVR [11]	Trigger point in plus direction, difference of 1st axis of the plane	mm
_OVR [13]	Trigger point in minus direction, difference of 2nd axis of the plane	mm
_OVR [15]	Trigger point in plus direction, difference of 2nd axis of the plane	mm
_OVR [20]	Positional deviation of the 1st axis of the plane (probe skew)	mm
_OVR [21]	Positional deviation of the 2nd axis of the plane (probe skew)	mm
_OVR [27]	Zero offset area	mm
_OVR [28]	Safe area	mm
_OVI [2]	Measuring cycle number	-
_OVI [5]	Probe number	-
_OVI [9]	Alarm number	-

2.2.4 Calibrate probe - calibrate in groove (CYCLE973)

Function

Using this measuring version, a workpiece probe with cutting edge position SL=7 or SL=8 can be calibrated in a reference groove machine-related in the axes of the plane. The measuring probe length or the probe ball radius can be determined with the calibration.

With the radius determination, a calibration is possible in one direction or in opposite directions of an axis. It is also possible to determine the positional deviation (skew) of the probe and the effective diameter of the probe ball during calibration in opposite directions.

Measuring principle

The measured switching positions of the workpiece probe in the parameterized axis are taken into account together with the machine-related data of the selected calibration groove. From this data, the trigger points are calculated in the positive and negative directions as well as the position deviation in this axis and the effective probe ball diameter. The trigger points always refer to the center of the probe ball (TCP).

The probe moves in the selected measuring axis in both directions in the calibration groove.

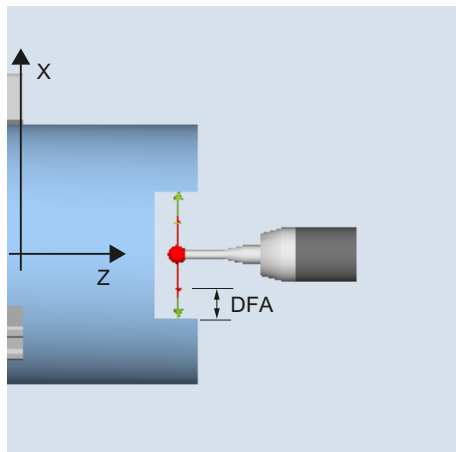

Calibrate: Probe in groove (CYCLE973),
example G18, SL=7

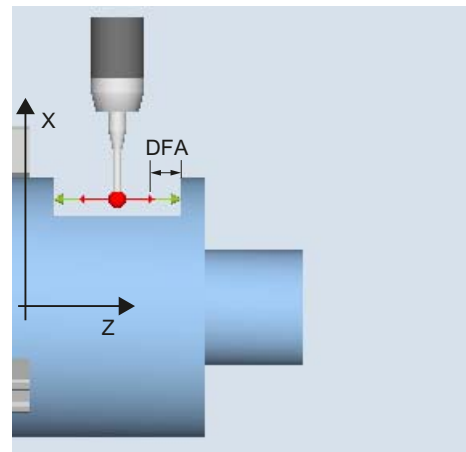

Calibrate: Probe in groove (CYCLE973),
example G18, SL=8

Requirements

- The workpiece probe must be called as tool with the associated tool offset.
- The machine-related geometrical dimensions of the selected calibration group must be saved before calibration in the corresponding general setting data.

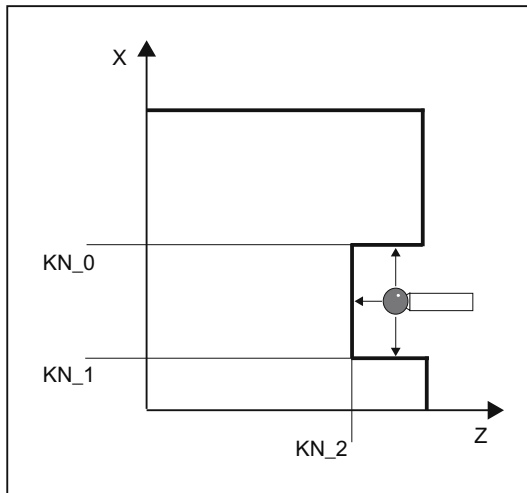

Geometry of the calibration groove, example G18, SL=7

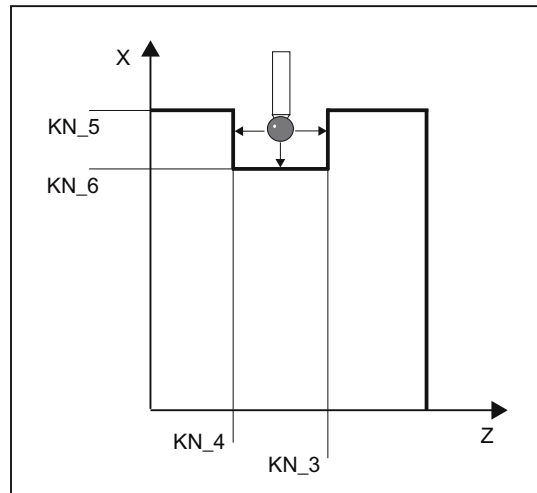

Geometry of the calibration groove, example G18, SL=8

Table 2- 4 General setting data for dimensions of the calibration groove

Calibration groove	General setting data	Description
KN_0	SD 54621 \$SNS_MEA_CAL_EDGE_PLUS_DIR_AX2	Calibration groove edge in the positive direction of the 2nd measuring axis.
KN_1	SD 54622 \$SNS_MEA_CAL_EDGE_MINUS_DIR_AX2	Calibration groove edge in the negative direction of the 2nd measuring axis.
KN_2	SD 54615 \$SNS_MEA_CAL_EDGE_BASE_AX1	Calibration groove base of the 1st measuring axis
KN_3	SD 54617 \$SNS_MEA_CAL_EDGE_PLUS_DIR_AX1	Calibration groove edge in the positive direction of the 1st measuring axis
KN_4	SD 54618 \$SNS_MEA_CAL_EDGE_MINUS_DIR_AX1	Calibration groove edge in the negative direction of the 1st measuring axis.
KN_5	SD 54620 \$SNS_MEA_CAL_EDGE_UPPER_AX2	Upper calibration groove edge of the 2nd measuring axis
KN_6	SD 54619 \$SNS_MEA_CAL_EDGE_BASE_AX2	Calibration groove base of the 2nd measuring axis

References: Commissioning Manual *SINUMERIK Operate (IM9) / SINUMERIK 840D sl*, Chapter "Measuring workpieces when turning".

Starting position before the measurement

The starting point should be selected so that the selected workpiece probe can be positioned in the shortest possible distance, collision-free, with paraxial movements, in the reference groove corresponding to the active cutting edge position.

Position after the end of the measuring cycle

When calibration has been completed, the probe is positioned at the measurement distance (DFA) from the calibration surface.

Procedure

The part program or ShopTurn program to be processed has been created and you are in the editor.



1. Press the "Meas. workpiece" softkey.



2. Press the "Calibrate probe" softkey.



3. Press the "Calibrate in groove" softkey.

The input window "Calibrate: probe in groove" is opened.

Parameters

G code program			ShopTurn program		
Parameters	Description	Unit	Parameters	Description	Unit
PL	Measuring plane (G17 - G19)	-	T	Name of the probe	-
	Calibration data set (1 - 12)	-	D	Cutting edge number (1 - 9)	-
F	Calibration and measuring feedrate	Distance/min		Calibration data set (1 - 12)	-
			β	Tool alignment with swivel axis <ul style="list-style-type: none"> • (0 degrees) • (90 degrees) • Value entry 	Degrees
			F	Calibration and measuring feedrate	mm/min
			X	Start point X of the measurement	mm
			Y	Start point Y of the measurement	mm
			Z	Start point Z of the measurement	mm

Parameters	Description	Unit
Calibrate	<ul style="list-style-type: none"> • Length (calibrate probe length) • Radius (calibrate probe radius) 	-
Calibration directions (only for "Radius" calibration)	<ul style="list-style-type: none"> • 1: Calibration in one direction • 2: Calibration in opposite directions 	-
Measuring direction	Measuring axis (corresponding to the measuring plane): <ul style="list-style-type: none"> • (+/-) Z • (+/-) X 	-
Adapt tool length (only for "Length" calibration)	<ul style="list-style-type: none"> • No (adapt trigger point only) • Yes (adapt probe length and trigger point) 	-

Parameters	Description	Unit
Calibration groove data set 	<ul style="list-style-type: none"> • 1 • 2 • 3 	-
DFA	Measurement path	mm
TSA	Safe area for the measurement result	mm

NOTICE

When the calibration is performed for the first time, the default setting in the data field of the probe is still "0". For this reason, the **TSA** parameter must be programmed > probe ball radius to avoid the alarm "Safe area exceeded".

List of the result parameters

The measuring variant "Calibrate in groove" provides the following result parameters:

Table 2- 5 "Calibrate in groove" result parameters

Parameters	Description	Unit
_OVR [4]	Actual value probe ball diameter	mm
_OVR [5]	Difference probe ball diameter	mm
_OVR [8]	Trigger point in minus direction, actual value of 1st axis of the plane	mm
_OVR [10]	Trigger point in plus direction, actual value of 1st axis of the plane	mm
_OVR [12]	Trigger point in minus direction, actual value of 2nd axis of the plane	mm
_OVR [14]	Trigger point in plus direction, actual value of 2nd axis of the plane	mm
_OVR [9]	Trigger point in minus direction, difference of 1st axis of the plane	mm
_OVR [11]	Trigger point in plus direction, difference of 1st axis of the plane	mm
_OVR [13]	Trigger point in minus direction, difference of 2nd axis of the plane	mm
_OVR [15]	Trigger point in plus direction, difference of 2nd axis of the plane	mm
_OVR [20]	Positional deviation of the 1st axis of the plane (probe skew)	mm
_OVR [21]	Positional deviation of the 2nd axis of the plane (probe skew)	mm
_OVR [27]	Work offset range	mm
_OVR [28]	Safe area	mm
_OVI [2]	Measuring cycle number	-
_OVI [5]	Probe number	-
_OVI [9]	Alarm number	-

2.2.5 Turning measurement - front edge (CYCLE974)

Function

With this measuring version, workpiece dimensions can be measured at front edges and from these offsets are derived.

The measurement result and the measurement difference can be used as follows:

- Correction of a work offset
- Offset of a tool
- Measurement without offset

Note

Extended measurement

Information on measurement in conjunction with a third axis can be found in Chapter Extended measurement (Page 81).

Measuring principle

The measuring cycle determines the actual value of a measuring point at a front edge of the turned part, relative to the workpiece zero.

The difference between the actual value (measured value) and a specified setpoint in the 1st axis of the plane is calculated (for G18: Z).

An extended tool offset in the summed and setup offsets is possible.

For the tool offset, generally empirical values can be included in the calculation.

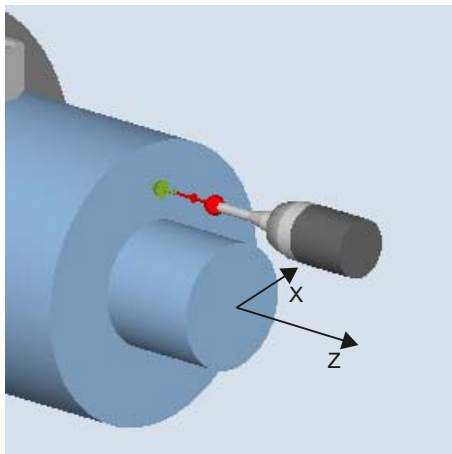

Figure 2-3 Measure: front edge (CYCLE974)

Preconditions

- The probe must be calibrated in the measuring direction and active as tool. The probe type is 580.
- The cutting edge position can be 5 to 8 and must be suitable for the measurement task.
- If necessary, the workpiece must be positioned in the correct angular spindle position using spindle positioning (SPOS).

Starting position before the measurement

The probe must be positioned opposite the surface to be measured and is reached by traversing the measuring axis in the setpoint direction in the measuring cycle.

Position after the end of the measuring cycle

When the measuring process has been completed, the probe is positioned at the distance of the measurement path (DFA) from the measuring surface.

Procedure

The part program or ShopTurn program to be processed has been created and you are in the editor.



1. Press the "Meas. workpiece" softkey.





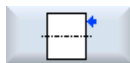





2. Press the "Turning measurement" softkey.



3. Press the "Set front edge" softkey.
The input window "Measure: front edge" is opened.

Parameters

G code program			ShopTurn program		
Parameters	Description	Unit	Parameters	Description	Unit
	Calibration data set (1 - 12)	-	T	Name of the probe	-
			D 	Cutting edge number (1 - 9)	-
				Calibration data set (1 - 12)	-
			β 	Tool alignment with swivel axis <ul style="list-style-type: none"> •  (0 degrees) •  (90 degrees) • Value entry 	Degrees
			Z	Start point Z of the measurement	mm
			X	Start point X of the measurement	mm
			Y	Start point Y of the measurement	mm

Parameters	Description	Unit
Correction target 	<ul style="list-style-type: none"> • Measuring only (no offset) • Work offset (save measured values in an adjustable WO) ¹⁾ • Tool offset (save measured value in the tool data) 	-
TR	Name of tool to be corrected	-
D 	Cutting edge number of tool to be corrected	-
Z0	Reference point Z	mm
DFA	Measurement path	mm
TSA	Safe area for the measurement result	mm
Dimensional tolerance 	Use dimensional tolerance (only for the "Tool offset" correction target) <ul style="list-style-type: none"> • Yes • No 	-
TUL	Upper tolerance limit, workpiece (only for dimensional tolerance"Yes")	mm
TLL	Lower tolerance limit, workpiece (only for dimensional tolerance"Yes")	mm

¹⁾ Other parameters and correction targets can be set in the general SD 54760 \$SNS_MEA_FUNCTION_MASK_PIECE .



Machine manufacturer

Please observe the machine manufacturer's instructions.

List of the result parameters

The measuring variant "Front edge" provides the following result parameters:

Table 2- 6 "Front edge" result parameters

Parameters	Description	Unit
_OVR [0]	Setpoint value for measuring axis	mm
_OVR [1]	Setpoint in 1st axis of the plane → only for S_MA=1	mm
_OVR [2]	Setpoint in 2nd axis of the plane → only for S_MA=2	mm
_OVR [3]	Setpoint in 3rd axis of the plane → only for S_MA=3	mm
_OVR [4]	Actual value for measuring axis	mm
_OVR [5]	Actual value in 1st axis of the plane → only for S_MA=1	mm
_OVR [6]	Actual value in 2nd axis of the plane → only for S_MA=2	mm
_OVR [7]	Actual value in 3rd axis of the plane → only for S_MA=3	mm
_OVR [16]	Difference for measuring axis	mm
_OVR [17]	Difference in 1st axis of the plane → only for S_MA=1	mm
_OVR [18]	Difference in 2nd axis of the plane → only for S_MA=2	mm
_OVR [19]	Difference in 3rd axis of the plane → only for S_MA=3	mm
_OVI [0]	D number or WO number	-
_OVI [2]	Measuring cycle number	-

For workpiece measurement with tool offset or correction in the work offset, additional parameters are displayed, see Additional result parameters (Page 265).

2.2.6 Turning measurement - inside diameter (CYCLE974, CYCLE994)

Function

With this measuring version, the inside diameter of cylindrical workpieces can be measured. Diameter and radius programming are supported.

The measurement result (measurement difference) can be used as follows:

- Correction in the work offset (only for 1-point measurements)
- Offset of a tool
- Measurement without offset

Note

Extended measurement

Information on measurement in conjunction with a third axis can be found in ChapterExtended measurement (Page 81).

Measuring principle

The measuring cycle determines the actual value of an inner diameter using a 1-point measurement or 2-point measurement symmetrically around the workpiece zero (center of rotation). The 2-point measurement is performed by reversing the spindle through 180 degree of the workpiece or by making measurements above and below the center of rotation.

An extended tool offset in the summed and setup offsets is possible.

For the tool offset, generally empirical values can be included in the calculation.

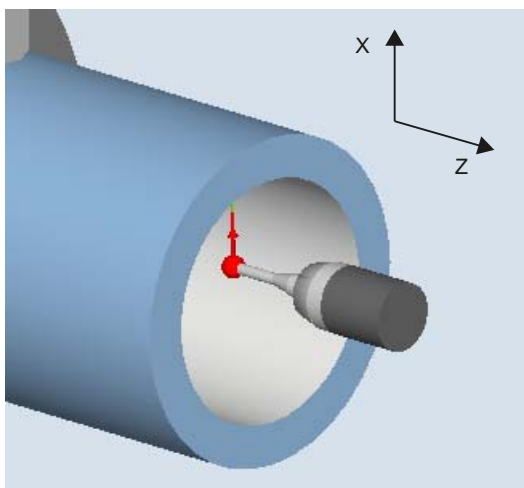

Figure 2-4 Measure: Inside diameter (CYCLE974)

Positioning "Travel below the center" (CYCLE994)

For "Travel below the center", the inside diameter of the workpiece is measured using a 2-point measurement with the measuring cycle CYCLE994 . Two opposite measuring points symmetrical to the workpiece zero (center of rotation) are approached at a distance of the setpoint specified by the user.

A protection zone can be programmed, which should be taken into account when traversing. The user must take into account the ball radius of the probe when dimensioning the protection zone.

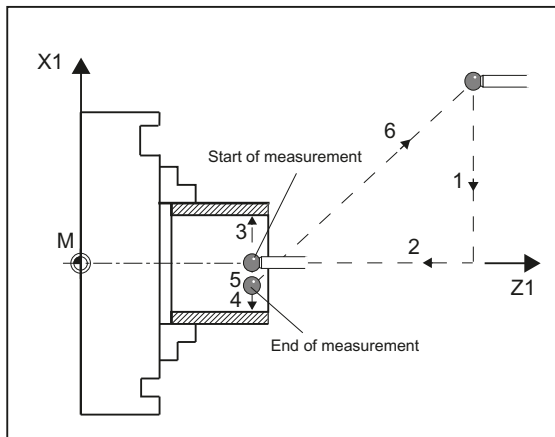

Figure 2-5 Positions of the probe when measuring the inner diameter using 2-point measurement (CYCLE994)

Measuring with reversal of the workpiece (CYCLE974)

With this measuring version, the actual value of a workpiece with reference to the workpiece zero in the measuring axis, is determined by acquiring two opposite points on the diameter.

The workpiece is positioned by the cycle before the first measurement at the angular position programmed in parameter $\alpha 0$. After the 1st measurement, the cycle also automatically generates the 180 degree reversal before the second measurement. The mean value is calculated from both measured values.

A correction of the work offset (WO) is only possible when measuring without reversal (1-point measurement).

Preconditions

- The probe must be calibrated in the measuring direction.
- The probe type is 580 and must be active.
- The cutting edge position can be 5 to 8 and must be suitable for the measurement task.

Starting position before the measurement

The probe should be positioned opposite the surface to be measured, above the turning center.

Position after the end of the measuring cycle

The probe is at a distance of the measuring path (DFA) from the measuring surface, above the turning center.

When "Travel under the center of rotation" is selected, after the end of the measuring cycle, the probe is at a distance of the measuring path (DFA) from the measuring surface, below the center of rotation.

Procedure

The part program or ShopTurn program to be processed has been created and you are in the editor.



1. Press the "Meas. workpiece" softkey.



2. Press the "Turning measurement" softkey.



3. Press the "Inside diameter" softkey.

The input window "Measure: inside diameter" is opened.

Parameters

G code program			ShopTurn program		
Parameter	Description	Unit	Parameter	Description	Unit
	Calibration data record (1 - 12)	-	T	Name of the probe	-
			D	Cutting edge number (1 - 9)	-
				Calibration data record (1 - 12)	-
			β	Tool alignment with swivel axis <ul style="list-style-type: none"> • ← (0 degrees) • ↓ (90 degrees) • Value entry 	Degrees
			Z	Start point Z of the measurement	mm
			X	Start point X of the measurement	mm

2.2 Measure workpiece (turning)

Parameter	Description	Unit
Correction target U	<ul style="list-style-type: none"> Measuring only (no offset) Zero offset (save measured value in an adjustable ZO) ^{1) 2)} Tool offset (save measured value in the tool data) 	-
TR	Name of tool to be corrected	-
D U	Cutting edge number of tool to be corrected	-
Ø	Inner diameter	mm
Positioning U	<ul style="list-style-type: none"> Measuring without reversal of the workpiece Measuring with reversal of the workpiece (180°) ³⁾ Travel below center (measuring above and below the center of rotation) 	-
α0	Starting angle for spindle reversal (only for positioning "with reversal")	Degrees
Protection zone U	Use protection zone (only for positioning "Travel below center") <ul style="list-style-type: none"> Yes No 	-
ØS	Diameter of the protection zone (only for protection zone "Yes")	mm
DZ (for G18)	Infeed distance at measuring height (only for protection zone "Yes")	mm
DFA	Measurement path	mm
TSA	Safe area for the measurement result	mm
Dimensional tolerance U	Use dimensional tolerance (only for the "Tool offset" correction target) <ul style="list-style-type: none"> Yes No 	-
TUL	Upper tolerance limit, workpiece (only for dimensional tolerance "Yes")	mm
TLL	Lower tolerance limit, workpiece (only for dimensional tolerance "Yes")	mm

- 1) Only for positioning "without reversal"
- 2) Other parameters and correction targets can be set in the general SD 54760 \$SNS_MEA_FUNCTION_MASK_PIECE .
- 3) The "Measurement with reversal of the workpiece" function is displayed if bit 0 is set in the general SD 54764 \$SNS_MEA_FUNCTION_MASK_TURN.



Machine manufacturer

Please observe the machine manufacturer's instructions.

List of the result parameters

The measuring variant "Inside diameter" provides the following result parameters:

Table 2- 7 "Inside diameter" result parameters

Parameters	Description	Unit
_OVR [0]	Diameter setpoint (note measuring axis S_MA)	mm
_OVR [1]	Diameter setpoint in 1st axis of the plane → only for S_MA=1	mm
_OVR [2]	Diameter setpoint in 2nd axis of the plane → only for S_MA=2	mm
_OVR [3]	Diameter setpoint in 3rd axis of the plane → only for S_MA=3	mm
_OVR [4]	Diameter actual value	mm
_OVR [5]	Diameter actual value in 1st axis of the plane → only for S_MA=1	mm
_OVR [6]	Diameter actual value in 2nd axis of the plane → only for S_MA=2	mm
_OVR [7]	Diameter actual value in 3rd axis of the plane → only for S_MA=3	mm
_OVR [16]	Diameter difference	mm
_OVR [17]	Diameter difference in 1st axis of the plane → only for S_MA=1	mm
_OVR [18]	Diameter difference in 2nd axis of the plane → only for S_MA=2	mm
_OVR [19]	Diameter difference in 3rd axis of the plane → only for S_MA=3	mm
_OVI [0]	D number	-
_OVI [2]	Measuring cycle number	-

For workpiece measurement with tool offset or correction in the work offset, additional parameters are displayed, see Additional result parameters (Page 265).

2.2.7 Turning measurement - outside diameter (CYCLE974, CYCLE994)

Function

With this measuring version, the outer diameter of cylindrical workpieces can be measured. Diameter and radius programming are supported.

The measurement result (measurement difference) can be used as follows:

- Correction in the work offset (only for measuring without reversal, 1-point measurement)
- Offset of a tool
- Measurement without offset

Note

Extended measurement

Information on measurement in conjunction with a third axis can be found in Chapter Extended measurement (Page 81).

Measuring principle

The measuring cycle determines the actual value of an inner diameter using a 1-point measurement or 2-point measurement symmetrically around the workpiece zero (center of rotation). The 2-point measurement is performed by reversing the spindle through 180 degree of the workpiece or by making measurements above and below the center of rotation.

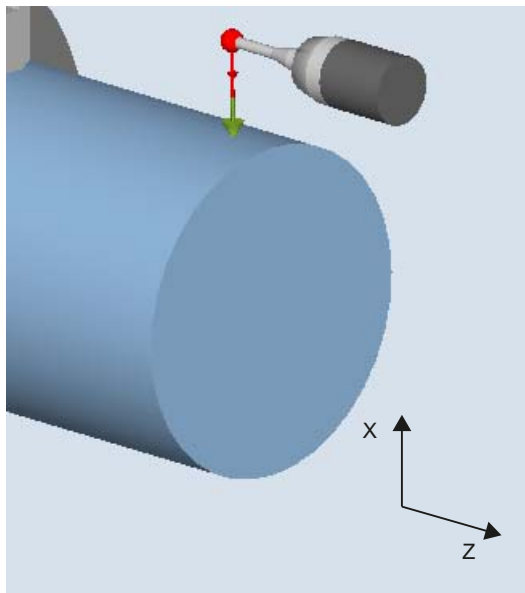

Measure: Outside diameter (CYCLE974) with/without reversal of the workpiece

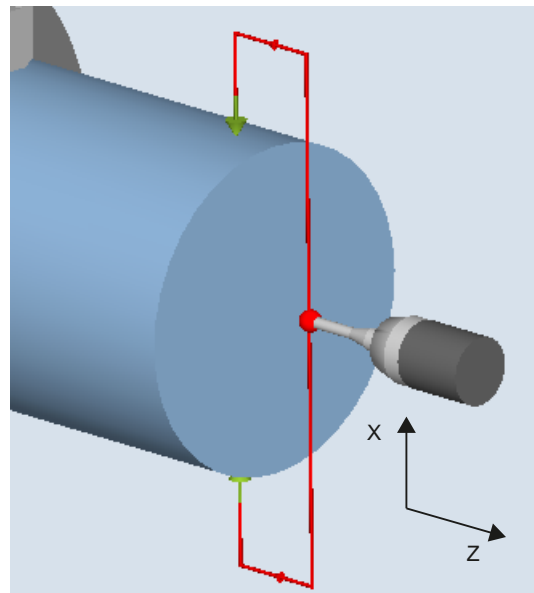

Measure: Outside diameter (CYCLE994) above and below the turning center

Positioning "Travel below the center" (CYCLE994)

For "Travel below the center", the outer diameter of the workpiece is measured using a 2-point measurement with the measuring cycle CYCLE994. Two opposite measuring points symmetrical to the workpiece zero (center of rotation) are approached at a distance of the setpoint specified by the user. When traversing, a safety zone is taken into account. The user must take into account the ball radius of the probe when dimensioning the protection zone.

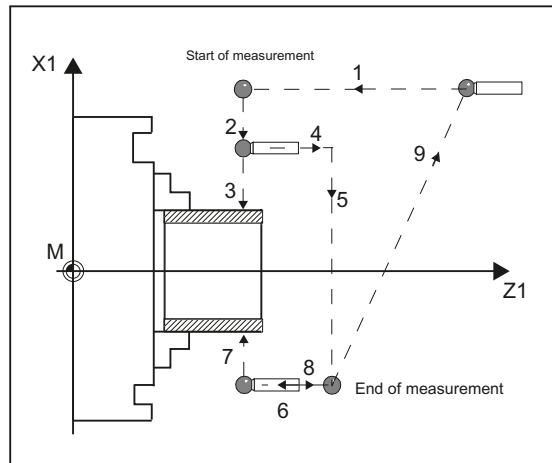

Figure 2-6 Positions of the probe when measuring the outer diameter (CYCLE994) taking account a protection zone

Measuring with reversal of the workpiece (CYCLE974)

With this measuring version, the actual value of a workpiece with reference to the workpiece zero in the measuring axis, is determined by acquiring two opposite points on the diameter.

The workpiece is positioned by the cycle before the first measurement at the angular position programmed in parameter $\alpha 0$. After the 1st measurement, the cycle also automatically generates the 180 degree reversal before the second measurement. The mean value is calculated from both measured values.

A correction of the work offset (WO) is only possible when measuring without reversal (1-point measurement).

Preconditions

- The probe must be calibrated in the measuring directions.
- In the measuring version "travel below the center of rotation", measurements can also be performed without previous calibration if bit2 is set to 1 in the channel-specific MD 52740 \$MCS_MEA_FUNCTION_MASK.
- The probe type is 580 and must be active.
- The cutting edge position can be 5 to 8 and must be suitable for the measurement task.

Starting position before the measurement

The probe should be positioned opposite the surface to be measured, above the turning center.

Position after the end of the measuring cycle

The probe is at a distance of the measuring path (DFA) from the measuring surface, above the turning center.

If "Travel under the center of rotation" was selected, after the end of the measuring cycle, the probe is at a distance of the measuring path (DFA) from the measuring surface, below the center of rotation.

Procedure

The part program or ShopTurn program to be processed has been created and you are in the editor.



1. Press the "Meas. workpiece" softkey.



2. Press the "Turning measurement" softkey.

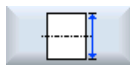

3. Press the "Outside diameter" softkey.

The input window "Measure: outer diameter" is opened.

Parameters

G code program			ShopTurn program		
Parameter	Description	Unit	Parameter	Description	Unit
	Calibration data record (1 - 12)	-	T	Name of the probe	-
			D	Cutting edge number (1 - 9)	-
				Calibration data record (1 - 12)	-
			β	Tool alignment with swivel axis <ul style="list-style-type: none"> • ← (0 degrees) • ↓ (90 degrees) • Value entry 	Degrees
			Z	Start point Z of the measurement	mm
			X	Start point X of the measurement	mm

Parameter	Description	Unit
Correction target U	<ul style="list-style-type: none"> Measuring only (no offset) Zero offset (save measured value in an adjustable ZO) ^{1) 2)} Tool offset (save measured value in the tool data) 	-
TR	Name of tool to be corrected	-
D U	Cutting edge number of tool to be corrected	-
∅	Outer diameter	mm
Positioning U	<ul style="list-style-type: none"> Measuring without reversal of the workpiece Measuring with reversal of the workpiece ³⁾ Travel below center (measuring above and below the center of rotation) 	-
α0	Starting angle for spindle reversal (only for positioning "Measuring with reversal")	Degrees
DZ (for G18)	Infeed distance at measuring height (only for positioning "Travel below center")	mm
Protection zone U	Use protection zone (only for positioning "Travel below center") <ul style="list-style-type: none"> Yes No 	-
∅ S	Diameter of the protection zone (only for Use protection zone "Yes")	mm
DFA	Measurement path	mm
TSA	Safe area for the measurement result	mm
Dimensional tolerance U	Use dimensional tolerance (only for the "Tool offset" correction target) <ul style="list-style-type: none"> Yes No 	-
TUL	Upper tolerance limit, workpiece (only for dimensional tolerance "Yes")	mm
TLL	Lower tolerance limit, workpiece (only for dimensional tolerance "Yes")	mm

1) Only for positioning "Measuring without reversal"

2) Other parameters and correction targets can be set in the general SD 54760 \$SNS_MEA_FUNCTION_MASK_PIECE.

3) The "Measurement with reversal of the workpiece" function is displayed if bit 0 is set in the general SD 54764 \$SNS_MEA_FUNCTION_MASK_TURN.



Machine manufacturer

Please observe the machine manufacturer's instructions.

List of the result parameters

The measuring variant "Outside diameter" provides the following result parameters:

Table 2- 8 "Outside diameter" result parameters

Parameters	Description	Unit
_OVR [0]	Diameter setpoint (note measuring axis S_MA)	mm
_OVR [1]	Diameter setpoint in 1st axis of the plane → only for S_MA=1	mm
_OVR [2]	Diameter setpoint in 2nd axis of the plane → only for S_MA=2	mm
_OVR [3]	Diameter setpoint in 3rd axis of the plane → only for S_MA=3	mm
_OVR [4]	Diameter actual value	mm
_OVR [5]	Diameter actual value in 1st axis of the plane → only for S_MA=1	mm
_OVR [6]	Diameter actual value in 2nd axis of the plane → only for S_MA=2	mm
_OVR [7]	Diameter actual value in 3rd axis of the plane → only for S_MA=3	mm
_OVR [16]	Diameter difference	mm
_OVR [17]	Diameter difference in 1st axis of the plane → only for S_MA=1	mm
_OVR [18]	Diameter difference in 2nd axis of the plane → only for S_MA=2	mm
_OVR [19]	Diameter difference in 3rd axis of the plane → only for S_MA=3	mm
_OVI [0]	D number	-
_OVI [2]	Measuring cycle number	-

For workpiece measurement with tool offset or correction in the work offset, additional parameters are displayed, see Additional result parameters (Page 265).

2.2.8 Extended measurement

Measuring in conjunction with a 3rd axis (Y)

If a lathe has a 3rd axis, for technological reasons it can make sense to also use this as a measuring axis. In this case, pre-positioning and the measuring operation are realized in the 3rd axis (Y axis); however, the measuring result correction is entered in the tool and WO components of the 2nd geometry axis (X axis). The 3rd axis supports the radius and diameter programming according to the relationships of the 2nd geometry axis (X).

Note

The function of including the 3rd axis for lathes refers to the measuring cycles CYCLE974 and CYCLE994! This function must be enabled, see

References: Commissioning Manual *SINUMERIK Operate (IM9) / SINUMERIK 840D sl*, Chapter "Measuring workpieces when turning".

Extended bypass options for 2-point measurement (CYCLE994)

If a lathe has a 3rd axis, then it can also be optionally used as a bypass axis.

The bypass strategies discussed in the following can be realized using the parameter assignment screen forms or the number of the measuring axis (Parameter S_MA).

Basis for the extended bypass strategy is that the 3rd axis has been enabled for measuring cycles.

S_MA, multi-digit = 102

1. Axis of the plane is the bypass axis (Z)

2nd axis of the plane, is the measuring axis (X)

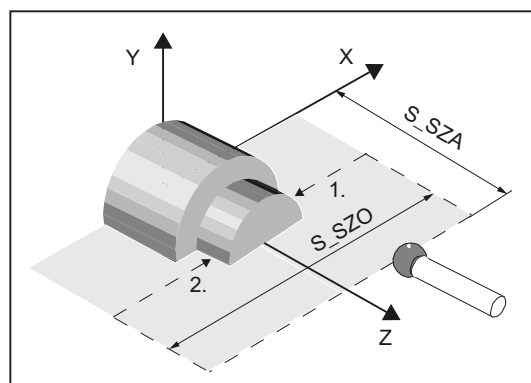

Probe with cutting edge position (SL)=7

S_MA, multi-digit = 103

1. Axis of the plane is the bypass axis (Z)

3rd axis is the measuring axis (Y)

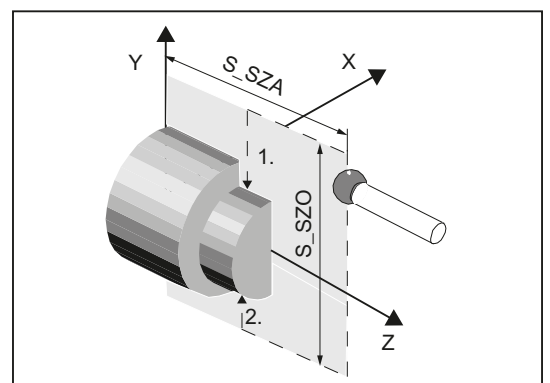

Probe with SL=7

S_MA, multi-digit = 302

3. Axis is the bypass axis (Y)
 2nd axis of the plane, is the measuring axis (X)

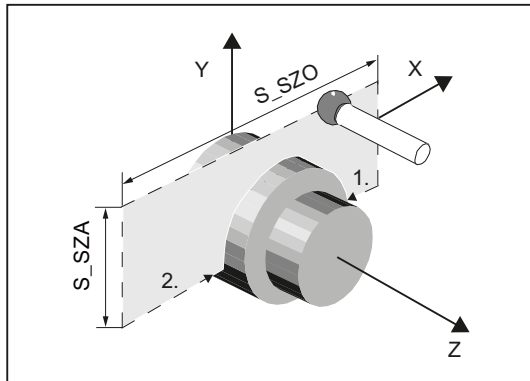

Probe with SL=7

S_MA, multi-digit = 203

2. Axis of the plane is the bypass axis (X)
 3rd axis is the measuring axis (Y)

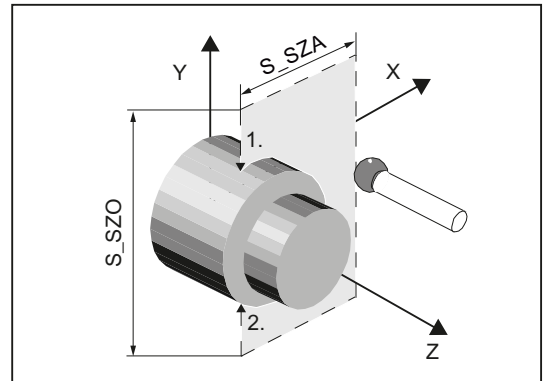

Probe with SL=7

S_MA, multi-digit = 301

3. Axis is the bypass axis (Y)
 1st axis of the plane, is the measuring axis (Z)

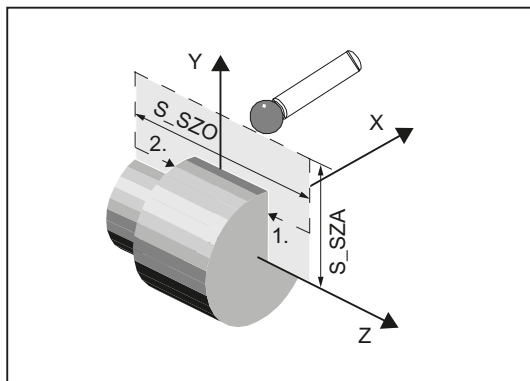

Probe with SL=8

2.3 Measure workpiece (milling)

2.3.1 Calibrate probe - length (CYCLE976)

Function

Using this measuring version, the length of a workpiece probe can be calibrated in the tool axis on a known surface (reference area). This can be done, for example, on a workpiece.

Measuring principle

The probe travels in the measuring direction on the edge (e.g. workpiece)

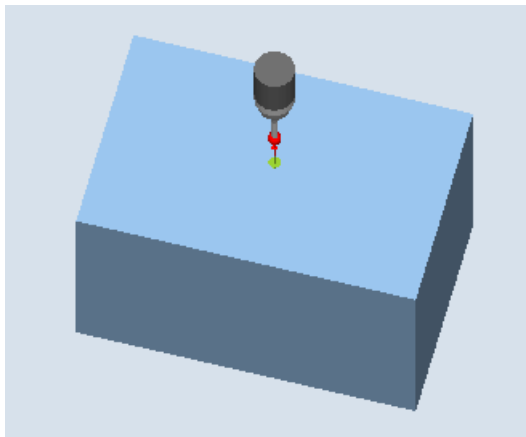

Figure 2-7 Calibrate: Length at edge (CYCLE976)

The length of the probe is determined corresponding to the setting in general MD 51740 `$MNS_MEA_FUNCTION_MASK`, bit 1. The setting determines whether the tool length refers to the probe ball center or the probe ball circumference.

In the version tool length to ball center, a trigger value is entered into the calibration data according to the calibration direction.

References: Commissioning Manual *SINUMERIK Operate (IM9) / SINUMERIK 840D sl*, Chapter "Measuring cycles and measurement functions".

Requirements

- The probe must be active as tool.
- Probe type:
 - 3D multi probe (type 710)
 - Mono probe (type 712)
 - L probe (type 713)

Note

L probe application (type 713)

Measurement is possible in +Z (towing measurement) or toward +X with the L probe.

The standard alignment of the L probe is toward +X (offset angle = 0). If the L probe is to be aligned in a different direction in the measuring program, this can be performed through a rotation around the tool axis (e.g. ROT Z = 90).

- The approximate probe length must be known in the program for collision-free positioning of the workpiece probe and entered in the tool offset memory.
- The ball radius must be known exactly and entered in the tool data. For example, this can be implemented using a previous calibration in the ring or on the ball.
- The calibration surface is perpendicular to measuring axis or tool axis.

Starting position before the measurement

The probe must be positioned opposite to the calibration surface.

The distance between the probe and calibration surface should be approximately the same as the selected measurement path (DFA).

Position after the end of the measuring cycle

According to the measuring direction (X, Y, Z), the distance between the probe and the calibration surface is the same as the distance of the selected measurement path (DFA).

Procedure

The part program or ShopMill program to be processed has been created and you are in the editor.



1. Press the "Meas. workpiece" softkey.











2. Press the "Calibrate probe" softkey.



3. Press the "Length" softkey.
The input window "Calibrate: Length at edge" is opened.

Parameters

G code program			ShopMill program		
Parameters	Description	Unit	Parameters	Description	Unit
PL 	Measuring plane (G17 - G19)	-	T	Name of the probe	-
 	Calibration data set (1 - 12)	-	D 	Cutting edge number (1 - 9)	-
F	Calibration and measuring feedrate	Distance/ min	 	Calibration data set (1 - 12)	-
			F	Calibration and measuring feedrate	mm/min
			X	Start point X of the measurement	mm
			Y	Start point Y of the measurement	mm
			Z	Start point Z of the measurement	mm

Parameters	Description	Unit
Adapt tool length 	<ul style="list-style-type: none"> Yes (adapt probe length and trigger point) No (adapt trigger point only) 	-
Measuring direction 	Measuring axis (+/-) Z (for measuring plane G17)	-
Z0	Reference point Z (for measuring plane G17)	mm
DFA	Measurement path	mm
TSA	Safe area for the measurement result	mm

NOTICE

When the calibration is performed for the first time, the default setting in the data field of the probe is still "0". For this reason, the **TSA** parameter must be programmed > probe ball radius to avoid the alarm "Safe area exceeded".

List of the result parameters

The measuring version "Length" provides the following result parameters:

Table 2- 9 "Length" result parameters

Parameters	Description	Unit
_OVR [4]	Actual value probe ball diameter	mm
_OVR [5]	Difference probe ball diameter	mm
_OVR [16]	Trigger point in minus direction, actual value of 3rd axis of the plane	mm
_OVR [17]	Trigger point in minus direction, difference of 3rd axis of the plane	mm
_OVR [18]	Trigger point in plus direction, actual value of 3rd axis of the plane	mm
_OVR [19]	Trigger point in plus direction, difference of 3rd axis of the plane	mm
_OVR [22]	Probe length of the workpiece probe	mm
_OVR [27]	Work offset range	mm
_OVR [28]	Safe area	mm
_OVI [2]	Measuring cycle number	-
_OVI [5]	Probe number	-
_OVI [9]	Alarm number	-

2.3.2 Calibrate probe - radius in ring (CYCLE976)

Function

With this measuring version, the skew of the workpiece probe as well as the trigger values and the radius of the probe ball can be calibrated in a calibration ring (in the axes of the plane).

The probe calibration in the ring, can be on the basis of an unknown or known center point in the ring. With known center point, this corresponds to the starting point.

Calibration is also possible taking into account a starting angle when using the "start at ring center" calibration version. Any obstacles in the measuring path or at the measuring point can be avoided when using a starting angle.

Measuring principle

Calibration always starts in the positive direction of the 1st axis of the actual machining plane. Eight calibration positions are to be acquired, divided into two passes. Depending on the probe type, the passes are made with a uniform spindle position or a reversal of 180 degrees.

During the calibration process, the center point of the calibration ring (corresponding to the calibration version) and its distance to the start position are determined.

The calibration data / trigger values are significantly influenced in the result by the following variables:

- Physical probe ball radius
- Design of the probe
- Measuring velocity
- Calibration ring with corresponding accuracy
- Correct mounting of the calibrating ring

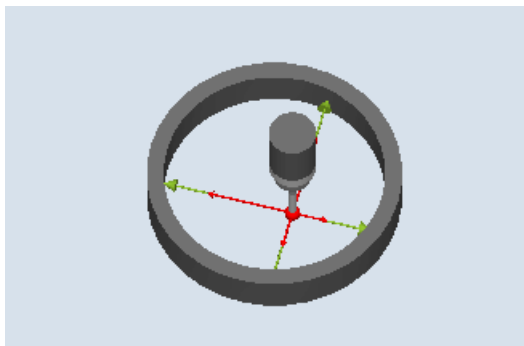

Figure 2-8 Calibrate: Radius in ring (CYCLE976)

Requirements

The following requirements must be fulfilled for calibration in the ring:

- The probe must be active as tool.
- Probe type:
 - 3D multi probe (type 710)
 - Mono probe (type 712)
 - L probe (type 713)

Note

L probe application (type 713)

Measurement is possible in +Z (towing measurement) or toward +X with the L probe.

The standard alignment of the L probe is toward +X (offset angle = 0). If the L probe is to be aligned in a different direction in the measuring program, this can be performed through a rotation around the tool axis (e.g. ROT Z = 90).

- Star-type probe (type 714)
- The exact diameter of the calibration ring is known.

Starting position before the measurement

When the measuring cycle is not started at the center of the ring, the workpiece probe ball center must be positioned close to the center of the ring as well as to a calibration height within the calibration ring.

When starting the measuring cycle at the center of the ring, the workpiece probe ball center must be positioned precisely at the ring center point as well as at a calibration height within the calibration ring.

Position after the end of the measuring cycle

When calibration is complete, the probe center is at calibration height in the center of the ring.

Note

For extremely high demands placed on the measuring accuracy, it makes sense to accept the distance between the center point and starting position in the zero offset and to perform an additional calibration using this optimization.

Procedure

The part program or ShopMill program to be processed has been created and you are in the editor.



1. Press the "Meas. workpiece" softkey.



2. Press the "Calibrate probe" softkey.



3. Press the "Radius in ring" softkey.

The input window "Calibrate: Radius in ring" is opened.

Parameters

G code program			ShopMill program		
Parameters	Description	Unit	Parameters	Description	Unit
PL	Measuring plane (G17 - G19)	-	T	Name of the probe	-
	Calibration data set (1 - 12)	-	D	Cutting edge number (1 - 9)	-
F	Calibration and measuring feedrate	Distance/min		Calibration data set (1 - 12)	-
			F	Calibration and measuring feedrate	mm/min
			X	Start point X of the measurement	mm
			Y	Start point Y of the measurement	mm
			Z	Start point Z of the measurement	mm

Parameters	Description	Unit
∅	Ring diameter	mm
DFA	Measurement path	mm
TSA	Safe area for the measurement result	mm

NOTICE

When the calibration is performed for the first time, the default setting in the data field of the probe is still "0". For this reason, the **TSA** parameter must be programmed > probe ball radius to avoid the alarm "Safe area exceeded".

List of the result parameters

The measuring variant "Radius in Ring" provides the following result parameters:

Table 2- 10 "Radius in ring" result parameters

Parameters	Description	Unit
_OVR [4]	Actual value probe ball diameter	mm
_OVR [5]	Difference probe ball diameter	mm
_OVR [6]	Center point of calibration ring in 1st axis of the plane	mm
_OVR [7]	Center point of calibration ring in 2nd axis of the plane	mm
_OVR [8]	Trigger point in minus direction, actual value of 1st axis of the plane	mm
_OVR [9]	Trigger point in minus direction, difference of 1st axis of the plane	mm
_OVR [10]	Trigger point in plus direction, actual value of 1st axis of the plane	mm
_OVR [11]	Trigger point in plus direction, difference of 1st axis of the plane	mm
_OVR [12]	Trigger point in minus direction, actual value of 2nd axis of the plane	mm
_OVR [13]	Trigger point in minus direction, difference of 2nd axis of the plane	mm
_OVR [14]	Trigger point in plus direction, actual value of 2nd axis of the plane	mm
_OVR [15]	Trigger point in plus direction, difference of 2nd axis of the plane	mm
_OVR [20]	Positional deviation of the 1st axis of the plane (probe skew)	mm
_OVR [21]	Positional deviation of the 2nd axis of the plane (probe skew)	mm
_OVR [24]	Angle at which the trigger points were determined	Degrees
_OVR [27]	Zero offset area	mm
_OVR [28]	Safe area	mm
_OVI [2]	Measuring cycle number	-
_OVI [5]	Probe number	-
_OVI [9]	Alarm number	-

2.3.3 Calibrate probe - radius on edge (CYCLE976)

Function

With this measuring version, a workpiece probe can be calibrated in an axis and direction selected by the user, at a reference surface perpendicular to this. This can be done, for example, on a workpiece.

If two calibration directions are selected for an axis (calibrating in the groove), then for this axis, the positional deviation can be calculated (probe skew).

Measuring principle

The probe approaches the reference surface in the selected axis and direction. If the two calibration directions version was selected, initially, the axis moves in the positive axis direction.

The determined parameters, trigger point, positional deviation and probe ball radius are transferred into the addressed calibration data fields.

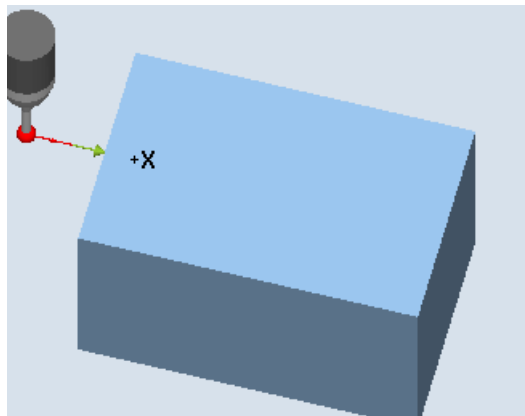

Calibrate: Radius at edge (CYCLE976), one calibration direction

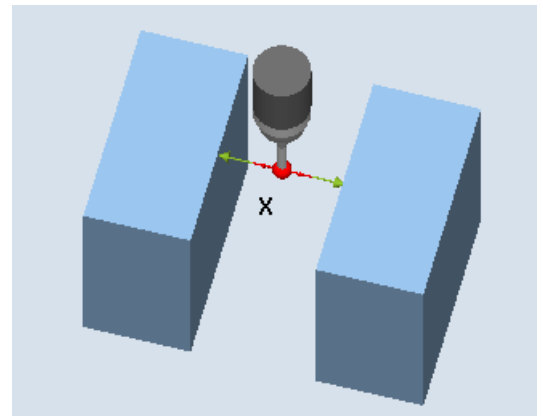

Calibrate: Radius at edge (CYCLE976), two calibration directions

Requirements

- The probe must be active as tool.
- Tool type of the probe:
 - 3D multi probe (type 710)
 - Mono probe (type 712)

Starting position before the measurement

The probe is positioned in the measuring height, approximately at the distance of the measurement path (DFA) opposite to the edge.

Position after the end of the measuring cycle

The probe ball center is located in front of the reference edge by the distance of the measuring path.

Procedure

The part program or ShopMill program to be processed has been created and you are in the editor.



1. Press the "Meas. workpiece" softkey.



2. Press the "Calibrate probe" softkey.



3. Press the "Radius at edge" softkey.
The input window "Calibrate: Radius at edge" is opened.

Parameters

G code program			ShopMill program		
Parameters	Description	Unit	Parameters	Description	Unit
PL	Measuring plane (G17 - G19)	-	T	Name of the probe	-
	Calibration data set (1 - 12)	-	D	Cutting edge number (1 - 9)	-
F	Calibration and measuring feedrate	Distance/min		Calibration data set (1 - 12)	-
			F	Calibration and measuring feedrate	mm/min
			X	Start point X of the measurement	mm
			Y	Start point Y of the measurement	mm
			Z	Start point Z of the measurement	mm

Parameters	Description	Unit
Calibration directions	<ul style="list-style-type: none"> 1: Calibration in one direction 2: Calibrations in opposite directions 	-
Measuring direction	Measuring axis (for G17): <ul style="list-style-type: none"> (+/-) X (+/-) Y 	-
DX /DY	Distance between the edges (only for calibration directions "2")	mm
X0 / Y0	Reference point X/Y (only for calibration directions "1"; corresponding to the measuring direction)	mm
DFA	Measurement path	mm
TSA	Safe area for the measurement result	mm

NOTICE

When the calibration is performed for the first time, the default setting in the data field of the probe is still "0". For this reason, the **TSA** parameter must be programmed > probe ball radius to avoid the alarm "Safe area exceeded".

List of the result parameters

The measuring variant "Radius on edge" provides the following result parameters:

Table 2- 11 "Radius on edge" result parameters

Parameters	Description	Unit
_OVR [4]	Actual value probe ball diameter	mm
_OVR [5]	Difference probe ball diameter	mm
_OVR [8]	Trigger point in minus direction, actual value of 1st axis of the plane	mm
_OVR [10]	Trigger point in plus direction, actual value of 1st axis of the plane	mm
_OVR [12]	Trigger point in minus direction, actual value of 2nd axis of the plane	mm
_OVR [14]	Trigger point in plus direction, actual value of 2nd axis of the plane	mm
_OVR [9]	Trigger point in minus direction, difference of 1st axis of the plane	mm
_OVR [11]	Trigger point in plus direction, difference of 1st axis of the plane	mm
_OVR [13]	Trigger point in minus direction, difference of 2nd axis of the plane	mm
_OVR [15]	Trigger point in plus direction, difference of 2nd axis of the plane	mm
_OVR [20]	Positional deviation of the 1st axis of the plane (probe skew)	mm
_OVR [21]	Positional deviation of the 2nd axis of the plane (probe skew)	mm
_OVR [24]	Angle at which the trigger points were determined	Degrees
_OVR [27]	Zero offset area	mm
_OVR [28]	Safe area	mm
_OVI [2]	Measuring cycle number	-
_OVI [5]	Probe number	-
_OVI [9]	Alarm number	-

2.3.4 Calibrate probe - calibrate on ball (CYCLE976)

Function

Using this measuring version, a workpiece probe can be calibrated at any position in space. This has a special meaning in conjunction with swivel functions and transformations.

The same calibration data are generated as for calibration in the ring: the skew of the workpiece probe, the trigger values and the radius of the probe ball. In addition, the probe length in the tool axis can be determined. This can be performed with reference to the probe ball end or ball circumference.

The calibration ball center is determined as supplementary result.

Measuring principle

The measurement sequence is divided into the following steps:

1. Determining the center point coordinates of the reference sphere
2. Determining the calibration data

This procedure can be made parallel to the axis by passing or moving around the reference sphere.

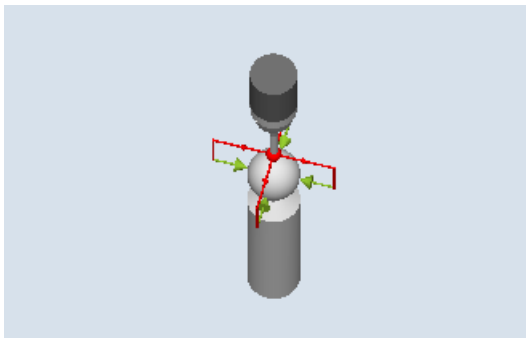

Figure 2-9 Calibration at the ball (CYCLE976), example, passing (intermediate positioning parallel to the axis)

Requirements

- The diameter of the reference ball must be known.
- Tool type of the probe:
 - 3D multi probe (type 710)
 - Mono probe (type 712)
 - Star-type probe (type 714)

Starting position before the measurement

The workpiece probe must be positioned above the reference sphere so that it can be approached collision-free from above and at the circumference.

Position after the end of the measuring cycle

The workpiece probe is located above the ball center.

Procedure

The part program or ShopMill program to be processed has been created and you are in the editor.



1. Press the "Meas. workpiece" softkey.



2. Press the "Calibrate probe" softkey.



3. Press the "Calibrate on ball" softkey.
The input window "Calibrate: Probe on ball" is opened.

Parameters

G code program			ShopMill program		
Parameters	Description	Unit	Parameters	Description	Unit
PL	Measuring plane (G17 - G19)	-	T	Name of the probe	-
	Calibration data set (1 - 12)	-	D	Cutting edge number (1 - 9)	-
F	Calibration and measuring feedrate	Distance/ min		Calibration data set (1 - 12)	-
			F	Calibration and measuring feedrate	mm/min
			X	Start point X of the measurement	mm
			Y	Start point Y of the measurement	mm
			Z	Start point Z of the measurement	mm

Parameters	Description	Unit
Positioning	Moving around the ball <ul style="list-style-type: none"> Parallel to the axis Moving around on a circular path 	-
Adapt tool length	<ul style="list-style-type: none"> Yes (adapt probe length and trigger point) No (adapt trigger point only) 	-
ZS (for G17)	Upper edge of the calibration ball (only for adapt tool length "Yes")	mm
∅	Sphere diameter	mm
α0	Contact angle	Degrees
DFA	Measurement path	mm
TSA	Safe area for the measurement result	mm

List of the result parameters

The measuring variant "Radius on sphere" provides the following result parameters:

Table 2- 12 "Radius on sphere" result parameters

Parameters	Description	Unit
_OVR [4]	Actual value probe ball diameter	mm
_OVR [5]	Difference probe ball diameter	mm
_OVR [8]	Trigger point in minus direction, actual value of 1st axis of the plane	mm
_OVR [10]	Trigger point in plus direction, actual value of 1st axis of the plane	mm
_OVR [12]	Trigger point in minus direction, actual value of 2nd axis of the plane	mm
_OVR [14]	Trigger point in plus direction, actual value of 2nd axis of the plane	mm
_OVR [16]	Trigger point in minus direction, actual value of 3rd axis of the plane	mm
_OVR [18]	Trigger point in plus direction, actual value of 3rd axis of the plane	mm
_OVR [9]	Trigger point in minus direction, difference of 1st axis of the plane	mm
_OVR [11]	Trigger point in plus direction, difference of 1st axis of the plane	mm
_OVR [13]	Trigger point in minus direction, difference of 2nd axis of the plane	mm
_OVR [15]	Trigger point in plus direction, difference of 2nd axis of the plane	mm
_OVR [17]	Trigger point in minus direction, difference of 3rd axis of the plane	mm
_OVR [19]	Trigger point in plus direction, difference of 3rd axis of the plane	mm
_OVR [20]	Positional deviation of the 1st axis of the plane (probe skew)	mm
_OVR [21]	Positional deviation of the 2nd axis of the plane (probe skew)	mm
_OVR [22]	Probe length of the workpiece probe	mm
_OVR [24]	Angle at which the trigger points were determined	Degrees
_OVR [27]	Work offset range	mm
_OVR [28]	Safe area	mm
_OVI [2]	Measuring cycle number	-
_OVI [5]	Probe number	-
_OVI [9]	Alarm number	-

2.3.5 Edge distance - set edge (CYCLE978)

Function

This measuring variant determines the position of a paraxial edge in the workpiece coordinate system through 1-point measurement.

When using probes with side boom (L probe, type 713), towing measurement is possible in the positive direction of the tool axis.

With the "3D probe with spindle reversal" measuring method, measurement is performed in the axes of the plane as differential measurement. The special procedure for this measurement permits the use of an uncalibrated multidirectional probe. Probe types 712, 713 and 714 are not suitable for this purpose. A positionable spindle is mandatory.

With the "Align 3D probe" measuring method, the switching direction of the probe is always aligned to the current measuring direction. This function is recommended when high demands are placed on the measuring accuracy. Probe types 712, 713 and 714 are not suitable for this purpose. A positionable spindle is mandatory.

The measurement result (measurement difference) can be used as follows:

- Correction of a zero offset
- Offset of a tool
- Measurement without offset

Measuring principle

The measuring cycle determines the actual value of a measuring point, taking into account the calibration values, at one edge of the workpiece, referred to its zero point.

The difference between the actual value (measured value) and a specified setpoint in the parameterized measuring axis is calculated.

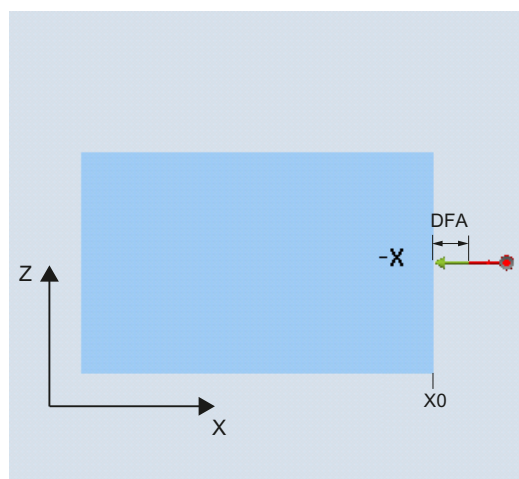

Measure: Edge (CYCLE978)
measuring direction: -X

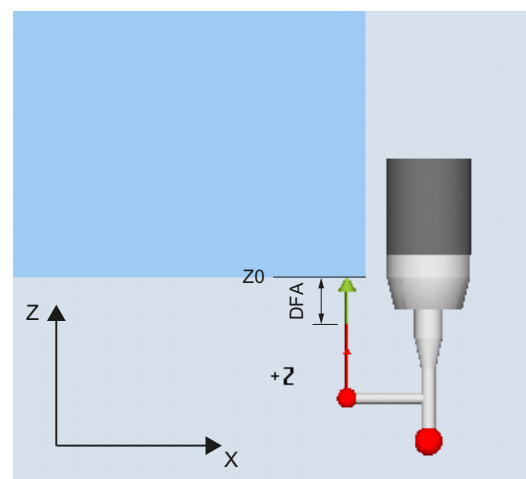

Measure: Edge (CYCLE978)
measuring direction: +Z (towing measurement)

Requirements

- The probe must be active as tool.
- Tool type of the probe:
 - 3D multi probe (type 710)
 - Mono probe (type 712)
 - L probe (type 713)

Note

L probe application (type 713)

Measurement is possible in +Z (towing measurement) or toward +X with the L probe.

The standard alignment of the L probe is toward +X (offset angle = 0). If the L probe is to be aligned in a different direction in the measuring program, this can be performed through a rotation around the tool axis (e.g. ROT Z = 90).

- When using the measuring version on lathes:
 - Only possible with tool type 580.
 - General MD 51740 \$MNS_MEA_FUNCTION_MASK, set bit1 = 0.

NOTICE

The following measuring methods are only possible in the axes of the plane:

- 3D probe with spindle reversal (differential measurement)
- Align 3D probe

The probe types 712, 713 and 714 generally **cannot** be used for these measuring methods.

Starting position before the measurement

The probe should be positioned at a distance that is somewhat greater than the measurement path (DFA) with respect to the surface to be measured.

Position after the end of the measuring cycle

After the measurement has been completed, the probe ball with its circumference is at a distance of the measuring path DFA with respect to the measuring surface.

Procedure

The part program or ShopMill program to be processed has been created and you are in the editor.



1. Press the "Meas. workpiece" softkey.











2. Press the "Edge distance" softkey.







3. Press the "Set edge" softkey.

The input window "Measure: Edge" is opened.

Parameters

G code program			ShopMill program		
Parameter	Description	Unit	Parameter	Description	Unit
Measuring method 	<ul style="list-style-type: none"> Standard measuring methods 3D probe with spindle reversal ¹⁾ Align 3D probe²⁾ 	-	T	Name of the probe	-
PL 	Measuring plane (G17 - G19)	-	D 	Cutting edge number (1 - 9)	-
 	Calibration data record (1 - 12) (only for measuring without spindle reversal)	-	Measuring method 	<ul style="list-style-type: none"> Standard measuring methods 3D probe with spindle reversal ¹⁾ Align 3D probe²⁾ 	-
			 	Calibration data record (1 - 12) (only for measuring without spindle reversal)	-
			X	Start point X of the measurement	mm
			Y	Start point Y of the measurement	mm
			Z	Start point Z of the measurement	mm

Parameter	Description	Unit
Correction target 	<ul style="list-style-type: none"> Measuring only (no offset) Zero offset (save measured value in a settable ZO) ³⁾ Tool offset (save measured value in the tool data) 	-
TR	Name of tool to be corrected	-
D 	Cutting edge number of tool to be corrected	-
Measuring direction 	Measuring axis <ul style="list-style-type: none"> +/- X +/- Y +/- Z 	-
X0 / Y0 / Z0	Setpoint (corresponding to the measuring direction)	mm
DFA	Measurement path	mm
TSA	Safe area for the measurement result	mm
Dimensional tolerance 	Use dimensional tolerance for tool offset (only for the "Tool offset" correction target) <ul style="list-style-type: none"> Yes No 	-
TUL	Upper tolerance limit, workpiece (only for dimensional tolerance "Yes")	mm
TLL	Lower tolerance limit, workpiece (only for dimensional tolerance "Yes")	mm

1) The "3D probe with spindle reversal" function is shown if bit 16 is set in the general SD 54760 \$SNS_MEA_FUNCTION_MASK_PIECE.

2) The "Align 3D probe" function is shown if bit 17 is set in the general SD 54760 \$SNS_MEA_FUNCTION_MASK_PIECE.

3) Other parameters and correction targets can be set in the general SD 54760 \$SNS_MEA_FUNCTION_MASK_PIECE.



Machine manufacturer

Please observe the machine manufacturer's instructions.

List of the result parameters

The measuring variant "Set edge" provides the following result parameters:

Table 2- 13 "Set edge" result parameters

Parameters	Description	Unit
_OVR [0]	Setpoint value for measuring axis	mm
_OVR [1]	Setpoint in 1st axis of the plane → only for S_MA=1	mm
_OVR [2]	Setpoint in 2nd axis of the plane → only for S_MA=2	mm
_OVR [3]	Setpoint in 3rd axis of the plane → only for S_MA=3	mm
_OVR [4]	Actual value for measuring axis	mm
_OVR [5]	Actual value in 1st axis of the plane → only for S_MA=1	mm
_OVR [6]	Actual value in 2nd axis of the plane → only for S_MA=2	mm
_OVR [7]	Actual value in 3rd axis of the plane → only for S_MA=3	mm
_OVR [16]	Difference for measuring axis	mm
_OVR [17]	Difference in 1st axis of the plane → only for S_MA=1	mm
_OVR [18]	Difference in 2nd axis of the plane → only for S_MA=2	mm
_OVR [19]	Difference in 3rd axis of the plane → only for S_MA=3	mm
_OVR [21]	Mean value	mm
_OVI [0]	D number or WO number	-
_OVI [2]	Measuring cycle number	-
_OVI [3]	Measuring version	-
_OVS_TNAME	Tool name	-

For workpiece measurement with tool offset or correction in the work offset, additional parameters are displayed, see Additional result parameters (Page 265).

2.3.6 Edge distance - align edge (CYCLE998)

Function

The workpiece lies in any direction, i.e. not parallel to the workpiece coordinate system (WCS) on the work table. By measuring two points on the workpiece reference edge that you have selected, you determine the angle to the active coordinate system. You can correct this angle as a rotation either in a geometry axis or as translational offset in a rotary axis (rotary table) in any ZO or in the active ZO.

Note

Maximum measured angle

Using the "Align edge" measuring version, a maximum angle of +/- 45 degrees can be measured.

Measuring principle

The Align edge measuring variant is performed according to the 1-angle measurement principle:

- For a clamped workpiece that is rotated in the plane, the angular offset is in the rotary part of the geometry axis that is located perpendicular to the measuring plane.

Example of G17 plane: Measuring axis X, offset axis Y

- Angular offset is realized in the Z rotation
- The rotation offset in the ZO is performed so that the actual position of the edge (actual value) and the desired setpoint angle (α) in the workpiece coordinate system must be taken into account.

- For a workpiece on a rotary table, the angular offset is added to the translatory offset of the rotary axis (table axis). The correction only makes sense if the rotary axis rotates around the geometry axis that is located perpendicular to the measuring plane.

Example of G17 plane: Measuring axis X, offset axis Y

- Angular offset is realized in the C axis. Rotary axis C rotates a rotary table around the Z axis.
- After the measurement, the rotary axis should be repositioned to align the workpiece.
- Example: G55 G0 C0.

For both correction versions, the translational components the ZO remain unchanged and should be redetermined after the edge has been aligned. This can be realized in a subsequent measuring program using the function "Set edge".

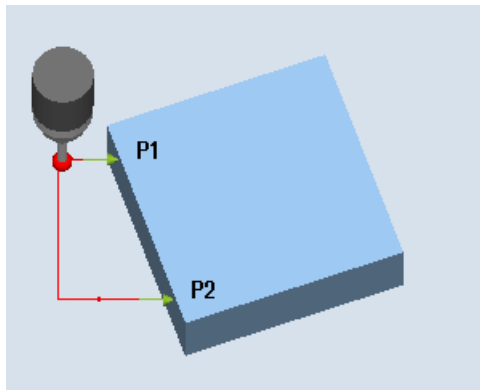

Measure: Align edge (CYCLE998), workpiece clamped in the plane

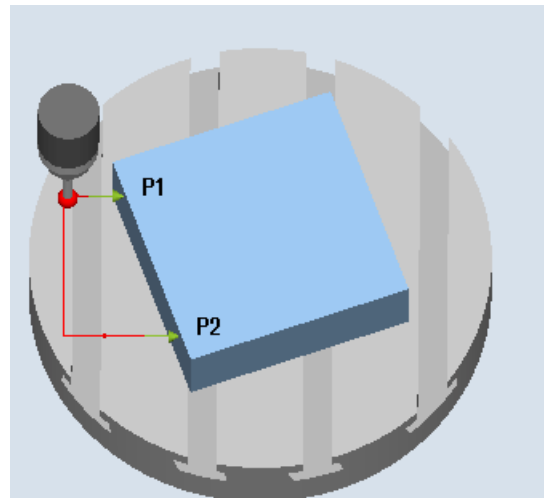

Measure: Align edge (CYCLE998), workpiece clamped on rotary table C axis

Measuring without spindle reversal

Precise measurement is only possible with a calibrated probe, i.e. machining plane, orientation of the spindle in the plane and measuring velocity are the same for both measurement and calibration. Deviations can cause additional measuring errors.

Measuring with spindle reversal

With measuring method "3D probe with spindle reversal", measuring point P1 is measured twice each with 180 degrees spindle reversal (probe rotated through 180 degrees). This means that the trigger points for the corresponding axis direction are currently being newly determined for this measurement (it is not necessary to calibrate the probe in the measuring direction). The measuring method "3D probe with spindle reversal" only makes sense for align edge of the axes in the working plane (for G17 XY).

The special procedure for this measurement permits the use of an uncalibrated multidirectional probe. Probe types 712, 713 and 714 are not suitable for this purpose. A positionable spindle is mandatory.

Requirements

- The probe must be called as a tool with a tool length compensation.
- Tool type of the probe:
 - 3D multi probe (type 710)
 - Mono probe (type 712)

Note

Precisely determining the angle requires the corresponding surface quality at least at one of the measuring points. The distances between the measuring points should be selected as high as possible.

NOTICE

The "3D probe with spindle reversal" function (differential measurement) is only possible in the axes of the plane. The probe types 712, 713 and 714 generally **cannot** be used for this measuring method.

Starting position before the measurement

Measuring axis and positioning axis (offset axis) can be preselected as required; however, they may not be the same.

Positioning taking into account a protection zone

- Protection zone = no

The probe is positioned in the measuring axis, as a maximum at the distance of measurement path DFA with respect to the surface to be measured in front of measuring point P1 at the measuring height.

- Protection zone = yes

The probe is positioned in the measuring axis as a maximum the distance from the measuring path DFA and the absolute value in parameter DX (for G17 and measuring axis X) with respect to the surface to be measured in front of measuring point P1 at the measuring height.

In both cases, when making the measurement, measuring point P1 must be able to be safely reached.

For the 1st measurement, if the distances from the reference edge are selected to be too large, then a measurement is not made.

Intermediate positioning from measuring point P1 to measuring point P2

Intermediate positioning "parallel to the edge"

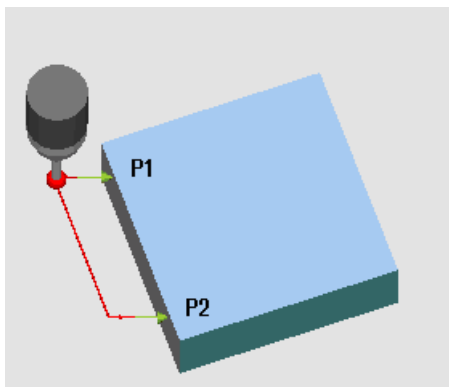

Figure 2-10 Aligning the edge (CYCLE998), intermediate positioning "parallel to the edge"

The probe travels parallel to the reference edge at the distance of parameter L2 in front of measuring point P2. In so doing, the angle from parameters α and TSA is taken into account. TSA contains the value for the maximum permissible angular deviation.

Intermediate positioning "parallel to the axis"

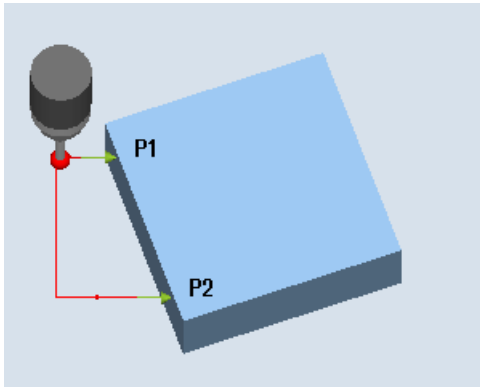

Figure 2-11 Aligning the edge (CYCLE998), intermediate positioning "parallel to the axis"

The probe travels parallel to the positioning axis (offset axis) at a distance of parameter L2 in front of measuring point P2.

Position after the end of the measuring cycle

After the end of measurement, the probe is at measuring point P2 at the distance of the measurement path DFA with respect to the measuring surface.

Procedure

The part program or ShopMill program to be processed has been created and you are in the editor.



1. Press the "Meas. workpiece" softkey.











2. Press the "Edge distance" softkey.









3. Press the "Align edge" softkey.

The input window "Measure: Align edge" is opened.

Parameters

G code program			ShopMill program		
Parameter	Description	Unit	Parameter	Description	Unit
Measuring method 	<ul style="list-style-type: none"> Standard measuring methods 3D probe with spindle reversal ¹⁾ 	-	T	Name of the probe	-
PL 	Measuring plane (G17 - G19)	-	D 	Cutting edge number (1 - 9)	-
 	Calibration data record (1 - 12) (only for standard measuring method)	-	Measuring method 	<ul style="list-style-type: none"> Standard measuring methods 3D probe with spindle reversal ¹⁾ 	-
			 	Calibration data record (1 - 12) (only for standard measuring method)	-
			X	Start point X of the measurement	mm
			Y	Start point Y of the measurement	mm
			Z	Start point Z of the measurement	mm

Parameter	Description	Unit
Correction target 	<ul style="list-style-type: none"> Measuring only (no offset) Zero offset (save measured values in a settable ZO) ²⁾ 	-
Angular offset  (only for "zero offset")	Offset results in: <ul style="list-style-type: none"> Coordinate system rotation Rotary axis rotation C ³⁾ 	-
Positioning 	Position probe: <ul style="list-style-type: none"> Parallel to the axis Parallel to the edge 	-
Measuring direction 	Measuring axis <ul style="list-style-type: none"> (+/-) X (+/-) Y (+/-) Z 	-
Positioning axis 	Offset axis (Note: Measuring axis and offset axis may not be the same!) <ul style="list-style-type: none"> X Y Z 	-
α	Angle between positioning axis and edge ⁴⁾	Degrees
L2	Distance to the 2nd measuring point ⁵⁾	mm
Protection zone 	Use protection zone <ul style="list-style-type: none"> Yes No 	-
DX / DY / DZ (corresponding to the measuring direction)	Distance to the edge for measuring point 1 (only for protection zone "Yes")	mm

2.3 Measure workpiece (milling)

Parameter	Description	Unit
DFA	Measurement path	mm
TSA	Safe area for the measurement result	Degrees

- 1) The "3D probe with spindle reversal" function is shown if bit 16 is set in the general SD 54760 \$SNS_MEA_FUNCTION_MASK_PIECE .
- 2) Other parameters and correction targets can be set in the general SD 54760 \$SNS_MEA_FUNCTION_MASK_PIECE .
- 3) To display the corresponding rotary axis as offset target, bit 6 must be set to 1 in the channel-specific MD 52207 \$MCS_AXIS_USAGE_ATTRIB.
- 4) By specifying the measuring axis in parameter **measuring direction**, then all 3 measuring planes are possible. Setpoint angle α therefore refers to the positive direction of the offset axis and is negative in the clockwise sense, positive in the counter-clockwise sense.
Setpoint angle α specifies the required angle between the edge and the positive direction of the offset axis. For $\alpha=0$ ($s_{STA}=0$) , after correction, regarding the offset axis, the edge is parallel to the axis.
When positioning "Parallel to the edge", angle α is also used for positioning. The positioning angle is generated together with parameter **TSA**. Parameter α should therefore only deviate a small amount from the measured angle!
- 5) With parameter **L2** (s_{ID}) the distance in the offset axis between P1 and P2 is defined. Only positive values are permissible for **L2**. Accordingly, P1 should be selected in the offset axis at the beginning of the cycle.



Machine manufacturer

Please observe the machine manufacturer's instructions.

List of the result parameters

The measuring variant "Align edge" provides the following result parameters:

Table 2- 14 "Align edge" result parameters

Parameters	Description	Unit
_OVR [0]	Angle setpoint	Degrees
_OVR [4]	Angle actual value	Degrees
_OVR [16]	Angle difference	Degrees
_OVR [20]	Angle offset value	Degrees
_OVR [28]	Safe area	Degrees
_OVR [30]	Empirical value	Degrees
_OVI [0]	WO number	-
_OVI [2]	Measuring cycle number	-
_OVI [5]	Probe number	-
_OVI [7]	Empirical value memory number	-
_OVI [9]	Alarm number	-

2.3.7 Edge distance - groove (CYCLE977)

Function

This measuring version can be used to measure a groove in a workpiece. The groove width is measured and the groove center point determined. Measurements at an inclined groove are also possible. To do this, an angle corresponding to the actual angularity of the groove position should be entered into the parameterizing screen form. Probing at the groove edge always takes place at right angles. A protection zone can be defined in the groove.

With the "3D probe with spindle reversal" measuring method, measurement is performed in the axes of the plane as differential measurement. The special procedure for this measurement permits the use of an uncalibrated multidirectional probe. Probe types 712, 713 and 714 are not suitable for this purpose. A positionable spindle is mandatory.

With the "Align 3D probe" measuring method, the switching direction of the probe is always aligned to the current measuring direction. This function is recommended when high demands are placed on the measuring accuracy. Probe types 712, 713 and 714 are not suitable for this purpose. A positionable spindle is mandatory.

The measurement result (measurement difference) can be used as follows:

- Correction of a ZO so that the workpiece zero point is in relation to the groove center point.
- Offset of a tool,
- Measurement without offset

Measuring principle

One point at each of the opposite edges of the slot are measured based on the selected measuring axis. The positive direction of the geometry axis is measured first.

From the two actual positions, taking into account the calibration values, the groove width is calculated.

The position of the groove center as workpiece zero is determined corresponding to the zero offset selected to be corrected.

The measured difference of the groove width is used as basic variable for a tool offset, the position of groove zero point, as basis of a zero offset.

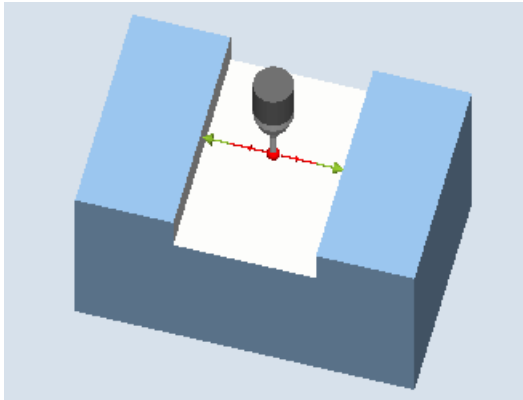

Measure: Groove (CYCLE977)

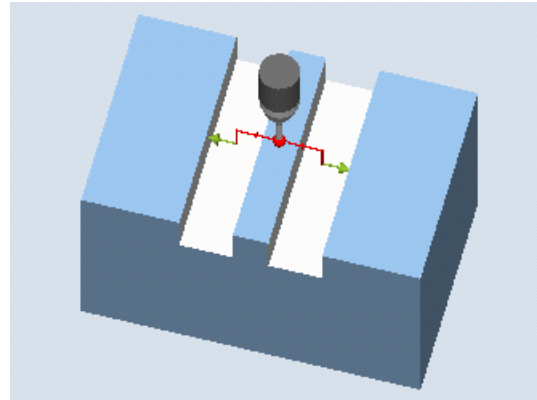

Measure: Groove with protection zone (CYCLE977)

Requirements

- The probe must be active as tool.
- Tool type of the probe:
 - 3D multi probe (type 710)
 - Mono probe (type 712)

NOTICE

The following measuring methods are only possible in the axes of the plane:

- 3D probe with spindle reversal (differential measurement)
- Align 3D probe

The probe types 712, 713 and 714 generally **cannot** be used for these measuring methods.

Starting position before the measurement

The probe should be positioned with the probe ball center in the measuring axis approximately at the center of the groove and at the measuring height. For a protection zone, the probe ball should be positioned in the measuring axis approximately centered to the groove and at a height above the protection zone. With the infeed path that has been entered, it must be guaranteed that from this height the desired measuring height in the groove can be reached.

Note

If too large a measurement path DFA has been selected so that the protection zone is violated, then the distance is reduced automatically in the cycle. However, there must be sufficient room for the probe ball.

Position after the end of the measuring cycle

Without activated protection zone, the probe ball is at the measuring height in the center of the groove. With protection zone, the probe ball is centered with respect to the groove over the protection zone at the starting position of the measuring cycles.

Procedure

The part program or ShopMill program to be processed has been created and you are in the editor.



1. Press the "Meas. workpiece" softkey.



2. Press the "Edge distance" softkey.

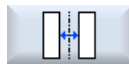

3. Press the "Groove" softkey.



The input window "Measure: Groove" is opened.

Parameters

G code program			ShopMill program		
Parameter	Description	Unit	Parameter	Description	Unit
Measuring method	<ul style="list-style-type: none"> Standard measuring methods 3D probe with spindle reversal ¹⁾ Align 3D probe²⁾ 	-	T	Name of the probe	-
PL	Measuring plane (G17 - G19)	-	D	Cutting edge number (1 - 9)	-
	Calibration data record (1 - 12) (only for measuring without spindle reversal)	-	Measuring method	<ul style="list-style-type: none"> Standard measuring methods 3D probe with spindle reversal ¹⁾ Align 3D probe²⁾ 	-
				Calibration data record (1 - 12) (only for measuring without spindle reversal)	-
			X	Start point X of the measurement	mm
			Y	Start point Y of the measurement	mm
			Z	Start point Z of the measurement	mm

Parameter	Description	Unit
Correction target	<ul style="list-style-type: none"> Measuring only (no offset) Zero offset (save measured values in a settable ZO) ³⁾ Tool offset (save measured values in the tool data) 	-
TR	Name of tool to be corrected	-
D	Cutting edge number of tool to be corrected	-

2.3 Measure workpiece (milling)

Parameter	Description	Unit
Measuring axis 	Measuring axis (for G17): <ul style="list-style-type: none"> • X • Y 	-
W	Groove width setpoint	mm
α0	Angle between measuring axis and workpiece	Degrees
Protection zone 	Use protection zone <ul style="list-style-type: none"> • Yes • No 	-
only for protection zone "Yes":		
WS	Width of the protection zone	mm
DZ	Infeed distance at measuring height (for G17)	mm
DFA	Measurement path	mm
TSA	Safe area for the measurement result	mm
Dimensional tolerance 	Use dimensional tolerance for tool offset (only for the "Tool offset" correction target) <ul style="list-style-type: none"> • Yes • No 	-
TUL	Upper tolerance limit, workpiece (only for dimensional tolerance"Yes")	mm
TLL	Lower tolerance limit, workpiece (only for dimensional tolerance"Yes")	mm

- 1) The "3D probe with spindle reversal" function is shown if bit 16 is set in the general SD 54760 \$SNS_MEA_FUNCTION_MASK_PIECE.
- 2) The "Align 3D probe" function is shown if bit 17 is set in the general SD 54760 \$SNS_MEA_FUNCTION_MASK_PIECE.
- 3) Other parameters and correction targets can be set in the general SD 54760 \$SNS_MEA_FUNCTION_MASK_PIECE.



Machine manufacturer

Please observe the machine manufacturer's instructions.

List of the result parameters

The measuring variant "Groove" provides the following result parameters:

Table 2- 15 "Groove" result parameters

Parameters	Description	Unit
_OVR [0]	Groove width setpoint	mm
_OVR [1]	Setpoint, groove center in the 1st axis of the plane	mm
_OVR [2]	Setpoint, groove center in the 2nd axis of the plane	mm
_OVR [4]	Groove width actual value	mm
_OVR [5]	Actual value, groove center in the 1st axis of the plane	mm
_OVR [6]	Actual value, groove center in the 2nd axis of the plane	mm
_OVR [16]	Groove width difference	mm
_OVR [17]	Difference, groove center in the 1st axis of the plane	mm
_OVR [18]	Difference, groove center in the 2nd axis of the plane	mm
_OVI [0]	D number or WO number	-
_OVI [2]	Measuring cycle number	-
_OVI [3]	Measuring version	-
_OVS_TNAME	Tool name	-

For workpiece measurement with tool offset or correction in the work offset, additional parameters are displayed, see Additional result parameters (Page 265).

2.3.8 Edge distance - rib (CYCLE977)

Function

This measuring variant can be used to measure a rib on a workpiece. The rib width is measured and the rib center point is determined.

Measurements at an inclined rib are also possible. To do this, an angle corresponding to the actual angularity of the rib position should be entered into the parameterizing screen form. Probing at the rib edge always takes place at right angles. A protection zone can be defined at the side of the rib.

With the "3D probe with spindle reversal" measuring method, measurement is performed in the axes of the plane as differential measurement. The special procedure for this measurement permits the use of an uncalibrated multidirectional probe. Probe types 712, 713 and 714 are not suitable for this purpose. A positionable spindle is mandatory.

With the "Align 3D probe" measuring method, the switching direction of the probe is always aligned to the current measuring direction. This function is recommended when high demands are placed on the measuring accuracy. Probe types 712, 713 and 714 are not suitable for this purpose. A positionable spindle is mandatory.

The measurement result (measurement difference) can be used as follows:

- Correction of a ZO so that the workpiece zero point is in relation to the rib center point.
- Offset of a tool
- Measurement without offset

Measuring principle

One point at each of the opposite edges of the rib are measured based on the selected measuring axis. The positive direction of the geometry axis is measured first. From the two actual positions, taking into account the calibration values, the rib width is calculated. The position of the rib center as workpiece zero is determined corresponding to the zero offset selected to be corrected.

The measured difference of the rib width is used as basic variable for a tool offset, the position of rib zero point, as basis of a zero offset.

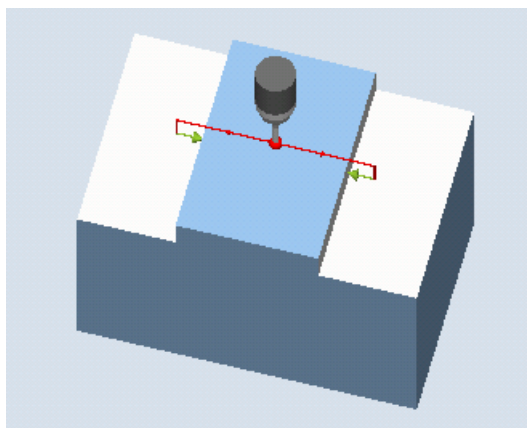

Measure: Rib (CYCLE977)

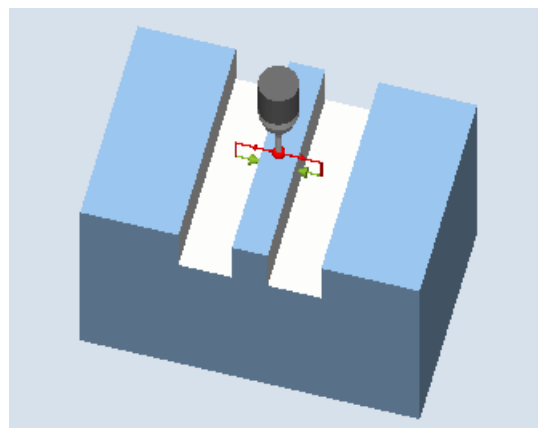

Measure: Rib with a protection zone (CYCLE977)

Requirements

- The probe must be active as tool.
- Tool type of the probe:
 - 3D multi probe (type 710)
 - Mono probe (type 712)

NOTICE

The following measuring methods are only possible in the axes of the plane:

- 3D probe with spindle reversal (differential measurement)
- Align 3D probe

The probe types 712, 713 and 714 generally **cannot** be used for these measuring methods.

Starting position before the measurement

The probe should be positioned with the probe ball center in the measuring axis approximately above the center of the rib. With the entered infeed path, it must be ensured that from the starting height the required measuring height at the rib is reached.

Note

If too large a measurement path DFA has been selected so that the protection zone is violated, then the distance is reduced automatically in the cycle. However, there must be sufficient room for the probe ball.

Position after the end of the measuring cycle

The probe ball is centered above the rib at the height of the starting position of the measuring cycles.

Procedure

The part program or ShopMill program to be processed has been created and you are in the editor.



1. Press the "Meas. workpiece" softkey.





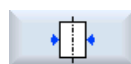









2. Press the "Edge distance" softkey.



3. Press the "Rib" softkey.
The input window "Measure: Rib" is opened.

Parameters

G code program			ShopMill program		
Parameter	Description	Unit	Parameter	Description	Unit
Measuring method 	<ul style="list-style-type: none"> Standard measuring methods 3D probe with spindle reversal ¹⁾ Align 3D probe²⁾ 	-	T	Name of the probe	-
PL 	Measuring plane (G17 - G19)	-	D 	Cutting edge number (1 - 9)	-
 	Calibration data record (1 - 12) (only for measuring without spindle reversal)	-	Measuring method 	<ul style="list-style-type: none"> Standard measuring methods 3D probe with spindle reversal ¹⁾ Align 3D probe²⁾ 	-
			 	Calibration data record (1 - 12) (only for measuring without spindle reversal)	-
			X	Start point X of the measurement	mm
			Y	Start point Y of the measurement	mm
			Z	Start point Z of the measurement	mm

Parameter	Description	Unit
Correction target 	<ul style="list-style-type: none"> Measuring only (no offset) Zero offset (save measured values in a settable ZO) ³⁾ Tool offset (save measured values in the tool data) 	-
TR	Name of tool to be corrected	-
D 	Cutting edge number of tool to be corrected	-
Measuring axis 	Measuring axis (for measuring plane G17) <ul style="list-style-type: none"> X Y 	-
W	Rib width setpoint	mm
α0	Angle between measuring axis and workpiece	Degrees
DZ	Infeed distance at measuring height (for measuring plane G17)	mm
Protection zone 	Use protection zone <ul style="list-style-type: none"> Yes No 	-
WS	Width of the protection zone (only for protection zone "Yes")	mm
DFA	Measurement path	mm
TSA	Safe area for the measurement result	mm
Dimensional tolerance 	Use dimensional tolerance for tool offset <ul style="list-style-type: none"> Yes No 	-

Parameter	Description	Unit
TUL	Upper tolerance limit, workpiece (only for dimensional tolerance"Yes")	mm
TLL	Lower tolerance limit, workpiece (only for dimensional tolerance"Yes")	mm

- 1) The "3D probe with spindle reversal" function is shown if bit 16 is set in the general SD 54760 \$SNS_MEA_FUNCTION_MASK_PIECE.
- 2) The "Align 3D probe" function is shown if bit 17 is set in the general SD 54760 \$SNS_MEA_FUNCTION_MASK_PIECE.
- 3) Other parameters and correction targets can be set in the general SD 54760 \$SNS_MEA_FUNCTION_MASK_PIECE.



Machine manufacturer

Please observe the machine manufacturer's instructions.

List of the result parameters

The measuring variant "Rib" provides the following result parameters:

Table 2- 16 "Rib" result parameters

Parameters	Description	Unit
_OVR [0]	Rib width setpoint	mm
_OVR [1]	Rib center setpoint in the 1st axis of the plane	mm
_OVR [2]	Rib center setpoint in the 2nd axis of the plane	mm
_OVR [4]	Rib width actual value	mm
_OVR [5]	Rib center actual value in the 1st axis of the plane	mm
_OVR [6]	Rib center actual value in the 2nd axis of the plane	mm
_OVR [16]	Rib width difference	mm
_OVR [17]	Rib center difference in the 1st axis of the plane	mm
_OVR [18]	Rib center difference in the 2nd axis of the plane	mm
_OVI [0]	D number or WO number	-
_OVI [2]	Measuring cycle number	-
_OVI [3]	Measuring version	-
_OVS_TNAME	Tool name	-

For workpiece measurement with tool offset or correction in the work offset, additional parameters are displayed, see Additional result parameters (Page 265).

2.3.9 Corner - right-angled corner (CYCLE961)

Function

This measuring variant can be used to measure a right-angled inside or outside corner of a workpiece. The measurements are performed paraxially to the active workpiece coordinate system.

In addition to the measurement, the position of the corner can be used as workpiece zero in a specified zero offset (ZO).

Measuring principle

The measuring cycle moves to three measuring points and determines the point of intersection of the resulting straight lines and the angle of rotation to the positive 1st axis of the actual plane. The corner to be calculated can be offset.

The result, the position of the corner is saved as an absolute value in the result parameters `_OVR[]` and optionally in the specified zero offset (offset and rotation). The measured corner is shifted by the values in setpoint parameter (X0, Y0 for G17) in the workpiece coordinate system in the plane.

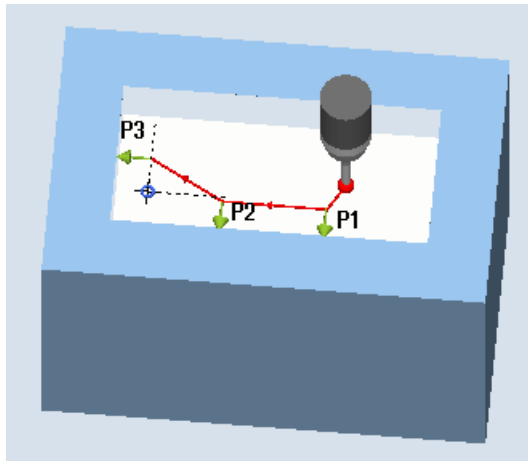

Measure: Right-angled corner, inner (CYCLE961)

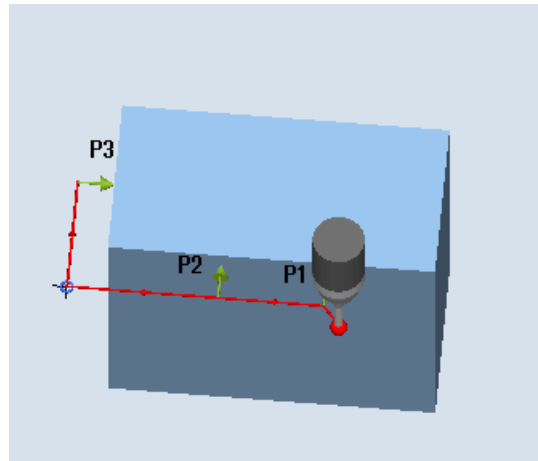

Measure: Right-angled corner, outer (CYCLE961)

Requirements

- The probe must be called as a tool with a tool length compensation.
- Tool type of the probe:
 - 3D multi probe (type 710)
 - Mono probe (type 712)

Starting position before the measurement

The probe is at the measuring height or above the corner (see protection zone) compared to the corner to be measured or in front of the 1st measuring point.

The measuring points must be able to be approached from here collision-free.

The measuring points are derived from the programmed distances L1 to L3 and the pole position (XP, YP). When positioning, α_0 (angle between the X axis and 1st edge in the machine coordinate system) is also taken into account.

The measuring cycle generates the required traversing blocks and performs the measurements at the measuring points P1 to P3, starting with P1.

Positioning measuring points P1 to P3 taking into account a protection zone

- Protection zone = no

The probe is pre-positioned at the measuring height and remains at this measuring height when measuring the corner. An outer corner is traversed around.

- Protection zone = yes

The probe is pre-positioned above the corner. When measuring, the 3rd axis of the plane (Z for G17) is moved by the value in parameter DZ to the measuring height and the corresponding measuring point is measured. After the measurement, the probe is raised by the value of parameter DZ and moves to the next measuring point, where it is lowered again.

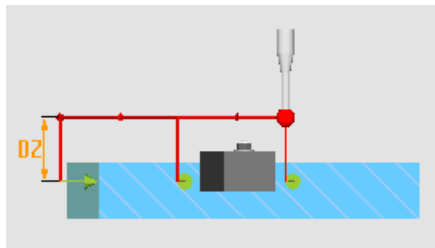

Figure 2-12 Protection zone = yes Traversing around the outer corner with $DZ > 0$ (measuring height + DZ) for G17

Position after the end of the measuring cycle

The probe is at the starting position again (opposite the measured corner).

Depending on the protection zone parameter yes/no, the probe is at the measuring height or above the corner.

Procedure

The part program or ShopMill program to be processed has been created and you are in the editor.



1. Press the "Meas. workpiece" softkey.



2. Press the "Corner" softkey.



3. Press the "Right-angled corner" softkey.
The input window "Measure: Right-angled corner" is opened.

Parameters

G code program			ShopMill program		
Parameters	Description	Unit	Parameters	Description	Unit
PL	Measuring plane (G17 - G19)	-	T	Name of the probe	-
	Calibration data set (1 - 12)	-	D	Cutting edge number (1 - 9)	-
				Calibration data set (1 - 12)	-
			X	Start point X of the measurement	mm
			Y	Start point Y of the measurement	mm
			Z	Start point Z of the measurement	mm

Parameters	Description	Unit		
Correction target	<ul style="list-style-type: none"> Measuring only (no offset) Work offset (save measured values in an adjustable WO) ¹⁾ 	-		
Position	Type of corner:	-		
	<table border="0"> <tr> <td>Outside corner</td> <td>Inside corner</td> </tr> </table>	Outside corner	Inside corner	-
Outside corner	Inside corner			
Position of the corner	<table border="0"> <tr> <td> <ul style="list-style-type: none"> </td> <td> <ul style="list-style-type: none"> </td> </tr> </table>	<ul style="list-style-type: none"> 	<ul style="list-style-type: none"> 	-
<ul style="list-style-type: none"> 	<ul style="list-style-type: none"> 			
X0	Setpoint X of the corner (for measuring plane G17)	mm		
Y0	Setpoint Y of the corner (for measuring plane G17)	mm		
XP	Pole (for measuring plane G17)	mm		
YP	Pole (for measuring plane G17)	mm		
$\alpha 0$	Angle between Y or Z axis and the 1st edge (for measuring plane G17)	Degrees		
L1	Distance between the pole and measuring point P1 in the direction of the 1st axis of the plane (for G17, X)	mm		

Parameters	Description	Unit
L2	Distance between the pole and measuring point P2 in the direction of the 1st axis of the plane	mm
L3	Distance between the pole and measuring point P3 in the direction of the 2nd axis of the plane (for G17, Y)	mm
Protection zone 	Use protection zone <ul style="list-style-type: none"> • Yes • No 	-
DZ	Infeed distance at measuring height (only for protection zone "Yes")	mm
DFA	Measurement path	mm
TSA	Safe area for the measurement result	mm

1) Other parameters and correction targets can be set in the general SD 54760 \$SNS_MEA_FUNCTION_MASK_PIECE.



Machine manufacturer

Please observe the machine manufacturer's instructions.

List of the result parameters

The measuring variant "Right-angled corner" provides the following result parameters:

Table 2- 17 "Right-angled corner" result parameters

Parameters	Description	Unit
_OVR [4]	Angle actual value to the 1st axis of the plane in the workpiece coordinate system (WCS)	Degrees
_OVR [5]	Corner point actual value in the 1st axis of the plane in the WCS	mm
_OVR [6]	Corner point actual value in the 2nd axis of the plane in the WCS	mm
_OVR [20]	Angle actual value to the 1st axis of plane in the machine coordinate system (MCS) ¹⁾	Degrees
_OVR [21]	Corner point actual value in the 1st axis of the plane in the MCS ¹⁾	mm
_OVR [22]	Corner point actual value in the 2nd axis of the plane in the MCS ¹⁾	mm
_OVI [2]	Measuring cycle number	-
_OVI [3]	Measuring version	-
_OVI [5]	Probe number	-
_OVI [9]	Alarm number	-

1) For deactivated transformation, otherwise basic coordinate system

2.3.10 Corner - any corner (CYCLE961)

Function

This measuring variant can be used to measure the inside or outside corner of an unknown workpiece geometry. The measurements are performed paraxially to the active workpiece coordinate system.

In addition to the measurement, the position of the corner can be used as workpiece zero in a specified zero offset (ZO).

Measuring principle

The measuring cycle traverses to the four measuring points (P1 to P4) one after the other and establishes the point of intersection of the resulting straight lines and the angle of rotation to the reference edge of measuring points P1 and P2 to the 1st axis of the plane (X for G17) in the positive direction

The result, the position of the corner is saved as an absolute value in the result parameters `_OVR[]` and optionally in the specified zero offset (offset and rotation). The measured corner is shifted by the values in setpoint parameter (X0, Y0 for G17) in the workpiece coordinate system in the plane.

The position of points P1 and P2 in relation to each other determines the direction of the 1st axis of the plane of the new coordinate system.

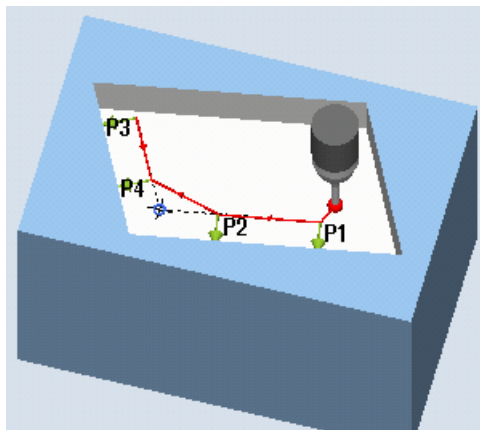

Measure: Any corner, inside (CYCLE961)

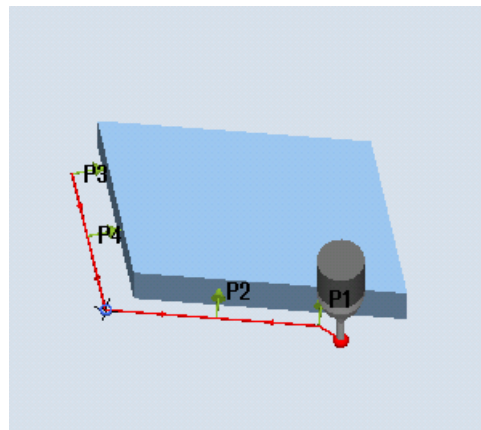

Measure: Any corner, outside (CYCLE961)

Requirements

- The probe must be called as a tool with a tool length compensation.
- Tool type of the probe: 3D multi probe (type 710)

Starting position before the measurement

The probe is at the measuring height or above the corner (see protection zone) compared to the corner to be measured or in front of the 1st measuring point.

The measuring points must be able to be approached from here collision-free.

The measuring cycle generates the required traversing blocks and performs the measurements at the measuring points P1 to P4, starting with P1.

Positioning measuring points P1 to P4 taking into account a protection zone

- Protection zone = no

The probe is pre-positioned at the measuring height and remains at this measuring height when measuring the corner. An outer corner is traversed around.

- Protection zone = yes

The probe is pre-positioned above the corner. When measuring, the 3rd axis of the plane (Z for G17) is moved by the value in parameter DZ to the measuring height and the corresponding measuring point is measured. After the measurement, the probe is raised by the value of parameter DZ and moves to the next measuring point, where it is lowered again.

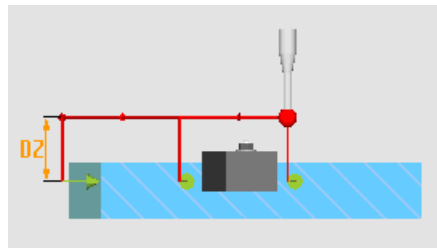

Figure 2-13 Protection zone = yes Traversing around the outer corner with $DZ > 0$ (measuring height + DZ) for G17

Position after the end of the measuring cycle

After the last measurement, the probe is at measuring point P4.

Depending on the protection zone parameter (yes/no), the probe is at the measuring height or above the corner.

Procedure

The part program or ShopMill program to be processed has been created and you are in the editor.



1. Press the "Meas. workpiece" softkey.



2. Press the "Corner" softkey.



3. Press the "Any corner" softkey.

The input window "Measure: Any corner" is opened.

Parameters

G code program			ShopMill program		
Parameters	Description	Unit	Parameters	Description	Unit
PL	Measuring plane (G17 - G19)	-	T	Name of the probe	-
	Calibration data set (1 - 12)	-	D	Cutting edge number (1 - 9)	-
				Calibration data set (1 - 12)	-
			X	Start point X of the measurement	mm
			Y	Start point Y of the measurement	mm
			Z	Start point Z of the measurement	mm

Parameters	Description	Unit	
Correction target	<ul style="list-style-type: none"> Measuring only (no offset) Work offset (save measured values in an adjustable WO) ¹⁾ 	-	
Coordinate system	<ul style="list-style-type: none"> Polar Right-angled 	-	
Position	Type of corner:	-	
	Outside corner	Inside corner	-
Position of the corner	<ul style="list-style-type: none"> 	<ul style="list-style-type: none"> 	-
X0	Setpoint X of the measured corner (X for G17)	mm	
Y0	Setpoint Y of the measured corner (X for G17)	mm	
Only for coordinate system = "Polar":			
XP	Position of the pole in the 1st axis of the plane (X for G17)	mm	
YP	Position of the pole in the 2nd axis of the plane (Y for G17)	mm	
$\alpha 0$	Angle between X axis and the 1st edge (for G17)	Degrees	
L1	Distance to the start point of the 1st measurement	mm	
L2	Distance to the start point of the 2nd measurement	mm	
$\alpha 1$	Opening angle	Degrees	
L3	Distance to the start point of the 3rd measurement	mm	
L4	Distance to the start point of the 4th measurement	mm	
Only for coordinate system = "Right-angled":			
X1	Start point X of the 1st measurement	mm	
Y1	Start point Y of the 1st measurement	mm	
X2	Start point X of the 2nd measurement	mm	
Y2	Start point Y of the 2nd measurement	mm	
X3	Start point X of the 3rd measurement	mm	
Y3	Start point Y of the 3rd measurement	mm	

Parameters	Description	Unit
X4	Start point X of the 4th measurement	mm
Y4	Start point Y of the 4th measurement	mm
Protection zone 	Use protection zone <ul style="list-style-type: none"> • Yes • No 	-
DZ	Infeed distance at measuring height (only for protection zone "Yes")	mm
DFA	Measurement path	mm
TSA	Safe area for the measurement result	mm

1) Other parameters and correction targets can be set in the general SD 54760 \$SNS_MEA_FUNCTION_MASK_PIECE.



Machine manufacturer

Please observe the machine manufacturer's instructions.

Note

The 4 measuring points or the measuring path DFA must be selected so that contour within the total path: $2 \cdot \text{DFA}$ [in mm] is reached. Otherwise, no measurement will be able to be made.

Internally in the cycle, a minimum value of 20 mm for the measurement distance DFA is generated.

List of the result parameters

The measuring variant "Any corner" provides the following result parameters:

Table 2- 18 "Any corner" result parameters

Parameters	Description	Unit
_OVR [4]	Angle actual value to the 1st axis of the plane in the workpiece coordinate system (WCS)	Degrees
_OVR [5]	Corner point actual value in the 1st axis of the plane in the WCS	mm
_OVR [6]	Corner point actual value in the 2nd axis of the plane in the WCS	mm
_OVR [20]	Angle actual value to the 1st axis of plane in the machine coordinate system (MCS) ¹⁾	Degrees
_OVR [21]	Corner point actual value in the 1st axis of the plane in the MCS ¹⁾	mm
_OVR [22]	Corner point actual value in the 2nd axis of the plane in the MCS ¹⁾	mm
_OVI [2]	Measuring cycle number	-
_OVI [3]	Measuring version	-
_OVI [5]	Probe number	-
_OVI [9]	Alarm number	-

1) For deactivated transformation, otherwise basic coordinate system

2.3.11 Hole - rectangular pocket (CYCLE977)

Function

This measuring version can be used to measure a rectangular pocket in a workpiece. The pocket width and the pocket length are measured and the pocket center point is determined.

Measurements are also possible at a rectangular pocket (horizontal) rotated in the working plane. To do this, an angle corresponding to the real pocket position must be entered into the parameterizing screen form. The probing at the sides of the pocket is always at right angles. A protection zone can be defined in the pocket.

With the "3D probe with spindle reversal" measuring method, measurement is performed in the axes of the plane as differential measurement. The special procedure for this measurement permits the use of an uncalibrated multidirectional probe. Probe types 712, 713 and 714 are not suitable for this purpose. A positionable spindle is mandatory.

With the "Align 3D probe" measuring method, the switching direction of the probe is always aligned to the current measuring direction. This function is recommended when high demands are placed on the measuring accuracy. Probe types 712, 713 and 714 are not suitable for this purpose. A positionable spindle is mandatory.

The measurement result (measurement difference) can be used as follows:

- Correction of a ZO so that the workpiece zero point is in relation to the center point of the rectangle
- Offset of a tool
- Measurement without offset

Measuring principle

Two opposite points in each of the two geometry axes of the plane are measured. The measurements start in the positive direction of the 1st geometry axis. From the four measured actual positions of the pocket sides, the pocket width and the pocket length are calculated, taking into account the calibration values. The position of the pocket center as workpiece zero is determined corresponding to the zero offset selected to be corrected. The measuring differences of the side lengths are used as the basic quantity for a tool offset, the position of the pocket zero point as basis for the zero offset.

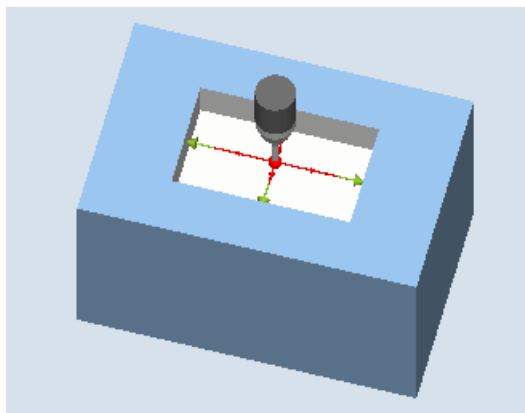

Measure: Rectangular pocket (CYCLE977)

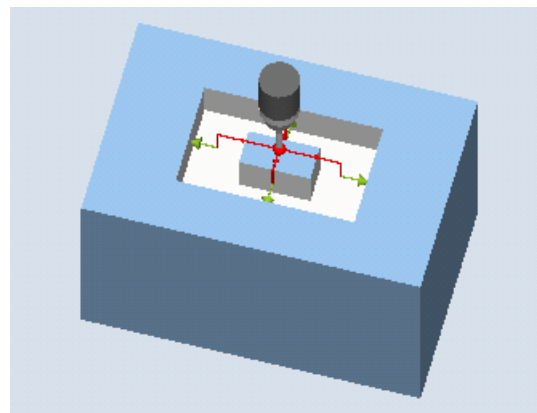

Measure: Rectangular pocket with protection zone (CYCLE977)

Requirements

- The probe must be active as tool.
- Tool type of the probe:
 - 3D multi probe (type 710)
 - Mono probe (type 712)

NOTICE

The following measuring methods are only possible in the axes of the plane:

- 3D probe with spindle reversal (differential measurement)
- Align 3D probe

The probe types 712, 713 and 714 generally **cannot** be used for these measuring methods.

Starting position before the measurement

The probe should be positioned with the probe ball center approximately at the center of the pocket at the measuring height.

For a protection zone, the probe ball center is positioned approximately centered to the pocket and at a height above the protection zone.

With the infeed path that has been entered, it must be guaranteed that from this height the desired measuring height in the pocket can be reached.

NOTICE

If too large a measurement path DFA has been selected so that the protection zone is violated, then the distance is reduced automatically in the cycle. However, there must be sufficient room for the probe ball.

Position after the end of the measuring cycle

Without activated protection zone, at the end of the measuring cycle, the probe ball is at the measuring height in the center of the pocket.

With a protection zone, at the end of the measuring cycle, the probe ball is centered above the pocket at the height of the starting position of the measuring cycles.

Procedure

The part program or ShopMill program to be processed has been created and you are in the editor.











1. Press the "Meas. workpiece" softkey.





2. Press the "Hole" softkey.

3. Press the "Rectangular pocket" softkey.

The input window "Measure: rectangular pocket" is opened.

Parameters

G code program			ShopMill program		
Parameter	Description	Unit	Parameter	Description	Unit
Measuring method 	<ul style="list-style-type: none"> Standard measuring methods 3D probe with spindle reversal ¹⁾ Align 3D probe²⁾ 	-	T	Name of the probe	-
PL 	Measuring plane (G17 - G19)	-	D 	Cutting edge number (1 - 9)	-
 	Calibration data record (1 - 12) (only for measuring without spindle reversal)	-	Measuring method 	<ul style="list-style-type: none"> Standard measuring methods 3D probe with spindle reversal ¹⁾ Align 3D probe²⁾ 	-
			 	Calibration data record (1 - 12) (only for measuring without spindle reversal)	-
			X	Start point X of the measurement	mm
			Y	Start point Y of the measurement	mm
			Z	Start point Z of the measurement	mm

Parameter	Description	Unit
Correction target 	<ul style="list-style-type: none"> Measuring only (no offset) Zero offset (save measured values in a settable ZO) ³⁾ Tool offset (save measured values in the tool data) 	-
TR	Name of tool to be corrected	-
D 	Cutting edge number of tool to be corrected	-
W	Pocket width setpoint	mm
L	Pocket length setpoint	mm
α0	Angle between measuring axis and workpiece	Degrees
Protection zone 	Use protection zone <ul style="list-style-type: none"> Yes No 	-
WS	Width of the protection zone (only for protection zone "Yes")	mm
LS	Length of the protection zone (only for protection zone "Yes")	mm
DX / DY / DZ	Infeed distance at measuring height (only for protection zone "Yes")	mm
DFA	Measurement path	mm
TSA	Safe area for the measurement result	mm
Dimensional tolerance 	Use dimensional tolerance for tool offset <ul style="list-style-type: none"> Yes No 	-

Parameter	Description	Unit
TUL	Upper tolerance limit, workpiece (only for dimensional tolerance"Yes")	mm
TLL	Lower tolerance limit, workpiece (only for dimensional tolerance"Yes")	mm

- 1) The "3D probe with spindle reversal" function is shown if bit 16 is set in the general SD 54760 \$SNS_MEA_FUNCTION_MASK_PIECE.
- 2) The "Align 3D probe" function is shown if bit 17 is set in the general SD 54760 \$SNS_MEA_FUNCTION_MASK_PIECE.
- 3) Other parameters and correction targets can be set in the general SD 54760 \$SNS_MEA_FUNCTION_MASK_PIECE.



Machine manufacturer

Please observe the machine manufacturer's instructions.

List of the result parameters

The measuring variant "Rectangular pocket" provides the following result parameters:

Table 2- 19 "Rectangular pocket" result parameters

Parameters	Description	Unit
_OVR [0]	Rectangle length setpoint in the 1st axis of the plane	mm
_OVR [1]	Rectangle length setpoint in the 2nd axis of the plane	mm
_OVR [2]	Rectangle center point setpoint in the 1st axis of the plane	mm
_OVR [3]	Rectangle center point setpoint in the 2nd axis of the plane	mm
_OVR [4]	Rectangle length actual value in the 1st axis of the plane	mm
_OVR [5]	Rectangle length actual value in the 2nd axis of the plane	mm
_OVR [6]	Rectangle center point actual value in the 1st axis of the plane	mm
_OVR [7]	Rectangle center point actual value in the 2nd axis of the plane	mm
_OVR [16]	Rectangle length difference in the 1st axis of the plane	mm
_OVR [17]	Rectangle length difference in the 2nd axis of the plane	mm
_OVR [18]	Rectangle center point difference in the 1st axis of the plane	mm
_OVR [19]	Rectangle center point difference in the 2nd axis of the plane	mm
_OVI [0]	D number or WO number	-
_OVI [2]	Measuring cycle number	-
_OVS_TNAME	Tool name	-

For workpiece measurement with tool offset or correction in the work offset, additional parameters are displayed, see Additional result parameters (Page 265).

2.3.12 Hole - 1 hole (CYCLE977)

Function

This measuring version can be used to measure a hole in a workpiece. The hole diameter is measured as well as the hole center point determined. The measurements are always performed parallel to the geometry axis of the active plane.

With a starting angle, the measuring points can be shifted to the periphery of the hole. A protection zone can be defined in the hole.

With the "3D probe with spindle reversal" measuring method, measurement is performed in the axes of the plane as differential measurement. The special procedure for this measurement permits the use of an uncalibrated multidirectional probe. Probe types 712, 713 and 714 are not suitable for this purpose. A positionable spindle is mandatory.

With the "Align 3D probe" measuring method, the switching direction of the probe is always aligned to the current measuring direction. This function is recommended when high demands are placed on the measuring accuracy. Probe types 712, 713 and 714 are not suitable for this purpose. A positionable spindle is mandatory.

The measurement result (measurement difference) can be used as follows:

- Correction of a ZO so that the workpiece zero point is in relation to the center of the hole.
- Offset of a tool,
- Measurement without offset

Measuring principle

Two opposite points in each of the two geometry axes of the plane are measured. The hole diameter and the center point are calculated from these four measured actual positions, taking into account the calibration values. From the measuring points of the 1st geometry axis of the plane, the center of this axis is calculated and the probe positioned at this center. Starting from this center point, the two points in the 2nd geometry axis are measured, from which the hole diameter is determined. The measurements start in the positive direction of the 1st geometry axis. The measured difference of the hole diameter is used for a tool offset and the position of the hole zero point as basis for a zero offset.

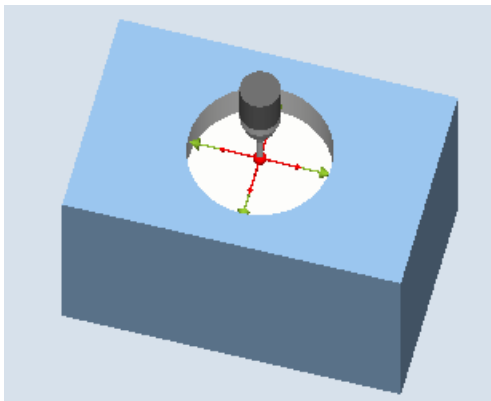

Measure: Hole (CYCLE977)

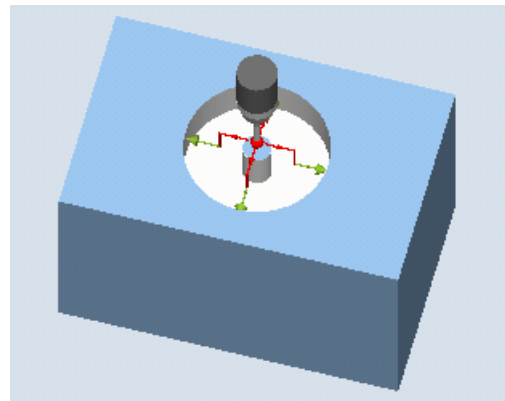

Measure: Hole with protection zone (CYCLE977)

Requirements

- The probe must be active as tool.
- Tool type of the probe:
 - 3D multi probe (type 710)
 - Mono probe (type 712)
 - Star-type probe (type 714)

NOTICE

The following measuring methods are only possible in the axes of the plane:

- 3D probe with spindle reversal (differential measurement)
- Align 3D probe

The probe types 712, 713 and 714 generally **cannot** be used for these measuring methods.

Starting position before the measurement

For a hole (parallel with the axis), without a protection zone, the probe should be positioned with the probe ball center at approximately the center of the hole at the measuring height.

For a protection zone, the probe ball center is positioned approximately centered to the hole at a height above the protection zone. With the infeed path that has been entered, it must be guaranteed that from this height the desired measuring height in the hole can be reached.

NOTICE

If too large a measurement path DFA has been selected so that the protection zone is violated, then the distance is reduced automatically in the cycle. However, there must be sufficient room for the probe ball.

Position after the end of the measuring cycle

Without activated protection zone, the probe ball is at the measuring height in the center of the hole.

With a protection zone, the measuring cycle end position of the probe ball is centered above the hole at the height of the starting position.

NOTICE

The range of the measuring cycle starting points with regard to the hole center point must be within the value of the measuring path DFA, otherwise, there is danger of collision or the measurement cannot be performed!

Procedure

The part program or ShopMill program to be processed has been created and you are in the editor.



1. Press the "Meas. workpiece" softkey.



2. Press the "Hole" softkey.



3. Press the "1 hole" softkey.
The input window "Measure: 1 hole" is opened.

Parameters

G code program			ShopMill program		
Parameter	Description	Unit	Parameter	Description	Unit
Measuring method	<ul style="list-style-type: none"> Standard measuring methods 3D probe with spindle reversal ¹⁾ Align 3D probe²⁾ 	-	T	Name of the probe	-
PL	Measuring plane (G17 - G19)	-	D	Cutting edge number (1 - 9)	-
	Calibration data record (1 - 12) (only for measuring without spindle reversal)	-	Measuring method	<ul style="list-style-type: none"> Standard measuring methods 3D probe with spindle reversal ¹⁾ Align 3D probe²⁾ 	-
				Calibration data record (1 - 12) (only for measuring without spindle reversal)	-
			X	Start point X of the measurement	mm
			Y	Start point Y of the measurement	mm
			Z	Start point Z of the measurement	mm

Parameter	Description	Unit
Correction target	<ul style="list-style-type: none"> Measuring only (no offset) Zero offset (save measured values in a settable ZO) ³⁾ Tool offset (save measured values in the tool data) 	-
TR	Name of tool to be corrected	-
D	Cutting edge number of tool to be corrected	-
∅	Hole diameter setpoint	mm
α0	Angle between measuring axis and workpiece	Degrees
Protection zone	Use protection zone <ul style="list-style-type: none"> Yes No 	-
∅S	Diameter of the protection zone (only for protection zone "Yes")	mm

Parameter	Description	Unit
LS	Length of the protection zone (only for protection zone "Yes")	mm
DX / DY / DZ	Infeed distance at measuring height (only for protection zone "Yes")	mm
DFA	Measurement path	mm
TSA	Safe area for the measurement result	mm
Dimensional tolerance 	Use dimensional tolerance for tool offset <ul style="list-style-type: none"> • Yes • No 	-
TUL	Upper tolerance limit, workpiece (only for dimensional tolerance "Yes")	mm
TLL	Lower tolerance limit, workpiece (only for dimensional tolerance "Yes")	mm

- 1) The "3D probe with spindle reversal" function is shown if bit 16 is set in the general SD 54760 \$SNS_MEA_FUNCTION_MASK_PIECE.
- 2) The "Align 3D probe" function is shown if bit 17 is set in the general SD 54760 \$SNS_MEA_FUNCTION_MASK_PIECE.
- 3) Other parameters and correction targets can be set in the general SD 54760 \$SNS_MEA_FUNCTION_MASK_PIECE.



Machine manufacturer

Please observe the machine manufacturer's instructions.

List of the result parameters

The measuring variant "Hole" provides the following result parameters:

Table 2- 20 "Hole" result parameters

Parameters	Description	Unit
_OVR [0]	Hole diameter setpoint	mm
_OVR [1]	Hole center point setpoint in the 1st axis of the plane	mm
_OVR [2]	Hole center point setpoint in the 2nd axis of the plane	mm
_OVR [4]	Hole diameter actual value	mm
_OVR [5]	Hole center point actual value in the 1st axis of the plane	mm
_OVR [6]	Hole center point actual value in the 2nd axis of the plane	mm
_OVR [16]	Hole diameter difference	mm
_OVR [17]	Hole center point difference in the 1st axis of the plane	mm
_OVR [18]	Hole center point difference in the 2nd axis of the plane	mm
_OVI [0]	D number or WO number	-
_OVI [2]	Measuring cycle number	-
_OVI [3]	Measuring version	-
_OVS_TNAME	Tool name	-

For workpiece measurement with tool offset or correction in the work offset, additional parameters are displayed, see Additional result parameters (Page 265).

2.3.13 Hole - inner circle segment (CYCLE979)

Function

This measuring version can be used to measure a circle segment from the inside. The diameter and the center point of the circle segment in the plane are determined.

With a starting angle, referred to the 1st geometry axis of the plane, the measuring points can be shifted along the circumference of the circle segment. The distance between the measuring points along the circumference is defined using an incremental angle.

With the "3D probe with spindle reversal" measuring method, measurement is performed in the axes of the plane as differential measurement. The special procedure for this measurement permits the use of an uncalibrated multidirectional probe. Probe types 712, 713 and 714 are not suitable for this purpose. A positionable spindle is mandatory.

With the "Align 3D probe" measuring method, the switching direction of the probe is always aligned to the current measuring direction. This function is recommended when high demands are placed on the measuring accuracy. Probe types 712, 713 and 714 are not suitable for this purpose. A positionable spindle is mandatory.

The measurement result (measurement difference) can be used as follows:

- Correction of a ZO so that the workpiece zero point is in relation to the circle segment center point.
- Offset of a tool
- Measurement without offset

Measuring principle

The circle segment can be measured with 3 or 4 measuring points. The intermediate positions to the measuring points are not approached along a circular path parallel to the geometry axis. The distance between the probe ball circumference and the hole corresponds to the measuring path DFA. The direction of the circular path is obtained from the sign of the incremental angle. The measuring path from the intermediate positions to the measuring points is radial to the hole periphery.

The circle segment obtained from the number of measuring points and the incremental angle must not exceed 360 degrees. The measured difference of the segment diameter is used as tool offset, the segment zero as a basis for a zero offset.

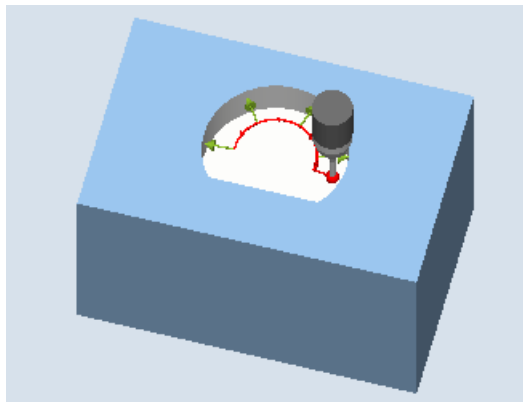

Figure 2-14 Measure: Circle segment inner (CYCLE979), example 4 measuring points

Requirements

- The probe must be active as tool.
- Tool type of the probe:
 - 3D multi probe (type 710)
 - Mono probe (type 712)

NOTICE

The following measuring methods are only possible in the axes of the plane:

- 3D probe with spindle reversal (differential measurement)
- Align 3D probe

The probe types 712, 713 and 714 generally **cannot** be used for these measuring methods.

Note

When measuring circle segments of < 90 degrees, it should be noted that, mathematically speaking, measuring points that deviate from the circular shape exert a particularly great influence on the accuracy of the results (center point, diameter).

For this reason, an especially high degree of care should be taken when measuring small circle segments. Good results can be attained if the following procedures are used:

The circle segment to be measured should be:

- Free from machining residue.
- Have as exact a circular form as possible, guaranteed by the machining technology.
- Have as smooth a surface as possible, guaranteed by the machining technology.
- Measured with high-quality probes, i.e. the shape of the probe ball is as homogeneous as possible.
- Measured with four points (setting via parameters).
- Measured with a recently calibrated probe.

Starting position before the measurement

The probe should be positioned in the 3rd axis of the plane (tool axis) at the required measuring height, approx. at a distance of the measuring path DFA in front of the first measuring point.

Position after the end of the measuring cycle

After measuring, the probe ball circumference is a distance of the measuring path DFA radially from the last measuring point at the measuring height.

NOTICE

The range of the measuring cycle starting points with regard to the circle segment center point must be within the value of the measuring path DFA, otherwise, there is danger of collision or the measurement cannot be performed!

Procedure

The part program or ShopMill program to be processed has been created and you are in the editor.



1. Press the "Meas. workpiece" softkey.



2. Press the "Hole" softkey.

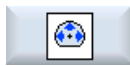

3. Press the "Inner circle segment" softkey.
The input window "Measure: Inner circle segment" is opened.

Parameters

G code program			ShopMill program		
Parameter	Description	Unit	Parameter	Description	Unit
Measuring method	<ul style="list-style-type: none"> Standard measuring methods 3D probe with spindle reversal ¹⁾ Align 3D probe²⁾ 	-	T	Name of the probe	-
PL	Measuring plane (G17 - G19)	-	D	Cutting edge number (1 - 9)	-
	Calibration data record (1 - 12) (only for measuring without spindle reversal)	-	Measuring method	<ul style="list-style-type: none"> Standard measuring methods 3D probe with spindle reversal ¹⁾ Align 3D probe²⁾ 	-
				Calibration data record (1 - 12) (only for measuring without spindle reversal)	-
			X	Start point X of the measurement	mm
			Y	Start point Y of the measurement	mm
			Z	Start point Z of the measurement	mm

Parameter	Description	Unit
Correction target	<ul style="list-style-type: none"> Measuring only (no offset) Zero offset (save measured values in a settable ZO) ³⁾ Tool offset (save measured values in the tool data) 	-
TR	Name of tool to be corrected	-
D	Cutting edge number of tool to be corrected	-
Qty. measuring points	Measurement with: <ul style="list-style-type: none"> 3 points 4 points 	-
∅	Diameter of hole	mm
XM	Center point X (for measuring plane G17)	mm
YM	Center point Y (for measuring plane G17)	mm
α0	Starting angle	Degrees

Parameter	Description	Unit
$\alpha 1$	Incrementing angle	Degrees
DFA	Measurement path	mm
TSA	Safe area for the measurement result	mm
Dimensional tolerance 	Use dimensional tolerance for tool offset <ul style="list-style-type: none"> • Yes • No 	-
TUL	Upper tolerance limit, workpiece (only for dimensional tolerance"Yes")	mm
TLL	Lower tolerance limit, workpiece (only for dimensional tolerance"Yes")	mm

- 1) The "3D probe with spindle reversal" function is shown if bit 16 is set in the general SD 54760 \$SNS_MEA_FUNCTION_MASK_PIECE.
- 2) The "Align 3D probe" function is shown if bit 17 is set in the general SD 54760 \$SNS_MEA_FUNCTION_MASK_PIECE.
- 3) Other parameters and correction targets can be set in the general SD 54760 \$SNS_MEA_FUNCTION_MASK_PIECE.



Machine manufacturer

Please observe the machine manufacturer's instructions.

List of the result parameters

The measuring variant "Inner circle segment" provides the following result parameters:

Table 2- 21 "Inner circle segment" result parameters

Parameters	Description	Unit
_OVR [0]	Hole diameter setpoint	mm
_OVR [1]	Center point setpoint in the 1st axis of the plane	mm
_OVR [2]	Center point setpoint in the 2nd axis of the plane	mm
_OVR [4]	Hole diameter actual value	mm
_OVR [5]	Center point actual value in the 1st axis of the plane	mm
_OVR [6]	Center point actual value in the 2nd axis of the plane	mm
_OVR [16]	Hole diameter difference	mm
_OVR [17]	Center point difference in the 1st axis of the plane	mm
_OVR [18]	Center point difference in the 2nd axis of the plane	mm
_OVI [0]	D number or WO number	-
_OVI [2]	Measuring cycle number	-
_OVI [3]	Measuring version	-
_OVS_TNAME	Tool name	-

For workpiece measurement with tool offset or correction in the work offset, additional parameters are displayed, see Additional result parameters (Page 265).

2.3.14 Spigot - rectangular spigot (CYCLE977)

Function

This measuring version can be used to measure a rectangular spigot on a workpiece. The spigot width and spigot length are measured as well as the spigot center point determined. Measurements are also possible at a rectangular spigot (horizontal) rotated in the working plane. To do this, an angle corresponding to the real spigot position must be entered into the parameterizing screen form. The probing at the sides of the spigot is always at right angles. A protective zone can be defined around the spigot.

With the "3D probe with spindle reversal" measuring method, measurement is performed in the axes of the plane as differential measurement. The special procedure for this measurement permits the use of an uncalibrated multidirectional probe. Probe types 712, 713 and 714 are not suitable for this purpose. A positionable spindle is mandatory.

With the "Align 3D probe" measuring method, the switching direction of the probe is always aligned to the current measuring direction. This function is recommended when high demands are placed on the measuring accuracy. Probe types 712, 713 and 714 are not suitable for this purpose. A positionable spindle is mandatory.

The measurement result (measurement difference) can be used as follows:

- Correction of a ZO so that the workpiece zero point is in relation to the center point of the rectangular spigot.
- Offset of a tool,
- Measurement without offset

Measuring principle

Two opposite points in each of the two geometry axes of the plane are measured. The measurements start in the positive direction of the 1st geometry axis. The spigot width and the spigot length are calculated from the 4 measured actual positions of the spigot sides, taking into account the calibration values. Corresponding to the zero offset selected to be corrected, the position of the spigot center is determined as the workpiece zero. The measuring differences of the side lengths are used as the basic quantity for a tool offset, the position of the spigot zero point as basis for the zero offset.

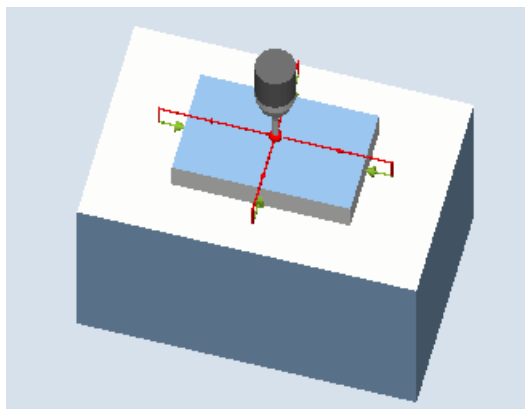

Measure: Rectangular spigot (CYCLE977)

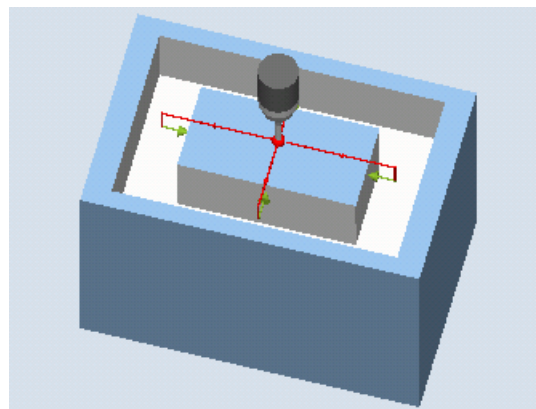

Measure: Rectangular spigot with protection zone (CYCLE977)

Requirements

- The probe must be active as tool.
- Tool type of the probe:
 - 3D multi probe (type 710)
 - Mono probe (type 712)

NOTICE

The following measuring methods are only possible in the axes of the plane:

- 3D probe with spindle reversal (differential measurement)
- Align 3D probe

The probe types 712, 713 and 714 generally **cannot** be used for these measuring methods.

Starting position before the measurement

The probe must be positioned with the probe ball center approximately above the center of the spigot. With the infeed path that has been entered, it must be guaranteed that from this height the desired measuring height at the spigot can be reached.

NOTICE

If too large a measurement path DFA has been selected so that the protection zone is violated, then the distance is reduced automatically in the cycle. However, there must be sufficient room for the probe ball.

Position after the end of the measuring cycle

The measuring cycle end position of the probe ball is centered above the spigot at the height of the measuring cycles starting position.

NOTICE

The range of the cycle starting points with regard to the spigot center point must be within the value of the measuring path DFA, otherwise, there is danger of collision or the measurement cannot be performed!

Procedure

The part program or ShopMill program to be processed has been created and you are in the editor.



1. Press the "Meas. workpiece" softkey.



2. Press the "Spigot" softkey.

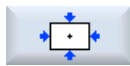

3. Press the "Rectangular spigot" softkey.

The input window "Measure: Rectangular spigot" is opened.

Parameters

G code program			ShopMill program		
Parameter	Description	Unit	Parameter	Description	Unit
Measuring method	<ul style="list-style-type: none"> Standard measuring methods 3D probe with spindle reversal ¹⁾ Align 3D probe²⁾ 	-	T	Name of the probe	-
PL	Measuring plane (G17 - G19)	-	D	Cutting edge number (1 - 9)	-
	Calibration data record (1 - 12) (only for measuring without spindle reversal)	-	Measuring method	<ul style="list-style-type: none"> Standard measuring methods 3D probe with spindle reversal ¹⁾ Align 3D probe²⁾ 	-
				Calibration data record (1 - 12) (only for measuring without spindle reversal)	-
			X	Start point X of the measurement	mm
			Y	Start point Y of the measurement	mm
			Z	Start point Z of the measurement	mm

Parameter	Description	Unit
Correction target	<ul style="list-style-type: none"> Measuring only (no offset) Zero offset (save measured values in a settable ZO) ³⁾ Tool offset (save measured values in the tool data) 	-
TR	Name of tool to be corrected	-
D	Cutting edge number of tool to be corrected	-
W	Setpoint, spigot width	mm
L	Setpoint, spigot length	mm
$\alpha 0$	Angle between measuring axis and workpiece	Degrees
DZ	Infeed distance at measuring height (for G17)	mm
Protection zone	Use protection zone <ul style="list-style-type: none"> Yes No 	-
WS	Width of the protection zone (only for protection zone "Yes")	mm

Parameter	Description	Unit
LS	Length of the protection zone (only for protection zone "Yes")	mm
DFA	Measurement path	mm
TSA	Safe area for the measurement result	mm
Dimensional tolerance 	Use dimensional tolerance for tool offset <ul style="list-style-type: none"> • Yes • No 	-
TUL	Upper tolerance limit, workpiece (only for dimensional tolerance"Yes")	mm
TLL	Lower tolerance limit, workpiece (only for dimensional tolerance"Yes")	mm

- 1) The "3D probe with spindle reversal" function is shown if bit 16 is set in the general SD 54760 \$SNS_MEA_FUNCTION_MASK_PIECE.
- 2) The "Align 3D probe" function is shown if bit 17 is set in the general SD 54760 \$SNS_MEA_FUNCTION_MASK_PIECE.
- 3) Other parameters and correction targets can be set in the general SD 54760 \$SNS_MEA_FUNCTION_MASK_PIECE.



Machine manufacturer

Please observe the machine manufacturer's instructions.

List of the result parameters

The measuring variant "Rectangular spigot" provides the following result parameters:

Table 2- 22 "Rectangular spigot" result parameters

Parameters	Description	Unit
_OVR [0]	Rectangle length setpoint in the 1st axis of the plane	mm
_OVR [1]	Rectangle length setpoint in the 2nd axis of the plane	mm
_OVR [2]	Rectangle center point setpoint in the 1st axis of the plane	mm
_OVR [3]	Rectangle center point setpoint in the 2nd axis of the plane	mm
_OVR [4]	Rectangle length actual value in the 1st axis of the plane	mm
_OVR [5]	Rectangle length actual value in the 2nd axis of the plane	mm
_OVR [6]	Rectangle center point actual value in the 1st axis of the plane	mm
_OVR [7]	Rectangle center point actual value in the 2nd axis of the plane	mm
_OVR [16]	Rectangle length difference in the 1st axis of the plane	mm
_OVR [17]	Rectangle length difference in the 2nd axis of the plane	mm
_OVR [18]	Rectangle center point difference in the 1st axis of the plane	mm
_OVR [19]	Rectangle center point difference in the 2nd axis of the plane	mm
_OVI [0]	D number or WO number	-
_OVI [2]	Measuring cycle number	-
_OVI [3]	Measuring version	-
_OVS_TNAME	Tool name	-

For workpiece measurement with tool offset or correction in the work offset, additional parameters are displayed, see Additional result parameters (Page 265).

2.3.15 Spigot - 1 circular spigot (CYCLE977)

Function

This measuring version can be used to measure a circular spigot on a workpiece.

The spigot diameter is measured and the spigot center point is determined. The measurements are always performed parallel to the geometry axis of the active plane.

With a starting angle, the measuring points can be shifted along the circumference of the spigot. A protective zone can be defined around the spigot.

With the "3D probe with spindle reversal" measuring method, measurement is performed in the axes of the plane as differential measurement. The special procedure for this measurement permits the use of an uncalibrated multidirectional probe. Probe types 712, 713 and 714 are not suitable for this purpose. A positionable spindle is mandatory.

With the "Align 3D probe" measuring method, the switching direction of the probe is always aligned to the current measuring direction. This function is recommended when high demands are placed on the measuring accuracy. Probe types 712, 713 and 714 are not suitable for this purpose. A positionable spindle is mandatory.

The measurement result (measurement difference) can be used as follows:

- Correction of a ZO so that the zero point is in relation to the center point of the spigot.
- Offset of a tool
- Measurement without offset

Measuring principle

Two opposite points in each of the two geometry axes of the plane are measured. The spigot diameter and the center point are calculated from these 4 measured actual positions, taking into account the calibration values. From the measuring points of the 1st geometry axis of the plane, the center of this axis is calculated and the probe positioned at this center.

Starting from this center point, the two points in the 2nd geometry axis are measured, from which the actual spigot diameter is determined. The measurements start in the positive direction of the 1st geometry axis. The measured difference of the spigot diameter is used as tool offset and the position of the spigot zero point as basis for a zero offset.

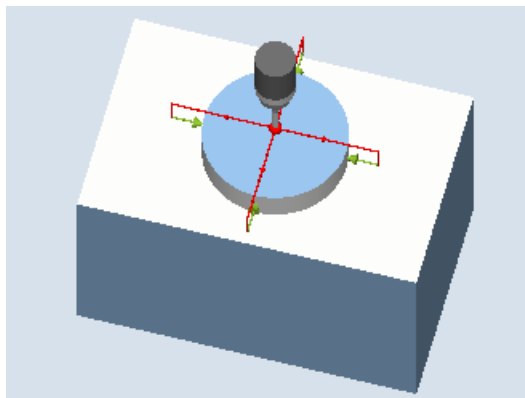

Measure: Circular spigot (CYCLE977)

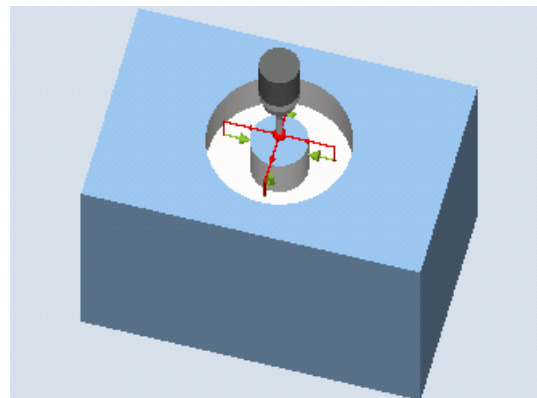

Measure: Circular spigot with protection zone (CYCLE977)

Requirements

- The probe must be active as tool.
- Tool type of the probe:
 - 3D multi probe (type 710)
 - Mono probe (type 712)

NOTICE

The following measuring methods are only possible in the axes of the plane:

- 3D probe with spindle reversal (differential measurement)
- Align 3D probe

The probe types 712, 713 and 714 generally **cannot** be used for these measuring methods.

Starting position before the measurement

The probe must be positioned with the probe ball center approximately above the center of the spigot. With the infeed path that has been entered, it must be guaranteed that from this height the desired measuring height at the spigot can be reached.

NOTICE

If too large a measurement path DFA has been selected so that the protection zone is violated, then the distance is reduced automatically in the cycle. However, there must be sufficient room for the probe ball.

Position after the end of the measuring cycle

The measuring cycle end position of the probe ball is centered above the spigot at the height of the measuring cycles starting position.

NOTICE

The range of the measuring cycle starting points with regard to the spigot center point must be within the value of the measuring path DFA, otherwise, there is danger of collision or the measurement cannot be performed!

Procedure

The part program or ShopMill program to be processed has been created and you are in the editor.



1. Press the "Meas. workpiece" softkey.



2. Press the "Spigot" softkey.

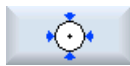

3. Press the "1 circular spigot" softkey.
The input window "Measure: 1 circular spigot" is opened.

Parameters

G code program			ShopMill program		
Parameter	Description	Unit	Parameter	Description	Unit
Measuring method	<ul style="list-style-type: none"> Standard measuring methods 3D probe with spindle reversal ¹⁾ Align 3D probe²⁾ 	-	T	Name of the probe	-
PL	Measuring plane (G17 - G19)	-	D	Cutting edge number (1 - 9)	-
	Calibration data record (1 - 12) (only for measuring without spindle reversal)	-	Measuring method	<ul style="list-style-type: none"> Standard measuring methods 3D probe with spindle reversal ¹⁾ Align 3D probe²⁾ 	-
				Calibration data record (1 - 12) (only for measuring without spindle reversal)	-
			X	Start point X of the measurement	mm
			Y	Start point Y of the measurement	mm
			Z	Start point Z of the measurement	mm

Parameter	Description	Unit
Correction target	<ul style="list-style-type: none"> Measuring only (no offset) Zero offset (save measured values in a settable ZO) ³⁾ Tool offset (save measured values in the tool data) 	-
TR	Name of tool to be corrected	-
D	Cutting edge number of tool to be corrected	-
∅	Spigot diameter setpoint	mm
α0	Angle between measuring axis and workpiece	Degrees
DZ	Infeed distance at measuring height (for G17)	mm
Protection zone	Use protection zone <ul style="list-style-type: none"> Yes No 	-
∅S	Diameter of the protection zone (only for protection zone "Yes")	mm

Parameter	Description	Unit
DFA	Measurement path	mm
TSA	Safe area for the measurement result	mm
Dimensional tolerance 	Use dimensional tolerance for tool offset <ul style="list-style-type: none"> • Yes • No 	-
TUL	Upper tolerance limit, workpiece (only for dimensional tolerance"Yes")	mm
TLL	Lower tolerance limit, workpiece (only for dimensional tolerance"Yes")	mm

- 1) The "3D probe with spindle reversal" function is shown if bit 16 is set in the general SD 54760 \$SNS_MEA_FUNCTION_MASK_PIECE.
- 2) The "Align 3D probe" function is shown if bit 17 is set in the general SD 54760 \$SNS_MEA_FUNCTION_MASK_PIECE.
- 3) Other parameters and correction targets can be set in the general SD 54760 \$SNS_MEA_FUNCTION_MASK_PIECE.



Machine manufacturer

Please observe the machine manufacturer's instructions.

List of the result parameters

The measuring variant "1 circular spigot" provides the following result parameters:

Table 2- 23 "1 circular spigot" result parameters

Parameters	Description	Unit
_OVR [0]	Circular spigot diameter setpoint	mm
_OVR [1]	Circular spigot center point setpoint in the 1st axis of the plane	mm
_OVR [2]	Circular spigot center point setpoint in the 2nd axis of the plane	mm
_OVR [4]	Circular spigot diameter actual value	mm
_OVR [5]	Circular spigot center point actual value in the 1st axis of the plane	mm
_OVR [6]	Circular spigot center point actual value in the 2nd axis of the plane	mm
_OVR [16]	Circular spigot diameter difference	mm
_OVR [17]	Circular spigot center point difference in the 1st axis of the plane	mm
_OVR [18]	Circular spigot center point difference in the 2nd axis of the plane	mm
_OVI [0]	D number or WO number	-
_OVI [2]	Measuring cycle number	-
_OVI [3]	Measuring version	-
_OVS_TNAME	Tool name	-

For workpiece measurement with tool offset or correction in the work offset, additional parameters are displayed, see Additional result parameters (Page 265).

2.3.16 Spigot - outer circle segment (CYCLE979)

Function

This measuring version can be used to measure circle segment from the outside. The diameter and the center point of the circle segment in the plane are determined. With a starting angle, referred to the 1st geometry axis of the plane, the measuring points can be shifted along the circumference of the circle segment. The distance between the measuring points along the circumference is defined using an incremental angle.

With the "3D probe with spindle reversal" measuring method, measurement is performed in the axes of the plane as differential measurement. The special procedure for this measurement permits the use of an uncalibrated multidirectional probe. Probe types 712, 713 and 714 are not suitable for this purpose. A positionable spindle is mandatory.

With the "Align 3D probe" measuring method, the switching direction of the probe is always aligned to the current measuring direction. This function is recommended when high demands are placed on the measuring accuracy. Probe types 712, 713 and 714 are not suitable for this purpose. A positionable spindle is mandatory.

The measurement result (measurement difference) can be used as follows:

- Correction of a ZO so that the workpiece zero point is in relation to the circle segment center point.
- Offset of a tool
- Measurement without offset

Measuring principle

The circle segment can be measured with three or four measuring points. The intermediate positions to the measuring points are not approached along a circular path parallel to the geometry axis. The distance between the probe ball circumference and the hole corresponds to the measuring path DFA. The direction of the circular path is obtained from the sign of the incremental angle. The measuring path from the intermediate positions to the measuring points is radial to the hole periphery.

The circle segment obtained from the number of measuring points and the incremental angle must not exceed 360 degrees. The measured difference of the segment diameter is used as tool offset, the segment zero point as a basis for a zero offset.

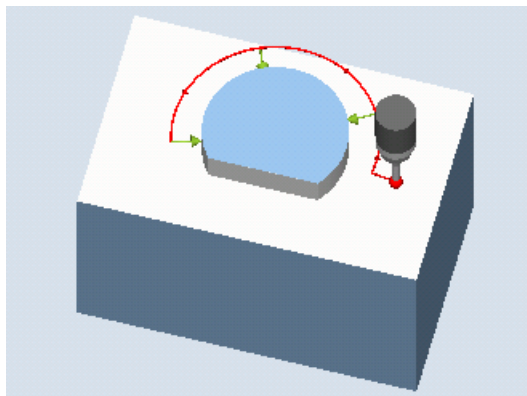

Figure 2-15 Measure: Outer circle segment (CYCLE977)

Requirements

- The probe must be active as tool.
- Tool type of the probe:
 - 3D multi probe (type 710)
 - Mono probe (type 712)

NOTICE

The following measuring methods are only possible in the axes of the plane:

- 3D probe with spindle reversal (differential measurement)
- Align 3D probe

The probe types 712, 713 and 714 generally **cannot** be used for these measuring methods.

Note

When measuring circle segments of < 90 degrees, it should be noted that, mathematically speaking, measuring points that deviate from the circular shape exert a particularly great influence on the accuracy of the results (center point, diameter).

For this reason, an especially high degree of care should be taken when measuring small circle segments. Good results can be attained if the following procedures are used:

The circle segment to be measured should be:

- Free from machining residue.
- Have as exact a circular form as possible, guaranteed by the machining technology.
- Have as smooth a surface as possible, guaranteed by the machining technology.
- Measured with high-quality probes, i.e. the shape of the probe ball is as homogeneous as possible.
- Measured with four points (setting via parameters).
- Measured with a recently calibrated probe.

Starting position before the measurement

The probe should be positioned in the 3rd axis of the plane (tool axis) at the required measuring height, approx. at a distance of the measuring path DFA in front of the first measuring point.

Position after the end of the measuring cycle

At the end of the measurement, the probe ball circumference is a distance of the measuring path DFA radially from the last measuring point at the measuring height.

NOTICE

The range of the measuring cycle starting points with regard to the circle segment center point must be within the value of the measuring path DFA, otherwise, there is danger of collision or the measurement cannot be performed!

Procedure

The part program or ShopMill program to be processed has been created and you are in the editor.



1. Press the "Meas. workpiece" softkey.



2. Press the "Spigot" softkey.



3. Press the "Outer circle segment" softkey.
The input window "Measure: Outer circle segment" is opened.

Parameters

G code program			ShopMill program		
Parameter	Description	Unit	Parameter	Description	Unit
Measuring method	<ul style="list-style-type: none"> Standard measuring methods 3D probe with spindle reversal ¹⁾ Align 3D probe²⁾ 	-	T	Name of the probe	-
PL	Measuring plane (G17 - G19)	-	D	Cutting edge number (1 - 9)	-
	Calibration data record (1 - 12) (only for measuring without spindle reversal)	-	Measuring method	<ul style="list-style-type: none"> Standard measuring methods 3D probe with spindle reversal ¹⁾ Align 3D probe²⁾ 	-
				Calibration data record (1 - 12) (only for measuring without spindle reversal)	-
			X	Start point X of the measurement	mm
			Y	Start point Y of the measurement	mm
			Z	Start point Z of the measurement	mm

Parameter	Description	Unit
Correction target	<ul style="list-style-type: none"> Measuring only (no offset) Zero offset (save measured values in a settable ZO) ³⁾ Tool offset (save measured values in the tool data) 	-
TR	Name of tool to be corrected	-
D	Cutting edge number of tool to be corrected	-
Qty. measuring points	Measurement with: <ul style="list-style-type: none"> 3 points 4 points 	-
∅	Diameter of spigot	mm
XM	Center point X (for measuring plane G17)	mm
YM	Center point Y (for measuring plane G17)	mm
α0	Starting angle	Degrees

Parameter	Description	Unit
$\alpha 1$	Incrementing angle	Degrees
DFA	Measurement path	mm
TSA	Safe area for the measurement result	mm
Dimensional tolerance 	Use dimensional tolerance for tool offset <ul style="list-style-type: none"> • Yes • No 	-
TUL	Upper tolerance limit, workpiece (only for dimensional tolerance"Yes")	mm
TLL	Lower tolerance limit, workpiece (only for dimensional tolerance"Yes")	mm

- 1) The "3D probe with spindle reversal" function is shown if bit 16 is set in the general SD 54760 \$SNS_MEA_FUNCTION_MASK_PIECE.
- 2) The "Align 3D probe" function is shown if bit 17 is set in the general SD 54760 \$SNS_MEA_FUNCTION_MASK_PIECE.
- 3) Other parameters and correction targets can be set in the general SD 54760 \$SNS_MEA_FUNCTION_MASK_PIECE.



Machine manufacturer

Please observe the machine manufacturer's instructions.

List of the result parameters

The measuring variant "Outer circle segment" provides the following result parameters:

Table 2- 24 "Outer circle segment" result parameters

Parameters	Description	Unit
_OVR [0]	Circle segment diameter setpoint	mm
_OVR [1]	Center point setpoint in the 1st axis of the plane	mm
_OVR [2]	Center point setpoint in the 2nd axis of the plane	mm
_OVR [4]	Circle segment diameter actual value	mm
_OVR [5]	Center point actual value in the 1st axis of the plane	mm
_OVR [6]	Center point actual value in the 2nd axis of the plane	mm
_OVR [16]	Circle segment diameter difference	mm
_OVR [17]	Center point difference in the 1st axis of the plane	mm
_OVR [18]	Center point difference in the 2nd axis of the plane	mm
_OVI [0]	D number or WO number	-
_OVI [2]	Measuring cycle number	-
_OVI [3]	Measuring version	-
_OVS_TNAME	Tool name	-

For workpiece measurement with tool offset or correction in the work offset, additional parameters are displayed, see Additional result parameters (Page 265).

2.3.17 3D - align plane (CYCLE998)

Function

This measuring variant can be used to determine and correct the angular position of a three-dimensional inclined plane on a workpiece by measuring three points. The angles are in relation to the rotation around the axes of the active plane G17 to G19.

The same requirements as for the simple angle measurement apply, see measuring version Align edge (Page 101).

Additional data are required for the setpoint input of the 2nd angle. A correction is made in the zero offset in the rotary components (rotation) of the specified zero offset (ZO).

The translatory components of the ZO remain unchanged, and should be corrected in a subsequent measurement (e.g. set edge, corner).

After the measurement, at suitable machines where orientation transformation (swiveling, TRAORI) is set up, the probe can be aligned perpendicular on the measuring plane (machining plane).

- Swiveling: See the Programming Manual *SINUMERIK 840D sl/840D/840Di sl cycles*, Chapter "Swiveling - CYCLE800".

- TRAORI

G0 C3=1 ;align to tool axis Z for G17

Measuring principle

The "Align plane" measuring variant is performed according to the 2-angle measurement principle:

The angular offsets are in the rotary part of the geometry axes for a workpiece with a three-dimensional inclined plane.

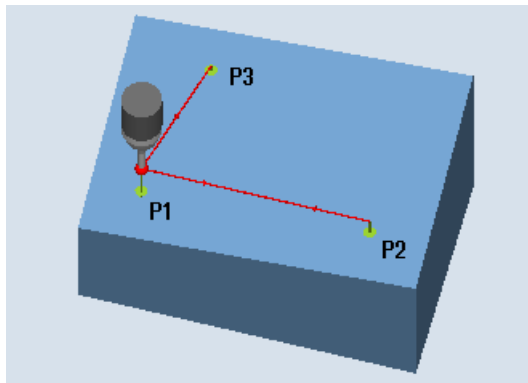

Figure 2-16 Measure: Align plane (CYCLE998)

Note

Maximum measured angle

The `CYCLE998` measuring cycle is capable of measuring a maximum angle of -45 ... +45 degrees.

Requirements

- The probe must be called as a tool with a tool length compensation.
- Tool type of the probe:
 - 3D multi probe (type 710)
 - Mono probe (type 712)

Starting position before the measurement

The probe is pre-positioned over the 1st measuring point P1 in the axes of the plane (for G17: XY).

Positioning taking into account a protection zone

- Protection zone "no"

The probe is positioned in the measuring axis as a maximum at the distance of measurement path DFA above the surface to be measured above measuring point P1 at the measuring height.
- Protection zone "yes"

The measuring probe is positioned in the measuring axis as a maximum at the distance of measurement path DFA and the amount in parameter **DZ** (for G17 always measuring axis Z) above the surface to be measured above measuring point P1 at the measuring height.

In both cases, when making the measurement, measuring point P1 must be able to be safely reached.

For the 1st measurement, if the distances from the reference surface are selected to be too large, then a measurement is not made.

Measuring axis is always the 3rd axis of the plane (for G17: Z). Measuring point P1 should be selected in the plane so that the distance to the 2nd measuring point (L2) and to the 3rd measuring point (L3) results in positive values.

Positioning between measuring points P1, P2, P3

Intermediate positioning "parallel to the plane"

The probe traverses parallel to the reference surface at the distance of parameter L2 to measuring point P2, or after the 2nd measurement at the distance of parameter L3, to measuring point P3. In so doing, the angle from parameters α and **TSA** is taken into account. **TSA** contains the value for the maximum permissible angular deviation.

After performing the measurement in P1, the probe is positioned to P2 in the 1st axis of the plane and in the 3rd axis of the plane (for G17 in X and Z) taking into account the angle β and a maximum deviation in **TSA**. After the measurement in P2 has been performed the probe is repositioned to P1 along the same path. The probe is positioned from P1 to P3 in the 2nd axis of the plane (for G17 in X and Y) and the 3rd axis of the plane taking into account angle α and maximum deviation in **TSA** and then a measurement performed.

Intermediate positioning "parallel to the axis"

Positioning from P1 to P2 is performed in the 1st axis of the plane, from P1 to P3 in the 2nd axis of the plane. With the starting position P1 in the 3rd axis of the plane (for G17 in Z), P2 and/or P3 must also be able to be reached without any collision.

Position after the end of the measuring cycle

The probe is at a distance of the measurement path above the last measuring point (P3).

Procedure

The part program or ShopMill program to be processed has been created and you are in the editor.



1. Press the "Meas. workpiece" softkey.



2. Press the "3D" softkey.



3. Press the "Align plane" softkey.

The input window "Measure: Align plane" is opened.

Parameters

G code program			ShopMill program		
Parameters	Description	Unit	Parameters	Description	Unit
PL	Measuring plane (G17 - G19)	-	T	Name of the probe	-
	Calibration data set (1 - 12)	-	D	Cutting edge number (1 - 9)	-
				Calibration data set (1 - 12)	-
			X	Start point X of the measurement	mm
			Y	Start point Y of the measurement	mm
			Z	Start point Z of the measurement	mm

Parameters	Description	Unit
Correction target	<ul style="list-style-type: none"> Measuring only (no offset) Work offset (save measured values in an adjustable WO) ¹⁾ 	-
Positioning	Position probe: <ul style="list-style-type: none"> Parallel to the axis Parallel to the plane 	-
α	Inclination of the plane to the X axis (X for G17)	Degrees
L2X	Distance to the 2nd measuring point in the direction of the X axis	mm
β	Inclination of the plane to the Y axis (Y for G17)	Degrees
L3X	Distance to the 3rd measuring point in the direction of the X axis	mm

Parameters	Description	Unit
L3Y	Distance to the 3rd measuring point in the direction of the Y axis	mm
Protection zone 	Use protection zone <ul style="list-style-type: none"> • Yes • No 	-
DZ (only for protection zone "Yes")	Infeed path at the measuring height in the Z axis (for G17)	mm
DFA	Measurement path	mm
TSA	Safe area for the measurement result	mm

1) Other parameters and correction targets can be set in the general SD 54760\$SNS_MEA_FUNCTION_MASK_PIECE.



Machine manufacturer

Please observe the machine manufacturer's instructions.

List of the result parameters

The measuring variant "Align plane" provides the following result parameters:

Table 2- 25 "Align plane" result parameters

Parameters	Description	Unit
_OVR [0]	Angle setpoint between workpiece surface and 1st axis of the plane of the active WCS	Degrees
_OVR [1]	Angle setpoint between workpiece surface and 2nd axis of the plane of the active WCS	Degrees
_OVR [4]	Angle actual value between workpiece surface and 1st axis of the plane of the active WCS	Degrees
_OVR [5]	Angle actual value between workpiece surface and 2nd axis of the plane of the active WCS	Degrees
_OVR [16]	Angle difference around the 1st axis of the plane	Degrees
_OVR [17]	Angle difference around the 2nd axis of the plane	Degrees
_OVR [20]	Angle offset value	Degrees
_OVR [21]	Angle offset value around the 1st axis of the plane	Degrees
_OVR [22]	Angle offset value around the 2nd axis of the plane	Degrees
_OVR [23]	Angle offset value around the 3rd axis of the plane	Degrees
_OVR [28]	Safe area	Degrees
_OVR [30]	Empirical value	Degrees
_OVI [0]	WO number	-
_OVI [2]	Measuring cycle number	-
_OVI [5]	Probe number	-
_OVI [7]	Empirical value memory number	-
_OVI [9]	Alarm number	-
_OVI [11]	Status offset request	-

2.3.18 3D - sphere (CYCLE997)

Function

This measuring variant can be used to measure a ball. Measuring can be parallel to the axis or on a circular path in the workpiece coordinate system.

The center point (position of the ball) for a known diameter is determined from three or four measuring points at the circumference and one measuring point at the "north pole" of the ball. With the selection "determine ball diameter", using an additional measurement, the ball diameter is correctly determined.

Measuring cycle CYCLE997 can measure the ball and, in addition, automatically correct a zero offset (ZO) in the translational offsets of the three axes of the active plane on the basis of the position of the ball center.

Measuring principle

The following description refers to the machining plane G17:

- Axes of the plane: XY
- Tool axis: Z

Beginning at the starting position, the setpoint of the ball equator is approached initially in -X and then in -Z. Three or four points are measured at this measuring height.

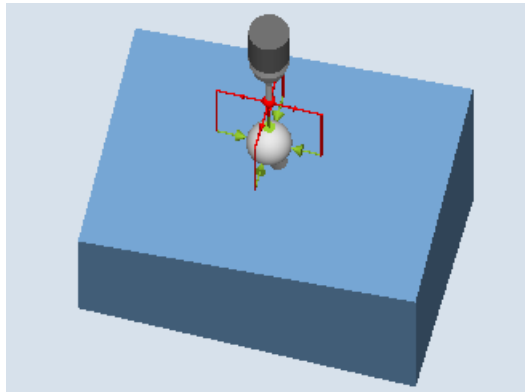

Measure: Ball (CYCLE997),
Example of "paraxial" positioning

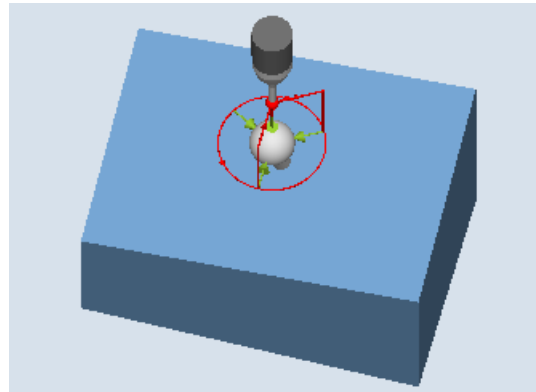

Measure: Ball (CYCLE997),
Example of positioning "on a circular path"

- Measuring version, "Paraxial" positioning:

When positioning between measuring points (e.g. P1-> P2, P2->P3), the axis always retracts to the starting position (at the north pole of the ball).

- Measuring version, positioning "on a circular path":

Positioning between measuring points (e.g. P1-> P2, P2->P3) is realized on a circular path at the same height as the equator of the ball.

With probe angle α_0 (starting angle), the angular position when the measuring point P1 is defined; with α_1 the incremental angle to P2 and further to P3 – and for the measuring version with 4 measuring points, to P4.

The sum of starting angle α_0 and all incremental angles α_1 must not exceed 360 degrees! An angular range of ± 360 degrees permitted for the starting angle.

Internally, the actual center point of circle XY is determined from these measured values (ball center in the plane). Then with +Z and in XY, the axis traverses to the calculated "north pole" of the ball. A measurement is made there in -Z.

The complete center point of the ball is calculated in the three axes of the plane (XYZ) from the measuring points.

In the case of a repeat measurement, the axis traverses to the precise equator of the ball (from the 1st measurement); this improves the measurement result.

If, in addition to the ball center point, also the actual ball diameter is to be measured, then the cycle performs a supplementary measurement parallel with the axis at the equator in the +X direction.

The "Positioning on a circular path" measuring version should be preferably used, because this permits optimum positioning behavior. In addition, with this measuring version, when circling around the ball, the probe can be aligned in the switching direction (see the "align probe" parameter).

Correction in a zero offset (ZO)

The set-actual differences of the center point coordinates are calculated in the translatory part of the ZO. During the correction, the determined ball center point includes the specified setpoint position (workpiece coordinates, three axes) in the corrected ZO.

Requirements

- The probe must be called as a tool with tool length compensation and be active.
- Tool type of the probe: 3D multi probe (type 710)
- The ball diameter must be significantly greater than the ball diameter of the probe stylus.

Starting position before the measurement

The probe must be positioned above the set ball center point at a safe height.

The measuring cycle generates the traversing motion for approaching the measuring points itself and performs the measurements depending on the measuring version selected.

Note

The ball to be measured must be mounted in such a way that when positioning the probe, the equator of the probe ball of the measuring object can be reliably reached in the workpiece coordinate system and no collision with the ball clamping occurs. By specifying a variable starting and incremental angle, when positioning on a circular path, this is also possible under difficult clamping conditions.

The measurement path in parameter DFA should be selected so large that all measuring points can be reached within total measurement path 2 DFA. Otherwise no measurement can be performed or the measurements are incomplete.

Position after the end of the measuring cycle

The probe is above the determined ball center point at a safe height (height at the starting position).

Procedure

The part program or ShopMill program to be processed has been created and you are in the editor.



1. Press the "Meas. workpiece" softkey.



2. Press the "3D" softkey.

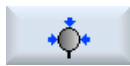

3. Press the "Sphere" softkey.
The input window "Measure: Sphere" is opened.

Parameters

G code program			ShopMill program		
Parameters	Description	Unit	Parameters	Description	Unit
PL	Measuring plane (G17 - G19)	-	T	Name of the probe	-
	Calibration data set (1 - 12)	-	D	Cutting edge number (1 - 9)	-
				Calibration data set (1 - 12)	-
			X	Start point X of the measurement	mm
			Y	Start point Y of the measurement	mm
			Z	Start point Z of the measurement	mm

Parameters	Description	Unit
Correction target	<ul style="list-style-type: none"> Measuring only (no offset) Work offset (save measured values in an adjustable WO) ¹⁾ 	-
Positioning	Traverse around sphere: <ul style="list-style-type: none"> Parallel to the axis On circular path 	-
Only for positioning "On circular path":		
Align probe	Always align probe in the same contact direction <ul style="list-style-type: none"> No Yes 	-
Number of measuring points	Measuring the ball with 3 or 4 measuring points at the ball equator	-
Repeat measurement	Repeat measurement with determined values <ul style="list-style-type: none"> No Yes 	-
Determining the ball diameter	<ul style="list-style-type: none"> No Yes 	-

Parameters	Description	Unit
∅	Sphere diameter setpoint	mm
α0	Contact angle (only for positioning "On circular path")	Degrees
α1	Incremental angle (only for positioning "On circular path")	Degrees
XM	Center point of the ball on the X axis (for G17)	mm
YM	Center point of the sphere on the Y axis	mm
ZM	Center point of the sphere on the Z axis	mm
DFA	Measurement path	mm
TSA	Safe area for the measurement result	mm

1) Other parameters and correction targets can be set in the general SD 54760\$SNS_MEA_FUNCTION_MASK_PIECE .



Machine manufacturer

Please observe the machine manufacturer's instructions.

List of the result parameters

The measuring variant "Sphere" provides the following result parameters:

Table 2- 26 "Sphere" result parameters

Parameters	Description	Unit
_OVR[0]	Sphere diameter setpoint	mm
_OVR[1]	Center point coordinate setpoint in the 1st axis of the plane	mm
_OVR[2]	Center point coordinate setpoint in the 2nd axis of the plane	mm
_OVR[3]	Center point coordinate setpoint in the 3rd axis of the plane	mm
_OVR[4]	Sphere diameter actual value	mm
_OVR[5]	Center point coordinate actual value in the 1st axis of the plane	mm
_OVR[6]	Center point coordinate actual value in the 2nd axis of the plane	mm
_OVR[7]	Center point coordinate actual value in the 3rd axis of the plane	mm
_OVR[8]	Sphere diameter difference	mm
_OVR[9]	Center point coordinate difference in the 1st axis of the plane	mm
_OVR[10]	Center point coordinate difference in the 2nd axis of the plane	mm
_OVR[11]	Center point coordinate difference in the 3rd axis of the plane	mm
_OVR[28]	Safe area	mm
_OVI[0]	WO number	-
_OVI[2]	Measuring cycle number	-
_OVI[5]	Probe number	-
_OVI[9]	Alarm number	-
_OVI[11]	Status offset request	-
_OVI[12]	Supplementary error data for alarm, internal measurement evaluation	-

2.3.19 3D - 3 spheres (CYCLE997)

Function

This measuring variant can be used to measure three balls of equal size, fixed to a common base (workpiece).

Measuring individual balls is realized the same as when measuring one ball, see 3D ball (CYCLE997) (Page 152).

After measuring the 3rd ball, for a correction in a zero offset (ZO), the position of the workpiece, on which the balls are mounted, is corrected as a rotation in the ZO.

Measuring principle

The position of the center points of the three balls should be entered as a setpoint in parameters XM1 to ZM3 in the active workpiece coordinate system. The measurement begins with the 1st ball and ends with the 3rd ball.

Positioning between the balls is realized along a straight line at the height of the starting position of the 1st ball. The parameter settings – such as the number of measuring points, determining the diameter, diameter, apply to all three balls.

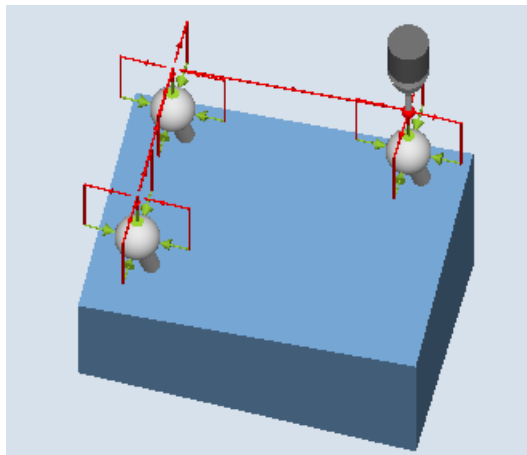

Measure: 3 balls (CYCLE997),
Example of "paraxial positioning"

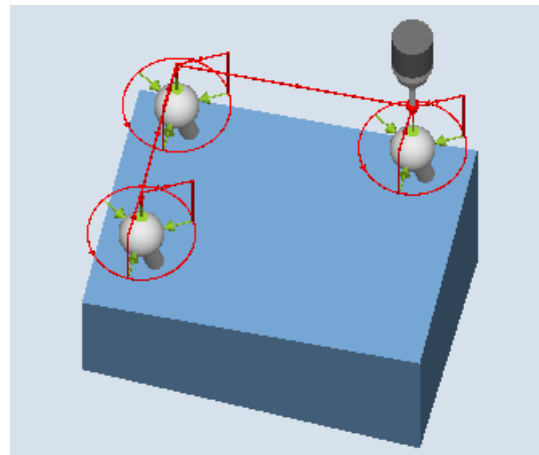

Measure: 3 balls (CYCLE997),
Example of "positioning on a circular path"

Correcting the zero offset (ZO)

After the measurement of the 3rd ball, a zero offset is calculated from the measured center points of the balls. This consists of translatory components (offset) and rotary components (rotation), and describes the position of the workpiece, on which the balls are mounted.

During the correction, the triangle of the determined ball center points includes the specified center point setpoint position (workpiece coordinates). The sum of the deviations of the balls to each other (distortion of the triangle) must be within the value of parameter TVL.

Otherwise no correction is performed and an alarm is output.

Requirements

- The probe must be called as a tool with tool length compensation and be active.
- Tool type of the probe: 3D multi probe (type 710)
- In the active ZO, the approximate values for the position of the balls regarding offset and rotation are entered and activated. The value in the offset of the ZO refers to the 1st ball.
- Only minor deviations from the actual position of workpiece from the cycle can be expected.
- The ball diameter must be significantly greater than the ball diameter of the probe stylus.

Starting position before the measurement

The probe must be positioned above the setpoint ball center point of the 1st ball at a safe height.

Note

The measuring points must be selected so that there is no danger of a collision with a ball fixture or another obstacle during measuring or intermediate positioning.

The measurement path in parameter DFA should be selected so large that all measuring points can be reached within total measurement path 2 DFA. Otherwise no measurement can be performed or the measurements are incomplete.

Position after the end of the measuring cycle

The probe is above the determined ball center point of the 3rd ball at a safe height (height at the starting position).

Procedure

The part program or ShopMill program to be processed has been created and you are in the editor.



1. Press the "Meas. workpiece" softkey.









2. Press the "3D" softkey.









3. Press the "3 spheres" softkey.

The input window "Measure: 3 spheres" is opened.

Parameters

G code program			ShopMill program		
Parameters	Description	Unit	Parameters	Description	Unit
PL 	Measuring plane (G17 - G19)	-	T	Name of the probe	-
 	Calibration data set (1 - 12)	-	D 	Cutting edge number (1 - 9)	-
			 	Calibration data set (1 - 12)	-
			X	Start point X of the measurement	mm
			Y	Start point Y of the measurement	mm
			Z	Start point Z of the measurement	mm

Parameters	Description	Unit
Correction target 	<ul style="list-style-type: none"> Measuring only (no offset) Work offset (save measured values in an adjustable WO) ¹⁾ 	-
Positioning 	Traverse around sphere: <ul style="list-style-type: none"> Parallel to the axis On circular path 	-
Only for positioning "On circular path":		
Align probe 	Always align probe in the same contact direction <ul style="list-style-type: none"> Yes No 	-
Qty. measuring points 	Measuring the balls with 3 or 4 measuring points at the equator of the balls	-
Repeat measurement 	Repeat measurement with determined values <ul style="list-style-type: none"> Yes No 	-
Determining the ball diameter 	<ul style="list-style-type: none"> Yes No 	-
∅	Sphere diameter setpoint	mm
α0	Contact angle (only for positioning "On circular path")	Degrees
α1	Incremental angle (only for positioning "On circular path")	Degrees
XM1	Center point of the 1st sphere X axis	mm
YM1	Center point of the 1st sphere Y axis	mm
ZM1	Center point of the 1st sphere Z axis	mm
XM2	Center point of the 2nd sphere X axis	mm
YM2	Center point of the 2nd sphere Y axis	mm
ZM2	Center point of the 2nd sphere Z axis	mm
XM3	Center point of the 3rd sphere X axis	mm
YM3	Center point of the 3rd sphere Y axis	mm
ZM3	Center point of the 3rd sphere Z axis	mm

Parameters	Description	Unit
TVL	Limit value for the distortion of the resulting triangle from the 3 measured center points of the balls	-
DFA	Measurement path	mm
TSA	Safe area for the measurement result	mm

1) Other parameters and correction targets can be set in the general SD 54760\$SNS_MEA_FUNCTION_MASK_PIECE .



Machine manufacturer

Please observe the machine manufacturer's instructions.

List of the result parameters

The measuring variant "3 spheres" provides the following result parameters:

Table 2- 27 "3 spheres" result parameters

Parameters	Description	Unit
_OVR[0]	Sphere diameter setpoint of 1st sphere	mm
_OVR[1]	Center point coordinate setpoint in the 1st axis of the plane of the 1st sphere	mm
_OVR[2]	Center point coordinate setpoint in the 2nd axis of the plane of the 1st sphere	mm
_OVR[3]	Center point coordinate setpoint in the 3rd axis of the plane of the 1st sphere	mm
_OVR[4]	Sphere diameter actual value of 1st sphere	mm
_OVR[5]	Center point coordinate actual value in the 1st axis of the plane of the 1st sphere	mm
_OVR[6]	Center point coordinate actual value in the 2nd axis of the plane of the 1st sphere	mm
_OVR[7]	Center point coordinate actual value in the 3rd axis of the plane of the 1st sphere	mm
_OVR[8]	Sphere diameter difference of the 1st sphere	mm
_OVR[9]	Center point coordinate difference in the 1st axis of the plane of the 1st sphere	mm
_OVR[10]	Center point coordinate difference in the 2nd axis of the plane of the 1st sphere	mm
_OVR[11]	Center point coordinate difference in the 3rd axis of the plane of the 1st sphere	mm
_OVR[12]	Sphere diameter actual value of 2nd sphere	mm
_OVR[13]	Center point coordinate actual value in the 1st axis of the plane of the 2nd sphere	mm
_OVR[14]	Center point coordinate actual value in the 2nd axis of the plane of the 2nd sphere	mm
_OVR[15]	Center point coordinate actual value in the 3rd axis of the plane of the 2nd sphere	mm
_OVR[16]	Sphere diameter difference of the 2nd sphere	mm
_OVR[17]	Center point coordinate difference in the 1st axis of the plane of the 2nd sphere	mm
_OVR[18]	Center point coordinate difference in the 2nd axis of the plane of the 2nd sphere	mm
_OVR[19]	Center point coordinate difference in the 3rd axis of the plane of the 2nd sphere	mm
_OVR[20]	Sphere diameter actual value of 3rd sphere	mm
_OVR[21]	Center point coordinate actual value in the 1st axis of the plane of the 3rd sphere	mm

Parameters	Description	Unit
_OVR[22]	Center point coordinate actual value in the 2nd axis of the plane of the 3rd sphere	mm
_OVR[23]	Center point coordinate actual value in the 3rd axis of the plane of the 3rd sphere	mm
_OVR[24]	Sphere diameter difference of the 3rd sphere	mm
_OVR[25]	Center point coordinate difference in the 1st axis of the plane of the 3rd sphere	mm
_OVR[26]	Center point coordinate difference in the 2nd axis of the plane of the 3rd sphere	mm
_OVR[27]	Center point coordinate difference in the 3rd axis of the plane of the 3rd sphere	mm
_OVR[28]	Safe area	mm
_OVI[0]	WO number	-
_OVI[2]	Measuring cycle number	-
_OVI[5]	Probe number	-
_OVI[9]	Alarm number	-
_OVI[11]	Status offset request	-
_OVI[12]	Supplementary error data for alarm, internal measurement evaluation	-

2.3.20 3D - angular deviation spindle (CYCLE995)

Function

The cycle CYCLE995 is based on the Renishaw AxiSet™ method based on the patent application, WO 2007068912 A1. It is recommended to use the Renishaw probe with maximum accuracy for the application of the CYCLE995.

With this measuring version the angularity of a spindle to the machine tool is measured on a calibration ball. The measurement is carried out by combining the measuring versions "sphere" (CYCLE997) and "outer circle segment" (CYCLE979).

Based on the measured values, the angular deviation of the spindle to the axis of the plane calculated.

With the measured angular deviations, the spindle can be mechanically aligned parallel to the tool axis or the corresponding tables for sag compensation can be updated.

If there are rotary axes, the determined angular data can be used to align the rotary axis. To do this, the result parameter (`_OVR`) of CYCLE995 must be used.

Measuring principle

The 1st measurement of the calibration ball is performed with CYCLE997 and measurement is repeated. The starting angle can be freely selected. The incremental angle between the measuring points should be set to 90 degrees. From 2 measuring points along the circumference and one measuring point at the "north pole" of the sphere (highest point), the center point (position of the ball) is determined. In addition, the diameter of the calibration ball can be determined.

The 2nd measurement is realized with CYCLE979 at the shaft of the probe at the distance of DZ. The starting angle and the incremental angle are taken from the 1st measurement. The measuring path and the safe area are also from the 1st measurement times a factor of 1.5. The center point of the probe shaft in the plane is determined.

For both measurements, the switching direction of the probe is corrected for each individual measurement.

The angular deviation in XY is calculated from the results of the two center points in XY and the distance between the two measurements in Z (for G17).

The tolerance parameter of the angular values is optionally checked (dimensional tolerance "yes").

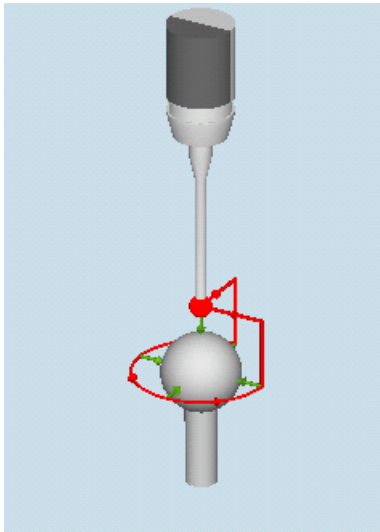

Measure: Angular deviation, spindle (CYCLE995), 1st measurement

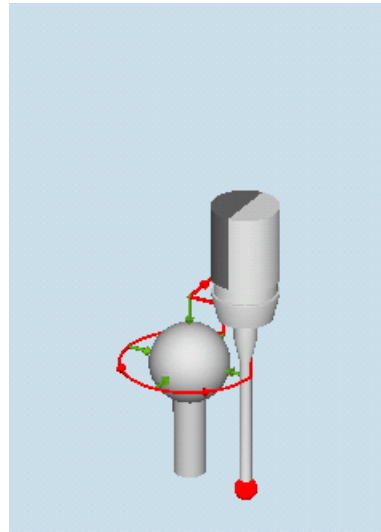

Measure: Angular deviation, spindle (CYCLE995), 2nd measurement

Preconditions

- The precision of the calibration ball should be better than 0.001 mm.
- An electronic program is loaded into the spindle with the longest possible stylus tip (>100 mm).
- The probe shaft should have a good surface quality (e.g. ground steel shaft).

Starting position before the measurement

Before the cycle is called, the probe must be positioned at the distance of the measuring path (DFA) above the mounted calibration ball (North Pole) so that this can be approached without any collisions at the circumference (equator).

Position after the end of the measuring cycle

The probe is located after the measuring cycle at the start position. In the probe direction (for G17 Z), the probe is at the distance of the measuring path (DFA) above the north pole.

Procedure

The part program to be executed has been created and you are in the editor.



1. Press the "Meas. workpiece" softkey.







2. Press the "3D" softkey.



3. Press the "Spindle angular displacement" softkey.

The "Measure: Spindle Angular Displacement" input window opens.

Parameters

G code program		
Parameter	Description	Unit
PL 	Measuring plane (G17 - G19)	-
 	Calibration data record (1 - 12)	-
Det. ball diam. 	Determining the ball diameter <ul style="list-style-type: none"> No Yes 	-
∅	Ball diameter	mm
α0	Contact angle	Degrees
DZ	Depth infeed for 2nd measurement	mm
DFA	Measurement path	mm
TSA	Safe area for the measurement result	mm
Dimensional tolerance 	Use dimensional tolerance <ul style="list-style-type: none"> Yes No 	-
TUL	Upper tolerance limit, workpiece (only for dimensional tolerance"Yes")	mm

1) Other parameters and correction targets can be set in the general SD 54760\$SNS_MEA_FUNCTION_MASK_PIECE.



Machine manufacturer

Please observe the machine manufacturer's instructions.

List of the result parameters

The measuring variant "machine geometry" provides the following result parameters:

Table 2- 28 Result parameter "Machine geometry" (CYCLE995)

Parameters	Description	Unit
_OVR [2]	Actual angle between X and Z (X = 1st axis of the plane for G17, Z = 3rd axis of the plane for G17)	Degrees
_OVR [3]	Actual angle between Y and Z (Y = 2nd axis of the plane for G17)	Degrees
_OVR [4]	Distance in Z between the probe ball and measuring position at the probe shaft	mm
_OVR [5]	Exceeding the tolerance between X and Z (for dimensional tolerance "Yes")	mm
_OVR [6]	Exceeding the tolerance between Y and Z (for dimensional tolerance "Yes")	mm
_OVR [7]	Spindle camber in XZ (XZ for G17)	mm
_OVR [8]	Spindle camber in YZ (YZ for G17)	mm
_OVR [9]	Upper tolerance limit of the measured angle values (_OVR[2], _OVR[3])	mm
_OVI [2]	Measuring cycle number	-
_OVI [3]	Measuring version	-
_OVI [5]	Number, probe calibration data field	-
_OVI [9]	Alarm number	-

2.3 Measure workpiece (milling)

Table 2- 29 Intermediate results 1st measurement (calibration ball)

Parameters	Description	Unit
_OVR [10]	Setpoint calibration ball	mm
_OVR [11]	Setpoint center point coordinate, 1st axis of the plane	mm
_OVR [12]	Setpoint center point coordinate, 2nd axis of the plane	mm
_OVR [13]	Setpoint center point coordinate, 3rd axis of the plane	mm
_OVR [14]	Actual ball diameter	mm
_OVR [15]	Actual value center point coordinate, 1st axis of the plane	mm
_OVR [16]	Actual value center point coordinate, 2nd axis of the plane	mm
_OVR [17]	Actual value center point coordinate, 3rd axis of the plane	mm
_OVR [18]	Ball diameter difference	mm
_OVR [19]	Difference center point coordinate, 1st axis of the plane	mm
_OVR [20]	Difference center point coordinate, 2nd axis of the plane	mm
_OVR [21]	Difference center point coordinate, 3rd axis of the plane	mm

Table 2- 30 Intermediate results 2nd measurement (measuring probe shaft or 2nd probe ball at the shaft)

Parameters	Description	Unit
_OVR [22]	Setpoint calibration ball diameter	mm
_OVR [23]	Center point setpoint in the 1st axis of the plane	mm
_OVR [24]	Center point setpoint in the 2nd axis of the plane	mm
_OVR [25]	Center point actual value in the 1st axis of the plane	degrees
_OVR [26]	Center point actual value in the 2nd axis of the plane	degrees
_OVR [27]	Center point difference in the 1st axis of the plane	Degrees
_OVR [28]	Center point difference in the 2nd axis of the plane	degrees

2.3.21 3D - kinematics (CYCLE996)

Function

With the "Measure kinematics" measuring version (CYCLE996), it is possible to calculate the geometric vectors used to define the kinematic 5-axis transformation (TRAORI and TCARR) by measuring the position of the ball in space.

The measurement is essentially carried out by means of workpiece probes, which scan three positions of a measuring ball on each rotary axis. The ball positions can be defined in accordance with user specifications so that they correspond to the geometric ratios on the machine. The only way of setting the ball positions is to reposition the rotary axis that is to be measured in each case.

Aside from the basic mechanics of the machine, no specific knowledge is required to use CYCLE996. No dimension drawings or machine location diagrams are necessary to carry out measuring.

References: /PGZ/ Programming Manual *SINUMERIK 840D sl/840D/840Di sl Cycles*, CYCLE800.

Possible fields of application

The measuring version "Measure kinematics" can be used to determine transformation-relevant data for kinematic transformations that contain rotary axes (TRAORI, TCARR).

- Redetermination of swivel data records
 - Machine start-up
 - Use of swivel-mounted workholders as TCARR
- Check of swivel data records
 - Service following collisions
 - Checking the kinematics during the machining process

Kinematics with manual axes (manually adjustable rotary tables, swivel-mounted workholders) can be measured in the same way as kinematics with NC-controlled rotary axes.

When starting CYCLE996 a swivel data record must be parameterized with the basic data (kinematic type, see the Programming Manual *SINUMERIK 840D sl/840D/840Di sl Cycles*, CYCLE800). The measurement itself must be carried out without an active kinematic transformation.

Requirements

The following requirements must be met in order to use CYCLE996 (Measure kinematics):

- Workpiece probe is calibrated
- Calibration ball is mounted
- Oriented tool carrier has been set-up (general MD 18088:
\$MN_MM_NUM_TOOL_CARRIER > 0)
- The basic geometry of the machine (X, Y, Z) is rectangular and referenced

- The right angle refers to the workpiece spindle and should be preferably checked using a test mandrel
- Defined position of the rotary axes involved in the transformation
- Defined traverse directions in compliance with the standard of all axes involved in the transformation according to ISO 841-2001 and/or DIN 66217 (right-hand rule)

Measuring principle

The "Measure kinematics" measuring variant always requires the following procedure:

1. Measure a rotary axis (Page 165)
2. Measure a second rotary axis (if this exists)
3. Calculate the swivel data records (calculate kinematics) (Page 165)
4. The calculated data is activated automatically or with the aid of the user

The user (preferably the machine manufacturer) should ensure compliance with the specified sequence.

If the position of the calibration ball within the machine can be specified as an inherent part of the design, then it will be possible to store the entire kinematic measurement process (carried out using CYCLE996) as a part program, which is extremely advantageous. As a result, the user can carry out measurement of the kinematics under a set of predefined conditions at any given point in time.

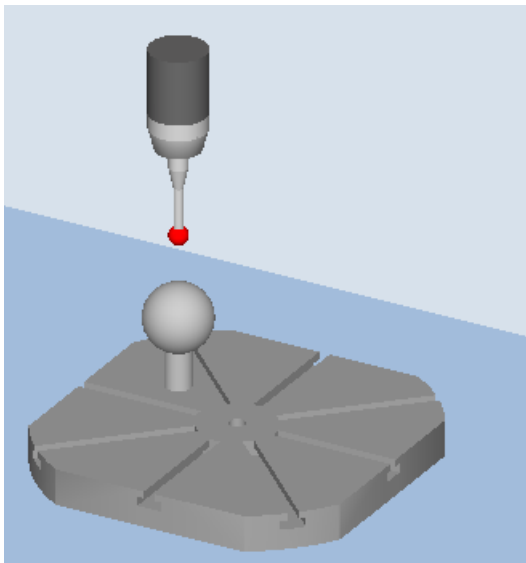

Measure: Kinematic (CYCLE996),
1st measurement, swivel table

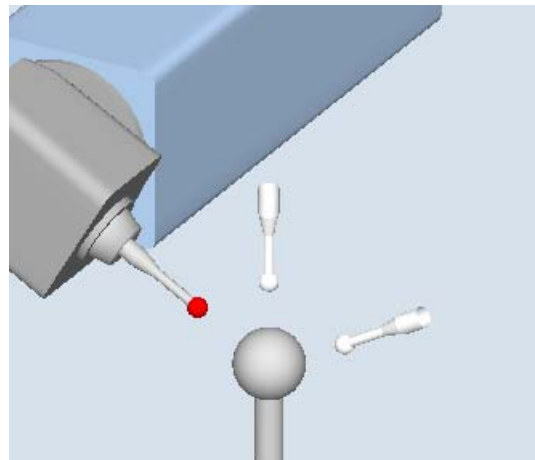

Measure: Kinematic (CYCLE996),
3rd measurement, swivel head

Measuring kinematics

Starting from the kinematics initial state, the relevant rotary axes are measured individually.

- Rotary axes 1 or 2 can be measured in any order. If the machine kinematics only have one rotary axis, this is measured as rotary axis 1. During the measurement procedure, no 5-axis transformations (TCARR or TRAORI) are active.
- The basic data for the kinematics are always the data of the tool carrier with orientation capability. If a dynamic 5-axis transformation is to be supported, it is preferable to use transformation type 72 (vectors from TCARR data).
- The linear and rotary axes must be repositioned at starting positions P1 to P3 before measuring cycle `CYCLE996` is called in the NC program. The starting position is automatically accepted in `CYCLE996` as the position setpoint for the "Measure ball" function.
- In each of the ball (rotary axis) positions selected, measuring is performed in accordance with the parameters and by calling `CYCLE996`.
- The kinematics are calculated using a separate, parameterized call of `CYCLE996`.
- When the 3rd measurement has been completed, the results of the measurement and the `CYCLE996` setting "Calculate kinematics" are written to the result parameter `_OVR[]`. When the "Enter vectors" function is selected (refer to `S_MVAR`, `S_TC`), then data is output to the swivel data record that has been set-up (TCARR, TRAORI(1)).
- A protocol file with the measurement results in an appropriate data format (machine data or TCARR data) can be optionally output.

Input screen forms "kinematics"

`CYCLE996` has to be called three times in order to complete the entire measuring and vector calculation process for one rotary axis. Between cycle calls, the user must reposition the rotary axis to be measured. Any rotary axis that is not being measured must not be repositioned during the measurement procedure. The linear axes are positioned at the starting positions P1, P2, P3.

Using the respective softkeys, the 1st up to the 3rd measurement are called.

At the end of the 3rd measurement, a call calculates the vectors of the measured rotary axis. The requirement for this is that 1st to 3rd measurements have been carried out for the rotary axis concerned, and that the corresponding measurement results (center points of the calibration ball) have been saved. The vectors of the machine kinematics are then calculated in full when both rotary axes have been measured. The measurement counter, parameter `_OVR[40]`, is displayed in the result bit or in the protocol.

Measurement for kinematics with swivel head:

1st measurement P1 (initial state) 2nd measurement P2 3rd measurement P3

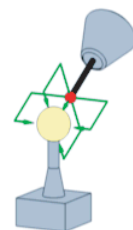
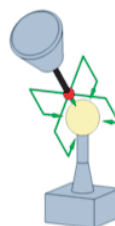

2.3 Measure workpiece (milling)

With the 2nd and 3rd measurements, the rotary axis to be measured is rotated around the largest possible angle. The position of the calibration ball must be stationary during the measurements.

Note

Measure kinematics is also possible with active 5-axis transformation (TRAORI). Requirements for this are roughly set vectors of the 5-axis transformation. The positions for measuring the kinematics are approached in the user program with active transformation. During the actual measurement with the calibration ball, `CYCLE996` switches off the transformation and switches it on again after the measurement.

Starting position before the measurement

A rotary axis is measured by calling `CYCLE996` three times (measurements 1 to 3).

The probe ball must be able to reach the equator of the calibration ball. The 1st measurement must take place in the kinematics normal position. If a rotary axis rotates parallel to the spindle without offset in a head kinematics (fork head), the 1st measurement can be made with applied probe. The rotary axis that is not to be measured is not in the initial position of the kinematics.

The starting position of the probe must be approached by the user or from the user program (see example program). The probe must be prepositioned in the direction of the tool orientation (ORI) above the highest point of the calibration ball (probe aligned with ball center point). After approaching the starting position, the distance (D) from the calibration ball should be as short as possible.

Position after the end of the measuring cycle

After each measurement (1 to 3) of a rotary axis, the probe is located above the calibration ball at a maximum distance of the measurement path DFA.

Measuring an individual rotary axis

The following steps must be carried out in order to measure a rotary axis:

- Mount the calibration ball on the machine table (user)
- Define and approach the three ball positions with the rotary axis that is to be measured (user)
- Specify and approach the three ball positions with the probe in a linear movement/in linear movements (user)
- Using `CYCLE996`, scan all three ball positions of the calibration ball with the probe.

Mounting the calibration ball

In the case of machinery, the calibration ball is to be installed on the machine table.

In order to measure kinematics for swivel-mounted workholders, the ball must be incorporated into the appropriate workholder. In all cases it must be ensured that the probe can approach and bypass the mounted calibration ball without collision in all the selected rotary axis positions.

Considering the need to avoid collisions, the calibration ball should be mounted as far as possible from the center of rotation of the rotary axis that is to be measured.

If the three ball positions result in too small a triangle, this will negatively affect the accuracy of the procedure:

Calibration ball mounted sufficiently far from the center of rotation; large triangle can be clamped

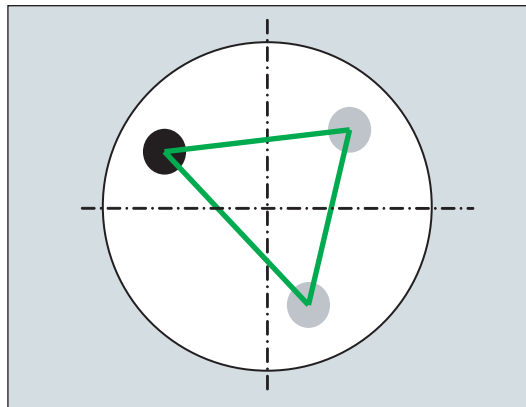

Calibration ball mounted too near the center of rotation; clamped triangle is too small

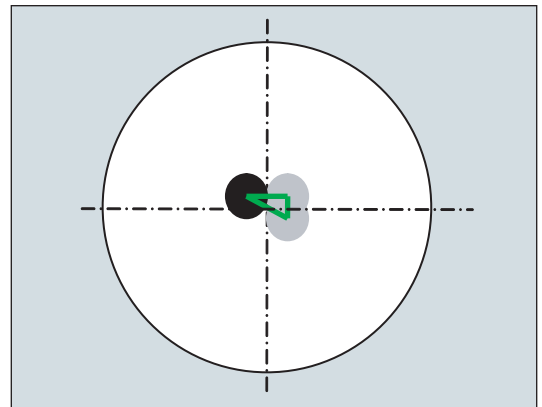

Note

While measuring a rotary axis, the mechanical hold-down of the calibration ball must not be altered. It is only with table and mixed kinematics that different calibration ball mounting positions are permissible for the purpose of measuring the first and subsequent rotary axes.

Defining the rotary axis positions

Three measuring positions (ball position) must be defined for each rotary axis. Please note that the positions of the ball in space (resulting from the three defined rotary axis positions) should lead to as large a triangle as possible being clamped.

Rotary axis positions sufficiently far away from one another; large triangle clamped

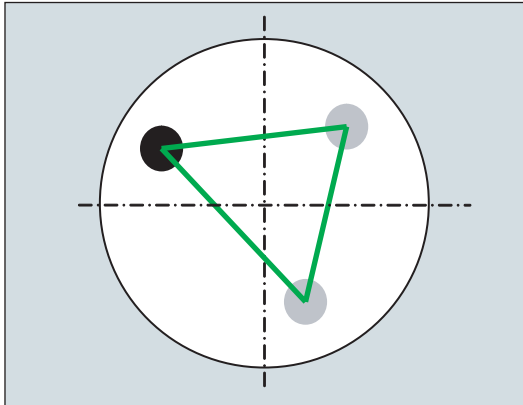

Rotary axis positions poorly selected; clamped triangle is too small

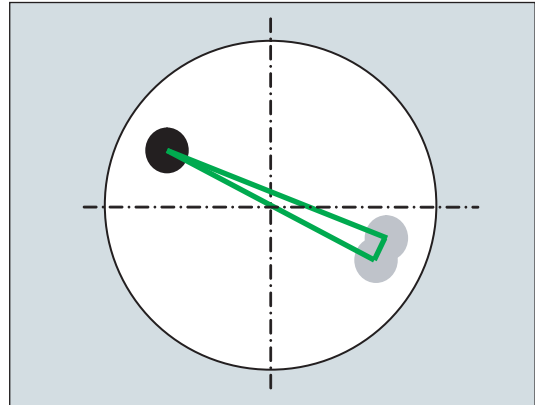

The calculated angle of the angle segment of the rotary axis is monitored in the **TVL** parameter. Angle values of < 20 degrees can cause inaccuracies when calculating the kinematics.

Approaching the ball position

First of all, the probe must be positioned above the calibration ball at each of the three rotary axis positions defined by the user. The position must only be approached by traversing the linear axes (X, Y, Z). The positions themselves must be entered (set up) by the user. They should be determined manually using an active probe.

When selecting approach positions, please bear in mind that, within the context of automatic calibration ball scanning, the probe always moves in its preferred direction. Particularly where head and mixed kinematics are concerned, the starting point should be selected in a way that ensures alignment of the probe with the center point of the calibration ball in the approach position.

Starting point selected directly above the calibration ball

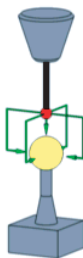

Starting point selected laterally above the calibration ball

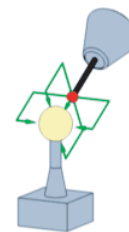

Note

If the machine does not proceed as expected when the calibration ball is being scanned, the basic orientation and travel direction of the rotary axes should be checked (has DIN conformity been maintained when defining the axes?)

Starting position

The probe must be repositioned in the direction of the tool orientation (ORI) above the highest point of the calibration ball (probe aligned with ball center point). The distance (A) to the calibration ball after approaching the starting position should correspond to the measuring path parameter (DFA).

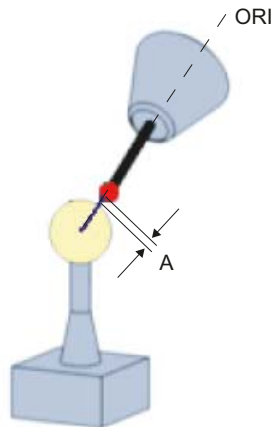

Figure 2-17 Starting position

Note

Measure kinematics is also possible with active 5-axis transformation (TRAORI).

As a requirement for measuring the kinematics with active TRAORI, the vectors of the 5-axis transformation must be roughly set. The positions for measuring the kinematics are approached in the user program with active transformation. During the actual measurement with the calibration ball, CYCLE996 switches off the transformation and switches it on again after the measurement.

Measuring an individual ball position

Once the probe has been positioned in accordance with user specifications above the ball, either manually or by the part program (starting point of CYCLE996), the calibration ball is scanned by calling CYCLE996 and the current ball position is measured.

To this end, the user should parameterize and call CYCLE996 separately for each ball position.

Calculating and activating the swivel data sets

After measuring the three ball positions that are required in each case for all the relevant rotary axes, the entire set of swivel data sets can be calculated by means of CYCLE996. CYCLE996 should be parameterized and called for this purpose.

Correction target

In the "Calculate kinematics" screen form, in the "offset target" field, for the vectors it can be set as to whether "only" a calculation should be made (only measuring) or whether the calculated vectors should be saved in the swivel data set. Before saving, the user can decide whether the calculated swivel data set should be displayed and changed. If the calculated swivel data set should not be displayed, the user can decide whether the swivel data set should be immediately overwritten. In all other cases, before saving the swivel data set, the operator is prompted to make a selection.

Table 2- 31 Display options in the "Calculate kinematics" screen form

Parameters	Measuring only		Swivel data set	
	Yes	No	No	Yes
Display data set	Yes	No	No	Yes
Data set can be edited	-	-	-	Yes/no
Confirm the change	-	-	Yes/no	-

- entry field is not displayed

In addition, the swivel data set can be saved as protocol file ("save data set").

The protocol file is saved in the actual NC data path (or workpiece) in which the measurement program is running. The file name corresponds to the name of the swivel data set, and is generated with a count index "_M1" to "_M99".

The protocol file contains the syntax of the parameters of the swivel data set of the NC function TCARR, e.g. :

```
$TC_CARR1[1]=-426.708853 $TC_CARR2[1]=-855.050806 ... ;!xyz.
```

If a transformation type <> 72 is set in the machine data for the dynamic transformation (TRAORI), the calculated vectors are saved in the protocol file also as machine data.

Tolerance limits

Activating tolerance limits when parameterizing CYCLE996 (compare output values and calculated values), allows conclusions to be drawn as regards unusual changes in the mechanical kinematic chain. The unintentional automatic overwriting of output values can be avoided by adjusting the tolerance limits.

 CAUTION
<p>The rotary axis vectors V1/V2 (orientation of the rotary axes) are never automatically overwritten.</p>

Primarily, the calculated rotary axis vectors enable an assessment to be made regarding the mechanical desired/actual state of the kinematics. Depending on the kinematics configuration, even the smallest and corrected deviations in the position of the rotary axis vectors can result in large compensating movements.

Procedure

The part program to be executed has been created and you are in the editor.



1. Press the "Meas. workpiece" softkey.



2. Press the "3D" softkey.



3. Press the "Kinematics" softkey.

The input window "Measure: Kinematic" is opened.

You can then open the following input windows via the following softkeys:



1. (see Parameters of 1st to 3rd measurement (Page 165))
Measurement



2. Measurement



3. Measurement











Calculate (see Calculate parameters (Page 165))

Parameters of 1st to 3rd measurement

G code program		
Parameters	Description	Unit
PL	Measuring plane (G17 - G19)	-
	Calibration data set (1 - 12)	-
Positioning	Traverse around sphere: <ul style="list-style-type: none"> • Parallel to the axis • On circular path 	-
Align probe (only for positioning "On circular path")	Always align probe in the same contact direction: <ul style="list-style-type: none"> • Yes • No 	-
Rotary axis 1	Name of rotary axis 1 of the swivel data set	-
Rotary axis angle 1	Rotary axis angle during the measurement ¹⁾	Degrees
Rotary axis 2	Name of rotary axis 2 of the swivel data set	-
Rotary axis angle 2	Rotary axis angle during the measurement ¹⁾	Degrees
∅	Sphere diameter	mm
α0	Starting angle (only for "positioning on circular path")	Degrees
DFA	Measurement path	mm
TSA	Safe area for the measurement result	mm

¹⁾ Only for manual or semi-automatic rotary axis of the swivel data set

Calculate parameters

G code program				
Parameters	Description			Unit
PL 	Measuring plane (G17 - G19)			-
Correction target 	Only measuring (only calculate vectors)	Swivel data set (calculate vectors and save to swivel data set)		-
Display data set 	Yes/No	No	Yes	-
Data set can be changed 	-	-	Yes/No	-
Confirm the change 	-	Yes/No	-	-
Save data set	Data set is saved in a protocol file			
Rotary axis 1	Name of rotary axis 1 of the swivel data set			-
Normalizing 	<ul style="list-style-type: none"> No (without normalizing) X (normalizing in direction X) Y (normalizing in direction Y) Z (normalizing in direction Z) 			-
Value input	Position value for normalizing			mm
Rotary axis 2	Name of rotary axis 2 of the swivel data set			-
Normalizing 	<ul style="list-style-type: none"> No (without normalizing) X (normalizing in direction X) Y (normalizing in direction Y) Z (normalizing in direction Z) 			-
Value input	Position value for normalizing			mm
Tolerance 	Use dimensional tolerance <ul style="list-style-type: none"> Yes No 			-
TLIN	Max. tolerance of the offset vectors (only for tolerance "Yes")			mm
TROT	Max. tolerance of the rotary axis vectors (only for tolerance "Yes")			Degrees
TVL	Limit value for distortion of the triangle			Degrees
Close vector chain 	<ul style="list-style-type: none"> Yes No 			-

- entry field is not displayed

List of the result parameters

The measuring variant "calculate kinematics" provides the following result parameters:

Table 2- 32 "Calculate kinematics" result parameters

Parameters	Description	Unit
_OVR[1]	Offset vector I1 \$TC_CARR1[n] X component	mm
_OVR[2]	Offset vector I1 \$TC_CARR2[n] Y component	mm
_OVR[3]	Offset vector I1 \$TC_CARR3[n] Z component	mm
_OVR[4]	Offset vector I2 \$TC_CARR4[n] X component	mm
_OVR[5]	Offset vector I2 \$TC_CARR5[n] Y component	mm
_OVR[6]	Offset vector I2 \$TC_CARR6[n] Z component	mm
_OVR[7]	Rotary axis vector V1 \$TC_CARR7[n] X component	mm
_OVR[8]	Rotary axis vector V1 \$TC_CARR8[n] Y component	mm
_OVR[9]	Rotary axis vector V1 \$TC_CARR9[n] Z component	mm
_OVR[10]	Rotary axis vector V2 \$TC_CARR10[n] X component	mm
_OVR[11]	Rotary axis vector V2 \$TC_CARR11[n] Y component	mm
_OVR[12]	Rotary axis vector V2 \$TC_CARR12[n] Z component	mm
_OVR[15]	Offset vector I3 \$TC_CARR15[n] X component	mm
_OVR[16]	Offset vector I3 \$TC_CARR16[n] Y component	mm
_OVR[17]	Offset vector I3 \$TC_CARR17[n] Z component	mm
_OVR[18]	Offset vector I4 \$TC_CARR18[n] X component	mm
_OVR[19]	Offset vector I4 \$TC_CARR19[n] Y component	mm
_OVR[20]	Offset vector I4 \$TC_CARR20[n] Z component	mm
_OVI[2]	Measuring cycle number	-
OVI[3]	Measuring variant (s{MVAR})	-
OVI[8]	Number of swivel data record (s{TC})	-
_OVI[9]	Alarm number	-

The measurement results (calculated vectors) depend on the type of kinematics

Kinematics type		Measuring result
Head kinematics ¹⁾		
I1 \$TC_CARR1...3[n]	Corresponds to	_OVR[1]..._OVR[3]
I2 \$TC_CARR4...6[n]		_OVR[4]..._OVR[6]
I3 \$TC_CARR15...17[n]		_OVR[15]..._OVR[17]
		_OVR[18]..._OVR[20] = 0
Table kinematics ²⁾		
I2 \$TC_CARR4...6[n]	Corresponds to	_OVR[4]..._OVR[6]
I3 \$TC_CARR15...17[n]		_OVR[15]..._OVR[17]
I4 \$TC_CARR18...20[n]		_OVR[18]..._OVR[20]
		_OVR[1]..._OVR[3] = 0

Kinematics type		Measuring result
Mixed kinematics ³⁾		
I1 \$TC_CARR1...3[n]	Corresponds to	_OVR[1]..._OVR[3]
I2 \$TC_CARR4...6[n]		_OVR[4]..._OVR[6]
I3 \$TC_CARR15...17[n]		_OVR[15]..._OVR[17]
I4 \$TC_CARR18...20[n]		_OVR[18]..._OVR[20]

The result parameters that are not calculated = 0

- 1) Close vector chain $I1=-(I3+I2)$; for fixed-mounted machine kinematics
- 2) Close vector chain $I4=-(I3+I2)$; for fixed-mounted machine kinematics
- 3) Close vector chain $I1=-I2$ $I4=-I3$; for fixed-mounted machine kinematics

Table 2- 33 Intermediate results _OVR[32] to _OVR[71]

Parameters	Description	Unit
_OVR[32,33,34] ¹⁾	Linear vectors of 1st rotary axis are not normalized	mm
_OVR[35,36,37] ¹⁾	Linear vectors of 2nd rotary axis are not normalized	mm
_OVR[40] ²⁾	Measurement counter x0 = 1st measurement of 1st rotary axis started x1 = 1st measurement of 1st rotary axis is OK x2 = 2nd measurement of 1st rotary axis is OK x3 = 3rd measurement of 1st rotary axis is OK 0x = 1st measurement of 2nd rotary axis started 1x = 1st measurement of 2nd rotary axis is OK 2x = 2nd measurement of 2nd rotary axis is OK 3x = 3rd measurement of 2nd rotary axis is OK 33 = Both rotary axes measured	-
_OVR[41,42,43] ²⁾	1. Measurement of 1st rotary axis	mm
_OVR[44,45,46] ²⁾	2. Measurement of 1st rotary axis	mm
_OVR[47,48,49] ²⁾	3. Measurement of 1st rotary axis	mm
_OVR[51,52,53] ²⁾	1. Measurement of 2nd rotary axis	mm
_OVR[54,55,56] ²⁾	2. Measurement of 2nd rotary axis	mm
_OVR[57,58,59] ²⁾	3. Measurement of 2nd rotary axis	mm
_OVR[60,61,62]	Measuring positions, rotary axis 1 for 1st, 2nd, 3rd measurement	mm
_OVR[63,64,65]	Measuring positions, rotary axis 2 for 1st, 2nd, 3rd measurement	mm
_OVR[66,67,68]	Active rotation of the WO for 1st measurement of rotary axis 1 in XYZ	mm
_OVR[69,70]	Reserved	-
_OVR[71]	Actual calibration ball diameter from the 1st measurement of rotary axis 1	mm

- 1) The linear vectors are assigned to the specific vectors of the kinematics (I1, I2, etc.) in accordance with the normalizing process.
- 2) At the start of the 1st measurement, the intermediate results (sphere center points) of the rotary axis are deleted.
 At 1st measurement of 1st rotary axis → deletion of _OVR[41] ... _OVR[49]
 At 1st measurement of 2nd rotary axis → deletion of _OVR[51] ... _OVR[59]

Programming example

```
;* _OVR[60,61,62] -> measuring positions, rotary axis 1
;* _OVR[63,64,65] -> measuring positions, rotary axis 2
;* _OVR[66,67,68] -> active frame for 1st measurement, rotary axis 1
;* _OVR[69] free
;* _OVR[70] free
;* _OVR[71] -> actual calibration ball diameter from 1st measurement, rotary axis 1

;Measure kinematics
;Mixed kinematics with a B axis around Y and C axis around Z (MIXED_BC).
;Calibration ball at 2*45 degrees, directly mounted on a table.
;WO in G56. Only the position of the calibration ball
;has to be specified in the initial state of the kinematics (B=0 C=0).
;Determine G56 with measuring spigot in the JOG mode and approach in XY,
;then set ball north pole Z=0.
;Swivel data must be entered according to the machine drawing dimensions -> _SDA _SDE.
;Intermediate positions are approached with active TRAORI.
;To do this, using the online tool offset TOFFL, the TCP
;is shifted to the center of the measuring ball.

;Measuring positions for MIXED_BC
;P1 .. P3 rotary axis 1
;P4 .. P6 rotary axis 2

DEF REAL _P1[2]=SET(0,0) ;Measuring point P1 rotary axis 1(B), rotary axis 2(C)
DEF REAL _P2[2]=SET(45,0)
DEF REAL _P3[2]=SET(-45,0)
DEF REAL _P4[2]=SET(0,0)
DEF REAL _P5[2]=SET(0,90)
DEF REAL _P6[2]=SET(0,180)

DEF REAL _BALL=25 ;Calibration ball diameter
DEF REAL _SAVB=1 ;Safety clearance above the calibration ball

;Globally pre-assign measuring parameters
_FA=_SAVB*3
_TSA=_SAVB*4

REPEAT _SDA _SDE ;Read-in swivel data set

MSG(" load transformation data. OK ?? ")
M0
STOPRE
MSG()
;GOTOF _MCA ;Only calculate kinematics _OVR[40] to _OVR[71] OK
```

2.3 Measure workpiece (milling)

```
G17
CYCLE800()
ORIAxes ORIMKS
TRAORI
G56
T="3D-TASTER" D1
M6

IF (NOT $P_SEARCH) AND (NOT $P_ISTEST) AND (NOT $P_SIM)
    _OVR[40]=0 ;Zero the measuring counter
ENDIF

; ----- 1. Measurement, rotary axis 1
N99 G1 G710 G90 Z30 FFWON F2000
TOFFL=_BALL/2+_SAVB
D1 B=_P1[0] C=_P1[1] ;Kinematics initial state
TOFFL=0 ;Online correction of the tool length
X0 Y0 Z=_SAVB

;Circle around the ball
CYCLE996(10101,1,1,_BALL,0,0,0,0,0,0,0,0,_FA,_TSA,1,,1,)
M1
STOPRE

TOROT
M1
Z=IC(-_FA+_SAVB)
TOROTOF
M1

; ----- 2. Measurement, rotary axis 1
G1 F2000
TOFFL=_BALL/2+_SAVB ;When repositioning, correct the tool online
B=_P2[0] C=_P2[1]
TOFFL=0 ;Disable online correction again
;Circle around the ball, starting angle 45 degrees
CYCLE996(10102,1,1,_BALL,45,0,0,0,0,0,0,0,_FA,_TSA,1,,1,)

TOROT
Z=IC(-_FA+_SAVB) ;Approach starting position
TOROTOF
```

```

;----- 3. Measurement, rotary axis 1
G1 F2000
TOFFL=_BALL/2+_SAVB
D1 B=_P3[0] C=_P3[1]
TOFFL=0
CYCLE996(10103,1,1,_BALL,210,0,0,0,0,0,0,0,0,_FA,_TSA,1,,1,)
TOROT
Z=IC(-_FA+_SAVB)
TOROTOF

;----- 1. Measurement, rotary axis 2
;Initial state, 1st measurement, rotary axis 1 = 1st measurement, rotary axis 2
_OVR[51]=_OVR[41] _OVR[52]=_OVR[42] _OVR[53]=_OVR[43]
IF (NOT $P_SEARCH) AND (NOT $P_ISTEST) AND (NOT $P_SIM)
    _OVR[40]=_OVR[40]+10
ENDIF

;----- 2. Measurement, rotary axis 2
G1 F2000
TOFFL=_BALL/2+_SAVB
D1 B=_P5[0] C=_P5[1]
TOFFL=0
M1
CYCLE996(20102,1,1,_BALL,0,0,0,0,0,0,0,0,0,_FA,_TSA,1,,1,)
TOROT
Z=IC(-_FA+_SAVB)
TOROTOF

;----- 3rd measurement, rotary axis 2
TOFFL=_BALL/2+_SAVB
G1 D1 C=_P6[1] F2000
TOFFL=0
CYCLE996(20103,1,1,_BALL,_STA1,0,0,0,0,0,0,0,0,0,_FA,_TSA,1,,1,)
TOROT
Z=IC(-_FA+_SAVB)
TOROTOF
ENDIF
GO Z30
B0 C0

;----- Calculate kinematics
_MCA:
;Display data set. Save data set as protocol file
;Normalizing rotary axis 2(C) on Z=0 -> table upper edge
CYCLE996(13001000,1,1,_BALL,_STA1,0,0,0,0,0.02,0.001,22,_FA,_TSA,1,,1,101)

```

2.3 Measure workpiece (milling)

```

MSG("Kinematics measurement OK")
M1
M30 ;end of program

;-----
_SDA:                                ;Swivel data set according to machine drawing
TCARR=0
TRAFOOF
TCARR=0
$TC_CARR1[1]=-25 $TC_CARR2[1]=0 $TC_CARR3[1]=-121                ;I1xyz
$TC_CARR4[1]=25 $TC_CARR5[1]=0 $TC_CARR6[1]=121                ;I2xyz
$TC_CARR7[1]=0 $TC_CARR8[1]=1 $TC_CARR9[1]=0                    ;V1 axis B around Y
$TC_CARR10[1]=0 $TC_CARR11[1]=0 $TC_CARR12[1]=-1                ;V2 axis C around Z
$TC_CARR13[1]=0 $TC_CARR14[1]=0
$TC_CARR15[1]=0 $TC_CARR16[1]=0 $TC_CARR17[1]=0                ;I3xyz
$TC_CARR18[1]=0 $TC_CARR19[1]=0 $TC_CARR20[1]=0                ;I4xyz
$TC_CARR23[1]="M"
$TC_CARR24[1]=0 $TC_CARR25[1]=0
$TC_CARR26[1]=0 $TC_CARR27[1]=0
$TC_CARR28[1]=0 $TC_CARR29[1]=0
$TC_CARR30[1]=-92 $TC_CARR31[1]=0
$TC_CARR32[1]=92 $TC_CARR33[1]=360
$TC_CARR34[1]="MIXED_BC"
$TC_CARR35[1]="B" $TC_CARR36[1]="C"
$TC_CARR37[1]=415003003

;Trafo-MDs
N21102 $MC_ORI_DEF_WITH_G_CODE=0
N21104 $MC_ORI_IPO_WITH_G_CODE=1

N24100 $MC_TRAFO_TYPE_1=72
N24110 $MC_TRAFO_AXES_IN_1[3]=4                                    ;B
N24110 $MC_TRAFO_AXES_IN_1[4]=5                                    ;C
N24120 $MC_TRAFO_GEOAX_ASSIGN_TAB_1[0]=1
N24120 $MC_TRAFO_GEOAX_ASSIGN_TAB_1[1]=2
N24120 $MC_TRAFO_GEOAX_ASSIGN_TAB_1[2]=3
N24574 $MC_TRAFO5_BASE_ORIENT_1[2]=1
N24582 $MC_TRAFO5_TCARR_NO_1=1

N42940 $SC_TOOL_LENGTH_CONST=0
N42950 $SC_TOOL_LENGTH_TYPE=0

STOPRE
NEWCONF
_SDE:

```

2.4 Measure tool (turning)

2.4.1 General information

The measuring cycles below are intended for use on turning machines.

Note

Spindle

Spindle commands in the measuring cycles always refer to the active master spindle of the control.

When using the measuring cycles at machines with several spindles, then the spindle involved must be defined as master spindle before the cycle call.

References: /PG/ Programming Manual *SINUMERIK 840D sl / 828D Fundamentals*

Plane definition

The measuring cycles work internally with the 1st and 2nd axes of the actual plane G17 to G19.

The default setting for lathes is G18.

Note

The measuring cycle for tool measurement, turning (CYCLE982) does not position in the 3rd axis (Y for G18). The user must position in the 3rd axis.

Machine/workpiece-related measuring/calibrating

- Machine-related measuring/calibrating:

Measuring is performed in the basic coordinate system (machine coordinate system with kinematics transformation disabled).

The switching positions of the tool probe refer to the machine zero. Data from the following general setting data are used (PLUS and MINUS define the traversing direction of the tool):

- ① SD 54625 \$SNS_MEA_TP_TRIG_MINUS_DIR_AX1
- ② SD 54626 \$SNS_MEA_TP_TRIG_PLUS_DIR_AX1
- ③ SD 54627 \$SNS_MEA_TP_TRIG_MINUS_DIR_AX2
- ④ SD 54628 \$SNS_MEA_TP_TRIG_PLUS_DIR_AX2

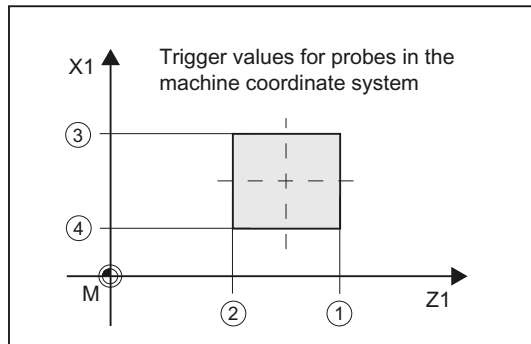

Figure 2-18 Tool probe, machine-related (G18)

- Workpiece-related measuring/calibrating:

The switching positions of the tool probe refer to the workpiece zero.

Data from the following general setting data are used (PLUS and MINUS define the traversing direction of the tool):

- ① SD 54640 \$SNS_MEA_TPW_TRIG_MINUS_DIR_AX1
- ② SD 54641 \$SNS_MEA_TPW_TRIG_PLUS_DIR_AX1
- ③ SD 54642 \$SNS_MEA_TPW_TRIG_MINUS_DIR_AX2
- ④ SD 54643 \$SNS_MEA_TPW_TRIG_PLUS_DIR_AX2

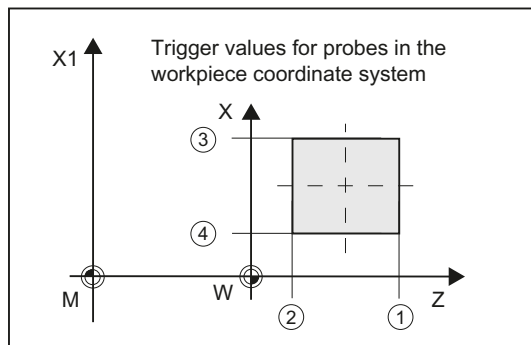

Figure 2-19 Tool probe, workpiece-related (G18)

Note

Workpiece-related or machine-related measurement requires an appropriately calibrated tool probe, see Chapter Calibrate probe (CYCLE982) (Page 184).

Compensation strategy

The tool measuring cycle is intended for various applications:

- First measurement of a tool (general setting data SD 54762 \$SNS_MEA_FUNCTION_MASK_TOOL Bit9):

The tool offset values in geometry and wear are replaced.

The offset is applied in the geometry component of the particular length.

The wear component is deleted.

- Post measurement of a tool (general setting data SD 54762 \$SNS_MEA_FUNCTION_MASK_TOOL Bit9):

The resulting difference is calculated into the wear component (length) of the tool.

Empirical values may optionally be included. A mean value is not calculated.

See also

Changes from cycle version SW4.4 and higher (Page 267)

2.4.2 Calibrate probe (CYCLE982)

Function

This measuring version can be used to calibrate a tool probe. Using the calibration tool, the actual distances between machine or workpiece zero and the probe trigger points are determined.

Values are corrected without empirical and mean values.

Note

If a special calibration tool is not available, a turning tool can be used instead with cutting edge positions 1 to 4 for the calibration of two sides of the probe.

Measuring principle

Calibration with calibration tool

The calibration tool is shaped (angled) in such a way that the probe can be calibrated on all four sides with it.

Calibration with turning tool

When a turning tool is used for calibration, the probe can only be calibrated on two sides.

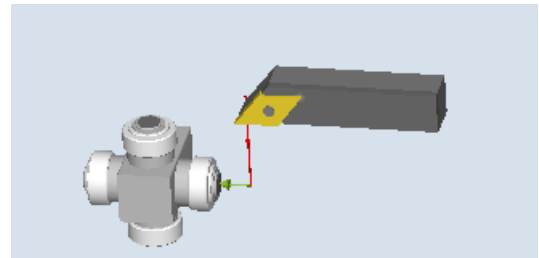
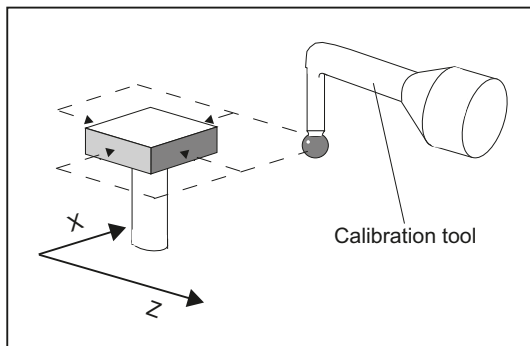

Calibrating the tool probe with a calibration tool Calibrating a tool probe with a turning tool

The cycle positions the calibration or turning tool to the probe. With a cycle call, the switching position in the specified measuring axis and measuring direction is calibrated.

Requirements

- Lengths 1 and 2 and the radius of the calibration or turning tool must be known exactly and stored in a tool offset data record.
This tool offset must be active when the measuring cycle is called.
- A 3D probe, turning (tool type 580) must be specified as tool type.
- Calibration with a calibration or turning tool with cutting edge positions 1 to 4 is possible.
- The lateral surfaces of the probe cube must be aligned parallel to the machine axes Z1, X1 (axes of the plane).
- The approximate positions of the switching surface of the probe regarding the machine or workpiece zero must be entered before calibration starts in the general setting data (see Commissioning Manual *SINUMERIK Operate (IM9) / SINUMERIK 840D sl*, Chapter "Tool measurement in turning").

These values are used for automatic approach to the probe with the calibration tool and their absolute value must not deviate from the actual value by more than the value in parameter TSA.

The probe must be reached within the total path $2 \cdot \text{DFA}$.

Starting position before the measurement

Calibrating the tool probe with a calibration tool Calibrating a tool probe with a turning tool

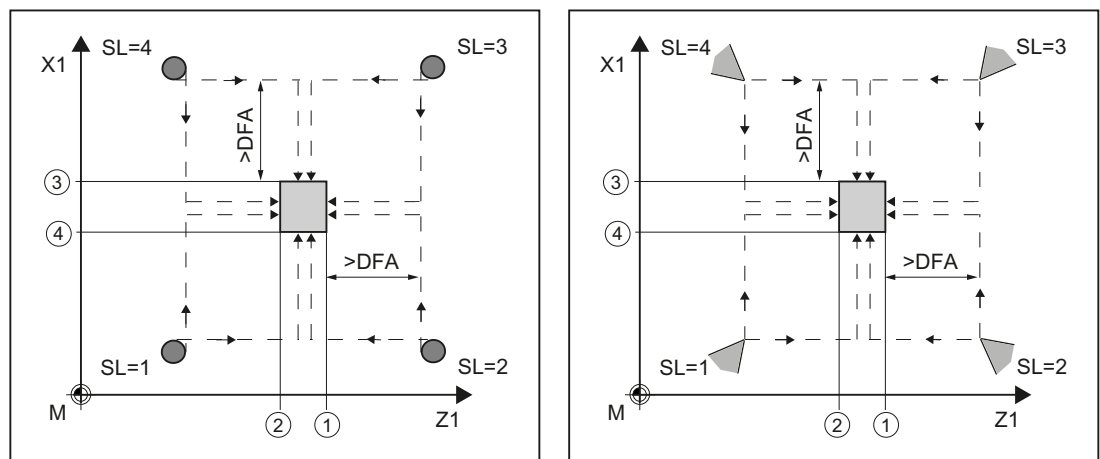

Cutting edge positions 1 to 4 and suitable approach positions for both axes (machine-related)

- ① trigger point of the 1st measuring axis in the negative direction (general SD 54625)
- ② trigger point of the 1st measuring axis in the positive direction (general SD 54626)
- ③ trigger point of the 2nd measuring axis in the negative direction (general SD 54627)
- ④ trigger point of the 2nd measuring axis in the positive direction (general SD 54628)

The cycle handles the approach to the probe.

Position after the end of the measuring cycle

The calibration or turning tool is located by the measurement path away from the measuring surface.

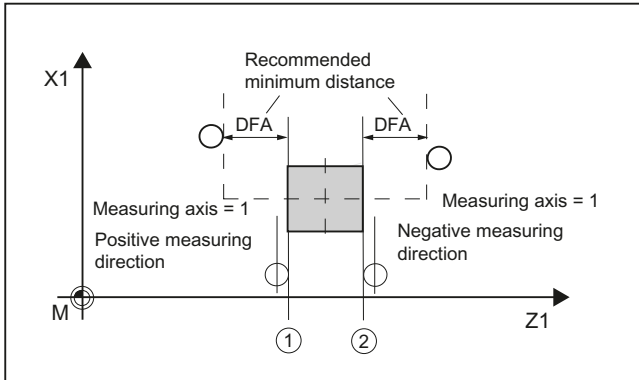

- ① Trigger point of the 1st measuring axis in the positive direction (general SD 54626)
- ② Trigger point of the 1st measuring axis in the negative direction (general SD 54625)

Figure 2-20 Position after the end of the measuring cycle, example, 1st axis of the plane (for G18: Z)

Procedure

The part program or ShopTurn program to be processed has been created and you are in the editor.



1. Press the "Meas. tool" softkey.



2. Press the "Calibrate probe" softkey.

The input window "Calibrate: probe" is opened.

Parameters

G code program			ShopTurn program		
Parameters	Description	Unit	Parameters	Description	Unit
	Calibration data set (1 - 6)	-	T	Name of the calibration tool	-
F	Calibration and measuring feedrate	Distance/min	D	Cutting edge number (1 - 9)	-
				Calibration data set (1 - 6)	-
			F	Calibration and measuring feedrate	mm/min
			β	Tool alignment with swivel axis <ul style="list-style-type: none"> • ← (0 degrees) • ↓ (90 degrees) • Value entry 	Degrees
			V	Tool orientation with a tool spindle	Degrees
			Z	Start point Z of the measurement	mm
			X	Start point X of the measurement	mm
			Y	Start point Y of the measurement	mm

Parameters	Description	Unit
Measuring axis 	Measuring axis (for measuring plane G18) <ul style="list-style-type: none"> • X • Z 	-
DFA	Measurement path	mm
TSA	Safe area for the measurement result	mm

List of the result parameters

The measuring variant "Calibrate probe" provides the following result parameters:

Table 2- 34 "Calibrate probe" result parameters

Parameters	Description	Unit
_OVR[8]	Trigger point in minus direction, actual value of 1st axis of the plane	mm
_OVR[10]	Trigger point in plus direction, actual value of 1st axis of the plane	mm
_OVR[12]	Trigger point in minus direction, actual value of 2nd axis of the plane	mm
_OVR[14]	Trigger point in plus direction, actual value of 2nd axis of the plane	mm
_OVR[9]	Trigger point in minus direction, difference of 1st axis of the plane	mm
_OVR[11]	Trigger point in plus direction, difference of 1st axis of the plane	mm
_OVR[13]	Trigger point in minus direction, difference of 2nd axis of the plane	mm
_OVR[15]	Trigger point in plus direction, difference of 2nd axis of the plane	mm
_OVR[27]	Zero offset area	mm
_OVR[28]	Safe area	mm
_OVI[2]	Measuring cycle number	-
_OVI[3]	Measuring variant	-
_OVI[5]	Probe number	-
_OVI[9]	Alarm number	-

2.4.3 Turning tool (CYCLE982)

Function

With this measuring version, the tool length (L1 and/or L2) of a turning tool with cutting edge positions 1 to 8 can be determined. The measuring version checks whether the difference to be corrected with respect to the old tool length lies within a defined tolerance range:

- Upper limits: Safe area TSA and dimensional difference control DIF
- Lower limit: Zero offset range TZL

If this range is not violated, the new tool length is accepted in the tool offset, otherwise an alarm is output. Violation of the lower limit is not corrected.

Measuring principle

For "complete" measuring, all lengths of a turning tool are measured:

- Turning tool with cutting edge positions 1 to 4: L1 and L2
- Turning tool with cutting edge position 5 or 7: L2
- Turning tool with cutting edge position 6 or 8: L1

If the turning tool has a cutting edge position 1 to 4, contact is made with the probe in both axes of the plane (for G18 Z and X), whereby the measurement starts with the 1st axis of the plane (for G18 Z). For cutting edge positions 5 to 8, a measurement is only performed in one axis:

- Cutting edge position 5 or 7: 1st measuring axis for G18 Z
- Cutting edge position 6 or 8: 2nd measuring axis for G18 X.

When measuring "axis by axis", the length of the turning tool in the parameterized measuring axis is measured.

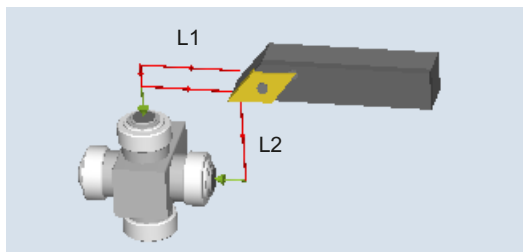

Figure 2-21 Measure: Turning tool (CYCLE982), example: Complete measuring

Requirements

The tool probe must be calibrated, see Calibrate probe (CYCLE982) (Page 184).

The approximate tool dimensions must be entered in the tool offset data:

- Tool type 5xx
- Cutting edge position, cutting edge radius
- Length 1, length 2

The tool to be measured must be active with its tool offset values when the cycle is called.

Starting position before the measurement

Before the cycle is called, the tool must be moved to the tool tip starting position, as shown in the following diagram.

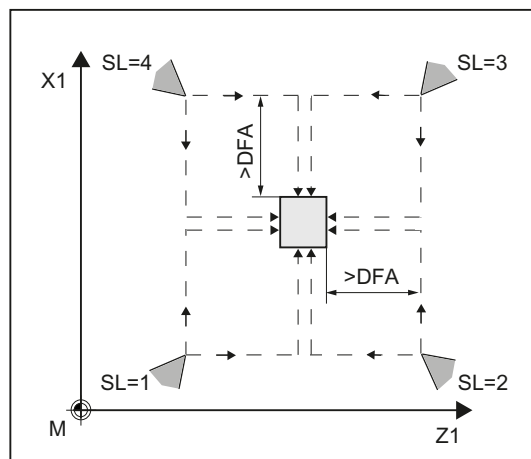

Figure 2-22 Cutting edge positions 1 to 4 and suitable starting positions for both axes

The center of the tool probe and the approach distance are calculated automatically and the required traversing blocks generated. The center of the cutting edge radius is positioned at the center of the probe.

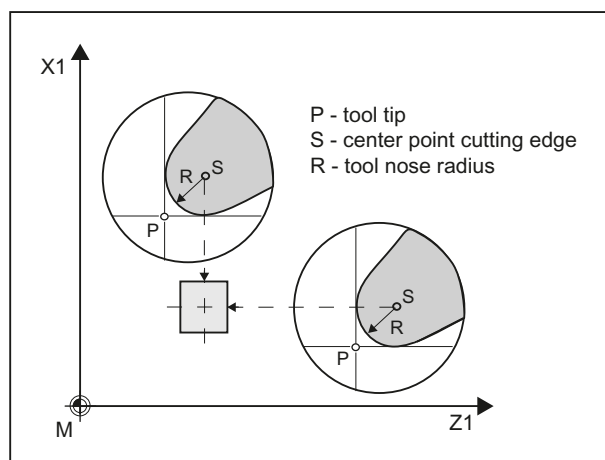

Figure 2-23 Measuring the length of a turning tool: Offset by the cutting edge radius, example SL=3

Position after the end of the measuring cycle

For an "axis by axis" measurement, the tool tip is the measurement path distance away from the probed measuring surface of the probe.

For a "complete" measurement, after the measurement, the tool is positioned at the starting point before the cycle was called.

Procedure

The part program or ShopTurn program to be processed has been created and you are in the editor.



1. Press the "Meas. tool" softkey.



2. Press the "Turning tool" softkey.

The input window "Measure: turning tool" is opened.

Parameters

G code program			ShopTurn program		
Parameters	Description	Unit	Parameters	Description	Unit
PL	Measuring plane (G17 - G19)	-	T	Name of the tool to be measured	-
	Calibration data set (1 - 6)	-	D	Cutting edge number (1 - 9)	-
				Calibration data set (1 - 6)	-
			β	Tool alignment with swivel axis: <ul style="list-style-type: none"> • (0 degrees) • (90 degrees) • Value entry 	Degrees
			V	Tool orientation with a tool spindle	Degrees
			Z	Start point Z of the measurement	mm
			X	Start point X of the measurement	mm
			Y	Start point Y of the measurement	mm

Parameters	Description	Unit
Measure	Measure tool lengths (for measuring plane G18) <ul style="list-style-type: none"> • Complete (measure length Z and length X) • Only measure tool length Z • Only measure tool length X 	-
DFA	Measurement path	mm

Parameters	Description	Unit
TSA	Safe area for the measurement result	mm
TZL	Tolerance range for work offset	mm
TDIF	Tolerance range for dimensional difference monitoring	mm

List of the result parameters

The measuring variant "Turning tool" provides the following result parameters:

Table 2- 35 "Turning tool" result parameters

Parameters	Description	Unit
_OVR[8]	Length actual value L1	mm
_OVR[9]	Length difference L1	mm
_OVR[10]	Length actual value L2	mm
_OVR[11]	Length difference L2	mm
_OVR[27]	Work offset range	mm
_OVR[28]	Safe area	mm
_OVR[29]	Permissible dimensional difference	mm
_OVR[30]	Empirical value	mm
_OVI[0]	D number	-
_OVI[2]	Measuring cycle number	-
_OVI[3]	Measuring version	-
_OVI[5]	Probe number	-
_OVI[7]	Empirical value memory number	-
_OVI[8]	Tool number	-
_OVI[9]	Alarm number	-

2.4.4 Milling tool (CYCLE982)

Function

This measuring version can be used to measure a milling tool on a turning machine (lathe).

The following measurements can be performed:

- Length
- Radius
- Length and radius

The measuring cycle checks whether the difference to be corrected with respect to the old tool length or to the old tool radius lies within a defined tolerance range:

- Upper limits: Safe area TSA and dimensional difference control DIF,
- Lower limit: Zero offset range TZL.

If this range is not violated, the new tool length is accepted in the tool offset, otherwise an alarm is output. Violation of the lower limit is not corrected.

The tool length correction is realized depending on the particular turning machine (lathe). The length assignment (L1 in X, L2 in Y) to the geometry axes is realized just the same as for a turning tool.

Measuring principle

For a "complete" measurement, all measured variables that can be determined (lengths L1 and L2 and radius) are determined. Contact is made with the probe in both axes of the plane (for G18 Z and X), whereby the measurement starts with the 1st axis of the plane (for G18: Z).

For an "axis by axis" measurement, the measured variables are measured corresponding to the selection "only length (L1 or L2)", "only radius" or "length (L1 or L2) and radius" only in the parameterized measuring axis of the active plane.

Measuring "axis by axis" - only length (L1 or L2)

Length L1 or L2 is measured in the parameterized measuring axis.

Table 2- 36 Measuring "axis by axis" - only length (L1 or L2)

Without milling tool reversal		With milling tool reversal
<p>Measuring length L2</p>	<p>Measuring length L1</p>	<p>Measuring length L1 Requirement: Radius R must be known.</p>

Measuring "axis by axis" - only radius

The radius in the parameterized measuring axis is measured by probing twice at the probe.

Table 2- 37 Measuring "axis by axis" - only radius

Without milling tool reversal	With milling tool reversal
<p>Starting position of the tool at the beginning of the cycle</p>	<p>Starting position of the tool at the beginning of the cycle</p>

Measuring "axis by axis" - only length (L1 or L2) and radius

Length L1 or L2 and radius are measured in the parameterized measuring axis by probing twice to two different sides of the measuring probe.

Table 2- 38 Measuring "axis by axis" - only length (L1 or L2) and radius

Length L1 and radius measurement without milling tool reversal	Length L2 and radius measurement with milling tool reversal

Measuring "complete" - lengths (L1 and L2) and radius

For complete measurements, all offsets are determined:

- Both lengths and radius (four measurements),
- If the radius is specified to be 0, then only both lengths are determined (two measurements).

The measuring cycle generates the approach blocks to the probe and the transverse motions to measure length 1, length 2 and the radius. A correctly selected start position is needed.

Milling tool reversal

When measuring with reversal, to start, the measuring point in the selected axis and a milling spindle position according to starting angle SPOS is measured. Then the tool (spindle) is turned through 180 degrees and measured again.

The average value is the measured value. Measurement with reversal results in a second measurement at each measuring point with a spindle rotation through 180 degrees with respect to the starting angle. The offset angle entered in SCOR is summed to these 180 degrees. This enables selection of a specific 2nd milling cutting edge that is offset from the 1st cutting edge by precisely 180 degrees. Measurement with reversal permits measurement of two cutting edges of one tool. The mean value is the offset value.

Tool position

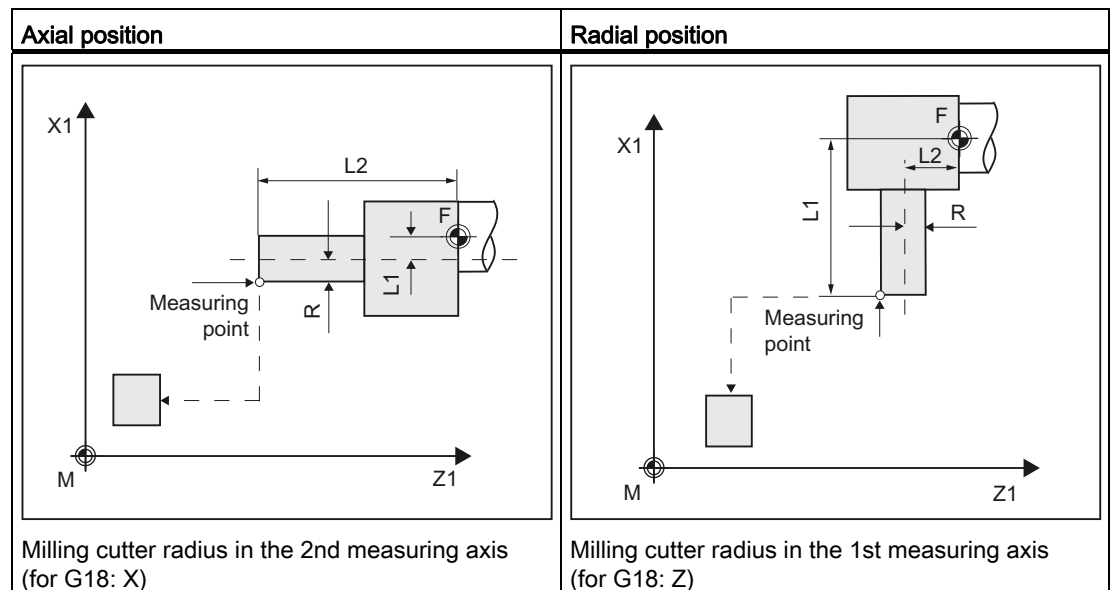

Measurement with rotating / stationary spindle

Measurement is possible with a rotating (M3, M4) or with a stationary milling spindle (M5).

If the milling spindle is stationary, at the beginning it is positioned at the specified starting angle SPOS.

Note

Measurement with rotating spindle

If selection of a specific milling tool cutting edge is not possible, it is possible to measure with a rotating spindle. The user must then program the direction of rotation, speed, and feedrate very carefully before calling up CYCLE982 to prevent damage to the probe. A low speed and feedrate must be selected.

Empirical values may optionally be included. A mean value is not calculated.

Requirements

- The tool probe must be calibrated, see Calibrate probe (CYCLE982) (Page 184).
- The approximate tool dimensions must be entered in the tool offset data:
 - Tool type: 1xy (milling tool)
 - Radius, length 1, length 2.
- The tool to be measured must be active with its tool offset values when the cycle is called.
- For a milling cutter, the channel-specific SD 42950: \$SC_TOOL_LENGTH_TYPE = 2 must be set (length is taken into account just the same as for a turning tool).
- The tool spindle must be declared as the master spindle.

Starting position before the measurement

From the starting position, collision-free approach to the probe must be possible.

The initial positions are located outside the unauthorized area (see the diagram below).

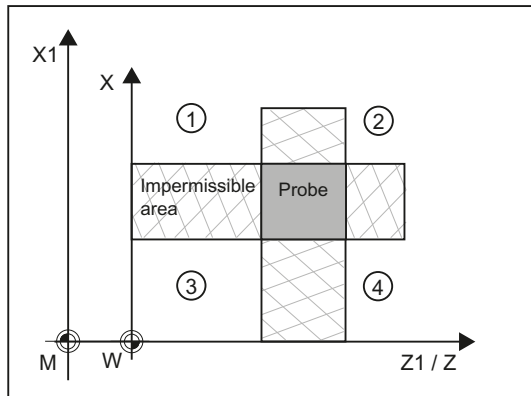

① to ④ permissible area

Figure 2-24 Measure milling cutter: Possible starting positions in the 2nd axis of the plane (for G18: X)

Position after the end of the measuring cycle

For an "axis by axis" measurement, the tool tip is positioned at the measurement path distance away from the last probed measuring surface of the probe.

For a "complete" measurement, after the measurement, the tool is positioned at the starting point before the cycle was called.

Procedure

The part program or ShopTurn program to be processed has been created and you are in the editor.



1. Press the "Meas. tool" softkey.



2. Press the "Milling tool" softkey.
The input window "Measure: Milling tool" is opened.

Parameters

G code program			ShopTurn program		
Parameters	Description	Unit	Parameters	Description	Unit
PL	Measuring plane (G17 - G19)	-	T	Name of the tool to be measured	-
	Calibration data set (1 - 6)	-	D	Cutting edge number (1 - 9)	-
				Calibration data set (1 - 6)	-
			β	Tool alignment with swivel axis <ul style="list-style-type: none"> (0 degrees) (90 degrees) Value entry 	Degrees
			Z	Start point Z of the measurement	mm
			X	Start point X of the measurement	mm
			Y	Start point Y of the measurement	mm

Parameters	Description	Unit
Measurement type	<ul style="list-style-type: none"> Axis-by-axis Complete (measure length and radius) 	-
Tool position	<ul style="list-style-type: none"> Axial (\leftarrow) Radial (\downarrow) 	-
For measurement type "Complete":		
Measure	Lengths X, Z and radius (in accordance with the tool position)	-
Cutting edge	<ul style="list-style-type: none"> End face Rear face 	-
Approach	Approach probe from the following direction (for measuring plane G18): <ul style="list-style-type: none"> In the case of tool position "axial": +/- X In the case of tool position "radial": +/- Z 	-
For measurement type "Axis-by-axis":		
Measure	For measuring plane G18: <ul style="list-style-type: none"> Length X/Z and radius (in accordance with the tool position) Only length Z Only length X Only radius 	-
Milling tool reversal	<ul style="list-style-type: none"> Yes (measurement with reversal of the milling tool (180°)) No (measurement without reversal) 	-
Position spindle	Set position of the tool spindle (only for milling tool reversal "No") <ul style="list-style-type: none"> No (any tool spindle position) Yes (position tool spindle at starting angle) 	-

2.4 Measure tool (turning)

Parameters	Description	Unit
SPOS	Angle for positioning on a tool tip (only for milling cutter reversal "Yes" or position spindle "Yes" or for "complete" measurement type)	Degrees
SCOR	Offset angle for reversal (only for milling tool reversal "Yes")	Degrees
DFA	Measurement path	mm
TSA	Safe area for the measurement result	mm
TZL	Tolerance range for work offset	mm
TDIF	Tolerance range for dimensional difference monitoring	mm

List of the result parameters

The measuring variant "Milling tool" provides the following result parameters:

Table 2- 39 "Milling tool" result parameters

Parameters	Description	Unit
_OVR[8]	Length actual value L1	mm
_OVR[9]	Length difference L1	mm
_OVR[10]	Length actual value L2	mm
_OVR[11]	Length difference L2	mm
_OVR[12]	Radius actual value	mm
_OVR[13]	Radius difference	mm
_OVR[27]	Work offset range	mm
_OVR[28]	Safe area	mm
_OVR[29]	Permissible dimensional difference	mm
_OVR[30]	Empirical value	mm
_OVI[0]	D number	-
_OVI[2]	Measuring cycle number	-
_OVI[5]	Probe number	-
_OVI[7]	Empirical value memory	-
_OVI[8]	Tool number	-
_OVI[9]	Alarm number	-

2.4.5 Drill (CYCLE982)

Function

With this measuring version, the tool length (L1 or L2) of a drill can be measured. The measuring version checks whether the difference to be corrected with respect to the old tool length lies within a defined tolerance range:

- Upper limits: Safe area TSA and dimensional difference control DIF
- Lower limit: Zero offset range TZL

If this range is not violated, the new tool length is accepted in the tool offset, otherwise an alarm is output. Violation of the lower limit is not corrected.

Measuring principle

The length (L1 or L2) of the drill is measured in the parameterized measuring axis.

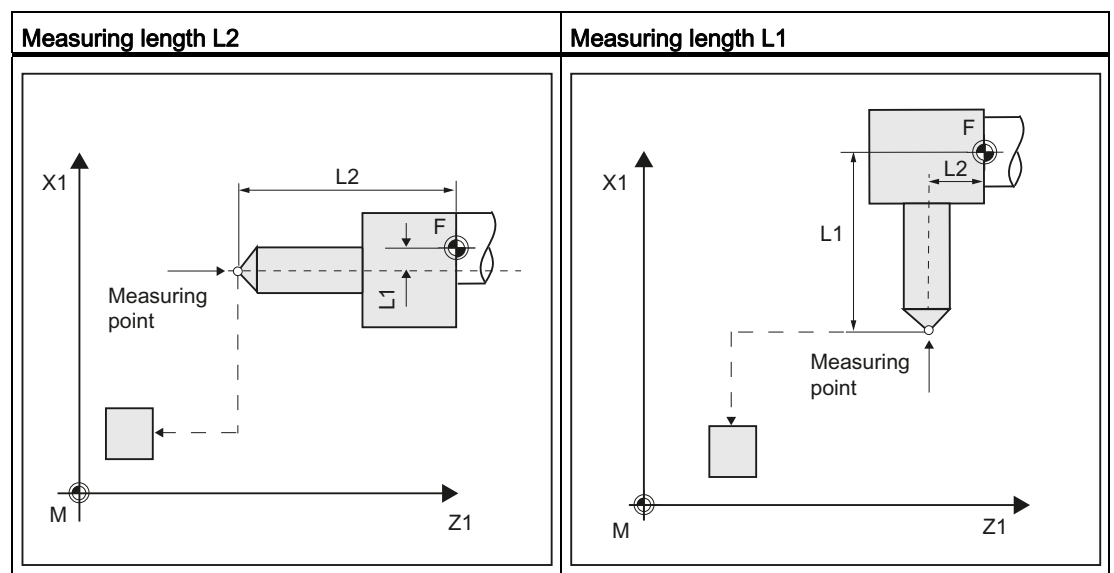

Tool position:

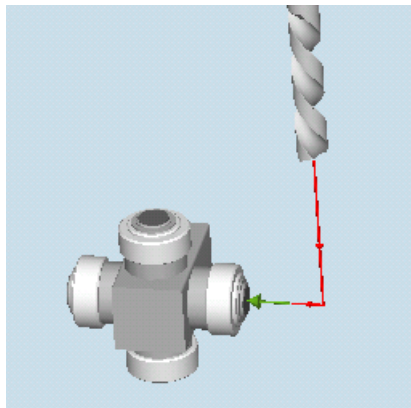
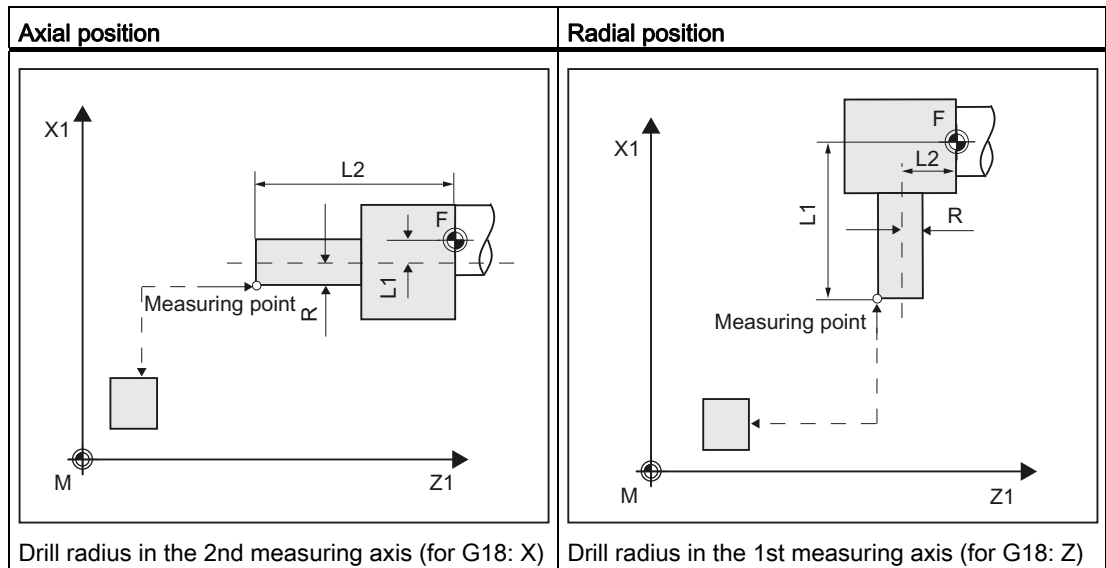

Figure 2-25 Measure: drill (CYCLE982), example , tool position: ↓ radial position

Note

If the length of the drill is measured by approaching the probe from the side, then it must be ensured that the drill to be measured does not deflect the probe in the area of the twist groove or in the area of its drill tip.

The requirement is that the drill radius was entered in the tool offset, otherwise, an alarm will be output.

Requirements

- The tool probe must be calibrated.
- The approximate tool dimensions must be entered in the tool offset data:
 - Tool type: 2xy (drill)
 - Length 1, length 2
- The tool to be measured must be active with its tool offset values when the cycle is called.
- The channel-specific SD 42950: \$SC_TOOL_LENGTH_TYPE should be assigned 2 as standard (length assignment the same as for turning tools). For special applications, a value 0 can be used, see Measure drills - special applications (Page 199).

Starting position before the measurement

From the starting position, collision-free approach to the probe must be possible.

The initial positions are located outside the unauthorized area (see the diagram below).

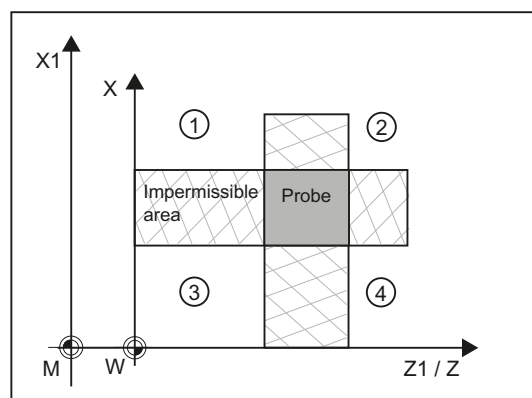

① to ④ permissible area

Figure 2-26 Measure drill: Possible starting positions in the 2nd axis of the plane (for G18: X)

Position after the end of the measuring cycle

The tool tip is positioned at the measurement path from the measuring surface.

Measure drill - special applications

The tool probe has been calibrated with **G18** active as is usual for turning tools.

Function

If **drills** are used on lathes with a length compensation as for milling machines (SD 42950: \$SC_TOOL_LENGTH_TYPE=0), then a drill can also be measured (gauged) in this application.

Length L1 is always calculated in the 3rd axis (tool offset axis) of the actual plane G17 to G19. This also characterizes the position of the tool.

G17: L1 in Z axis (corresponds to axial position)

G18: L1 in Y axis (no turning machine application)

G19: L1 in X axis (corresponds to radial position)

Conditions

Length L1 is determined if the following conditions are satisfied:

- the active tool is of type 2xy (drill)
- Channel-specific SD 42950: \$SC_TOOL_LENGTH_TYPE=0
- G17 or G19 are active and

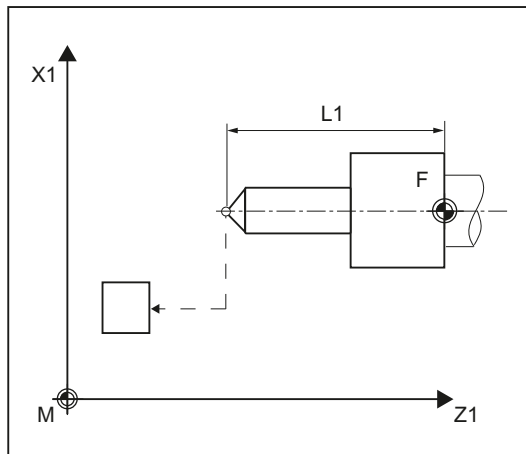

Measure drill length L1 for G17

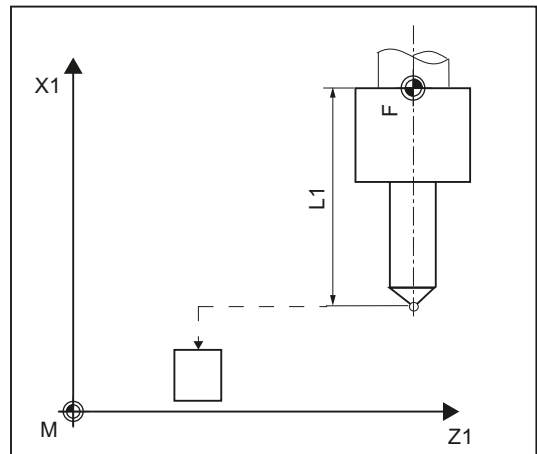

Measure drill length L1 for G19

Procedure

The part program or ShopTurn program to be processed has been created and you are in the editor.











1. Press the "Meas. tool" softkey.



2. Press the "Drill" softkey.

The input window "Measure: drill" is opened.

Parameters

G code program			ShopTurn program		
Parameters	Description	Unit	Parameters	Description	Unit
PL 	Measuring plane (G17 - G19)	-	T	Name of the tool to be measured	-
 	Calibration data set (1 - 6)	-	D 	Cutting edge number (1 - 9)	-
Tool position 	<ul style="list-style-type: none"> • Axial (←) • Radial (↓) 	-	 	Calibration data set (1 - 6)	-
			β 	Tool alignment with swivel axis <ul style="list-style-type: none"> • ← (0 degrees) • ↓ (90 degrees) • Value entry 	Degrees
			Z	Start point Z of the measurement	mm
			X	Start point X of the measurement	mm
			Y	Start point Y of the measurement	mm

Parameters	Description	Unit
DFA	Measurement path	mm
TSA	Safe area for the measurement result	mm
TZL	Tolerance range for work offset	mm
TDIF	Tolerance range for dimensional difference monitoring	mm

List of the result parameters

The measuring variant "Drill" provides the following result parameters:

Table 2- 40 "Drill" result parameters

Parameters	Description	Unit
_OVR[8]	Length actual value L1	mm
_OVR[9]	Length difference L1	mm
_OVR[10]	Length actual value L2	mm
_OVR[11]	Length difference L2	mm
_OVR[27]	Work offset range	mm
_OVR[28]	Safe area	mm
_OVR[29]	Permissible dimensional difference	mm
_OVR[30]	Empirical value	mm
_OVI[0]	D number	-
_OVI[2]	Measuring cycle number	-
_OVI[3]	Measuring version	-
_OVI[5]	Probe number	-
_OVI[7]	Empirical value memory	-
_OVI[8]	Tool number	-
_OVI[9]	Alarm number	-

2.4.6 Measure tool with toolholder that can be orientated

Overview

The functionality is designed for a specific configuration on turning machines (turning/milling machines). As well as the linear axes (Z and X) and main spindle, the turning machines must have swivel axis about Y with accompanying tool spindle. The swivel axis can be used to align the tool on the X/Z level.

Preconditions

- The lateral surfaces of the tool probe should be aligned parallel to the relevant axes (machine or workpiece coordinate system in the 1st and 2nd axis of the plane). The tool probe must be calibrated in the measuring axis and direction in which measuring will be performed.
- The tool to be measured must be active with its tool offset values when the cycle is called.
- When measuring turning tools, the cutting edge position of the tool must be entered in the tool offset in accordance with the **basic position of the tool carrier**.
- When measuring drilling and milling tools, the setting data must be
SD 42950: TOOL_LENGTH_TYPE = 2
i.e., lengths are assigned to the axes in the same way as for turning tools.
- The active level must be G18.

Function

To take into account the tool carrier that can be orientated in measuring cycle CYCLE982, MD 51740 \$MNS_MEA_FUNCTION_MASK bit16 must be set.

Table 2- 41 MD 51740 \$MNS_MEA_FUNCTION_MASK:

Bit16 = 1 Support using a tool carrier that can be orientated, positioned probes/tools

When measuring turning tools, especially roughers, finishers and mushroom-shaped tools, the swivel axis can assume any position around Y. Multiples of 90° are permitted for milling and drilling tools. Multiples of 180° are possible when positioning the tool spindle.

This is monitored within the cycle.

If turning tools are measured around Y using any positions (not multiples of 90°) of the swivel axis, then it should be taken into consideration that the turning tool is measured with the same tool position in both axes X/Z, assuming that this is possible.

Sequence

Before CYCLE 982 is called, the tool must be aligned in the same way as it will eventually be measured.

The tool should be preferably aligned with CYCLE800, refer to the Operating Manual *Turning*, Chapter "Swivel plane/align tool (CYCLE800)".

Please note that the measuring cycle assumes that the tool has been aligned in advance.

From the position adopted by the tool, it must be possible to approach the probe in X, Z via the measuring cycle.

The measuring procedure that follows is the same as for the measuring variants when the tool carrier is in its basic position.

Note

Measuring milling tools

The following measuring version is not supported when using a tool carrier that can be orientated:

Measuring type: "complete" and cutting edge: measure "rear side".

When this measuring version is used, alarm 61037: "Incorrect measuring version" is output.

2.5 Measure tool (milling)

2.5.1 General information

The measuring cycles described in this chapter are intended for use on milling machines and machining centers.

Note

Spindle

Spindle commands in the measuring cycles always refer to the active master spindle of the control.

When using the measuring cycles at machines with several spindles, then the spindle involved must be defined as master spindle before the cycle call.

References: /PG/ "Programming Guide: Fundamentals"

Plane definition

For milling machines and machining centers, the default setting is the actual machining plane G17.

Machine/workpiece-related measuring/calibrating

- Machine-related measuring/calibrating:

Measuring is performed in the basic coordinate system (machine coordinate system with kinematics transformation disabled).

The switching positions of the tool probe refer to the machine zero. Data from the following general setting data are used:

- ① SD 54625 \$SNS_MEA_TP_TRIG_MINUS_DIR_AX1
- ② SD 54626 \$SNS_MEA_TP_TRIG_PLUS_DIR_AX1
- ③ SD 54627 \$SNS_MEA_TP_TRIG_MINUS_DIR_AX2
- ④ SD 54628 \$SNS_MEA_TP_TRIG_PLUS_DIR_AX2

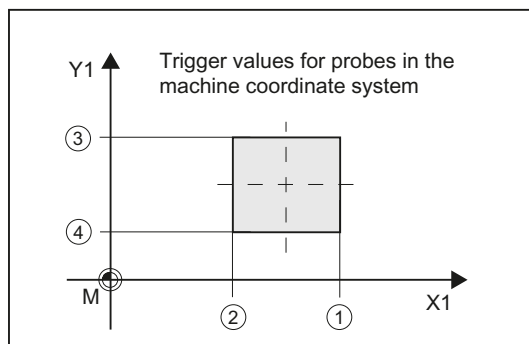

Figure 2-27 Tool probe, machine-related (G17)

- Workpiece-related measuring/calibrating:
The switching positions of the tool probe refer to the workpiece zero.
Data from the following general setting data are used:
 - ① SD 54640 \$SNS_MEA_TPW_TRIG_MINUS_DIR_AX1
 - ② SD 54641 \$SNS_MEA_TPW_TRIG_PLUS_DIR_AX1
 - ③ SD 54642 \$SNS_MEA_TPW_TRIG_MINUS_DIR_AX2
 - ④ SD 54643 \$SNS_MEA_TPW_TRIG_PLUS_DIR_AX2

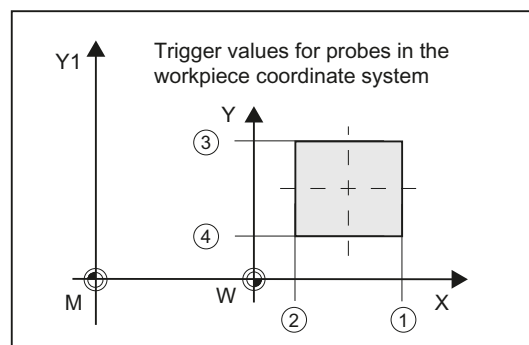

Figure 2-28 Tool probe, workpiece-related (G17)

Note

Workpiece-related or machine-related measurement requires an appropriately calibrated tool probe, see Chapter Calibrate probe (CYCLE971) (Page 208).

Compensation strategy

The tool measuring cycle is intended for various applications:

- Initial measurement of a tool (general setting data SD 54762 \$SNS_MEA_FUNCTION_MASK_TOOL[Bit 9]):
The tool offset values in geometry and wear are replaced.
The offset is applied in the geometry component of the length or the radius.
The wear component is deleted.
- Post measuring a tool (general setting data SD 54762 \$SNS_MEA_FUNCTION_MASK_TOOL[Bit 9]):
The resulting difference is calculated into the wear component (links or radius) of the tool.
Empirical values may optionally be included. A mean value is not calculated.

2.5.2 Calibrate probe (CYCLE971)

Function

This measuring version can be used to calibrate a tool probe machine-related or workpiece-related.

Values are corrected without empirical and mean values.

Measuring principle

The current clearances between machine zero (machine-related calibration) or workpiece zero (workpiece-related calibration) and the probe trigger point are determined with the aid of the calibration tool. The cycle positions the calibration tool to the probe.

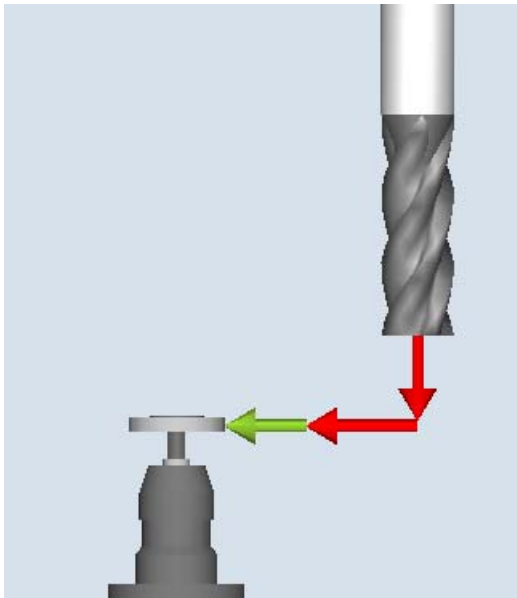

Calibrate: Probe (CYCLE971), axis-by-axis

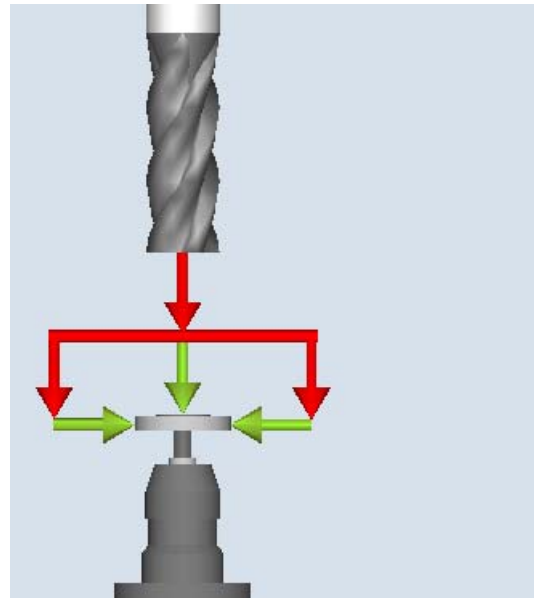

Calibrate: Probe (CYCLE971), complete

Axis-by-axis calibration

For "axis by axis" calibration, the probe is calibrated in the parameterized measuring axis and measuring direction. The probing point can be centered in the offset axis. The actual center of the tool probe is determined first in the offset axis before the calibration is performed in the measuring axis.

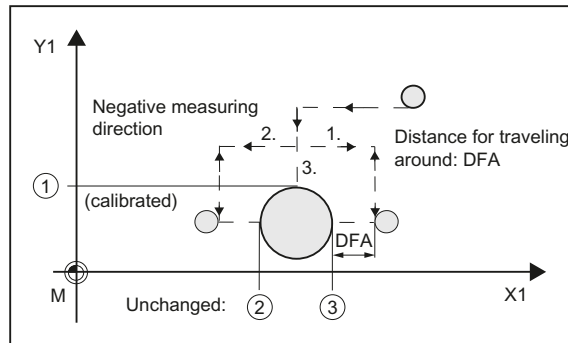

- ① General SD 54627 \$SNS_MEA_TP_TRIG_MINUS_DIR_AX2
- ② General SD 54626 \$SNS_MEA_TP_TRIG_PLUS_DIR_AX1
- ③ General SD 54625 \$SNS_MEA_TP_TRIG_MINUS_DIR_AX1

Figure 2-29 Calibrate probe (CYCLE971) with offset axis, example G17: Determine center in X, calibrate in Y

Complete calibration

The tool probes are automatically calibrated for the "complete" calibration. Using the calibration tool, the measuring cycle determines the tool probe trigger points in all axes or axis directions in which the probe can be approached.

See, Commissioning Manual *SINUMERIK Operate (IM9) / SINUMERIK 840D sl*, Chapter "Tool measurement in milling": General setting data SD 54632 \$SNS_MEA_TP_AX_DIR_AUTO_CAL or SD 54647 \$SNS_MEA_TPW_AX_DIR_AUTO_CAL.

The tool axis (for G17: Z) must always be able to be approached in the minus direction. Otherwise no "complete" calibration is possible. Calibration is started in the 3rd axis, followed by the axes of the plane. "Complete" calibration is shown in the following screens (example: G17).

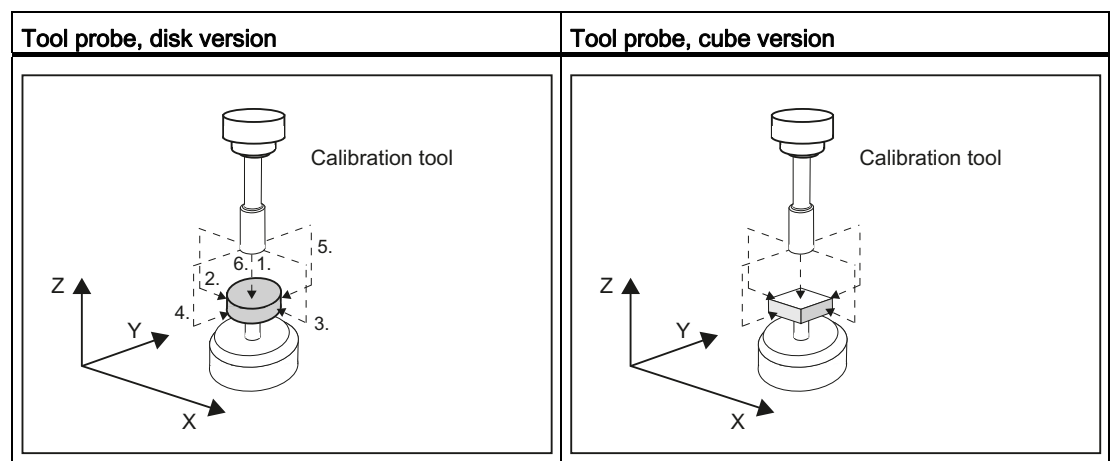

2.5 Measure tool (milling)

Before the first calibration operation in the plane, e.g. plus direction of the 1st axis, the precise center of the probe is determined in the other axis (2nd axis), as long as the probe can be approached in this axis. Additional movements are performed in the plane for this purpose.

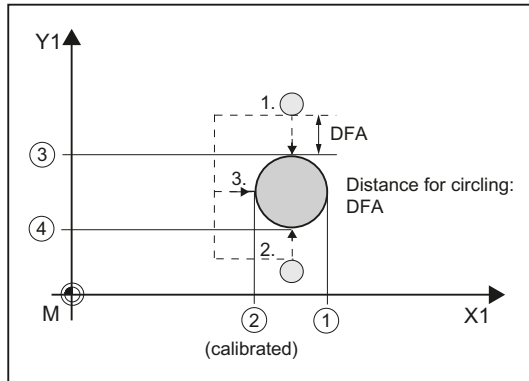

- ① General SD 54625 \$SNS_MEA_TP_TRIG_MINUS_DIR_AX1
- ② General SD 54626 \$SNS_MEA_TP_TRIG_PLUS_DIR_AX1
- ③ General SD 54627 \$SNS_MEA_TP_TRIG_MINUS_DIR_AX2
- ④ General SD 54628 \$SNS_MEA_TP_TRIG_PLUS_DIR_AX2

Figure 2-30 Determining the probe center in the 2nd axis of the plane, calibration +X

Requirements

- The exact length and radius of the calibration tool must be stored in a tool offset data record. This tool offset must be active when the measuring cycle is called.
- Tool type:
 - Calibration tool (type 725)
 - Milling tool (type 120)
- The machining plane G17 or G18 or G19 must be defined prior to the cycle call.
- The approximate coordinates of the tool probe must be entered in the general setting data before calibration starts (see Commissioning Manual *SINUMERIK Operate (IM9) / SINUMERIK 840D sl*, Chapter "Tool measurement in milling").

These values are used for automatic approach to the probe with the calibration tool and their absolute value must not deviate from the actual value by more than the value in parameter TSA.

- The probe must be reached within the total path $2 \cdot DFA$.

Starting position before the measurement

For **"axis by axis"** calibration, from the starting position, the cycle calculates the approach distance to the probe and generates the appropriate traversing blocks. It must be ensured that a collision-free approach is possible.

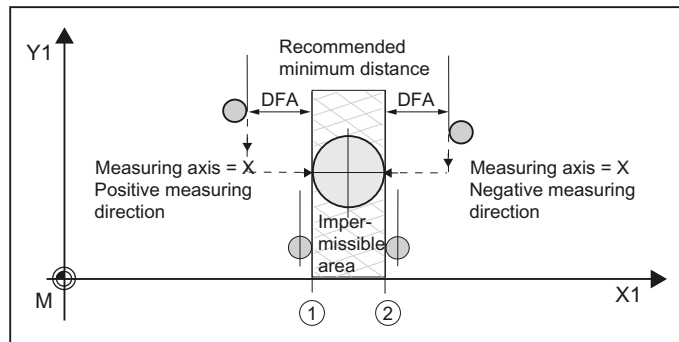

- ① General SD 54626 $\$SNS_MEA_TP_TRIG_PLUS_DIR_AX1$
- ② General SD 54625 $\$SNS_MEA_TP_TRIG_MINUS_DIR_AX1$

Figure 2-31 Starting positions for calibration in the plane, example: G17

Note

Calibrating in the 3rd axis of the measuring plane

If the tool diameter is smaller than the upper diameter of the probe, then the calibration tool is always positioned at the center of the probe.

If the tool diameter is larger, the calibration tool is positioned, offset by the tool radius, to the center of the probe. The value of the offset is subtracted.

For **"complete"** calibration, the position before the cycle call should be selected so that a collision-free, centered approach is possible above the probe center by measuring path DFA. The axis sequence for the approach is first the tool axis (3rd axis) followed by the axes of the plane.

Position after the end of the measuring cycle

For **"axis by axis"** calibration, the calibration tool is positioned above the measuring surface by measuring path DFA.

For **"complete"** calibration, the calibration tool is positioned about the center of the probe by measuring path DFA.

Parameter	Description	Unit
Spindle reversal 	Compensation of eccentricity through spindle reversal ¹⁾ <ul style="list-style-type: none"> • Yes • No 	-
V	Lateral offset (only for measuring axis "Z", for G17) The offset is active when calibrating the 3rd measuring axis, if the calibration tool diameter is larger than the upper diameter of the probe. Here, the tool is offset from the center of the probe by the tool radius, minus the value of V. An offset axis must be specified.	mm
DFA	Measurement path	mm
TSA	Safe area for the measurement result	mm

¹⁾ The "Spindle reversal" function is shown if bit 11 is set in the general SD 54782
\$SNS_MEA_FUNCTIONS_MASK_TOOL.

List of the result parameters

The measuring variant "Calibrate probe" provides the following result parameters:

Table 2- 42 "Calibrate probe" result parameters

Parameters	Description	Unit
_OVR [8]	Trigger point in minus direction, actual value of 1st geometry axis	mm
_OVR [10]	Trigger point in plus direction, actual value of 1st geometry axis	mm
_OVR [12]	Trigger point in minus direction, actual value of 2nd geometry axis	mm
_OVR [14]	Trigger point in plus direction, actual value of 2nd geometry axis	mm
_OVR [16]	Trigger point in minus direction, actual value of 3rd geometry axis	mm
_OVR [18]	Trigger point in plus direction, actual value of 3rd geometry axis	mm
_OVR [9]	Trigger point in minus direction, difference of 1st geometry axis	mm
_OVR [11]	Trigger point in plus direction, difference of 1st geometry axis	mm
_OVR [13]	Trigger point in minus direction, difference of 2nd geometry axis	mm
_OVR [15]	Trigger point in plus direction, difference of 2nd geometry axis	mm
_OVR [17]	Trigger point in minus direction, difference of 3rd geometry axis	mm
_OVR [19]	Trigger point in plus direction, difference of 3rd geometry axis	mm
_OVR [27]	Work offset range	mm
_OVR [28]	Safe area	mm
_OVI [2]	Measuring cycle number	-
_OVI [3]	Measuring version	
_OVI [5]	Probe number	-
_OVI [9]	Alarm number	-

2.5.3 Measure tool (CYCLE971)

Function

With this measuring version, the tool length or the tool radius of milling and drilling tools can be measured. With milling tools, optionally the cutting edge length or the cutting edge radius can be measured (e.g. to check whether individual cutting edges of the milling tool have been broken out), see Section Single cutting edge measurement.

A check is made whether the difference to be corrected in the entered tool length or to the entered tool radius in the tool management lies within a defined tolerance range:

- Upper limit: Safe area TSA and dimensional difference control DIF
- Lower limit: Zero offset range TZL

When this area is maintained, the measured tool length or the tool radius is entered in the tool management, otherwise a message is output. Violation of the lower limit is not corrected.

Measuring is possible either with:

- Stationary spindle (see Section Tool measurement with stationary spindle)
- Rotating spindle (see Section Tool measurement with rotating spindle)

Note

The single cutting edge measurement is only possible in conjunction with the "Tool measurement with rotating spindle" function!

Measuring principle

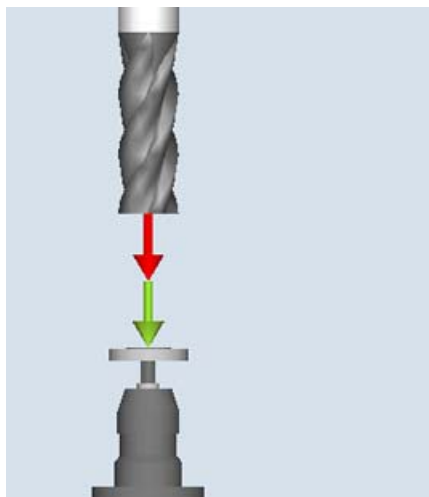

Measure: tool (CYCLE971),
example, length

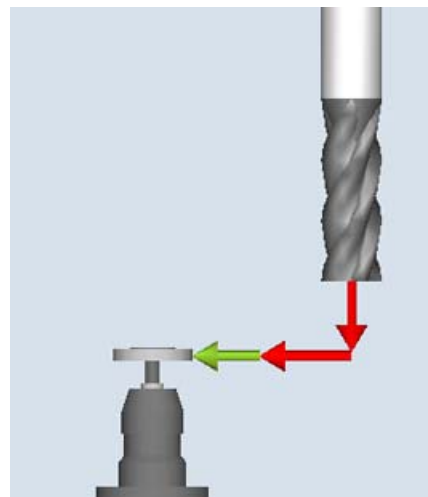

Measure: tool (CYCLE971),
example, radius

The tool must always be aligned perpendicular to the probe before the measuring cycle is called, i.e. the tool axis is parallel to the center line of the probe.

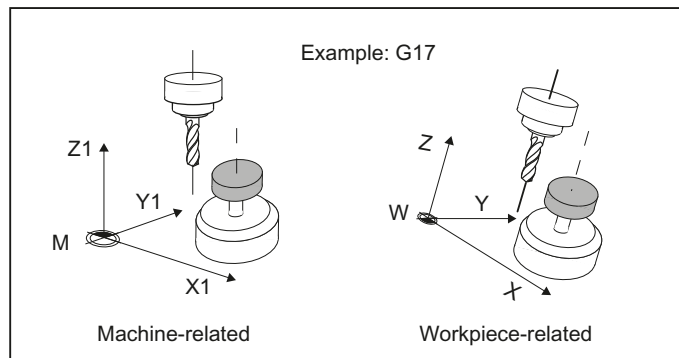

Figure 2-32 Parallel alignment of tool axis, probe axis and axis of the coordinate system

Length measurement

If the tool diameter is less than the upper diameter of the probe, then the tool is always positioned at the center of the probe.

if the tool diameter is larger, the tool is positioned offset by the tool radius toward the center onto the probe. The value of the offset is subtracted.

If no offset axis is specified, if necessary an offset is realized in the 1st axis of the plane (with G17: X axis).

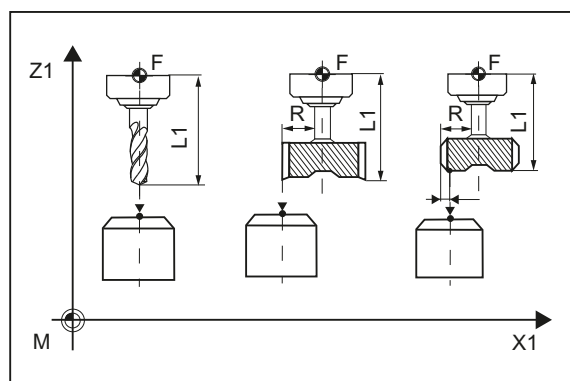

Figure 2-33 Length measurement with and without offset

Radius measurement

The tool radius is measured using lateral probing at the probe in the parameterized measuring axis and measuring direction (see the following diagram).

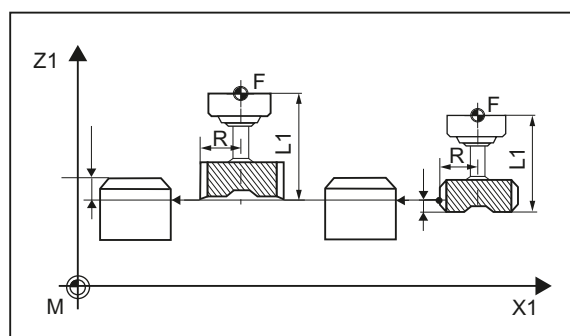

Figure 2-34 Radius measurement with and without offset

Requirements

Note

The tool probe must be calibrated before the tool measurement (see Calibrate probe (CYCLE971) (Page 208)).

- The tool geometry data (approximate values) must be entered in a tool offset data record.
- The tool must be active.
- The machining plane must be programmed in which the probe was calibrated.
- The tool must be prepositioned in such a way that collision-free approach with the probe is possible in the measuring cycle.

Starting position before the measurement

Before the cycle call, a starting position must be assumed from which the probe can be approached collision-free. The measuring cycle calculates the direction of approach and generates the appropriate traversing blocks.

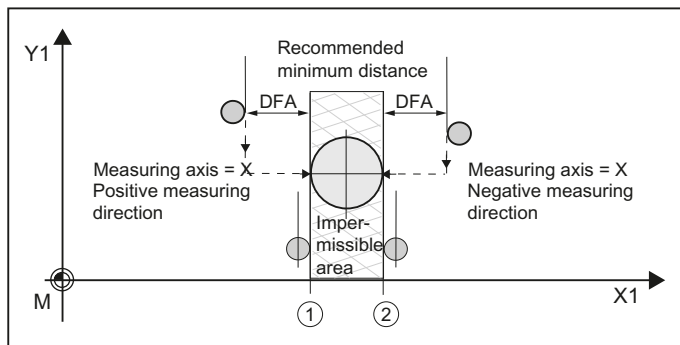

- ① General SD 54626 \$SNS_MEA_TP_TRIG_PLUS_DIR_AX1
- ② General SD 54625 \$SNS_MEA_TP_TRIG_MINUS_DIR_AX1

Figure 2-35 Calibrate probe (CYCLE971), starting positions for calibration in the plane

Position after the end of the measuring cycle

The tool is positioned at the measurement path distance away from the measuring surface.

Tool measurement with stationary spindle

When measuring milling tools, before the measuring cycle is called, the tool with the spindle must be rotated so that the selected cutting edge can be measured (length or radius).

Tool measurement with rotating spindle

Typically, measurements of the radius of milling tools are executed with rotating spindle, which means that the largest cutting edge determines the measuring result.

Likewise, it can make sense to measure the length of milling tools with the spindle rotating.

The following must be taken into account:

- Is it permissible to use the tool probe to perform measurements with rotating spindle with length and/or radius calculation? (manufacturer data)
- Permissible peripheral (circumferential) speed for the tool to be measured
- Maximum permissible speed
- Maximum permissible feedrate when probing
- Minimum feedrate when probing
- Selecting the direction of rotation depending on the cutting edge geometry to avoid a hard impact when probing at the probe
- Specified measuring accuracy

When performing a measurement with rotating tool, the ratio between the measuring feedrate and speed must be taken into account. In this case, a cutting edge is considered. For multiple cutting edges, the longest cutting edge is responsible for the measuring result.

The following interrelationships have to be taken into account:

$$n = S / (2\pi \cdot r \cdot 0.001)$$

$$F = n \cdot \Delta$$

Where:

		Basic system	
		<i>Metric</i>	<i>Inch</i>
n	Speed	rev/min	rev/min
S	Max. permissible peripheral speed	m/min	Feet/min
r	Tool radius	mm	Inch
F	Measuring feedrate	mm/min	inch/min
Δ	Measuring accuracy	mm	Inch

Special issues when performing measurements with rotating spindle

- As standard, the feedrate and speed with the limit values defined in the general setting data SD 54670 - SD 54677 for peripheral speed, speed, minimum feedrate maximum feedrate and measuring accuracy, as well as the intended direction of spindle rotation for measurement are calculated in a cycle (see Commissioning Manual *SINUMERIK Operate (IM9) / SINUMERIK 840D sl*, Chapter "Tool measurement in milling - monitoring for measuring with rotating spindle")

Measuring is conducted by probing twice; the 1st probing action causes a higher feedrate. A maximum of three probing operations are possible for measuring. If probing is performed several times the speed is additionally reduced on the last probing operation.

By setting the general SD 54740 \$SNS_MEA_FUNCTION_MASK[Bit19], this speed reduction can be suppressed.

2.5 Measure tool (milling)

- Using the general SD 54762 \$SNS_MEA_FUNCTION_MASK_TOOL[Bit5], the user can hide the cycle-internal calculation and enter the values for feedrate and speed via the input screen form of the cycle.

To specify the values with bit 5 set in the general SD 54762

\$SNS_MEA_FUNCTION_MASK_TOOL, the input fields in the screen form F1 (feedrate 1) and S1 (speed 1), F2 (feedrate 2) and S2 (speed 2) or F3 (feed 3) and S3 (Speed 3) are used. For the first probing, the values of F1 and S1 are effective, and for the second probing the values F2 and S2. If S2=0, only one probing action is performed. If S3>0 and S2>0, triple probing is performed, whereby for the 3rd probing, the values from F3 and S3 are effective.

The monitoring functions for the general setting data SD 54670 - SD 54677 are not active!

- If, when calling the measuring cycle, the spindle is stationary, then the direction of rotation is determined from the general SD 54674 \$SNS_MEA_CM_SPIND_ROT_DIR.

NOTICE

If, when calling a measuring cycle, the spindle is already rotating, then this direction of rotation is kept independent of the general SD 54674 \$SNS_MEA_CM_SPIND_ROT_DIR!

Single cutting edge measurement

The single cutting edge measurement can be used for remeasuring (offset in the wear) and initial measuring (offset in the geometry). Milling tools with up to 100 cutting edges can be measured.

A check is made as to whether the measured values of all cutting edges are within a defined tolerance range:

- Upper limit: Safe area TSA and dimensional difference control DIF
- Lower limit: Zero offset range TZL

If the measured values are outside the tolerance range, an alarm is output.

If the measured value of the longest cutting edge is within the tolerance range, this is entered in the tool management. Violation of the lower limit is not corrected.

Note

The single cutting edge measurement is only possible in conjunction with the Tool measurement with rotating spindle (Page 214) function.

Length measurement

The tool is positioned to the side of the probe and below the upper edge of the probe in the offset axis. To determine the spindle position of a cutting edge, the probe makes contact twice with the rotating tool.

This is followed by the length measurement with stationary spindle. For this purpose, the tool is positioned above the probe and offset by the tool radius to the center of the probe.

First, the cutting edge whose spindle position has been determined through lateral contact is measured. The other cutting edges are measured through spindle orientation.

After the measurements, the measured value of the longest cutting edge is entered in the tool offset, when this is within the tolerance range.

Radius measurement

For radius measurement, the distance between the cutting edges must be identical (example: A tool with three cutting edges has a cutting edge every 120 degrees).

The tool is positioned to the side of the probe and below the upper edge of the probe in the offset axis. To determine the spindle position of the longest cutting edge, the probe makes contact twice with the rotating tool.

The exact spindle position and the cutting edge radius at the highest point of the cutting edge are then measured through multiple contacts when the spindle is stationary.

The other cutting edges are measured by changing the spindle orientation. The measured radius of the longest cutting edge is entered in the tool offset, when the value is within the tolerance range.

Special features for single cutting edge measurement

The following additional requirements apply:

- The number of cutting edges of the milling tool must be entered in the tool offset.
- Tool spindle with position measuring system.
- The tool probe must be calibrated, see Calibrate probe (CYCLE971) (Page 208)

Before the cycle call, the tool must be positioned next to the probe and above the probe edge.

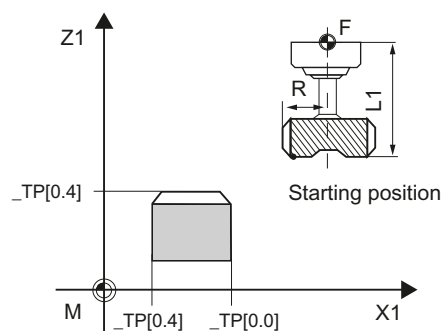

Figure 2-36 Single cutting edge measurement (CYCLE971), starting position before measuring cycle call

2.5 Measure tool (milling)

Procedure

The part program or ShopMill program to be processed has been created and you are in the editor.



1. Press the "Measure tool" softkey in the vertical softkey bar.



2. Press the "Measure tool" softkey in the horizontal softkey bar. The input window "Measure: tool" is opened.

Parameters

G code program			ShopMill program		
Parameter	Description	Unit	Parameter	Description	Unit
PL	Measuring plane (G17 - G19)	-	T	Name of the tool to be measured	-
	Calibration data record (1 - 6)	-	D	Cutting edge number (1 - 9)	-
				Calibration data record (1 - 6)	-

Parameter	Description	Unit
Measuring	<ul style="list-style-type: none"> Length (measure tool length) Radius (measure tool radius) 	-
Spindle	Behavior of spindle during measurement: <ul style="list-style-type: none"> Spindle stationary Spindle rotates 	-
Single cut. edge meas.	Single cutting edge measurement (only with "rotating spindle") ¹⁾ <ul style="list-style-type: none"> Yes No 	-
Only for measure "Radius":		-
Measuring axis	Corresponding to the set measuring plane: <ul style="list-style-type: none"> X (for G17) Y (for G17) 	-
DZ	Length offset (for G17)	mm
Only for measure "Length":		-
Tool offset	Offset axis <ul style="list-style-type: none"> No: The tool is measured, centered. In X In Y 	-
V	Lateral offset (only for tool offset in X / Y)	mm
DFA	Measurement path	mm
TSA	Safe area for the measurement result	mm

¹⁾ The "Single cutting edge measurement" function is shown if bit 10 is set in the general SD 54762 \$SNS_MEA_FUNCTIONS_MASK_TOOL .

List of the result parameters

The measuring variant "Measure tool" provides the following result parameters:

Table 2- 43 "Measure tool" result parameters

Parameter	Description	Unit
_OVR [8]	Actual value of length L1 ¹⁾ / length of the longest cutting edge ³⁾	mm
_OVR [9]	Difference of length L1 ¹⁾ / difference of length of the longest cutting edge ³⁾	mm
_OVR [10]	Actual value of radius R ²⁾ / actual value of radius of the longest cutting edge ⁴⁾	mm
_OVR [11]	Difference of radius R ²⁾ / difference of radius of the longest cutting edge ⁴⁾	mm
_OVR [12]	Actual value of length of the shortest cutting edge ³⁾	mm
_OVR [13]	Difference of length of the shortest cutting edge ³⁾	mm
_OVR [14]	Actual value of radius of the shortest cutting edge ⁴⁾	mm
_OVR [15]	Difference of radius of the shortest cutting edge ⁴⁾	mm
_OVR [27]	Zero offset range	mm
_OVR [28]	Safe area	mm
_OVR [29]	Permissible dimensional difference	mm
_OVR [30]	Empirical value	mm
_OVR [100] - _OVR [199]	Actual values of the individual radii ⁴⁾ .	mm
_OVR [200] - _OVR [299]	Difference of the individual radii ⁴⁾ .	mm
_OVR [300] - _OVR [399]	Actual value of the individual lengths ³⁾	mm
_OVR [400] - _OVR [499]	Difference of the individual lengths ³⁾	mm
_OVI [0]	D number	-
_OVI [2]	Measuring cycle number	-
_OVI [3]	Measuring version	-
_OVI [5]	Probe number	-
_OVI [7]	Number of the empirical value memory	-
_OVI [8]	T name	-
_OVI [9]	Alarm number	-

1) Only for measure "Length"

2) Only for measure "Radius"

3) Only for the "Single cutting edge measurement" function, measure cutting edge length

4) Only for the "Single cutting edge measurement" function, measure cutting edge radius

Parameter lists

3.1 Overview of measuring cycle parameters

3.1.1 CYCLE973 measuring cycle parameters

```
PROC CYCLE973 (INT S_MVAR, INT S_PRNUM, INT S_CALNUM, REAL S_SETV, INT S_MA, INT S_MD, REAL
S_FA, REAL S_TSA, REAL S_VMS, INT S_NMSP, INT S_MCBIT, INT _DMODE, INT _AMODE) SAVE ACTBLOCNO
DISPLOF
```

Table 3- 1 CYCLE973 call parameters ¹⁾

No.	Screen form parameters	Cycle parameters	Meaning
1		S_MVAR	<p>Measuring variant (default=0012103)</p> <p>Values:</p> <p>UNITS: Calibration on a surface, edge or in a groove 0 = Length on surface/edge (in the WCS) with known setpoint 1 = Radius on surface (in the WCS) with known setpoint 2 = Length in groove (in the WCS), see S_CALNUM 3 = Radius in groove (in the WCS), see S_CALNUM</p> <p>TENS: Reserved 0 = 0</p> <p>HUNDREDS: Reserved 1 = 1</p> <p>THOUSANDS: Selection of measuring axis and measuring direction for calibration ²⁾ 0 = No specification (for surface calibration on the groove bottom, no selection of the measuring axis and measuring direction) ⁴⁾ 1 = Specify selection of measuring axis and measuring direction, see S_MA, S_MD (one measuring direction in a measuring axis) 2 = Specify selection of measuring axis, see S_MA (two measuring directions in a measuring axis)</p> <p>TEN THOUSANDS: Determination of the positional deviation (probe skew) ^{2), 3)} 0 = Determine positional deviation 1 = Do not determine positional deviation</p> <p>HUNDRED THOUSANDS: Reserved 0 = 0</p> <p>MILLIONS: Determination of the tool length for calibration on a surface 0 = Do not determine tool length (only trigger points) 1 = Determine tool length</p>
2	Icon+ number	S_PRNUM	Number of the field of the probe parameters (not probe number) (default=1)
3		S_CALNUM	Number of the calibration groove for calibration on a groove (default=1) ⁵⁾

Parameter lists

3.1 Overview of measuring cycle parameters

No.	Screen form parameters	Cycle parameters	Meaning
4		S_SETV	Setpoint for calibration on a surface
5	X0	S_MA	Measuring axis (number of the axis) ⁶⁾ (default=1)
			Values: 1 = 1st axis of the plane (for G18 Z) 2 = 2nd axis of the plane (for G18 X) 3 = 3rd axis of the plane (for G18 Y)
6	+-	S_MD	Measuring direction (default=1)
			Values: 0 = Positive measuring direction 1 = Negative measuring direction
7	DFA	S_FA	Measurement path
8	TSA	S_TSA	Safe area
9	VMS	S_VMS	Variable measuring velocity for calibration ²⁾
10	Measurements	S_NMSP	Number of measurements at the same location ²⁾ (default=1)
11		S_MCBIT	Reserved
12		_DMODE	Display mode
			Values: UNITS: Machining plane G17/G18/G19 0 = compatibility, the plane active before the cycle call remains active 1 = G17 (only active in the cycle) 2 = G18 (only active in the cycle) 3 = G19 (only active in the cycle)

No.	Screen form parameters	Cycle parameters	Meaning
13		_AMODE	Alternative mode

- 1) All default values = 0 or marked as default=x
- 2) Display depends on the general SD 54760 \$SNS_MEA_FUNCTION_MASK_PIECE
- 3) Only relevant for calibration in two axis directions
- 4) Only measuring axis and measuring direction are determined automatically from the cutting edge position (SL) of the probe. SL=8 → -X , SL=7 → -Z
- 5) The number of the calibration groove (n) refers to the following general setting data (all positions in machine coordinate system):
For cutting edge SL=7:
SD54615 \$SNS_MEA_CAL_EDGE_BASE_AX1[n] Position of the base of the groove in the 1st axis of plane (for G18 Z)
SD54621 \$SNS_MEA_CAL_EDGE_PLUS_DIR_AX2[n] Position of the groove wall in the positive direction of the 2nd axis of the plane (for G18 X)
SD54622 \$SNS_MEA_CAL_EDGE_MINUS_DIR_AX2[n] Position of the groove wall in the negative direction of the 2nd axis of the plane
For cutting edge SL=8:
SD54619 \$SNS_MEA_CAL_EDGE_BASE_AX2[n] Position of the base of the groove in the 2nd axis of the plane
SD54620 \$SNS_MEA_CAL_EDGE_UPPER_AX2[n] Position of the upper edge of the groove in the 2nd axis of the plane, (only to pre-position the probe)
SD54617 \$SNS_MEA_CAL_EDGE_PLUS_DIR_AX1[n] Position of the groove wall in the positive direction of the 1st axis of the plane
SD54618 \$SNS_MEA_CAL_EDGE_MINUS_DIR_AX1[n] Position of the groove wall in the negative direction of the 1st axis of the plane
Note:
The position values for the groove wall +- can be roughly determined.
The slot width from the difference of the position values of the groove wall must be able to be precisely determined (precision dial gauge).
When calibrating in the groove, it is assumed that the tool length of the probe of the calibrated axis = 0.
The position values for the groove base must also be precisely determined at the machine (not a dimension drawing).
- 6) Measuring axis $S_{MA}=3$ for calibration on a surface and on a turning machine with real 3rd axis of the plane (for G18 Y).

3.1 Overview of measuring cycle parameters

3.1.2 CYCLE974 measuring cycle parameters

```
PROC CYCLE974 (INT S_MVAR, INT S_KNUM, INT S_KNUM1, INT S_PRNUM, REAL S_SETV, INT S_MA, REAL
S_FA, REAL S_TSA, REAL S_STA1, INT S_NMSP, STRING[32] S_TNAME, INT S_DLNUM, REAL S_TZL, REAL
S_TDIF, REAL S_TUL, REAL S_TLL, REAL S_TMV, INT S_K, INT S_EVNUM, INT S_MCBIT, INT _DMODE, INT
_AMODE) SAVE DISPLOF
```

Table 3-2 CYCLE974 call parameters ¹⁾

No.	Screen form parameters	Cycle parameters	Meaning
1		S_MVAR	Measuring version
			Values: UNITS: 0 = Measure front face 1 = Inside measurement 2 = Outside measurement
			TENS: Reserved
			HUNDREDS: Correction target 0 = Only measurement (no correction of the WO or no tool offset) 1 = Measurement, determination and correction of the WO (see S_KNUM) ³⁾ 2 = Measurement and tool offset (see S_KNUM1)
			THOUSANDS: Reserved
			TEN THOUSANDS: Measurement with or without reversal of the main spindle (workspindle) 0 = Measurement without reversal 1 = Measurement with reversal
2	Selection	S_KNUM	Correction in the work offset (WO) or basic WO or basic reference ²⁾
			Values: UNITS: TENS: 0 = No correction 1 to max. 99 numbers of the work offset or 1 to max. 16 numbers of the basic offset
			HUNDREDS: Reserved
			THOUSANDS: Correction in WO or basic WO or basic reference 0 = Correction of the adjustable WO 1 = Correction of the channel-specific basic WO 2 = Correction of the basic reference 3 = Correction of the global basic WO 9 = Correction of the active WO or for G500, last active channel-specific basic WO
			TEN THOUSANDS: Coarse or fine correction in the WO, basic WO or basic reference 0 = Fine correction ⁶⁾ 1 = Coarse correction
3	Selection	S_KNUM1	Correction in tool offset ^{2), 4)}
			Values: UNITS: TENS:

3.1 Overview of measuring cycle parameters

No.	Screen form parameters	Cycle parameters	Meaning
			<p>HUNDREDS: 0 = No correction 1 to max. 999 D numbers (cutting edge numbers) for tool offset; for additive and setup offset, see also S_DLNUM</p> <p>THOUSANDS: Reserved</p> <p>TEN THOUSANDS: Tool offset²⁾ 0 = No specification (offset in tool radius normal, not inverted) 1 = Offset inverted</p> <p>HUNDRED THOUSANDS: Tool offset²⁾ 0 = No specification (offset in tool radius) 1 = Offset of length L1 2 = Offset of length L2 3 = Offset of length L3</p> <p>MILLIONS: Tool offset²⁾ 0 = No specification (offset of the tool radius wear) 1 = Tool offset, additive offset (AO)⁵⁾ Tool offset value is added to the existing AO 2 = Tool offset, setup offset (SO)⁵⁾ SO (new) = SO (old) + AO (old) offset value, AO (new) = 0 3 = Tool offset, setup offset (SO)⁵⁾ Tool offset value is added to the existing SO 4 = Tool offset, geometry</p>
4	Icon+ number	S_PRNUM	Number of the field of the probe parameters (not probe number) (default=1)
5	X0	S_SETV	Setpoint
6	X	S_MA	Measuring axis (number of the axis) (default=1)
			Values: 1 = 1. axis of the plane (for G18 Z) 2 = 2nd axis of the plane (for G18 X) 3 = 3rd axis of the plane (for G18 Y) ⁵⁾
7	DFA	S_FA	Measurement path
8	TSA	S_TSA	Safe area
9	α	S_STAI	Starting angle for measurement with reversal
10	Measurements	S_NMSP	Number of measurements at the same location ²⁾ (default=1)
11	T	S_TNAME	Tool name ²⁾
12	DL	S_DLNUM	Setup additive offset DL number ⁵⁾
13	TZL	S_TZL	Work offset ^{2), 4)}
14	DIF	S_TDIF	Dimensional difference check ^{2), 4)}
15	TUL	S_TUL	Upper tolerance limit ⁴⁾
16	TLL	S_TLL	Lower tolerance limit ⁴⁾
17	TMV	S_TMV	Offset range for averaging ²⁾
18	FW	S_K	Weighting factor for averaging ²⁾
19	EVN	S_EVNUM	Number of the empirical mean value memory ^{2), 7)}
20		S_MCBIT	Reserved

Parameter lists

3.1 Overview of measuring cycle parameters

No.	Screen form parameters	Cycle parameters	Meaning
21		_DMODE	Display mode
			Values: UNITS: Machining plane G17/G18/G19 0 = compatibility, the plane active before the cycle call remains active 1 = G17 (only active in the cycle) 2 = G18 (only active in the cycle) 3 = G19 (only active in the cycle)
22		_AMODE	Alternative mode
			Values: UNITS: Dimensional tolerance yes/no 0 = No 1 = Yes

- 1) All default values = 0 or marked as default=x
- 2) Display depends on the general SD 54760 \$SNS_MEA_FUNCTION_MASK_PIECE
- 3) Correction in WO only possible for measurement without reversal
- 4) For tool offset in the channel-specific MD 20360 TOOL_PARAMETER_DEF_MASK , observe bit0 and bit1
- 5) Only if the "Setup additive offset" function has been set-up in the general MD 18108 \$MN_MM_NUM_SUMCORR. In addition, in the general MD 18080 \$MN_MM_TOOL_MANAGEMENT_MASK, bit8 must be set to 1.
- 6) If WO "fine" has not been set up in MDs, correction is according to WO "coarse"
- 7) Empirical averaging only possible for tool offset
Value range for empirical mean value memory:
1 to 20 numbers (n) of the empirical value memory, see channel-specific SD 55623 \$SCS_MEA_EMPIRIC_VALUE[n-1]
10000 to 200000 numbers (n) of the mean value memory, see channel-specific SD 55625 \$SCS_MEA_AVERAGE_VALUE[n-1]

3.1.3 CYCLE994 measuring cycle parameters

```
PROC CYCLE994 (INT S_MVAR, INT S_KNUM, INT S_KNUM1, INT S_PRNUM, REAL S_SETV, INT S_MA, REAL
S_SZA, REAL S_SZO, REAL S_FA, REAL S_TSA, INT S_NMSP, STRING [32] S_TNAME, INT S_DLNUM, REAL
S_TZL, REAL S_TDIF, REAL S_TUL, REAL S_TLL, REAL S_TMV, INT S_K, INT S_EVNUM, INT S_MCBIT, INT
_DMODE, INT _AMODE) SAVE DISPLOF
```

Table 3-3 CYCLE994 call parameters ¹⁾

No.	Screen form parameters	Cycle parameters	Meaning	
1		S_MVAR	Measuring version	
			Values:	UNITS: Inside or outside measurement (default = 1) 1 = Inside measurement 2 = Outside measurement
				TENS: Reserved
				HUNDREDS: Correction target 0 = Only measurement (no correction of the WO or no tool offset) 1 = Measurement and determination and correction of the WO (see S_KNUM) ³⁾ 2 = Measurement and tool offset (see S_KNUM1)
				THOUSANDS: Protection zone 0 = No consideration of a protection zone 1 = Consideration of a protection zone. Traverse axis, 1st axis of the plane (for G18 Z). Measuring axis, see S_MA. 2 = Consideration of a protection zone. Traverse axis, 2nd axis of the plane (for G18 X). Measuring axis, see S_MA. 3 = Consideration of a protection zone. Traverse axis, 3rd axis of the plane (for G18 Y). Measuring axis, see S_MA. ⁸⁾
2	Selection	S_KNUM	Correction of the work offset (WO) or basic WO or basic reference ²⁾	
			Values:	UNITS:
				TENS: 0 = No correction 1 to max. 99 numbers of the work offset or 1 to max. 16 numbers of the basic offset
				HUNDREDS: Reserved
				THOUSANDS: Correction of WO or basic or basic reference 0 = Correction of the adjustable WO 1 = Correction of the channel-specific basic WO 2 = Correction of the basic reference 3 = Correction of the global basic WO 9 = Correction of the active WO or for G500 in last active channel-specific basic WO
		TEN THOUSANDS: Coarse or fine correction in the WO, basic WO or basic reference 0 = Fine correction ⁶⁾ 1 = Coarse correction		
3	Selection	S_KNUM1	Correction in tool offset ^{2), 4)}	
			Values:	UNITS:
				TENS:

Parameter lists

3.1 Overview of measuring cycle parameters

No.	Screen form parameters	Cycle parameters	Meaning
			<p>HUNDREDS: 0 = No correction 1 to max. 999 D numbers (cutting edge numbers) for tool offset; for additive and setup offset, see also S_DLNUM</p> <p>THOUSANDS: Reserved</p> <p>TEN THOUSANDS: Tool offset²⁾ 0 = No specification (offset of tool radius normal, not inverted) 1 = Offset inverted</p> <p>HUNDRED THOUSANDS: Tool offset²⁾ 0 = No specification (offset of tool radius) 1 = Offset of length L1 2 = Offset of length L2 3 = Offset of length L3</p> <p>MILLIONS: Tool offset²⁾ 0 = No specification (offset of the tool radius wear) 1 = Tool offset, additive offset (AO) ⁵⁾ Tool offset value is added to the existing AO 2 = Tool offset, setup offset (SO) ⁵⁾ SO (new) = SO (old) + AO (old) offset value, AO (new) = 0 3 = Tool offset, setup offset (SO) ⁵⁾ Tool offset value is added to the existing SO 4 = Tool offset, geometry;</p>
4	Icon+ number	S_PRNUM	Number of the field of the probe parameters (not probe number) (default=1)
5	X0	S_SETV	Setpoint
6	X	S_MA	<p>Number of the measuring axis (default=1) ⁸⁾</p> <p>Values: 1 = 1st axis of the plane (for G18 Z) 2 = 2nd axis of the plane (for G18 X) 3 = 3rd axis of the plane (for G18 Y)</p>
7	X1	S_SZA	Length of the protection zone in the measuring axis
8	Y1	S_SZO	Length of the protection zone in the traverse axis
9	DFA	S_FA	Measurement path
10	TSA	S_TSA	Safe area
11	Measurements	S_NMSP	Number of measurements at the same location ²⁾ (default=1)
12	T	S_TNAME	Tool name ³⁾
13	DL	S_DLNUM	Setup additive offset DL number ⁵⁾
14	TZL	S_TZL	Work offset ^{2), 4)}
15	DIF	S_TDIF	Dimensional difference check ^{2), 4)}
16	TUL	S_TUL	Upper tolerance limit ⁴⁾
17	TLL	S_TLL	Lower tolerance limit ⁴⁾
18	TMV	S_TMV	Offset range for averaging ²⁾
19	FW	S_K	Weighting factor for averaging ²⁾
20	EVN	S_EVNUM	Number of the empirical value memory ^{2), 7)}
21		S_MCBIT	Reserved

No.	Screen form parameters	Cycle parameters	Meaning
22		_DMODE	Display mode
			Values: UNITS: Machining plane G17/G18/G19 0 = Compatibility, the plane active before the cycle call remains active 1 = G17 (only active in the cycle) 2 = G18 (only active in the cycle) 3 = G19 (only active in the cycle)
23		_AMODE	Alternative mode
			Values: UNITS: Dimensional tolerance yes/no 0 = No 1 = Yes

- 1) All default values = 0 or marked as default=x
- 2) Display depends on the general SD 54760 \$SNS_MEA_FUNCTION_MASK_PIECE
- 3) Correction in WO only possible for measurement without reversal
- 4) For tool offset, observe the channel MD 20360 TOOL_PARAMETER_DEF_MASK
- 5) Only if the "Setup additive offset" function has been set-up in the general MD 18108 \$MN_MM_NUM_SUMCORR. In addition, the general MD 18080 \$MN_MM_TOOL_MANAGEMENT_MASK, bit8 must be set to 1.
- 6) If WO "fine" has not been set up in MDs, correction is according to WO "coarse"
- 7) Empirical averaging only possible for tool offset
Value range for empirical mean value memory:
1 to 20 numbers (n) of the empirical value memory, see channel-specific SD 55623 \$SCS_MEA_EMPIRIC_VALUE[n-1]
10000 to 200000 numbers (n) of the mean value memory, see channel-specific SD 55625 \$SCS_MEA_AVERAGE_VALUE[n-1]
- 8) If Y axis is available on the machine

3.1 Overview of measuring cycle parameters

3.1.4 CYCLE976 measuring cycle parameters

```
PROC CYCLE976 (INT S_MVAR, INT S_PRNUM, REAL S_SETV, REAL S_SETV0, INT S_MA, INT S_MD, REAL
S_FA, REAL S_TSA, REAL S_VMS, REAL S_STA1, INT S_NMSP, INT S_MCBIT, INT _DMODE, INT _AMODE) SAVE
ACTBLOCNO DISPLOF
```

Table 3- 4 CYCLE976 call parameters ¹⁾

No.	Screen form parameters	Cycle parameters	Meaning
1		S_MVAR	<p>Measuring version (default=1000)</p> <p>Values: UNITS: Calibration on surface, calibration sphere or calibration ring ²⁾ 0 = Length on surface with known setpoint 1 = Radius in calibration ring with known diameter (setpoint) and known center point. 2 = Radius in calibration ring with known diameter (setpoint) and an unknown center point 3 = Radius and length at the calibration ball 4 = Radius at the edge with known setpoint. Note selection of measuring axis and measuring direction. ³⁾</p> <p>TENS: Reserved 0 = 0</p> <p>HUNDREDS: Reserved 0 = 0</p> <p>THOUSANDS: Selection of measuring axis and measuring direction during calibration. 0 = No specification (no selection of the measuring axis and measuring direction required) ⁸⁾ 1 = Specify selection of measuring axis and measuring direction, see S_MA, S_MD (one measuring direction in a measuring axis) 2 = Specify selection of measuring axis, see S_MA (two measuring directions in a measuring axis)</p> <p>TEN THOUSANDS: Determination of the positional deviation (probe skew) ²⁾ 0 = Determine positional deviation of the probe ⁶⁾ 1 = Do not determine positional deviation</p> <p>HUNDRED THOUSANDS: Paraxial calibration or at an angle 0 = Paraxial calibration in the active WCS 1 = Calibration at an angle ⁷⁾</p> <p>ONE MILLION: Determination of tool length during calibration on surface or on sphere 0 = Do not determine tool length 1 = Determine tool length ⁴⁾</p>

3.1 Overview of measuring cycle parameters

No.	Screen form parameters	Cycle parameters	Meaning
2	Icon+ number	S_PRNUM	Number of the field of the probe parameters (not probe number) (default=1)
3		S_SETV	Setpoint
4	Z0	S_SETV0	Setpoint of the length for sphere calibration
5	X / Y / Z	S_MA	Measuring axis (number of the axis) ^{2), 6)} (default=1)
			Values: 1 = 1. Axis of the plane (for G17 X) 2 = 2nd axis of the plane (for G17 Y) 3 = 3rd axis of the plane (for G17 Z)
6	+ -	S_MD	Measuring direction ^{2), 6)}
			Values: 0 = Positive 1 = Negative
7	DFA	S_FA	Measurement path
8	TSA	S_TSA	Safe area
9	VMS	S_VMS	Variable measuring velocity for calibration ²⁾
10	α	S_STA1	Starting angle ^{2), 5)}
11	Measurements	S_NMSP	Number of measurements at the same location ²⁾ (default=1)
12		S_MCBIT	Screen form of the _CBITs or _CHBITs
13		_DMODE	Display mode
			Values: UNITS: Machining plane G17/G18/G19 0 = compatibility, the plane active before the cycle call remains active 1 = G17 (only active in the cycle) 2 = G18 (only active in the cycle) 3 = G19 (only active in the cycle)
14		_AMODE	Alternative mode

- 1) All default values = 0 or marked as default=x
- 2) Display depends on the general SD 54760 \$SNS_MEA_FUNCTION_MASK_PIECE
- 3) For "Radius in the calibration ring" calibration, the diameter and the center point of the ring must be known (four measuring directions).
For "Radius on two edges" calibration, the distance to the edges in the direction of the measuring axis must be known (two measuring directions).
For "Radius on one edge" calibration, the setpoint of the surface must be known.
- 4) Measuring variant only calibration on a surface (length on surface), corrected tool length results from S_MD and S_MA.
- 5) Only for measuring variant "Calibration ring, ... and known center point" (S_MVAR=1xxx02).
- 6) Measuring axis only for measuring variant S_MVAR=0 or =xx1x01 or =xx2x01 or =20000
Measuring variant: "Calibration on a surface" → selection of measuring axis and measuring direction
or on the "Calibration ring, ... and known center point" → selection of an axis direction and selection of measuring axis and measuring direction
or on the "Calibration ring, ... and known center point" → selection of two axis directions and selection of measuring axis
or "Determination of the probe length" → S_MA=3 → 3rd axis of the plane (for G17 Z)
- 7) Measuring version, only calibration in calibration ring or on calibration sphere
For "Calibration on calibration ball", for measuring at an angle, the axis circles around the ball at the equator.
- 8) For "Radius in calibration ring" calibration with unknown center point, four measuring directions in the plane (for G17 +-X +-Y).
For "Length on surface" calibration in minus direction of the tool axis (for G17 -Z).

3.1 Overview of measuring cycle parameters

3.1.5 CYCLE978 measuring cycle parameters

```
PROC CYCLE978 (INT S_MVAR, INT S_KNUM, INT S_KNUM1, INT S_PRNUM, REAL S_SETV, REAL S_FA, REAL
S_TSA, INT S_MA, INT S_MD, INT S_NMSP, STRING[32] S_TNAME, INT S_DLNUM, REAL S_TZL, REAL
S_TDIF, REAL S_TUL, REAL S_TLL, REAL S_TMV, INT S_K, INT S_EVNUM, INT S_MCBIT, INT _DMODE, INT
_AMODE) SAVE ACTBLOCNO DISPLOF
```

Table 3- 5 CYCLE978 call parameters ¹⁾

No.	Screen form parameters	Cycle parameters	Meaning
1		S_MVAR	Measuring version
			Values: UNITS: Contour element 0 = Measure surface
			TENS: Reserved
			HUNDREDS: Correction target 0 = Only measurement (no correction of the WO or no tool offset) 1 = Measurement, determination and correction of the WO (see S_KNUM) 2 = Measurement and tool offset (see S_KNUM1)
			THOUSANDS: Reserved
			TEN THOUSANDS: Measurement with/without spindle reversal or align measuring probe in the switching direction ⁹⁾ 0 = Measurement without spindle reversal, without probe alignment 1 = Measurement with spindle reversal 2 = Align probe in switching direction
2	Selection	S_KNUM	Correction of the work offset (WO) or basic WO or basic reference ²⁾
			Values: UNITS:
			TENS: 0 = No correction 1 to max. 99 numbers of the work offset or 1 to max. 16 numbers of the basic offset
			HUNDREDS: Reserved
			THOUSANDS: Correction of WO or basic or basic reference 0 = Correction of the adjustable WO 1 = Correction of the channel-specific basic WO 2 = Correction of the basic reference 3 = Correction of the global basic WO 9 = Correction of the active WO or for G500 in last active channel-specific basic WO
			TEN THOUSANDS: Coarse or fine correction in the WO, basic WO or basic reference 0 = Fine correction ⁶⁾ 1 = Coarse correction
3	Selection	S_KNUM1	Correction in tool offset ²⁾
			Values: UNITS:
			TENS:

3.1 Overview of measuring cycle parameters

No.	Screen form parameters	Cycle parameters	Meaning
			<p>HUNDREDS: 0 = No correction 1 to max. 999 D numbers (cutting edge numbers) for tool offset, for additive and setup offset, see also S_DLNUM</p> <p>THOUSANDS: 0 or unique D numbers</p> <p>TEN THOUSANDS: 0 or unique D numbers 1 to max. 32000, If unique D numbers in MDs have been set up</p> <p>HUNDRED THOUSANDS: Tool offset²⁾ 0 = No specification (offset in tool geometry) 1 = Offset of length L1 2 = Offset of length L2 3 = Offset of length L3 4 = radius offset</p> <p>ONE MILLION: Tool offset²⁾ 0 = No specification (offset of the tool radius wear) 1 = Tool offset, additive offset (AO)⁵⁾ Tool offset value is added to the existing AO 2 = Tool offset, setup offset (SO)⁵⁾ SO (new) = SO (old) + AO (old) offset value, AO (new) = 0 3 = Tool offset, setup offset (SO)⁵⁾ Tool offset value is added to the existing SO 4 = Tool offset, geometry</p> <p>TEN MILLION: Tool offset²⁾ 0 = No specification (offset in tool geometry normal, not inverted) 1 = Offset inverted</p>
4	Icon+ number	S_PRNUM	Number of the field of the probe parameter (not probe number) (value range 1 to 12)
5	X0	S_SETV	Setpoint
6	DFA	S_FA	Measurement path
7	TSA	S_TSA	Safe area
8	X	S_MA	<p>Number of the measuring axis ⁷⁾ (value range 1 to 3)</p> <p>Values: 1 = 1st axis of the plane (for G17 X) 2 = 2nd axis of the plane (for G17 Y) 3 = 3rd axis of the plane (for G17 Z) Measurement in tool direction</p>
9		S_MD	<p>Measuring direction of the measuring axis</p> <p>Values: 1 = Positive measuring direction 2 = Negative measuring direction</p>
10	Measurements	S_NMSP	Number of measurements at the same location ²⁾ (value range 1 to 9)
11	TR	S_TNAME	Tool name ³⁾
12	DL	S_DLNUM	Setup additive offset DL number ⁵⁾
13	TZL	S_TZL	Work offset ^{2), 3)}
14	DIF	S_TDIF	Dimensional difference check ^{2), 3)}
15	TUL	S_TUL	Upper tolerance limit ³⁾
16	TLL	S_TLL	Lower tolerance limit ³⁾
17	TMV	S_TMV	Offset range for averaging ²⁾

Parameter lists

3.1 Overview of measuring cycle parameters

No.	Screen form parameters	Cycle parameters	Meaning
18	FW	S_K	Weighting factor for averaging ²⁾
19	EVN	S_EVNUM	Date set, empirical value memory ^{2), 8)}
20		S_MCBIT	Reserved
21		_DMODE	Display mode
			Values: UNITS: Machining plane G17/G18/G19 0 = compatibility, the plane active before the cycle call remains active 1 = G17 (only active in the cycle) 2 = G18 (only active in the cycle) 3 = G19 (only active in the cycle)
22		_AMODE	Alternative mode
			Values: UNITS: Dimensional tolerance yes/no 0 = No 1 = Yes

- 1) All default values = 0 or marked as the range of values a to b
- 2) Display depends on the general SD 54760 \$SNS_MEA_FUNCTION_MASK_PIECE
- 3) Only for offset in tool, otherwise parameter = ""
- 4) Only for offset in tool and dimensional tolerance "Yes", otherwise parameter = 0
- 5) Only if the "Setup additive offset" function has been set-up in the general MD 18108 \$MN_MM_NUM_SUMCORR . In addition, in the general MD 18080 \$MN_MM_TOOL_MANAGEMENT_MASK , bit8 must be set to 1.
- 6) If WO "fine" has not been set up in MDs, correction is according to WO "coarse"
- 7) Offset in tool geometry:
For measurement in the plane (S_MA=1 or S_MA=2) Offset in tool radius
For measurement in tool direction (S_MA=3) Offset in tool length L1
- 8) Empirical averaging for tool offset and correction in WO possible
Value range for empirical mean value memory:
1 to 20 numbers (n) of the empirical value memory, see channel-specific SD 55623 \$SCS_MEA_EMPIRIC_VALUE[n-1]
10000 to 200000 numbers (n) of the mean value memory, see channel-specific SD 55625 \$SCS_MEA_AVERAGE_VALUE[n-1]
- 9) When measuring with spindle reversal, the radius/diameter of the probe must be precisely determined. This should be realized with a calibration version of the CYCLE976 radius at the ring or at the edge or at the ball. Otherwise, the measurement result will be falsified.

3.1.6 CYCLE998 measuring cycle parameters

```
PROC CYCLE998 (INT S_MVAR, INT S_KNUM, INT S_RA, INT S_PNUM, REAL S_SETV, REAL S_STA1, REAL
S_INCA, REAL S_FA, REAL S_TSA, INT S_MA, INT S_MD, REAL S_ID, REAL S_SETV0, REAL S_SETV1, REAL
S_SETV2, REAL S_SETV3, INT S_NMSP, INT S_MCBIT, INT _DMODE, INT _AMODE) SAVE ACTBLOCNO DISPLOF
```

Table 3- 6 CYCLE998 call parameters ¹⁾

No.	Screen form parameters	Cycle parameters	Meaning
1		S_MVAR	Measuring variant (default=5)
			Values: UNITS: Contour element 5 = Measure edge (one angle) 6 = Measure plane (two angles)
			TENS: Reserved
			HUNDREDS: Correction target 0 = Only measurement and no correction of WO 1 = Measurement, determination and correction of the WO (see S_KNUM)
			THOUSANDS: Protection zone 0 = No consideration of a protection zone 1 = Consideration of a protection zone
			TEN THOUSANDS: Measurement with spindle reversal (difference measurement) 0 = Measurement without spindle reversal 1 = Measurement with spindle reversal
			HUNDRED THOUSANDS: Measurement at an angle or paraxial 0 = Measurement at an angle 1 = Measurement paraxial
2	Selection	S_KNUM	Correction of the work offset (WO) or basic WO or basic reference ²⁾
			Values: UNITS:
			TENS: 0 = No correction 1 to max. 99 numbers of the work offset or 1 to max. 16 numbers of the basic offset
			HUNDREDS: Reserved
			THOUSANDS: Correction of WO or basic or basic reference 0 = Correction adjustable WO 1 = correction, channel-specific basic WO 2 = correction basic reference 9 = Correction active WO and/or for G500 in last active channel-specific basic WO
			TEN THOUSANDS: Coarse or fine correction in the WO or basic WO or basic reference ³⁾ 0 = Fine correction 1 = Coarse correction

Parameter lists

3.1 Overview of measuring cycle parameters

No.	Screen form parameters	Cycle parameters	Meaning
3	A, B, C	S_RA	Correction target coordinate rotation or rotary axis
			Values: 0 = Correction target coordinate rotation around the axis that results from parameter S_MA ⁴⁾ >0 = Correction target rotary axis. Number of the channel axis number of the rotary axis (preferably rotary table). The angle offset is made in the translatory part of the WO of the rotary axis.
4	Icon+ number	S_PRNUM	Number of the field of the probe parameter (default=1)
5	DX / DY / DZ	S_SETV	Distance (incremental) from the starting position to measuring point P1 of the measuring axis (S_MA) ⁵⁾
6	α	S_STA1	Angle setpoint for "Align edge" or for "Align plane" around the 1st axis of the plane (for G17 X) ⁹⁾
7	β	S_INCA	Angle setpoint for "Align plane" around the 2nd axis of the plane (for G17 Y) ⁹⁾
8	DFA	S_FA	Measurement path
9	TSA	S_TSA	Safe area Monitoring of the angle difference to the angle setpoint [degrees] ⁶⁾
10	X / Y / Z	S_MA	Measuring axis, offset axis ⁷⁾ (default=201)
			Values: UNITS: Number of the measuring axis 1 = 1st axis of the plane (for G17 X) 2 = 2nd axis of the plane (for G17 Y) 3 = 3rd axis of the plane (for G17 Z)
			TENS: Reserved
			HUNDREDS: Number of the offset axis 1 = 1st axis of the plane (for G17 X) 2 = 2nd axis of the plane (for G17 Y) 3 = 3rd axis of the plane (for G17 Z)
11	+-	S_MD	Measuring direction of the measuring axis ⁸⁾
			Values: 0 = Measuring direction is determined from the setpoint and the actual position of the measuring axis (compatibility) 1 = Positive measuring direction 2 = Negative measuring direction
12	L2	S_ID	For measuring version "Align edge": Distance (incremental) between the measuring points P1 and P2 in the offset axis (value >0) For measuring version "Align plane", the parameters listed below apply.
13	L2	S_SETV0	Distance between the measuring points P1 and P2 in the 1st axis of the plane ¹⁰⁾
14		S_SETV1	Distance between the measuring points P1 and P2 in the 2nd axis of the plane ^{11), 12)}
15	L3x	S_SETV2	Distance between the measuring points P1 and P3 in the 1st axis of the plane ¹¹⁾
16	L3y	S_SETV3	Distance between the measuring points P1 and P3 in the 2nd axis of the plane ¹⁰⁾
17	Measurements	S_NMSP	Number of measurements at the same location ²⁾ (default=1)
18		S_EVNUM	Date set, empirical value memory ^{2), 13)}

No.	Screen form parameters	Cycle parameters	Meaning
19		_DMODE	Display mode
			Values: UNITS: Machining plane G17/G18/G19 0 = Compatibility, the plane active before the cycle call remains active 1 = G17 (only active in the cycle) 2 = G18 (only active in the cycle) 3 = G19 (only active in the cycle)
20		_AMODE	Reserved (alternative mode)

- 1) All default values = 0 or marked as default=x
- 2) Display depends on the general SD 54760 \$SNS_MEA_FUNCTION_MASK_PIECE
- 3) WO "fine" only if correction target is rotary axis and MD 52207 \$MCS_AXIS_USAGE_ATTRIB[n] Bit6=1.
If WO has not been set up in MDs, correction is according to WO "coarse".
- 4) Example for offset in coordinate rotation: S_MA=102 Measuring axis Y, offset axis X results in coordinate rotation around Z (for G17)
- 5) Value only relevant for protection zone "Yes" (S_MVAR THOUSANDS position = 1)
- 6) When positioning from measuring point P1 to measuring point P2 in the offset axis, the angles in parameters S_STA1 and S_TSA are added.
- 7) Number of the measuring axis must not be the same as the number of the offset axis (e.g. 101 not permitted)
- 8) Measuring direction only for "Align edge" and "Measurement paraxial" (S_MVAR=10x105)
- 9) Angular range S_STA1 ±45 degrees for "Align edge"
Angular range S_STA1 0 to +60 degrees and S_INCA ±30 degrees for "Align plane"
- 10) For measuring versions "Align plane" and "Align edge"
- 11) For measuring variant "Measure plane" and "Measurement paraxial"
- 12) Not for measuring cycle version SW04.04.
- 13) Experience value generation for correction in WO; value range of empirical values mean value memory:
1 to 20 numbers(n) of the empirical value memory, see channel-specific SD 55623 \$SCS_MEA_EMPIRIC_VALUE[n-1]

3.1 Overview of measuring cycle parameters

3.1.7 CYCLE977 measuring cycle parameters

```
PROC CYCLE977 (INT S_MVAR, INT S_KNUM, INT S_KNUM1, INT S_PRNUM, REAL S_SETV, REAL S_SETV0, REAL
S_SETV1, REAL S_FA, REAL S_TSA, REAL S_STA1, REAL S_ID, REAL S_SZA, REAL S_SZO, INT S_MA, INT
S_NMSP, STRING[32] S_TNAME, INT S_DLNUM, REAL S_TZL, REAL S_TDIF, REAL S_TUL, REAL S_TLL, REAL
S_TMV, INT S_K, INT S_EVNUM, INT S_MCBIT, INT _DMODE, INT _AMODE) SAVE ACTBLOCNO DISPLOF
```

Table 3-7 CYCLE977 call parameters ¹⁾

No.	Screen form parameters	Cycle parameters	Meaning	
1		S_MVAR	Measuring version	
			Values:	UNITS: Contour element (value range 1 to 6) 1 = Measure hole 2 = Measure spigot (shaft) 3 = Measure groove 4 = Measure rib 5 = Measure rectangle, inside 6 = Measure rectangle, outside
				TENS: Reserved
				HUNDREDS: Correction target 0 = Only measurement (no correction of the WO or no tool offset) 1 = Measurement, determination and correction of the WO (see S_KNUM) 2 = Measurement and tool offset (see S_KNUM1)
				THOUSANDS: Protection zone 0 = No consideration of a protection zone 1 = Consideration of a protection zone
				TEN THOUSANDS: Measurement with/without spindle reversal (differential measurement) or align measuring probe in the switching direction 0 = Measurement without spindle reversal, do not align probe 1 = Measurement with spindle reversal 2 = Align probe in switching direction
2	Selection	S_KNUM	Correction of the work offset (WO) or basic WO or basic reference ²⁾	
			Values:	UNITS: TENS: 0 = No correction 1 to max. 99 numbers of the work offset or 1 to max. 16 numbers of the basic offset
				HUNDREDS: Reserved
				THOUSANDS: Correction of WO or basic or basic reference 0 = Correction of the adjustable WO 1 = Correction of the channel-specific basic WO 2 = Correction of the basic reference 3 = Correction of the global basic WO 9 = Correction of the active WO or for G500 in last active channel-specific basic WO
				TEN THOUSANDS: Coarse or fine correction in the WO, basic WO or basic reference 0 = Fine correction ⁶⁾ 1 = Coarse correction

3.1 Overview of measuring cycle parameters

No.	Screen form parameters	Cycle parameters	Meaning
3	Selection	S_KNUM1	Correction in tool offset ²⁾
			Values:
			UNITS:
			TENS:
			HUNDREDS: 0 = No correction 1 to max. 999 D numbers (cutting edge numbers) for tool offset; for additive and setup offset, see also S_DLNUM
			THOUSANDS: 0 or unique D numbers
			TEN THOUSANDS: 0 or unique D numbers 1 to max. 32000, If unique D numbers in MDs have been set up
			HUNDRED THOUSANDS: Tool offset ²⁾ 0 = No specification (offset tool radius) 1 = Offset of length L1 2 = Offset of length L2 3 = Offset of length L3 4 = radius offset
ONE MILLION: Tool offset ²⁾ 0 = No specification (offset of the tool radius wear) 1 = Tool offset, additive offset (AO) ⁵⁾ Tool offset value is added to the existing AO 2 = Tool offset, setup offset (SO) ⁵⁾ SO (new) = SO (old) + AO (old) offset value, AO (new) = 0 3 = Tool offset, setup offset (SO) ⁵⁾ Tool offset value is added to the existing SO 4 = Tool offset, geometry			
TEN MILLION: Tool offset ²⁾ 0 = No specification (offset in tool geometry normal, not inverted) 1 = Offset inverted			
4	Icon+ number	S_PRRNUM	Number of the field of the probe parameter (not probe number) (value range 1 to 12)
5	X0	S_SETV	Setpoint
6	X0	S_SETV0	Setpoint for rectangle in 1st axis of the plane (X for G17)
7	Y0	S_SETV1	Setpoint for rectangle in 2nd axis of the plane (Y for G17)
8	DFA	S_FA	Measurement path
9	TSA	S_TSA	Safe area
10	α 0	S_STA1	Starting angle
11		S_ID	Absolute incremental value 1. Incremental infeed of the 3rd axis of the plane (Z for G17) Infeed direction via sign of S_ID. For measurement of spigot, rib and rectangle outside, S_ID is used to define the lowering to measuring height. 2. Consideration of a protection zone For measurement of hole, groove and rectangle inside and a protection zone, S_ID is used to define the overtravel height.
12	X1	S_SZA	Diameter or length (width) of the protection zone ⁷⁾
13	Y1	S_SZO	For "Measure rectangle": Width of the protection zone of the 2nd axis of the plane

Parameter lists

3.1 Overview of measuring cycle parameters

No.	Screen form parameters	Cycle parameters	Meaning
14	X	S_MA	Number of the measuring axis ⁷⁾ (only for measurement of groove or rib, see BMVAR UNITS position)
			Values: 1 = 1st axis of the plane (for G17 X) 2 = 2nd axis of the plane (for G17 Y)
15	Measurements	S_NMSP	Number of measurements at the same location ²⁾ (value range 1 to 9)
16	TR	S_TNAME	Tool name ²⁾
17	DL	S_DLNUM	Setup additive offset DL number ⁵⁾
18	TZL	S_TZL	Work offset ^{2), 4)}
19	DIF	S_TDIF	Dimensional difference check ^{2), 4)}
20	TUL	S_TUL	Upper tolerance limit ⁴⁾
21	TLL	S_TLL	Lower tolerance limit ⁴⁾
22	TMV	S_TMV	Offset range for averaging ²⁾
23	FW	S_K	Weighting factor for averaging ²⁾
24		S_EVNUM	Data set, empirical mean value memory ^{2), 8)}
25		S_MCBIT	Reserved
26		_DMODE	Display mode
			Values: UNITS: Machining plane G17/G18/G19 0 = Compatibility, the plane active before the cycle call remains active 1 = G17 (only active in the cycle) 2 = G18 (only active in the cycle) 3 = G19 (only active in the cycle)
27		_AMODE	Alternative mode
			Values: UNITS: Dimensional tolerance yes/no 0 = No 1 = Yes

- 1) All default values = 0 or marked as the range of values a to b
- 2) Display depends on the general SD 54760 \$SNS_MEA_FUNCTION_MASK_PIECE
- 3) Only for offset in tool, otherwise parameter = ""
- 4) Only for offset in tool and dimensional tolerance "Yes", otherwise parameter = 0
- 5) Only if the "Setup additive offset" function has been set-up in the general MD 18108 \$MN_MM_NUM_SUMCORR. In addition, in the general MD 18080 \$MN_MM_TOOL_MANAGEMENT_MASK, bit8 must be set to 1.
- 6) If WO "fine" has not been set up in MDs, correction is according to WO "coarse"
- 7) Diameter or width of the protection zone within a hole or groove
Diameter or width of the protection zone outside of a spigot or rib
- 8) Empirical averaging possible for tool offset
Value range for empirical mean value memory:
1 to 20 numbers (n) of the empirical value memory, see channel-specific SD 55623 \$SCS_MEA_EMPIRIC_VALUE[n-1]
10000 to 200000 numbers (n) of the mean value memory, see channel-specific SD 55625 \$SCS_MEA_AVERAGE_VALUE[n-1]

3.1.8 CYCLE961 measuring cycle parameters

```
PROC CYCLE961 (INT S_MVAR, INT S_KNUM, INT S_PRNUM, REAL S_SETV0, REAL S_SETV1, REAL
S_SETV2, REAL S_SETV3, REAL S_SETV4, REAL S_SETV5, REAL S_SETV6, REAL S_SETV7, REAL S_SETV8, REAL
S_SETV9, REAL S_STA1, REAL S_INCA, REAL S_ID, REAL S_FA, REAL S_TSA, INT S_NMSP, INT S_MCBIT, INT
_DMODE, INT _AMODE) SAVE ACTBLOCNO DISPLOF
```

Table 3- 8 CYCLE961 call parameters ¹⁾

No.	Screen form parameters	Cycle parameters	Meaning	
1		S_MVAR	Measuring version (default ≥ 6)	
			Values:	UNITS: Contour element 5 = Setup of right-angled inside corner, setpoint specification of angle and distances A1 to A3 6 = Setup of right-angled outside corner, setpoint specification of angle and distances A1 to A3 7 = Setup of inside corner, specification of angle and distances A1 to A4 8 = Setup of outside corner, specification of angle and distances A1 to A3
				TENS: Setpoint specification as distance or via four points 0 = Setpoint specification as distance (polar) 1 = Setpoint specification via four points (measuring points P1 to P4)
				HUNDREDS: Correction target 0 = Only measurement (no correction of WO or no tool offset) 1 = Measurement, determination and correction of the WO, see S_KNUM
				THOUSANDS: Protection zone 0 = No consideration of a protection zone (obstacle) 1 = Consideration of a protection zone (obstacle), see S_ID
				TEN THOUSANDS: Position of the corner in the WCS 0 = Position of the corner is determined via parameter S_STA1 (compatibility) 1 = Position 1 of the corner in the positioned starting point of the measurement 2 = Position 2 of the corner, distances in the 1st axis of the plane (for G17 X) are negative (see S_SETV0, S_SETV1) 3 = Position 3 of the corner, distances in the 1st and 2nd axis of the plane (for G17 XY) are negative (see S_SETV0 to S_SETV3) 4 = Position 4 of the corner, distances in the 2nd axis of the plane (for G17 Y) are negative (see S_SETV2, S_SETV3)
2	Selection	S_KNUM	Correction of the work offset (WO) or basic WO or basic reference ²⁾	
			Values:	UNITS: TENS: 0 = No correction 1 to max. 99 numbers of the work offset or 1 to max. 16 numbers of the basic offset
				HUNDREDS: Reserved
				THOUSANDS: Correction of WO or basic or basic reference 0 = Correction adjustable WO 1 = correction, channel-specific basic WO 2 = correction basic reference 9 = Correction active WO and/or for G500 last active channel-specific basic WO

Parameter lists

3.1 Overview of measuring cycle parameters

No.	Screen form parameters	Cycle parameters	Meaning
			TEN THOUSANDS: Coarse or fine correction in the WO, basic WO or basic reference 0 = Fine correction ⁵⁾ 1 = Coarse correction
3	Icon+ number	S_PRNUM	Number of the field of the probe parameter (not probe number) (value range 1 to 12)
4	L1/X1	S_SETV0	Distance L1 between the pole and measuring point P1 in the direction of the 1st axis of the plane (for G17 X) ³⁾ (if the actual distance L1=0, then L1 = M_SETV1 / 2 is automatically calculated) or starting point P1x of the 1st axis of the plane (for G17 X) ⁴⁾
5	L2/Y1	S_SETV1	Distance L2 between the pole and measuring point P2 in the direction of the 1st axis of the plane ³⁾ or starting point P1y of the 2nd axis of the plane (for G17 Y) ⁴⁾
6	L3/X2	S_SETV2	Distance L3 between the pole and measuring point P3 in the direction of the 2nd axis of the plane ³⁾ (if the distance L3=0, then for a corner that is not right angled, L3 = M_SETV3 / 2 is automatically calculated) or starting point P2x of the 1st axis of the plane ⁴⁾
7	L4/Y2	S_SETV3	Distance L4 between the pole and measuring point P3 in the direction of the 2nd axis of the plane with a corner that is not right angled ³⁾ or starting point P2y of the 2nd axis of the plane ⁴⁾
8	XP/X3	S_SETV4	Position of the pole in the 1st axis of the plane ³⁾ or starting point P3x of the 1st axis of the plane ⁴⁾
9	XP/Y3	S_SETV5	Position of the pole in the 2nd axis of the plane ³⁾ or starting point P3y of the 2nd axis of the plane ⁴⁾
10	X4	S_SETV6	Starting point P4x of the 1st axis of the plane ⁴⁾
11	Y4	S_SETV7	Starting point P4y of the 2nd axis of the plane ⁴⁾
12	X0	S_SETV8	Setpoint of the measured corner in the 1st axis of the plane for correcting in WO
13	Y0	S_SETV9	Setpoint of the measured corner in the 2nd axis of the plane for correcting in WO
14	α0	S_STA1	Starting angle from the positive direction of the 1st axis of the plane to the reference edge of the workpiece in the MCS (+-270 degrees)
15	α1	S_INCA	Angle between workpiece reference edges when measuring a non-right-angled corner ⁷⁾
16	DZ	S_ID	Infeed amount at the measuring height for each measuring point for active protection zone (see S_MVAR).
17	DFA	S_FA	Measurement path
18	TSA	S_TSA	Safe area Monitoring of the angle difference to the angle setpoint [degrees] ⁶⁾
19	Measurements	S_NMSP	Number of measurements at the same location ²⁾ (value range 1 to 9) ²⁾
20		S_MCBIT	Reserved
21		_DMODE	Display mode Values: UNITS: Machining plane G17/G18/G19 0 = Compatibility, the plane active before the cycle call remains active 1 = G17 (only active in the cycle) 2 = G18 (only active in the cycle) 3 = G19 (only active in the cycle)

No.	Screen form parameters	Cycle parameters	Meaning
22		_AMODE	Alternative mode

- 1) All default values = 0 or marked as the range of values a to b
- 2) Display depends on the general SD 54760 \$SNS_MEA_FUNCTION_MASK_PIECE
- 3) Input of the measuring points in polar coordinates, taking into account the starting angle S_STA1 for measuring point 3 or 4 of the incremental angle S_INCA .
- 4) Input of the measuring points in the right-angled coordinate system (input using 4 points),
- 5) If WO "fine" has not been set up in MDs, correction is made according to WO "coarse"
- 7) Value range of angle S_INCA : -180 to +180 degrees

3.1 Overview of measuring cycle parameters

3.1.9 CYCLE979 measuring cycle parameters

```
PROC CYCLE979 (INT S_MVAR, INT S_KNUM, INT S_KNUM1, INT S_PRNUM, REAL S_SETV, REAL S_FA, REAL
S_TSA, REAL S_CPA, REAL S_CPO, REAL S_STA1, REAL S_INCA, INT S_NMSP, STRING[32] S_TNAME, REAL
S_DLNUM, REAL S_TZL, REAL S_TDIF, REAL S_TUL, REAL S_TLL, REAL S_TMV, INT S_K, INT S_EVNUM, INT
S_MCBIT, INT _DMODE, INT _AMODE) SAVE ACTBLOCNO DISPLOF
```

Table 3-9 CYCLE979 call parameters ⁰⁾

No.	Screen form parameters	Cycle parameters	Meaning
1		S_MVAR	Measuring version
			Values: UNITS: Contour element 1 = measure hole 2 = measure spigot (shaft)
			TENS: Reserved
			HUNDREDS: Correction target 0 = Only measurement (no correction of the WO or no tool offset) 1 = Measurement, determination and correction of the WO (see S_KNUM) 2 = Measurement and tool offset (see S_KNUM1)
			THOUSANDS: Number of measurement points 0 = 3 measuring points 1 = 4 measuring points
			TEN THOUSANDS: Measurement with/without spindle reversal (differential measurement) or align measuring probe in the switching direction 0 = Measurement without spindle reversal, without probe alignment 1 = Measurement with spindle reversal 2 = Align probe in switching direction
2	Selection	S_KNUM	Correction of the work offset (WO) or basic WO or basic reference ²⁾
			Values: UNITS:
			TENS: 0 = No correction 1 to max. 99 numbers of the work offset or 1 to max. 16 numbers of the basic offset
			HUNDREDS: Reserved
			THOUSANDS: Correction of WO or basic or basic reference 0 = Correction of the adjustable WO 1 = Correction of the channel-specific basic WO 2 = Correction of the basic reference 3 = Correction of the global basic WO 9 = Correction of the active WO or for G500 in last active channel-specific basic WO
			TEN THOUSANDS: Coarse or fine correction in the WO, basic WO or basic reference 0 = Fine correction ⁶⁾ 1 = Coarse correction
3	Selection	S_KNUM1	Correction in tool offset ²⁾
			Values: UNITS:
			TENS:

3.1 Overview of measuring cycle parameters

No.	Screen form parameters	Cycle parameters	Meaning
			<p>HUNDREDS: 0 = No correction 1 to max. 999 D numbers (cutting edge numbers) for tool offset; for additive and setup offset, see also S_DLNUM</p> <p>THOUSANDS: 0 or unique D numbers</p> <p>TEN THOUSANDS: 0 or unique D numbers 1 to max. 32000 if unique D numbers in MDs have been set up</p> <p>HUNDRED THOUSANDS: Tool offset²⁾ 0 = No specification (offset in tool radius) 1 = Offset of length L1 2 = Offset of length L2 3 = Offset of length L3 4 = radius offset</p> <p>ONE MILLION: Tool offset²⁾ 0 = No specification (offset of the tool radius wear) 1 = Tool offset, additive offset (AO)⁵⁾ Tool offset value is added to the existing AO 2 = Tool offset, setup offset (SO)⁵⁾ SO (new) = SO (old) + AO (old) offset value, AO (new) = 0 3 = Tool offset, setup offset (SO)⁵⁾ Tool offset value is added to the existing SO 4 = Tool offset, geometry</p> <p>TEN MILLION: Tool offset²⁾ 0 = No specification (offset in tool geometry normal, not inverted) 1 = Offset inverted</p>
4	Icon+ number	S_PRRNUM	Number of the field of the probe parameter (not probe number) (value range 1 to 12)
5	X0	S_SETV	Setpoint
6	DFA	S_FA	Measurement path
7	TSA	S_TSA	Safe area
8	X0	S_CPA	Center point of the 1st axis of the plane (for G17 X)
9	Y0	S_CPO	Center point of the 2nd axis of the plane (for G17 Y)
10	alpha 0	S_STA1	Starting angle ⁷⁾
11	Alpha 1	S_INCA	Incremental angle ⁸⁾
12	Measurements	S_NMSP	Number of measurements at the same location ¹⁾
13	T	S_TNAME	Tool name ²⁾
14	DL	S_DLNUM	Setup additive offset DL number ^{1), 4)}
15	TZL	S_TZL	Work offset ^{1), 2)}
16	DIF	S_TDIF	Dimensional difference check ^{1), 2)}
17	TUL	S_TUL	Upper tolerance limit ³⁾
18	TLL	S_TLL	Lower tolerance limit ³⁾
19	TMV	S_TMV	Offset range for averaging ¹⁾
20	FW	S_K	Weighting factor for averaging ¹⁾
21		S_EVNUM	Date set, empirical value memory ^{1), 6)}

3.1 Overview of measuring cycle parameters

No.	Screen form parameters	Cycle parameters	Meaning
22		S_MCBIT	Reserved
23		_DMODE	Display mode
			Values: UNITS: Machining plane G17/G18/G19 0 = Compatibility, the plane active before the cycle call remains active 1 = G17 (only active in the cycle) 2 = G18 (only active in the cycle) 3 = G19 (only active in the cycle)
24		_AMODE	Alternative mode
			Values: UNITS: Dimensional tolerance yes/no 0 = No 1 = Yes

- 0) All default values = 0 or marked as the range of values a to b
- 1) Display depends on the general SD 54760 \$SNS_MEA_FUNCTION_MASK_PIECE
- 2) Only for offset in tool, otherwise parameter = ""
- 3) Only for offset in tool and dimensional tolerance "Yes", otherwise parameter = 0
- 4) Only if the "Setup additive offset" function has been set-up in the general MD 18108 \$MN_MM_NUM_SUMCORR.
- 5) If WO "fine" has not been set up in MDs, correction is made according to WO "coarse"
- 6) Empirical averaging only possible for tool offset
Value range for empirical mean value memory:
1 to 20 numbers (n) of the empirical value memory, see channel-specific SD 55623 \$SCS_MEA_EMPIRIC_VALUE[n-1]
10000 to 200000 numbers (n) of the mean value memory, see channel-specific SD 55625 \$SCS_MEA_AVERAGE_VALUE[n-1]
- 7) Value range of starting angle -360 to +360 degrees
- 8) Value range of incremental angle >0 to ≤90 degrees for four measuring points or >0 to ≤120 degrees for three measuring points.

3.1.10 CYCLE997 measuring cycle parameters

```
PROC CYCLE997 (INT S_MVAR,INT S_KNUM,INT S_PRNUM,REAL S_SETV,REAL S_FA,REAL S_TSA,REAL
S_STAL,REAL S_INCA,REAL S_SETV0,REAL S_SETV1,REAL S_SETV2,REAL S_SETV3,REAL S_SETV4,REAL
S_SETV5,REAL S_SETV6,REAL S_SETV7,REAL S_SETV8,REAL S_TNVL,INT S_NMSP,INT S_MCBIT,INT
_DMODE,INT _AMODE) SAVE ACTBLOCNO DISPLOF
```

Table 3- 10 CYCLE997 call parameters ^{1), 2)}

No.	Screen form parameters	Cycle parameters	Meaning
1		S_MVAR	Measuring variant (default =9)
			Values: UNITS: Contour element 9 = Measure sphere
			TENS: Repeat measurement 0 = Without measurement repetition 1 = With measurement repetition
			HUNDREDS: Correction target 0 = Only measurement (no correction of WO) 1 = Measurement, determination and correction of the WO (see S_KNUM)
			THOUSANDS: Measuring strategy 0 = Measurement paraxial, constant alignment of the probe in the switching direction 1 = Measurement at an angle, constant alignment of the probe in the switching direction ³⁾ 2 = Measurement at an angle, align probe in the switching direction ³⁾
			TEN THOUSANDS: Number of spheres to be measured 0 = Measure one sphere 1 = Measure three spheres
			HUNDRED THOUSANDS: Number of measuring points, only for measurement at an angle (note measuring strategy: THOUSANDS position > 0) 0 = Three measuring points for measurement at an angle (traversing around the sphere) 1 = Four measuring points for measurement at an angle (traversing around the sphere)
			MILLIONS: Determination of the diameter setpoint of the sphere 0 = No determination of the diameter setpoint of the sphere 1 = Determination of the diameter setpoint of the sphere
2	Selection	S_KNUM	Correction in work offset (WO) or basic or basic reference ³⁾
			Values: UNITS:
			TENS: 0 = No correction 1 to max. 99 numbers of the work offset or 1 to max. 16 numbers of the basic offset
			HUNDREDS: Reserved

Parameter lists

3.1 Overview of measuring cycle parameters

No.	Screen form parameters	Cycle parameters	Meaning
			<p>THOUSANDS: Correction in WO or basic WO or basic reference 0 = Correction in the adjustable WO 1 = Correction in the channel-specific basic WO 2 = Correction in the basic reference 3 = Correction in the global basic WO ⁷⁾ 9 = Correction in the active WO or for G500 in the last active channel-specific basic WO</p> <p>TEN THOUSANDS: Coarse or fine correction in the WO or basic WO or basic reference 0 = Fine correction ⁶⁾ 1 = Coarse correction</p>
3	Icon+ number	S_PRNUM	Number of the field of the probe parameter (not probe number) (value range 1 to 12)
4		S_SETV	Diameter of the sphere(s) ⁴⁾
5	DFA	S_FA	Measurement path
6	TSA	S_TSA	Safe area
7	Alpha 0	S_STA1	Starting angle for measurement at an angle
8	Alpha 1	S_INCA	Incremental angle for measurement at an angle
9	X1	S_SETV0	Position setpoint of the 1st sphere of the 1st axis of the plane (for G17 X) for 3 sphere measurement
10	Y1	S_SETV1	Position setpoint of the 1st sphere of the 2nd axis of the plane (for G17 Y) for 3 sphere measurement
11	Z1	S_SETV2	Position setpoint of the 1st sphere of the 3rd axis of the plane (for G17 Z) for 3 sphere measurement
12	X2	S_SETV3	Position setpoint of the 2nd sphere of the 1st axis of the plane for 3 sphere measurement
13	Y2	S_SETV4	Position setpoint of the 2nd sphere of the 2nd axis of the plane for 3 sphere measurement
14	Z2	S_SETV5	Position setpoint of the 2nd sphere of the 3rd axis of the plane for 3 sphere measurement
15	X3	S_SETV6	Position setpoint of the 3rd sphere of the 1st axis of the plane for 3 sphere measurement
16	Y3	S_SETV7	Position setpoint of the 3rd sphere of the 2nd axis of the plane for 3 sphere measurement
17	Z3	S_SETV8	Position setpoint of the 3rd sphere of the 3rd axis of the plane for 3 sphere measurement
18	TNVL	S_TNVL	Limit value for distortion of the triangle (sum of the deviations) for 3 sphere measurement ⁵⁾
19	Measurements	S_NMSP	Number of measurements at the same location ²⁾ (value range 1 to 9)
20		S_MCBIT	Reserved
21		_DMODE	<p>Display mode</p> <p>Values: UNITS: Machining plane G17/G18/G19 0 = compatibility, the plane active before the cycle call remains active 1 = G17 (only active in the cycle) 2 = G18 (only active in the cycle) 3 = G19 (only active in the cycle)</p>

No.	Screen form parameters	Cycle parameters	Meaning
22		_AMODE	Alternative mode

- 1) All default values = 0 or marked as the range of values a to b
- 2) Display depends on the general SD 54760 \$SNS_MEA_FUNCTION_MASK_PIECE
- 3) Intermediate positioning, circling around the ball at the equator
- 4) 3 sphere measurement: The same diameter setpoint applies for all three spheres (_SETV)
- 5) Default value for S_TNVL=1.2
Correction in WO: Correction is only performed in the WO when the determined distortion is below the S_TNVL limit value.
- 6) If WO "fine" has not been set up in MDs, correction is according to WO "coarse"
- 7) For measuring variant "Measure three spheres", correction in a global basic frame is not possible (S_KNUM = 3001 to 3016), as the frame does not have a rotation component.

3.1 Overview of measuring cycle parameters

3.1.11 CYCLE995 measuring cycle parameters

```
PROC CYCLE995 (INT S_MVAR,INT S_KNUM,INT S_PRNUM,REAL S_SETV,REAL S_FA,REAL S_TSA,REAL
S_STA1,REAL S_INCA,REAL S_DZ,REAL S_SETV0,REAL S_SETV1,REAL S_SETV2,REAL S_TUL,REAL
S_TZL,INT S_NMSP,INT S_MCBIT,INT _DMODE,INT _AMODE) SAVE ACTBLOCNO DISPLOF
```

Table 3- 11 CYCLE995 call parameters ¹⁾

No.	Screen form parameters	Cycle parameters	Meaning
1		S_MVAR	Measuring variant (default=5)
			Values: UNITS: Contour element 5 = Spindle geometry (parallel to the tool axis)
			TENS: Repeat measurement 1 = with repeat measurement
			HUNDREDS: No offset target 0 = measurement only
			THOUSANDS: Measuring strategy 2 = measurement at an angle, align measuring probe in direction of switching
			TEN THOUSANDS: Number of spheres to be measured 0 = measure a sphere
			HUNDRED THOUSANDS: Number of measurement points 1 = 4 measurement points when measuring at an angle (circle the sphere)
			ONE MILLION: Determination of the diameter setpoint of the sphere 0 = No determination of the diameter setpoint of the sphere 1 = Determination of the diameter setpoint of the sphere
2	Selection	S_KNUM	Correction target 0 = 0
3	Icon+ number	S_PRNUM	Number of the field of the probe parameter (not probe number) (value range 1 to 12)
4	DM	S_SETV	Diameter of the calibration ball ⁴⁾
5	DFA	S_FA	Measurement path
6	TSA	S_TSA	Safe area ⁵⁾
7	alpha 0	S_STA1	Starting angle for measurement at an angle ³⁾
8		S_INCA	Incremental angle for measurement at an angle ²⁾
9	DZ	S_DZ	Distance 1st measurement P1 to the 2nd measurement P2 after the shaft of the probe
10		S_SETV0	Setpoint position of the ball of the 1st axis of the plane (for G17 X) ²⁾
11		S_SETV1	Setpoint position of the ball of the 2nd axis of the plane (for G17 Y) ²⁾
12		S_SETV2	Setpoint position of the ball of the 3rd axis of the plane (for G17 Z) ²⁾
13	TUL	S_TUL	Upper tolerance value of the angle values
14	TZL	S_TZL	Zero offset range ^{1), 4)}
15	Number	S_NMSP	Number of measurements at the same location ²⁾ (value range 1 to 9)
16		S_MCBIT	Reserved ²⁾

No.	Screen form parameters	Cycle parameters	Meaning
17		_DMODE	Display mode
			Values: UNITS: Machining plane G17/G18/G19 0 = compatibility, the plane active before the cycle call remains active 1 = G17 (only active in the cycle) 2 = G18 (only active in the cycle) 3 = G19 (only active in the cycle)
18		_AMODE	Alternative mode
			Values: UNITS: Dimensional tolerance yes/no 0 = No 1 = Yes

All default values = 0 or marked as the range of values a to b

- 1) Display depends on the general SD54760 \$SNS_MEA_FUNCTION_MASK_PIECE
- 2) Parameters are currently not used and also not displayed in the input screen.
The parameter incremental angle s_INCA is permanently set to 90 degrees.
- 3) Value range of starting angle -360 to +360 degrees
- 4) for dimensional tolerance yes:
If the measured angle is less than the value of the work offset range TZL, then the result parameters for the angle ($_OVR[2]$, $_OVR[3]$) and deviations ($_OVR[7]$, $_OVR[8]$) are set to zero.
DisplayTZL is realized using the general SD54760 \$SNS_MEA_FUNCTION_MASK_PIECE bit25=1.
(enable selected zero offset when measuring angularity, spindle)
- 5) Parameter TSA refers to the 1st measurement of the calibration ball.

3.1 Overview of measuring cycle parameters

3.1.12 CYCLE996 measuring cycle parameters

```
PROC CYCLE996 (INT S_MVAR, INT S_TC, INT S_PRNUM, REAL S_SETV, REAL S_STA1, REAL S_SETV0, REAL
S_SETV1, REAL S_SETV2, REAL S_SETV3, REAL S_SETV4, REAL S_SETV5, REAL S_TNVL, REAL S_FA, REAL
S_TSA, INT S_NMSP, INT S_MCBIT, INT _DMODE, INT _AMODE) SAVE SBLOF ACTBLOCNO DISPLOF
```

Table 3- 12 CYCLE996 call parameters ¹⁾

No.	Screen form parameters	Cycle parameters	Meaning
1		S_MVAR	<p>Measurement version (default=1)</p> <p>Values: UNITS: Measuring sequence 0 = Calculate kinematics (selection with: Result display, protocol, change of the swivel data sets, where relevant with operator acknowledgment), see _AMODE 1 = 1st measurement 2 = 2nd measurement 3 = 3rd measurement</p> <p>TENS: Reserved 0 = 0</p> <p>HUNDREDS: Measurement version for 1st to 3rd measurement 0 = Measurement of the calibration ball paraxial 1 = Measurement of the calibration ball at an angle and no spindle correction ³⁾ 2 = Measurement of the calibration ball and correction of the spindle in the switching direction of the probe ³⁾</p> <p>THOUSANDS: Calculate correction target for kinematics ⁴⁾ 0 = measuring only. Swivel data sets are calculated, but remain unchanged 1 = calculate swivel data set. Swivel data sets are, if necessary, changed after acknowledgment by the operator ⁴⁾</p> <p>TEN THOUSANDS: Measuring axis (rotary axis 1 or 2) or vector chain open or closed for calculate kinematics 0 = Vector chain closed (only for calculate kinematics) 1 = Rotary axis 1 (only for 1st to 3rd measurement) 2 = Rotary axis 2 (only for 1st to 3rd measurement) ⁵⁾ 3 = Vector chain open (only for calculate kinematics)</p> <p>HUNDRED THOUSANDS: Normalizing of rotary axis 1 for calculate kinematics 0 = No normalizing of rotary axis 1 1 = Normalizing in direction of 1st axis of the plane (for G17 X) 2 = Normalizing in direction of 2nd axis of the plane (for G17 Y) 3 = Normalizing in direction of 3rd axis of the plane (for G17 Z)</p> <p>ONE MILLION: Normalizing of rotary axis 2 for calculate kinematics ⁵⁾ 0 = No normalizing of rotary axis 2 1 = Normalizing in direction of 1st axis of the plane (for G17 X) 2 = Normalizing in direction of 2nd axis of the plane (for G17 Y) 3 = Normalizing in direction of 3rd axis of the plane (for G17 Z)</p> <p>TEN MILLION: Log file 0 = no protocol file 1 = protocol file with the calculated vectors (tool carrier) and the 1st dynamic 5-axis transformation (TRAORI(1)), if set-up in MDs.</p>

3.1 Overview of measuring cycle parameters

No.	Screen form parameters	Cycle parameters	Meaning
2		S_TC	Number of the swivel data record (tool carrier)
3	Icon+ number	S_PRNUM	Number of the field of the probe parameters (not probe number) (default=1)
4		S_SETV	Diameter of the calibration ball
5	alpha 0	S_STA1	Starting angle for measurement at an angle
6	alpha 0	S_SETV0	Position value of rotary axis 1 (if rotary axis is manual or semi-automatic)
7	alpha 1	S_SETV1	Position value of rotary axis 2 (if rotary axis is manual or semi-automatic) ⁶⁾
8	XN	S_SETV2	Position value for normalizing rotary axis 1
9	XN	S_SETV3	Position value for normalizing of rotary axis 2 ⁶⁾
10	Delta	S_SETV4	Tolerance value of the offset vectors I1 to I4
11	Delta	S_SETV5	Tolerance value of rotary axis vectors V1 and V2
12	alpha 2	S_TNVL	Limit value of angular segment of the rotary axis (value range 1 to 60 degrees) (default=20) ⁷⁾
13	DFA	S_FA	Measurement path
14	TSA	S_TSA	Safe area
15	Measurements	S_NMSP	Number of measurements at the same location ²⁾ (default=1)
16		S_MCBIT	Reserved
17		_DMODE	Display mode Values: UNITS: Machining plane G17/G18/G19 0 = compatibility, the plane active before the cycle call remains active 1 = G17 (only active in the cycle) 2 = G18 (only active in the cycle) 3 = G19 (only active in the cycle)
18		_AMODE	Alternative mode Values: UNITS: Tolerance check yes/no 0 = No 1 = Yes: Evaluation of the tolerance values of the vectors S_SETV4, S_SETV5 TENS: Acknowledgment by the operator when entering the calculated vectors in the swivel data set ⁴⁾ 0 = yes Operator must acknowledge the change 1 = no: calculated vectors are entered immediately (only effective if HUNDREDS and THOUSANDS position = 0) HUNDREDS: Measurement result display ⁵⁾ 0 = No 1 = Yes THOUSANDS: Measurement result display can be edited 0 = no 1 = yes, and can be edited (only effective, if the HUNDREDS position = 1)

3.1 Overview of measuring cycle parameters

No.	Screen form parameters	Cycle parameters	Meaning
-----	------------------------	------------------	---------

- 1) All default values = 0 or marked as default=x
- 2) Display depends on the general SD54760 \$SNS_MEA_FUNCTION_MASK_PIECE
- 3) Using this version, for example, for 90 degree positions, the kinematics can be measured at the calibration ball, without colliding with the retaining shaft of the calibration ball. A starting angle S_STA1 (0 to 360 degrees) can be entered. The incremental angle when circling the ball is equal to 90 degrees.
As feedrate along the circular path, the channel-specific SD55634 \$SCS_MEA_FEED_PLANE_VALUE is used
- 4) There is an operator prompt with M0 before entering. The vectors are only entered with NC start.
If the measuring program is aborted with RESET no calculated vectors are entered.
Vectors are only entered when the tolerance of the offset vectors has not been exceeded during the calculation.
- 5) Measurement result display only for the calculated kinematics measuring version.
If the measurement result should also be displayed after the 1st to the 3rd measurement, then this is realized by setting the channel-specific SD 55613 \$SCS_MEA_RESULT_DISPLAY.
- 6) Rotary axis 2 only for kinematics with two rotary axes
- 7) Limit value angular segment of the rotary axis. Value range of S_TNVL between 20 and 60 degrees. For values of $S_TNVL < 20$ degrees, inaccuracies can be expected as a result of the measuring inaccuracies in the micrometer range of the probe. If the limit value is violated, then error message 61430 is output – with a display of the minimum limit value.

3.1.13 CYCLE982 measuring cycle parameters

```
PROC CYCLE982 (INT S_MVAR, INT S_KNUM, INT S_PRNUM, INT S_MA, INT S_MD, REAL S_ID, REAL S_FA, REAL
S_TSA, REAL S_VMS, REAL S_STA1, REAL S_CORA, REAL S_TZL, REAL S_TDIF, INT S_NMSP, INT S_EVNUM, INT
S_MCBIT, INT _DMODE, INT _AMODE) SAVE ACTBLOCNO DISPLOF
```

Table 3- 13 CYCLE982 call parameters ¹⁾

No.	Screen form parameters	Cycle parameters	Meaning	
1		S_MVAR	Measuring version	
			Values:	UNITS: Calibration/measurement 0 = Calibrate tool probe 1 = Single tool measurement ³⁾ 2 = Multiple tool measurement, determine lengths and tool radius (for milling tools)
				TENS: Calibration or measurement in the MCS or WCS 0 = Machine-related ⁴⁾ 1 = Workpiece-related
				HUNDREDS: Measurement with or without reversal for milling tools 0 = Measurement without reversal 1 = Measurement with reversal
				THOUSANDS: Correction target for milling tools 0 = length or length and radius is/are determined (see S_MVAR 1st position) 1 = radius is determined, if S_MVAR 1st position = 1 2 = length and radius are determined (face side), if S_MVAR 1st position = 1 or 23 = disk-type milling tool, upper cutting edge (rear side) and length and radius are determined ⁵⁾
				TEN THOUSANDS: Position of the milling tool or the drill 0 = Axial position of the milling tool or the drill, radius in 2nd axis of the plane (for G18 X) ⁷⁾ 1 = Radial position of the milling tool or the drill, radius in 1st axis of the plane (for G18 Z) ⁷⁾
				HUNDRED THOUSANDS: Incremental calibration or measurement 0 = No specification 1 = Incremental calibration or measurement
				MILLIONS: Position spindle at starting angle S_STA1 (only for measurement of milling tools) 0 = spindle is not positioned 1 = spindle is positioned at the starting angle S_STA1
2	Selection	S_KNUM	Offset variant ²⁾	
			Values:	UNITS: Tool offset 0 = No specification (tool offset in geometry) 1 = Tool offset in wear
3	Icon+ number	S_PRNUM	Number of the field of the probe parameters (not probe number) (default=1)	
4	X0	S_MA	Measuring axis	
			Values:	1 = 1. Axis of the plane (for G18 Z) 2 = 2nd axis of the plane (for G18 X)

Parameter lists

3.1 Overview of measuring cycle parameters

No.	Screen form parameters	Cycle parameters	Meaning
5	+/-	S_MD	Measuring direction
			Values: 0 = No selection (measuring direction is determined from actual value) 1 = Positive 2 = Negative
6	Z2	S_ID	Offset
7	DFA	S_FA	Measurement path
8	TSA	S_TSA	Safe area
9	VMS	S_VMS	Variable measuring velocity for calibration ²⁾
10	Alpha1	S_STA1	Starting angle when measuring milling tools
11	Alpha2	S_CORA	Offset angle when measuring milling tools with reversal ⁸⁾
12	TZL	S_TZL	Work offset when measuring milling tools When calibrating S_TZL = 0
13	DIF	S_TDIF	Dimension difference check
14	Measurements	S_NMSP	Number of measurements at the same location ²⁾ (default=1)
15	EVN	S_EVNUM	Number of the empirical mean value memory ^{2), 9)}
16		S_MCBIT	Reserved
17		_DMODE	Display mode
			Values: UNITS: Machining plane G17/G18/G19 0 = Compatibility, the plane active before the cycle call remains active 1 = G17 (only active in the cycle) 2 = G18 (only active in the cycle) 3 = G19 (only active in the cycle)
			TENS: Cutting edge position for turning and milling tools (only for display in the input screens 1 to 9)
			HUNDREDS: Tool type 0 = Turning tool 1 = Milling tool 2 = Drill
			THOUSANDS: The approach strategy with reference to the tool probe 0 = PLUS [X/Z]; X if tool position axial, Z if tool position radial 1 = MINUS [X/Z]; X if tool position axial, Z if tool position radial

No.	Screen form parameters	Cycle parameters	Meaning
18		_AMODE	Alternative mode

- 1) All default values = 0 or marked as default=x
- 2) Display depends on the general SD 54762 _MEA_FUNCTION_MASK_TOOL
- 3) Measure turning or milling tool or drill. Measuring axis in parameter S_MA
Specification for turning tools via cutting edge position 1...8, for milling tools via HUNDREDS to THOUSANDS position in parameter S_MVAR.
- 4) Measurement and calibration are performed in the basic coordinate system (MCS for kinematic transformation switched off).
- 5) Not for incremental measuring
- 6) Only for multiple measurements S_MVAR=x2x02or x3x02(example, disk-type or groove milling tools)
- 7) If the channel-specific SD 42950 \$SC_TOOL_LENGTH_TYPE = 2, then the tool length components are assigned just the same as for turning tools
- 8) Only for measurement with reversal S_MVAR=xx1x1
- 9) Empirical value generation
Value range of the empirical value memory: 1 to 20 numbers(n) of the empirical value memory, see channel-specific SD 55623 \$SCS_MEA_EMPIRIC_VALUE[n-1].

3.1 Overview of measuring cycle parameters

3.1.14 CYCLE971 measuring cycle parameters

```
PROC CYCLE971 (INT S_MVAR, INT S_KNUM, INT S_PRNUM, INT S_MA, INT S_MD, REAL S_ID, REAL S_FA, REAL
S_TSA, REAL S_VMS, REAL S_TZL, REAL S_TDIF, INT S_NMSP, REAL S_F1, REAL S_S1, REAL S_F2, REAL
S_S2, REAL S_F3, REAL S_S3, INT S_EVNUM, INT S_MCBIT, INT _DMODE, INT _AMODE) SAVE DISPLOF
```

Table 3- 14 CYCLE971 call parameters ¹⁾

No.	Screen form parameters	Cycle parameters	Meaning
1		S_MVAR	Measuring version
			Values: UNITS: 0 = Calibrate tool probe 1 = Measure tool with stationary spindle (length or radius) 2 = Measure tool with rotating spindle (length or radius), see parameters S_F1 to S_S4
			TENS: Measurement in the machine coordinate system or workpiece coordinate system 0 = Measurement in MCS (machine-related), measure tool or calibrate tool probe 1 = Measurement in WCS (workpiece-related), measure tool or calibrate tool probe
			HUNDREDS: Single cutting edge measurement of milling tools 0 = No 1 = Yes
			THOUSANDS: 0 = 0
			TEN THOUSANDS: 0 = 0
			HUNDRED THOUSANDS: Calibrate tool probe automatically 0 = Do not calibrate tool probe automatically 1 = Calibrate tool probe automatically
			ONE MILLION: Calibrating in the plane with spindle reversal 0 = Calibrating in the level without spindle reversal 1 = calibrating in the plane with spindle reversal
2	Selection	S_KNUM	Offset variant ²⁾
			Values: UNITS: Tool offset 0 = No specification (tool offset in geometry) 1 = Tool offset in wear
3	Icon+ number	S_PRNUM	Number of the field of the probe parameters (not probe number)
4	X0	S_MA	Measuring axis, offset axis ⁴⁾
			Values: UNITS: Number of the measuring axis 1 = 1st axis of the plane (for G17 X) 2 = 2nd axis of the plane (for G17 Y) 3 = 3rd axis of the plane (for G17 Z) TENS: 0 = 0

3.1 Overview of measuring cycle parameters

No.	Screen form parameters	Cycle parameters	Meaning
			HUNDREDS: Number of the offset axis 0 = no offset axis 1 = 1st axis of the plane (for G17 X) 2 = 2nd axis of the plane (for G17 Y)
5	+ -	S_MD	Measuring direction Values: 0 = No selection (measuring direction is determined from actual value) 1 = Positive 2 = Negative
6	Z2	S_ID	Offset Values: 0 = For tools without offset >0 = <ul style="list-style-type: none"> Calibration: The offset is applied to the 3rd axis of the plane (for G17 Z) if the diameter of the calibration tool is greater than the upper diameter of the probe. The tool is offset by the tool radius from the center of the probe, minus the value of S_ID. The offset axis is also specified in S_MA . Measure: With multiple cutting edges, the offset of tool length and the highest point of the cutting edge must be specified for radius measurement or the offset of tool radius to the highest point of the cutting edge must be specified when measuring the length.
7	DFA	S_FA	Measurement path
8	TSA	S_TSA	Safe area
9	VMS	S_VMS	Variable measuring velocity for calibration ²⁾
10	TZL	S_TZL	Work offset (only for tool measurement) ²⁾
11	DIF	S_TDIF	Dimensional difference check for tool measurement (S_MVAR=xx1 or S_MVAR=xx2)
12	Measurements	S_NMSP	Number of measurements at the same location ²⁾
13	F1	S_F1	1st feedrate for contact with rotating spindle ²⁾
14	S1	S_S1	1st speed for contact with rotating spindle ²⁾
15	F2	S_F2	2nd feedrate for contact with rotating spindle ²⁾
16	S2	S_S2	2nd speed for contact with rotating spindle ²⁾
17	F3	S_F3	2nd feedrate for contact with rotating spindle ³⁾
18	S3	S_S3	2nd speed for contact with rotating spindle ³⁾
19	EVN	S_EVNUM	Number of the empirical value memory ²⁾
20		S_MCBIT	Screen form of the _CBITs or _CHBITs
21		_DMODE	Display mode Values: UNITS: Machining plane G17/G18/G19 0 = compatibility, the plane active before the cycle call remains active 1 = G17 (only active in the cycle) 2 = G18 (only active in the cycle) 3 = G19 (only active in the cycle)
22		_AMODE	Alternative mode Values: UNITS: Reserved TENS: Reserved HUNDREDS: Reserved

3.1 Overview of measuring cycle parameters

No.	Screen form parameters	Cycle parameters	Meaning
-----	------------------------	------------------	---------

- 1) All default values = 0 or marked as default=x
- 2) Display depends on the general SD 54762 MEA_FUNCTION_MASK_TOOL
- 3) Only for offset in tool and dimensional tolerance "Yes", otherwise parameter = 0
- 4) For automatic measurement ($S_MVAR=1x00xx$), no display of measuring axis, offset axis $\Rightarrow S_MA=0$.

3.2 Additional parameters

The following supplementary parameters can be hidden or unhidden using setting data in the input screen forms. For more information about setting data SD54760 to SD54764, see the List Manual *SINUMERIK 840D sl, detailed description of the machine data*.



Machine manufacturer

Please observe the machine manufacturer's instructions.

The supplementary parameters are not available for all measuring cycles. See also the interface description.

Table 3- 15 Supplementary parameters for workpiece measurement

Screen form parameters	Transfer parameters	Description	Unit
Calibration data set	S_PRNUM	Number of the data set with the calibrated values of the probe	-
F	S_VMS	Measuring feedrate when calibrating the probe	mm/min
Selection	S_MVAR	Calibrate probe: selection at the known or unknown center point of the calibration ring	-
Selection	S_MVAR	Calibrate probe: selection, calibration with or without position deviation (probe skew)	-
Number	S_NMSP	Number of measurements at the same location	-
TZL	S_TZL	Work offset for correction in a tool	mm
DIF	S_TDIF	Dimension difference monitoring for correction in a tool	-
Data set, mean value generation	S_EVNUM	Generating mean values for correction in a tool	-
Data set, empirical values	S_EVNUM	Generating empirical values for correction in a tool	-
FW	S_K	Weighting factor for averaging	-
TMV	S_TMV	Offset range for averaging	
Selection	S_MVAR	Measuring when turning, diameter inside outside: <ul style="list-style-type: none"> • With reversal • Travel under center of rotation 	-

3.2 Additional parameters

Additional correction options when measuring workpiece:

1. Work offsets
 - Offset in the basic reference
 - Offset in the channel-specific basic WO
 - Offset in the global basic WO
 - Offset, coarse or fine
2. Tool offsets
 - Tool offset in geometry or wear
 - Tool offset, inverted or not inverted
 - Tool offset in radius or length L1 or L2 or L3

Table 3- 16 Supplementary parameter when measuring tool

Screen form parameters	Transfer parameters	Description	Unit
Calibration data set	S_PRNUM	Number of the data set with the calibrated values of the probe	-
F	S_VMS	Measuring feedrate when calibrating the probe	mm/min
Selection, measuring steps	S_MVAR	Input of max. 3 feedrates and 3 spindle speeds when measuring with rotating spindle	-
Selection	S_MVAR	Tool offset in geometry or wear	-
Selection	S_MVAR	Measurement in the machine coordinate system or workpiece coordinate system	-
Number	S_NMSP	Number of measurements at the same location	-
Data set, empirical values	S_EVNUM	Generating empirical values for correction in a tool	-

3.3 Additional result parameters

The following table below contains the additional result parameters for the measuring variants of the tool offset.

Parameters	Description	Unit
_OVR [8] ¹⁾	Upper tolerance limit for: <ul style="list-style-type: none"> • Diameter of hole / circular spigot / circle segment • Measuring axis • Width of groove/rib • Rectangle length in the 1st axis of the plane 	mm
_OVR [9] ^{1), 3)}	Upper tolerance limit for rectangle length in the 2nd axis of the plane	mm
_OVR [12] ¹⁾	Lower tolerance limit for: <ul style="list-style-type: none"> • Diameter of hole / circular spigot / circle segment • Measuring axis • Width of groove/rib • Rectangle length in the 1st axis of the plane 	mm
_OVR [13] ^{1), 3)}	Lower tolerance limit for rectangle length in the 2nd axis of the plane	mm
_OVR [20] ¹⁾	Offset value	mm
_OVR [27] ¹⁾	Work offset range	mm
_OVR [28] ¹⁾	Safe area	mm
_OVR [29] ¹⁾	Dimensional difference	mm
_OVR [30] ¹⁾	Empirical value	mm
_OVR [31] ¹⁾	Mean value	mm
_OVI [4] ¹⁾	Weighting factor	-
_OVI [5]	Probe number	-
_OVI [6] ¹⁾	Mean value memory number	-
_OVI [7] ¹⁾	Empirical value memory number	-
_OVI [8] ¹⁾	Tool number	-
_OVI [9] ¹⁾	Alarm number	-
_OVI [11] ²⁾	Status offset request	-
_OVI [13] ¹⁾	DL number	-

¹⁾ Only for workpiece measurement with tool offset

²⁾ only for correction in the WO

³⁾ Only applies for the measuring versions "Rectangular pocket" and "Rectangular spigot"

3.4 Parameter

Table 3- 17 List of input/output variables for cycles

Screen form parameters	Cycle parameters	Meaning in English	Meaning in German
	S_CALNUM	Calibration groove number	Number of the gauging block
	S_MCBIT	Central Bits	Screen form of the _CBITs or _CHBITs
$\alpha 2$	S_CORA	Correction angle position	Offset angle
X0	S_CPA	Center point abscissa	Center point of the 1st axis of the plane
Y0	S_CPO	Center point ordinate	Center point of the 2nd axis of the plane
DL	S_DLNUM		DL number for setup or additive offset
EVN	S_EVNUM		Number, mean empirical value memory
DFA	S_FA	Factor for multipl. of measurem. path	Measurement path
	S_ID	Infeed in applicate	Incremental infeed absolute value / offset
$\alpha 1$	S_INCA	Indexing angle	Incremental angle / angle setpoint
FW	S_K	Weighting factor for averaging	Weighting factor for averaging
Selection	S_KNUM		Correction WO, basic WO or basic reference
Selection	S_KNUM1		Correction in tool offset
X / Y / Z	S_MA	Number of measuring axis	Measuring axis (number of the axis)
+ / -	S_MD	Measuring direction	Measuring direction
	S_MFS		Feedrate and speed for measurement with rotating spindle
	S_MVAR	Measuring variant	Measuring version
Number	S_NMSP	Number of measurements at same spot	Number of measurements at the same location
	_OVI [20]		Field: Output values INT
	_OVR [32]		Field: Output values REAL
Icon + number	S_PRNUM	Probe type and probe number	Number of the field of the probe parameters
X0 / Y0 / Z0	S_SETV	Setpoint value	Setpoint
$\alpha 1$	S_STA1	Starting angle	Starting angle
X	S_SZA	Safety zone on workpiece abscissa	Protection zone in the 1st axis of the plane
Y	S_SZO	Safety zone on workpiece ordinate	Protection zone in the 2nd axis of the plane
DIF	S_TDIF	Tolerance dimensional difference check	Dimension difference check
TLL	S_TLL	Tolerance lower limit	Tolerance lower limit
TMV	S_TMV		Mean value generation with compensation
T	S_TNAME	Tool name	Tool name when using tool manager
	S_TNVL		Limit value for distortion of the triangle
TSA	S_TSA	Tolerance safe area	Safe area
TUL	S_TUL	Tolerance upper limit	Tolerance upper limit
TZL	S_TZL	Tolerance zero offset range	Work offset
VMS	S_VMS	Variable measuring speed	Variable measuring speed

Changes from cycle version SW4.4 and higher

A.1 Assignment of the measuring cycle parameters to MEA_FUNCTION_MASK parameters

All setting data that were saved up to measuring cycle version 2.6 in GUD variables, from software release SW 4.4 are located in the configurable machine and setting data (e.g. data fields of the calibration values). The GUD modules GUD5, GUD6 and GUD7_MC are no longer required for measuring cycle data.

The following tables include the assignment of function-determining measuring cycle parameters to the MEA_FUNCTION_MASK parameters.

Bit 1)	Function	MD identifier SW 2.6	GUD name up to SW 2.6
General cycle machine data: MD51740 \$MNS_MEA_FUNCTION_MASK (32 bits)			
Workpiece measurement			
0	Calibration monitoring (default = 1)	51616 \$MNS_MEA_CAL_MONITORING	_CBIT[16]
1	Length reference of the probe in the infeed axis (default = 1) 0 = reference point is the center of the probe ball 1 = reference point is the circumference of the probe ball	51614 \$MNS_MEA_PROBE_LENGTH_RELATE	_CBIT[14]
2	Taking into account tool carriers that can be orientated for correction/offset in a tool (default = 0)	51610 \$MNS_MEA_TOOLCARR_ENABLE	_CBIT[7]
3	Offset angle for mono-workpiece probe (default = 1)	51612 \$MNS_MEA_MONO_COR_POS_ACTIVE	_CBIT[8]
Tool measurement			
16	Taking into account tool carriers that can be orientated for correction/offset in a tool (default = 0)	MD 51610 \$MNS_MEA_TOOLCARR_ENABLE	_CBIT[7]
Channel-specific cycle machine data: MD52740 \$MCS_MEA_FUNCTION_MASK (32 bits)			
Workpiece measurement			
0	Measuring input, workpiece probe (default = 0) 0 = CNC measuring input 1 1 = CNC measuring input 2	51606 \$MNS_MEA_INPUT_PIECE_PROBE[0]	_CHBIT[0]
1	Rotating measuring cycles use Y axis as measuring axis (default = 0)	52605 \$MCS_MEA_TURN_CYC_SPECIAL_MODE	_CHBIT[19]
Tool measurement			
16	Measuring input, tool probe (default = 1) 0 = CNC measuring input 1 1 = CNC measuring input 2	51607 \$MNS_MEA_INPUT_TOOL_PROBE[0]	_CHBIT[1]

A.1 Assignment of the measuring cycle parameters to MEA_FUNCTION_MASK parameters

Bit 1)	Function	MD identifier SW 2.6	GUD name up to SW 2.6
General cycle setting data: SD 54740 \$SNS_MEA_FUNCTION_MASK (32 bits)			
Workpiece measurement			
0	Repeating measurement for violation of _TDIF and _TSA (default = 0)	54655 \$SNS_MEA_REPEATE_ACTIVE	_CBIT[0]
1	Repeat measurement with alarm output and cycle stop at M0 (default = 0)	54656 \$SNS_MEA_REPEATE_WITH_M0	_CBIT[1]
2	Violation of _TUL, _TLL, _TDI, Cycle stop at M0 (default = 0)	54657 \$SNS_MEA_TOL_ALARM_SET_M0	_CBIT[2]
3	Accept calibrated probe ball radius in tool data (default = 1)	54660 \$SNS_MEA_PROBE_BALL_RAD_IN_TOA	_CBIT[15]
Tool measurement			
16	Repeating measurement for violation of _TDIF and _TSA (default = 0)	54655 \$SNS_MEA_REPEATE_ACTIVE	_CBIT[0]
17	Repeat measurement with alarm output and cycle stop at M0 (default = 0)	54656 \$SNS_MEA_REPEATE_WITH_M0	_CBIT[1]
18	Violation of _TDIF, Cycle stop at M0 (default = 0)	54657 \$SNS_MEA_TOL_ALARM_SET_M0	_CBIT[2]
19	Milling cutter, spindle speed reduction at the last contact		_CHBIT[22]
Channel-specific setting data: SD 55740 \$SCS_MEA_FUNCTION_MASK (32 bits)			
Workpiece measurement			
0	Collision monitoring (default = 1)	55600 \$SCS_MEA_COLLISION_MONITORING	_CHBIT[2]
1	Coupling of the spindle position, with a coordinate rotation around the infeed axis in AUTOMATIC (default = 0)	55602 \$SCS_MEA_COUPL_SPIND_COORD	_CHBIT[13]
2	Direction of rotation of the spindle positioning, with active coupling of the spindle and coordinate rotation (default = 0) 0 = in the GUZ 1 = in the UZ	55604 \$SCS_MEA_SPIND_MOVE_DIR	_CHBIT[14]
3	Measurement attempts when the probe does not switch (default = 0) 0 = 5 attempts 1 = 1 attempt	55606 \$SCS_MEA_NUM_OF_MEASURE	_CHBIT[15]
4	Approach velocity to the measuring position (default = 0) 0 = with measuring feedrate _VMS 1 = with \$SCS_MEA_FEED_FAST_MEASURE	55610 \$SCS_MEA_FEED_TYP	_CHBIT[17]
5	Retraction velocity from the measuring point (default = 0) 0 = with \$SCS_MEA_FEED_PLANE_VALUE 1 = with \$SCS_MEA_FEED_RAPID_IN_PERCENT	55608 \$SCS_MEA_RETRACTION_FEED	_CHBIT[16]

A.1 Assignment of the measuring cycle parameters to MEA_FUNCTION_MASK parameters

Bit 1)	Function	MD identifier SW 2.6	GUD name up to SW 2.6
6	Activate/deactivate workpiece probe before and after the NC command SPOS. See also CUST_MEA_CYC.SPF (default = 0) 0 = no call CUST_MEA_CYC.SPF 1 = call CUST_MEA_CYC.SPF	-	-
...			
14	Coupling of the spindle position, with a coordinate rotation around the infeed axis when a measuring in JOG (default = 1)	55770 \$SCS_J_MEA_SET_COUPL_SP_COORD	E_MESS_SETT[0]
15	Calibration in the calibration ring when a measuring in JOG (default = 0) 0 = calibrate with automatic reference center point 1 = calibrate with known reference center point	55771 \$SCS_J_MEA_SET_CAL_MODE	E_MESS_SETT[1]
Tool measurement			
16	Collision monitoring (default = 1)	55600 \$SCS_MEA_COLLISION_MONITORING	_CHBIT[2]
17	Measurement attempts when the probe does not switch (default = 0) 0 = 5 attempts 1 = 1 attempt	55606 \$SCS_MEA_NUM_OF_MEASURE	_CHBIT[15]
18	Approach velocity to the measuring position (default = 0) 0 = with measuring feedrate _VMS 1 = with \$SCS_MEA_FEED_FAST_MEASURE	55610 \$SCS_MEA_FEED_TYP	_CHBIT[17]
19	Retraction velocity from the measuring point (default = 0) 0 = with \$SCS_MEA_FEED_PLANE_VALUE 1 = with \$SCS_MEA_FEED_RAPID_IN_PERCENT	55608 \$SCS_MEA_RETRACTION_FEED	_CHBIT[16]

- 1) Bit x=0 means that the function is disabled
Bit x=1 means that the function is enabled
All non-documented bits are not assigned.

A.2 Changes in the machine and setting data from SW 4.4

MD replaced with SD

The following cycle machine data (measuring in JOG) no longer apply from cycle release SW 04.04.01 (compared to SW 02.06.00) and are replaced by the following cycle setting data **that mean the same** .

MDs are no longer required	Replaced by SD
51609 \$MNS_MEA_INPUT_TOOL_PROBE_SUB[0 .. 5]	54652 \$SNS_MEA_INPUT_TOOL_PROBE_SUB[0 .. 5]
51755 \$MNS_J_MEA_MEASURING_FEED	55630 \$SCS_MEA_FEED_MEASURE
51774 \$MNS_J_MEA_T_PROBE_TYPE[n]	54633 \$SNS_MEA_TP_TYPE[n]
51776 \$MNS_J_MEA_T_PROBE_ALLOW_AX_DIR[n]	54632 \$SNS_MEA_TP_AX_DIR_AUTO_CAL[n]
51778 \$MNS_J_MEA_T_PROBE_DIAM_LENGTH[n]	54631 \$SNS_MEA_TP_EDGE_DISK_SIZE[n]
51782 \$MNS_J_MEA_T_PROBE_T_EDGE_DIST[n]	54634 \$SNS_MEA_TP_CAL_MEASURE_DEPTH[n]
51787 \$MNS_J_MEA_T_PROBE_MEASURE_FEED	55628 \$SCS_MEA_TP_FEED_MEASURE

Change, number of the setting data

For the following cycle setting data, from SW 04.04.01, the number of the setting data changes (with respect to cycle release SW 02.06.00). Identifier and function have not changed.

Number SD		Identifier
Release SW 02.06.00	From SW 04.04.01	
54798	54780	\$SNS_J_MEA_FUNCTION_MASK_PIECE
54799	54782	\$SNS_J_MEA_FUNCTION_MASK_TOOL
55630	55632	\$SCS_MEA_FEED_RAPID_IN_PERCENT
55631	55634	\$SCS_MEA_FEED_PLANE_VALUE
55632	55636	\$SCS_MEA_FEED_FEEDAX_VALUE
55633	55638	\$SCS_MEA_FEED_FAST_MEASURE

A.3 Complete overview of the changed cycle machine and cycle setting data

Table A- 1 Complete overview of the changed cycle machine data

SW 02.06.01.03 HF3 CYCLE SW 02.06.56.00	CYCLE SW 04.04.05.00
	N51071 \$MNS_ACCESS_ACTIVATE_CTRL_E
	N51072 \$MNS_ACCESS_EDIT_CTRL_E
	N51073 \$MNS_ACCESS_SET_SOFTKEY_ACCESS
	N51199 \$MNS_ACCESS_WRITE_TM_GRIND
N51606 \$MNS_MEA_INPUT_PIECE_PROBE[0]	
N51606 \$MNS_MEA_INPUT_PIECE_PROBE[1]	
N51607 \$MNS_MEA_INPUT_TOOL_PROBE[0]	
N51607 \$MNS_MEA_INPUT_TOOL_PROBE[1]	
N51609 \$MNS_MEA_INPUT_TOOL_PROBE_SUB[0 .. 5]	
N51610 \$MNS_MEA_TOOLCARR_ENABLE	
N51612 \$MNS_MEA_MONO_COR_POS_ACTIVE	
N51614 \$MNS_MEA_PROBE_LENGTH_RELATE	
N51616 \$MNS_MEA_CAL_MONITORING	
	N51740 \$MNS_MEA_FUNCTION_MASK'
N51755 \$MNS_J_MEA_MEASURING_FEED	
N51774 \$MNS_J_MEA_T_PROBE_TYPE[0 .. 5]	
N51776 \$MNS_J_MEA_T_PROBE_ALLOW_AX_DIR[0 .. 5]	
N51778 \$MNS_J_MEA_T_PROBE_DIAM_LENGTH[0 .. 5]	
N51782 \$MNS_J_MEA_T_PROBE_T_EDGE_DIST[0 .. 5]	
N51787 \$MNS_J_MEA_T_PROBE_MEASURE_FEED	
N52605 \$MCS_MEA_TURN_CYC_SPECIAL_MODE	
	N52248 \$MCS_REV_2_BORDER_TOOL_LENGTH
	N52290 \$MCS_SIM_DISPLAY_CONFIG
	N52740 \$MCS_MEA_FUNCTION_MASK
	N52751 \$MCS_J_MEA_MAGN_GLAS_POS[0]
	N52751 \$MCS_J_MEA_MAGN_GLAS_POS[1]

A.3 Complete overview of the changed cycle machine and cycle setting data

Table A- 2 Complete overview of the changed cycle setting data

SW 02.06.01.03 HF3 CYCLE SW 02.06.56.00	CYCLE SW 04.04.05.00
	N54611 \$SNS_MEA_WP_FEED[0 .. 11]
	N54636 \$SNS_MEA_TP_FEED[0 .. 5]
	N54651 \$SNS_MEA_TPW_FEED[0 .. 5]
	N54652 \$SNS_MEA_INPUT_TOOL_PROBE_SUB[0 .. 5]
	N54740 \$SNS_MEA_FUNCTION_MASK
	N54760 \$SNS_MEA_FUNCTION_MASK_PIECE
	N54762 \$SNS_MEA_FUNCTION_MASK_TOOL
	N54764 \$SNS_MEA_FUNCTION_MASK_TURN
N54798 \$SNS_J_MEA_FUNCTION_MASK_PIECE	N54780 \$SNS_J_MEA_FUNCTION_MASK_PIECE
N54799 \$SNS_J_MEA_FUNCTION_MASK_TOOL	N54782 \$SNS_J_MEA_FUNCTION_MASK_TOOL
N54655 \$SNS_MEA_REPEAT_ACTIVE	
N54656 \$SNS_MEA_REPEAT_WITH_M0	
N54657 \$SNS_MEA_TOL_ALARM_SET_M0	
N54659 \$SNS_MEA_TOOL_MEASURE_RELATE	
N54660 \$SNS_MEA_PROBE_BALL_RAD_IN_TOA	
N55600 \$SCS_MEA_COLLISION_MONITORING	
N55602 \$SCS_MEA_COUPL_SPIND_COORD	
N55604 \$SCS_MEA_SPIND_MOVE_DIR	
N55606 \$SCS_MEA_NUM_OF_MEASURE	
N55608 \$SCS_MEA_RETRACTION_FEED	
N55610 \$SCS_MEA_FEED_TYP	
	N55628 \$SCS_MEA_TP_FEED_MEASURE
	N55630 \$SCS_MEA_FEED_MEASURE
N55630 \$SCS_MEA_FEED_RAPID_IN_PERCENT	N55632 \$SCS_MEA_FEED_RAPID_IN_PERCENT
N55631 \$SCS_MEA_FEED_PLANE_VALUE	N55634 \$SCS_MEA_FEED_PLANE_VALUE
N55632 \$SCS_MEA_FEED_FEEDAX_VALUE	N55636 \$SCS_MEA_FEED_FEEDAX_VALUE
N55633 \$SCS_MEA_FEED_FAST_MEASURE	N55638 \$SCS_MEA_FEED_FAST_MEASURE
	N55640 \$SCS_MEA_FEED_CIRCLE
	N55642 \$SCS_MEA_EDGE_SAVE_ANG
	N55740 \$SCS_MEA_FUNCTION_MASK
N55761 \$SCS_J_MEA_SET_NUM_OF_ATTEMPTS	
N55762 \$SCS_J_MEA_SET_RETRAC_MODE	
N55763 \$SCS_J_MEA_SET_FEED_MODE	
N55770 \$SCS_J_MEA_SET_COUPL_SP_COORD	
N55771 \$SCS_J_MEA_SET_CAL_MODE	
N55772 \$SCS_J_MEA_SET_PROBE_MONO	

A.4 Comparing GUD parameters (regarding measuring functions)

You can make specific basic settings per cycle machine, setting data (MD, SD).

The following prefixes are defined:

- §SNS_... Generally applicable setting data
- §SCS_... Channel-specific setting data
- §MNS_... Generally applicable machine data
- §MCS_... Channel-specific machine data

The GUD parameters listed in the following table represent the contents of the GUD blocks GUD5, GUD6 and GUD7_MC up to version V7.5 where equivalent MD/SD is available as from version V2.7 / V4.4.

The GUD are backwards compatible with existing measuring programs regarding their use.

The GUD5, GUD6 and GUD7_MC modules are replaced by the PGUD (SGUD in the parameter display).

GUD up to Version 7.5	MD/SD version V2.7 / V4.4
_WP[x,0]	SD54600 §SNS_MEA_WP_BALL_DIAM[0...11]
_WP[x,1]	SD54601 §SNS_MEA_WP_TRIG_MINUS_DIR_AX1[0...11]
_WP[x,2]	SD54602 §SNS_MEA_WP_TRIG_PLUS_DIR_AX1[0...11]
_WP[x,3]	SD54603 §SNS_MEA_WP_TRIG_MINUS_DIR_AX2[0...11]
_WP[x,4]	SD54604 §SNS_MEA_WP_TRIG_PLUS_DIR_AX2[0...11]
_WP[x,5]	SD54605 §SNS_MEA_WP_TRIG_MINUS_DIR_AX3[0...11]
_WP[x,6]	SD54606 §SNS_MEA_WP_TRIG_PLUS_DIR_AX3[0...11]
_WP[x,7]	SD54607 §SNS_MEA_WP_POS_DEV_AX1[0...11]
_WP[x,8]	SD54608 §SNS_MEA_WP_POS_DEV_AX2[0...11]
_WP[x,9]	SD54609 §SNS_MEA_WP_STATUS_RT[0...11]
_WP[x,10]	SD54610 §SNS_MEA_WP_STATUS_GEN[0...11]
_KB[x,0]	SD54621 §SNS_MEA_CAL_EDGE_PLUS_DIR_AX2[0...2]
_KB[x,1]	SD54622 §SNS_MEA_CAL_EDGE_MINUS_DIR_AX2[0...2]
_KB[x,2]	SD54615 §SNS_MEA_CAL_EDGE_BASE_AX1[0...2]
_KB[x,3]	SD54617 §SNS_MEA_CAL_EDGE_PLUS_DIR_AX1[0...2]
_KB[x,4]	SD54618 §SNS_MEA_CAL_EDGE_MINUS_DIR_AX1[0...2]
_KB[x,5]	SD54620 §SNS_MEA_CAL_EDGE_UPPER_AX2[0...2]
_KB[x,6]	SD54619 §SNS_MEA_CAL_EDGE_BASE_AX2[0...2]
_TP[x,0]	SD54625 §SNS_MEA_TP_TRIG_MINUS_DIR_AX1[0...5]
_TP[x,1]	SD54626 §SNS_MEA_TP_TRIG_PLUS_DIR_AX1[0...5]
_TP[x,2]	SD54627 §SNS_MEA_TP_TRIG_MINUS_DIR_AX2[0...5]
_TP[x,3]	SD54628 §SNS_MEA_TP_TRIG_PLUS_DIR_AX2[0...5]
_TP[x,4]	SD54629 §SNS_MEA_TP_TRIG_MINUS_DIR_AX3[0...5]
_TP[x,5]	SD54630 §SNS_MEA_TP_TRIG_PLUS_DIR_AX3[0...5]

A.4 Comparing GUD parameters (regarding measuring functions)

GUD up to Version 7.5	MD/SD version V2.7 / V4.4
_TP[x,6] und E_MESS_MT_DL[3]	SD54631 \$\$SNS_MEA_TP_EDGE_DISK_SIZE[0...5]
_TP[x,7] and E_MESS_MT_AX[3]	SD54632 \$\$SNS_MEA_TP_AX_DIR_AUTO_CAL[0...5]
_TP[x,8] and E_MESS_MT_TYP[3]	SD54633 \$\$SNS_MEA_TP_TYPE[0...5]
_TP[x,9] and E_MESS_MT_DZ[3]	SD54634 \$\$SNS_MEA_TP_CAL_MEASURE_DEPTH[0...5]
_TPW[x,1]	SD54641 \$\$SNS_MEA_TPW_TRIG_PLUS_DIR_AX1[0...5]
_TPW[x,2]	SD54642 \$\$SNS_MEA_TPW_TRIG_MINUS_DIR_AX2[0...5]
_TPW[x,3]	SD54643 \$\$SNS_MEA_TPW_TRIG_PLUS_DIR_AX2[0...5]
_TPW[x,4]	SD54644 \$\$SNS_MEA_TPW_TRIG_MINUS_DIR_AX3[0...5]
_TPW[x,5]	SD54645 \$\$SNS_MEA_TPW_TRIG_PLUS_DIR_AX3[0...5]
_TPW[x,6]	SD54646 \$\$SNS_MEA_TPW_EDGE_DISK_SIZE[0...5]
_TPW[x,7]	SD54647 \$\$SNS_MEA_TPW_AX_DIR_AUTO_CAL[0...5]
_TPW[x,8]	SD54648 \$\$SNS_MEA_TPW_TYPE[0...5]
_TWP[x,9]	SD54649 \$\$SNS_MEA_TPW_CAL_MEASURE_DEPTH[0...5]
_CM[0]	SD54670 \$\$SNS_MEA_CM_MAX_PERI_SPEED[0]
_CM[1]	SD54671 \$\$SNS_MEA_CM_MAX_REVOLUTIONS[0]
_CM[4]	SD54672 \$\$SNS_MEA_CM_MAX_FEEDRATE[0]
_CM[2]	SD54673 \$\$SNS_MEA_CM_MIN_FEEDRATE[0]
_CM[5]	SD54674 \$\$SNS_MEA_CM_SPIND_ROT_DIR[0]
_CM[6]	SD54675 \$\$SNS_MEA_CM_FEEDFACTOR_1[0]
_CM[7]	SD54676 \$\$SNS_MEA_CM_FEEDFACTOR_2[0]
_CM[3]	SD54677 \$\$SNS_MEA_CM_MEASURING_ACCURACY[0]
_CM[8]	MD51618 \$\$MNS_MEA_CM_ROT_AX_POS_TOL[0]
_CBIT[0]	SD54740 \$\$SNS_MEA_FUNCTION_MASK bit 0 (measure workpiece) SD54740 \$\$SNS_MEA_FUNCTION_MASK bit 16 (measure tool)
_CBIT[1]	SD54740 \$\$SNS_MEA_FUNCTION_MASK bit 1 (measure workpiece) SD54740 \$\$SNS_MEA_FUNCTION_MASK bit 17 (measure tool)
_CBIT[2]	SD54740 \$\$SNS_MEA_FUNCTION_MASK bit 2 (measure workpiece) SD54740 \$\$SNS_MEA_FUNCTION_MASK bit 18 (measure tool)
_CBIT[7]	MD51740 \$\$MNS_MEA_FUNCTION_MASK bit 2 (measure workpiece) MD51740 \$\$MNS_MEA_FUNCTION_MASK bit 16 (measure tool)
_CBIT[8]	MD51740 \$\$MNS_MEA_FUNCTION_MASK bit 3
_CBIT[14]	MD51740 \$\$MNS_MEA_FUNCTION_MASK bit 1
_CBIT[15]	SD54740 \$\$SNS_MEA_FUNCTION_MASK bit 3
_CBIT[16]	MD51740 \$\$MNS_MEA_FUNCTION_MASK bit 0
_CHBIT[0]	MD52740 \$\$MCS_MEA_FUNCTION_MASK bit 0
_CHBIT[1]	MD52740 \$\$MCS_MEA_FUNCTION_MASK bit 16

A.4 Comparing GUD parameters (regarding measuring functions)

GUD up to Version 7.5	MD/SD version V2.7 / V4.4
_CHBIT[2]	SD55740 \$SCS_MEA_FUNCTION_MASK bit 0 (measure workplace) SD55740 \$SCS_MEA_FUNCTION_MASK bit 16 (measure tool)
_CHBIT[10]	SD55613 \$SCS_MEA_RESULT_DISPLAY
_CHBIT[13]	SD55740 \$SCS_MEA_FUNCTION_MASK bit 1
_CHBIT[14]	SD55740 \$SCS_MEA_FUNCTION_MASK bit 2
_CHBIT[15]	SD55740 \$SCS_MEA_FUNCTION_MASK bit 3 (measure workplace) SD55740 \$SCS_MEA_FUNCTION_MASK bit 17 (measure tool)
_CHBIT[16]	SD55740 \$SCS_MEA_FUNCTION_MASK bit 5 (measure workplace) SD55740 \$SCS_MEA_FUNCTION_MASK bit 19 (measure tool)
_CHBIT[17]	SD55740 \$SCS_MEA_FUNCTION_MASK bit 4 (measure workplace) SD55740 \$SCS_MEA_FUNCTION_MASK bit 18 (measure tool)
_CHBIT[19]	MD52740 \$MCS_MEA_FUNCTION_MASK bit 1
_CHBIT[22]	SD54740 \$SNS_MEA_FUNCTION_MASK bit 19
_EVMVNUM[0]	SD55622 \$SCS_MEA_EMPIRIC_VALUE
_EVMVNUM[1]	SD55624 \$SCS_MEA_AVERAGE_VALUE
_EV[20]	SD55623 \$SCS_MEA_EMPIRIC_VALUE[0...19]
_MV[20]	SD55625 \$SCS_MEA_AVERAGE_VALUE[0...19]
_SPEED[0]	SD55632 \$SCS_MEA_FEED_RAPID_IN_PERCENT
_SPEED[1]	SD55634 \$SCS_MEA_FEED_PLANE_VALUE
_SPEED[2]	SD55636 \$SCS_MEA_FEED_FEEDAX_VALUE
_SPEED[3]	SD55638 \$SCS_MEA_FEED_FAST_MEASURE
_TP_CF	SD54690 \$SNS_MEA_T_PROBE_MANUFACTURER
_MT_COMP	SD54691 \$SNS_MEA_T_PROBE_OFFSET
_MT_EC_R[1.5]	SD54695 \$SNS_MEA_RESULT_OFFSET_TAB_RAD1[0...4]
_MT_EC_R[2.5]	SD54696 \$SNS_MEA_RESULT_OFFSET_TAB_RAD2[0...4]
_MT_EC_R[3.5]	SD54697 \$SNS_MEA_RESULT_OFFSET_TAB_RAD3[0...4]
_MT_EC_R[4.5]	SD54698 \$SNS_MEA_RESULT_OFFSET_TAB_RAD4[0...4]
_MT_EC_R[5.5]	SD54699 \$SNS_MEA_RESULT_OFFSET_TAB_RAD5[0...4]
_MT_EC_R[6.5]	SD54700 \$SNS_MEA_RESULT_OFFSET_TAB_RAD6[0...4]
_MT_EC_L[1.5]	SD54705 \$SNS_MEA_RESULT_OFFSET_TAB_LEN1[0...4]
_MT_EC_L[2.5]	SD54706 \$SNS_MEA_RESULT_OFFSET_TAB_LEN2[0...4]
_MT_EC_L[3.5]	SD54707 \$SNS_MEA_RESULT_OFFSET_TAB_LEN3[0...4]
_MT_EC_L[4.5]	SD54708 \$SNS_MEA_RESULT_OFFSET_TAB_LEN4[0...4]
_MT_EC_L[5.5]	SD54709 \$SNS_MEA_RESULT_OFFSET_TAB_LEN5[0...4]
_MT_EC_L[6.5]	SD54710 \$SNS_MEA_RESULT_OFFSET_TAB_LEN6[0...4]
E_MESS_D	MD51750 \$MNS_J_MEA_M_DIST
E_MESS_D_M	MD51751 \$MNS_J_MEA_M_DIST_MANUELL

A.5 Changes to names of cycle programs and GUD modules

GUD up to Version 7.5	MD/SD version V2.7 / V4.4
E_MESS_D_L	MD51752 \$MNS_J_MEA_M_DIST_TOOL_LENGTH
E_MESS_D_R	MD51753 \$MNS_J_MEA_M_DIST_TOOL_RADIUS
E_MESS_FM	SD55630 \$SCS_MEA_FEED_MEASURE
E_MESS_F	MD51757 \$MNS_J_MEA_COLL_MONIT_FEED
E_MESS_FZ	MD51758 \$MNS_J_MEA_COLL_MONIT_POS_FEED
E_MESS_CAL_D[2]	MD51770 \$MNS_J_MEA_CAL_RING_DIAM[0...11]
E_MESS_CAL_L[0]	MD51772 \$MNS_J_MEA_CAL_HEIGHT_FEEDAX[0...11]
E_MESS_MT_DR[3]	MD51780 \$MNS_J_MEA_T_PROBE_DIAM_RAD[0...5]
E_MESS_MT_DIR[3]	MD51784 \$MNS_J_MEA_T_PROBE_APPR_AX_DIR[0...5]
E_MESS_SETT[0]	SD55740 \$SCS_MEA_FUNCTION_MASK bit 14
E_MESS_SETT[1]	SD55740 \$SCS_MEA_FUNCTION_MASK bit 15

A.5 Changes to names of cycle programs and GUD modules

The following measuring programs have been renamed or deleted from measuring cycle version 2.6:

Cycle Name of GUD up to Version 7.5	Cycle Name as of Version 2.6
CYC_JMC	Cycle131
CYC_JMA	Cycle132
Cycle198	CUST_MEACYC
Cycle199	CUST_MEACYC
Cycle100	Program is no longer available.
Cycle101	Program is no longer available.
Cycle105	Program is no longer available.
Cycle106	Program is no longer available.
Cycle107	Program is no longer available.
Cycle108	Program is no longer available.
Cycle113	Program is no longer available.
Cycle118	Program is no longer available.
Cycle972	Program is no longer available.
E_SP_NPV	Program is no longer available.
CYC_JM	Program is no longer available.
GUD5	Module no longer available.
GUD6	Module no longer available.
GUD7	Module no longer available.
GUD7_MC	Module no longer available.

Appendix

B.1 Abbreviations

Abbreviation	Meaning
CNC	Computerized Numerical Control Computerized numerical control
DIN	Deutsche Industrie Norm (German Industry Standard)
I/O	Input/Output
GUD	Global User Data Global user data
JOG	JOGging: Setup mode
MD	Machine data
MCS	Machine coordinate system
NC	Numerical Control: Numerical Control
NCK	Numerical Control Kernel: NC kernel with block preparation, traversing range, etc.
NCU	Numerical Control Unit: NCK hardware unit
WO	Zero point offset
PLC	Programmable Logic Control Controller
SL	Cutting edge position
Software	Software
WCS	Workpiece coordinate system

B.2 Documentation overview

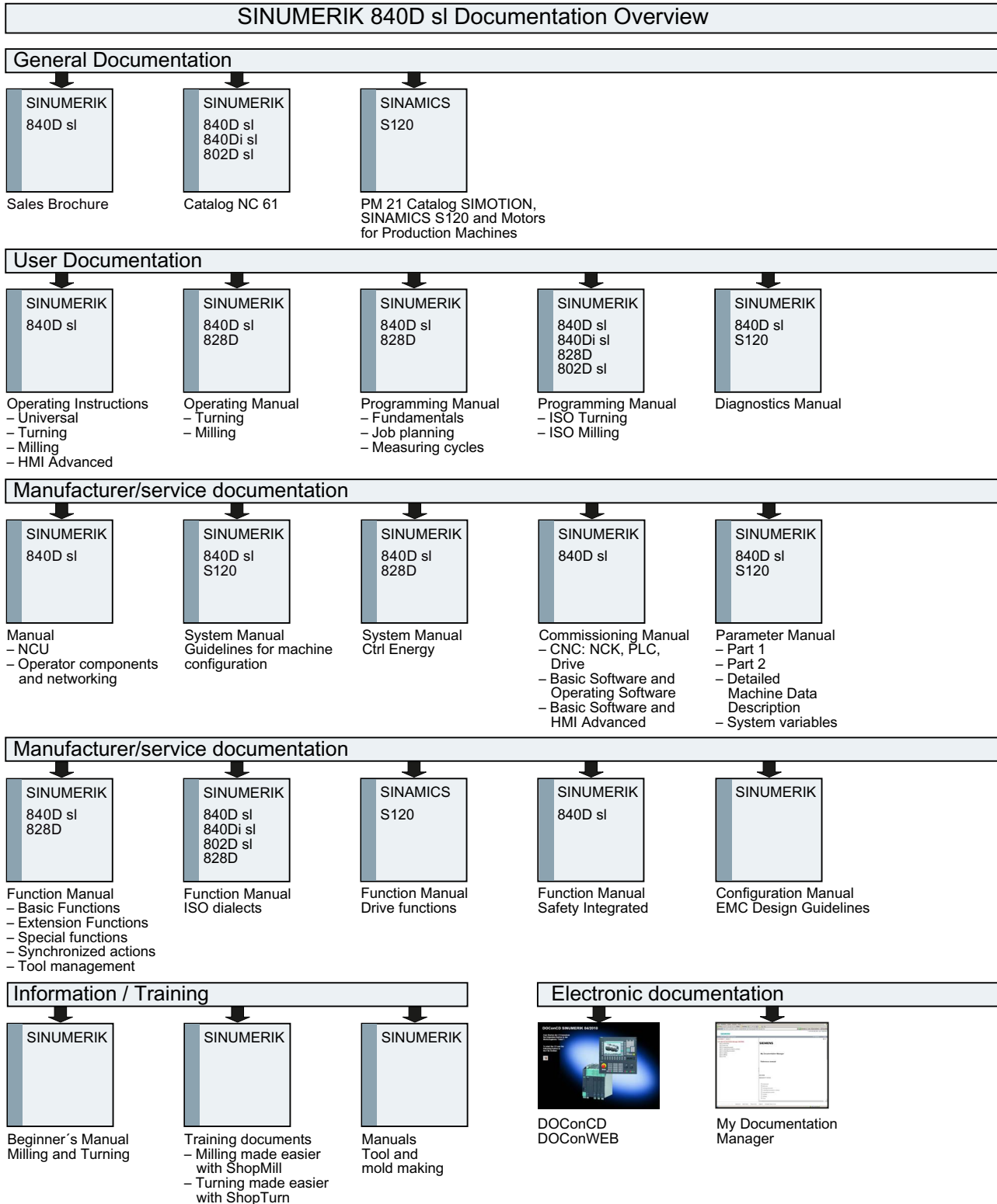

Glossary

Actual/set difference

Difference between measured and expected value.

Asynchronous subroutine

Part program that can be started asynchronously to (independently of) the current program status using an interrupt signal (e.g., "Rapid NC input" signal).

Calibration

When calibrating, the trigger points of the probe are identified and saved in the cycle setting data from SD 54600.

Calibration tool

Is a special tool (usually a cylindrical stylus), whose dimensions are known and that is used for precisely determining the distances between the machine zero and the probe trigger point (of the workpiece probe).

Collision monitoring

In the context of measuring cycles, this is a function that monitors all intermediate positions generated within the measuring cycle for the switching signal of the probe. When the probe switches, motion is stopped immediately and an alarm message is output.

Delete distance-to-go

If a measuring point is to be approached, a traverse command is transmitted to the position control loop and the probe is moved towards the measuring point. A point behind the expected measuring point is defined as setpoint position. As soon as the probe makes contact, the actual axis value at the time the switching position is reached is measured and the drive is stopped. The remaining "distance-to-go" is deleted.

Differential measurement

Differential measurement means that the 1st measuring point is measured twice, once with a 180 degree spindle reversal (rotation of the probe), i.e. opposite the cycle start position and once with the spindle position that was available at the start of the cycle. This procedure allows uncalibrated probes to be used without imposing less stringent precision requirements!

Dimension difference check

Is a tolerance parameter, and when a limit (s_{DIF}) is reached the tool is probably worn and must be replaced. The dimension difference check has no effect on generation of the compensation value.

Empirical value

The empirical values are used to suppress constant dimensional deviations that are not subject to a trend.

Flying measurement

This method processes the probe signal directly in the NC.

Lower tolerance limit

When measuring a dimensional deviation as the lower tolerance limit (s_{TLL}) ranging between "2/3 tolerance of workpiece" and "Dimensional difference control", this is regarded 100 % as tool offset. The previous average value is deleted.

Mean value

The mean value calculation takes account of the trend of the dimensional deviations of a machining series. The → weighting factor k – used as basis for forming the mean value – is selectable.

Mean value calculation alone is not enough to ensure constant machining quality. The measured dimensional deviation can be corrected for constant deviations without a trend by using an → empirical value.

Measure tool

To measure the tool, the new tool is moved up to the probe which is either permanently fixed or swiveled into the working range. The automatically derived tool geometry is entered in the relevant tool offset data record.

Measure workpiece

For workpiece measurement, a measuring probe is moved up to the clamped workpiece in the same way as a tool. The flexibility of measuring cycles makes it possible to perform nearly all measurements required on a milling or turning machine.

Measurement path

Measurement path DFA defines the distance between the starting position and the expected switching position (setpoint) of the probe.

Measurement result display

Measurement result displays can be shown automatically during measuring cycle runtime. The function is dependent on the settings in the channel-specific SD 55613 \$SCS_MEA_RESULT_DISPLAY.

Measuring accuracy

The measurement accuracy that can be obtained is dependent on the following factors:

- Repeat accuracy of the machine
- Repeat accuracy of the probe
- Resolution of the measuring system

The repeat accuracy of the controls for "on-the-fly measurement" is $\pm 1 \mu\text{m}$.

Measuring at an angle

A measurement version used to measure a hole, spigot (shaft), groove, or a web at any angle. The measurement path is traveled at a certain set angle defined in the WCS.

Measuring blanks

The blank measurement determines the position, deviation, and work offset of the workpiece in the result of a → workpiece measurement.

Measuring in JOG

It contains the following functions:

- Semi-automatic calculation of tool geometry and storage in the tool offset memory
- Semi-automatic calculation and setting of reference points and storage in work offset memory

The function is operated with softkeys and input displays.

Measuring version

The measuring version of each measuring cycle is defined in parameter S_MVAR . The parameter can have certain integer values for each measuring cycle, which are checked for validity within the cycle.

Mono probe

A mono(directional) probe is a probe that can only deflect in one direction. It can only be used for workpiece measurement on milling machines and machining centers with slight limitations.

Multi probe

A multi(directional) probe is one that can deflect in three dimensions.

Multiple measurement at the same location

Parameter `S_NMSP` can be used to determine the number of measurements at the same point. The actual/set difference is determined arithmetically.

Offset angle position

When using a → mono probe, for machine-specific reasons it may be necessary to correct the position of the probe using the tool data in mono probe type 712.

Offset axis

With some measuring versions, for example, measuring an angle in CYCLE998, positioning in another axis that must be defined, (also called offset axis) can be performed between measurements in the measuring axis. This must be defined in parameter `S_MA` with offset axis/measuring axis.

Paraxial measurement

A measuring version used for paraxial measurement of a workpiece, such as a hole, spigot (shaft), rectangle, etc. The measuring path is traversed paraxially in the workpiece coordinate system.

Positional deviation

The positional deviation (skew) describes the difference between the spindle center and the probe tip center ascertained by calibration. It is compensated for by the measuring cycles.

Probe ball diameter

The active diameter of the probe ball. It is ascertained during calibration and stored in the measuring cycle data.

Probe type

To measure tool and workpiece dimensions, an electronic touch-trigger probe is required that provides a signal change (edge) when deflected.

Probes are distinguished according to the number of measuring directions.

- Multi-directional (3D, multi probe)
- Mono directional (mono probe)

Reference groove

A groove located in the working area (permanent feature of the machine) whose precise position is known and that can be used to calibrate workpiece probes.

Safe area

The safe area s_TSA does not affect the offset value; it is used for diagnostics. If this limit is reached, there is a defect in the probe or the set position is incorrect.

Setpoint

In the "on-the-fly measurement" procedure, a position is specified as the setpoint value for the cycle at which the signal of the touch-trigger probe is expected.

Tool name

Name of the tool in the tool list.

Trigger point

When calibrating, the trigger points of the probe are determined and saved in the channel-specific setting data from SD 54600 and higher for the corresponding axis direction.

Upper tolerance limit

When measuring a dimensional deviation as the upper tolerance limit (s_TU) ranging between "2/3 tolerance of workpiece" and "Dimensional difference control", this is regarded 100% as tool offset. The previous average value is deleted.

Weighting factor for averaging

The weighting factor k can be applied to allow different weighting to be given to an individual measurement.

A new measurement result thus has only a limited effect on the new tool offset as a function of k .

Work offset (WO)

In the result of a measurement, the actual-setpoint value difference is stored in the data set of any settable work offset.

Work offset range

This tolerance range (lower limit s_TZL) corresponds to the absolute value of maximum random dimensional deviations. If the absolute value of the actual/set difference is less than the work offset range, the offset is not applied.

Index

C

Calculation of center point and radius of a circle, 44
Calculation of the deceleration distance, 32
Calibration tool, 29
compensation value calculation, 35
CYCLE116, 44

D

Dimension difference check, 39
Dimensional deviations, 35

E

Effect of empirical value, mean value, and tolerance parameters, 43

F

Flying measurement, 30

L

Lower tolerance limit, 39

M

Mean value, 35
Mean value calculation, 35
Measure tool (milling)
 Calibrate probe (CYCLE971), 208
 Measuring - tool (CYCLE971), 214
 Single cutting edge measurement (CYCLE971), 218
Measure tool (turning)
 Calibrate probe (CYCLE982), 184
 Measuring - drill (CYCLE982), 199
 Measuring - milling tool (CYCLE982), 192
 Measuring - turning tool (CYCLE982), 188
Measure workpiece (milling)
 Calibrate on ball (CYCLE976), 94
 Calibrate radius at edge (CYCLE976), 91
 Calibrate radius in ring (CYCLE976), 87

Length alignment (CYCLE976), 83
Measurement - angular deviation spindle (CYCLE995), 161
Measuring - 1 circular spigot (CYCLE977), 140
Measuring - 1 hole (CYCLE977), 128
Measuring - 3 balls (CYCLE997), 156
Measuring - align edge (CYCLE998), 101
Measuring - align plane (CYCLE998), 148
Measuring - any corner (CYCLE961), 120
Measuring - ball (CYCLE997), 152
Measuring - groove (CYCLE977), 107
Measuring - inner circle segment (CYCLE979), 132
Measuring - kinematics (CYCLE996), 165
Measuring - outer circle segment (CYCLE979), 144
Measuring - rectangular pocket (CYCLE977), 124
Measuring - rectangular spigot (CYCLE977), 136
Measuring - rib (CYCLE977), 112
Measuring - right-angled corner (CYCLE961), 116
Measuring - set edge (CYCLE978), 97

Measure workpiece (turning)

Calibrate - probe in groove (CYCLE973), 63
Calibration - length (CYCLE973), 57
Calibration - radius on surface (CYCLE973), 60
Extended measurement, 81
Measurement - front edge (CYCLE974), 67
Measurement - inside diameter (CYCLE974, CYCLE994), 71
Measurement - outside diameter (CYCLE974, CYCLE994), 76

Measurement result display, 47

Measuring cycle support in the program editor (from SW 6.2), 46

Measuring accuracy, 33

Measuring cycle parameters

CYCLE961, 243
CYCLE971, 260
CYCLE973, 223
CYCLE974, 226
CYCLE976, 232
CYCLE977, 240
CYCLE978, 234
CYCLE979, 246
CYCLE982, 257
CYCLE994, 229
CYCLE995, 252
CYCLE996, 254
CYCLE997, 249
CYCLE998, 237

Measuring strategy, 35
Measuring velocity, 32
Menu tree
 Milling technology, 53
 Turning technology, 51

P

Parameters for checking the measurement result and offset, 38
Probe, 18
 L probe, 20
 Mono probe, 20
 Multi probe, 20
 Star probe, 21
 Tool probe, 18
 Workpiece probe, 19
Probes that can be used, 18

R

Reference points at machine and workpiece, 13
Result parameters, 55

S

Safe area, 39
Starting position/Setpoint position, 31

T

Tool measurement, 10

U

Upper tolerance limit, 39
User Program
 before undertaking measurement, 46

W

Work offset (WO), 13
Work offset range, 40
Workpiece measurement, 9
Workpiece probe, 22