

SIEMENS

SIMATIC

S7-1500/ET 200MP
Load power supply module
PM 70 W 120/230VAC
(6EP1332-4BA00)

Manual

Preface

Documentation guide

1

Product overview

2

Connection

3

Parameter

4

Alarms, diagnostic, error and
status messages

5

Technical specifications

6

Dimension drawing

A



Parameter data set

B

Legal information

Warning notice system

This manual contains notices you have to observe in order to ensure your personal safety, as well as to prevent damage to property. The notices referring to your personal safety are highlighted in the manual by a safety alert symbol, notices referring only to property damage have no safety alert symbol. These notices shown below are graded according to the degree of danger.

 DANGER
indicates that death or severe personal injury will result if proper precautions are not taken.
 WARNING
indicates that death or severe personal injury may result if proper precautions are not taken.
 CAUTION
indicates that minor personal injury can result if proper precautions are not taken.
NOTICE
indicates that property damage can result if proper precautions are not taken.

If more than one degree of danger is present, the warning notice representing the highest degree of danger will be used. A notice warning of injury to persons with a safety alert symbol may also include a warning relating to property damage.

Qualified Personnel

The product/system described in this documentation may be operated only by **personnel qualified** for the specific task in accordance with the relevant documentation, in particular its warning notices and safety instructions. Qualified personnel are those who, based on their training and experience, are capable of identifying risks and avoiding potential hazards when working with these products/systems.

Proper use of Siemens products

Note the following:

 WARNING
Siemens products may only be used for the applications described in the catalog and in the relevant technical documentation. If products and components from other manufacturers are used, these must be recommended or approved by Siemens. Proper transport, storage, installation, assembly, commissioning, operation and maintenance are required to ensure that the products operate safely and without any problems. The permissible ambient conditions must be complied with. The information in the relevant documentation must be observed.

Trademarks

All names identified by ® are registered trademarks of Siemens AG. The remaining trademarks in this publication may be trademarks whose use by third parties for their own purposes could violate the rights of the owner.

Disclaimer of Liability

We have reviewed the contents of this publication to ensure consistency with the hardware and software described. Since variance cannot be precluded entirely, we cannot guarantee full consistency. However, the information in this publication is reviewed regularly and any necessary corrections are included in subsequent editions.

Preface

Purpose of this documentation

This manual supplements the system manuals:

- S7-1500 automation system
(<http://support.automation.siemens.com/WW/view/en/59191792>)
- ET 200MP distributed I/O system
(<http://support.automation.siemens.com/WW/view/en/59193214>)

General system functions are described there.

The information in this manual along with the System/Function manuals enables you to commission the systems.

Conventions

In the following, if "CPU" is mentioned, then this refers to the central modules of the S7-1500 automation system, as well as the interface modules of the ET 200MP distributed I/O.

Also observe the notes marked as follows:

Note

A note refers to important information about the product described in the documentation, for handling the product or to the part of the documentation to which special attention should be given.

Note on IT security

Siemens offers IT security mechanisms for its automation and drive product portfolio in order to support the safe operation of the plant/machine. We recommend that you inform yourself regularly on the IT security developments regarding your products. You can find information on this on the Internet (<http://support.automation.siemens.com>).

You can register for a product-specific newsletter here.

For the safe operation of a plant/machine, however, it is also necessary to integrate the automation components into an overall IT security concept for the entire plant/machine, which corresponds to the state-of-the-art IT technology. You can find information on this on the Internet (<http://www.siemens.com/industrialsecurity>).

Products used from other manufacturers should also be taken into account here.

Table of contents

	Preface	3
1	Documentation guide	7
2	Product overview	9
	2.1 Properties	9
	2.2 Operator controls and display elements	11
3	Connection	13
	3.1 Connecting up the power supply module	13
4	Parameter	15
5	Alarms, diagnostic, error and status messages	17
	5.1 Status and error displays	17
	5.2 Diagnostic messages	19
	5.3 Alarms	19
6	Technical specifications	21
A	Dimension drawing	23
B	Parameter data set	25

Documentation guide

Introduction

The documentation of the S7-1500 and ET 200MP system families has a modular structure, and includes topics associated with your automation system.

The complete documentation comprises various modules, which are subdivided into System Manuals, Function Manuals and Equipment Manuals.

An overview of the documents, which supplement this Manual, is provided in the following table.

Overview of the documentation for the power supply module PM 70 W 120/230 VAC

The following table lists additional documentation, which you require when using the load power supply module PM 70 W 120/230 VAC .

Table 1- 1 Documentation for the PM 70 W 120/230 VAC load power supply module

Subject	Documentation	Most important content
Description of the system	System Manual S7-1500 automation system (http://support.automation.siemens.com/WW/view/en/59191792) System Manual ET 200MP distributed I/O system (http://support.automation.siemens.com/WW/view/en/59193214)	<ul style="list-style-type: none"> • Planning its use • Installation • Connection • Commissioning • Standards and approvals • Electromagnetic compatibility • Mechanical and climatic environmental conditions
Configuring control systems so that they are interference-proof	Function Manual Configuring control systems so that they are interference-proof (http://support.automation.siemens.com/WW/view/en/59193566)	<ul style="list-style-type: none"> • Basic principles • Electromagnetic compatibility • Lightning protection
System diagnostics	Function Manual System diagnostics (http://support.automation.siemens.com/WW/view/en/59192926)	<ul style="list-style-type: none"> • Overview • Diagnostics evaluation, hardware/software

SIMATIC Manuals

In the Internet (<http://www.siemens.com/automation/service&support>) you will find all of the current manuals for SIMATIC products, that you can download at no charge.

Product overview

2.1 Properties

Order number

6EP1332-4BA00

View of the module

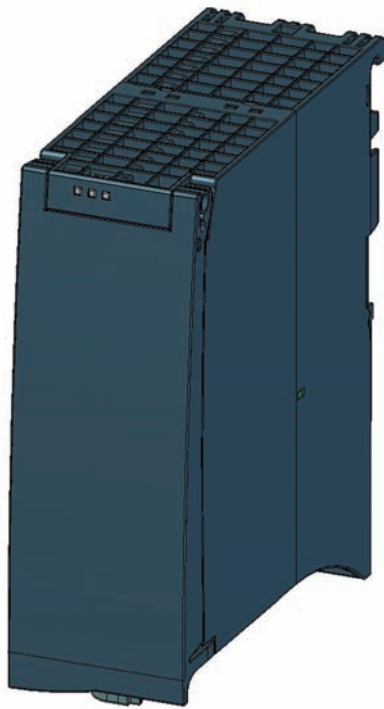

Figure 2-1 View of the PM 70 W 120/230 VAC load power supply module

Properties

The load power supply module PM 70 W 120/230 VAC feeds input and output circuits (load circuits) as well as sensors and actuators

The load power supply module has the following properties:

- Technical properties
 - Rated input voltage 120/230 V AC, 50/60 Hz
 - Automatic voltage range switchover
 - 24 V DC rated output voltage
 - 3 A rated output current
 - 70 W output power
 - Power failure buffering

Accessories

The following components can be supplied with the power module:

- Line connector
- Pluggable 24 V DC output terminal

2.2 Operator controls and display elements

The following diagram shows the operating and connection elements of the PM 70 W 120/230 VAC load power supply module behind the front cover, the line connector and the pluggable 24 V DC output terminal

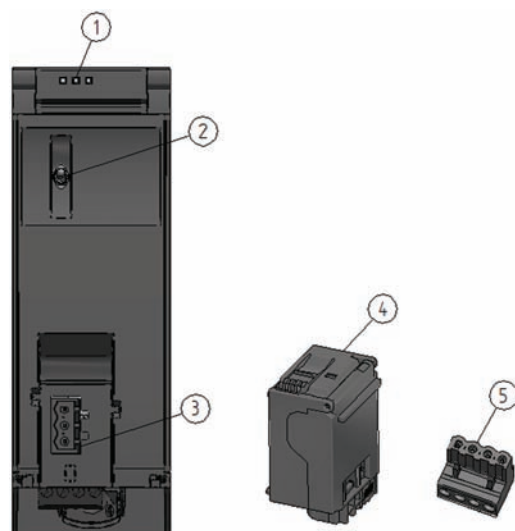

- ① LED displays showing the actual operating state and diagnostics state of the PM
- ② On / off switch
- ③ Power supply connection via the line connector
- ④ Line connector, inserted when delivered
- ⑤ Pluggable 24 V DC output terminal, inserted when delivered

Figure 2-2 View of the PM 70 W 120/230 VAC power supply module (without front cover), the line connector and the pluggable 24 V DC output terminal

Connection

3.1 Connecting up the power supply module

Line connection

 WARNING
Installation instructions
Death or severe injury can occur.
When connecting up the power supply module, carefully observe the general installation instructions that are valid in your particular country.
Protect the line connection cables corresponding to the cable cross-section.

The following applies to the line connection of the load power supply module with the line connector:

- The line connector allows the supply voltage to be connected to the load power supply with touch protection.
- The line connector facilitates permanent wiring to be established.
- The line connector has a strain relief mechanism.
- When supplied, every line connector is assigned to a power supply module type using a coding element. A connector, coded for 230 V AC, cannot be inserted in a 24 V DC power supply module.

24 V DC output

The following applies to the 24 V DC output of the load power supply module with pluggable 24 V DC output terminal:

- The 24 V DC output terminal allows loads to be connected with a 24 V DC input.
- The 24 V DC output terminal facilitates permanent wiring to be established.
- The 24 V DC output terminal guarantees protection against reverse polarity.

Cables

You must use flexible cables to connect the load power supply module. The wire cross-section can be 0.5 mm² up to 2.5 mm² (AWG: 24 to 12). A miniature circuit breaker or motor circuit breaker must be provided at the input side.

3.1 Connecting up the power supply module

Clearance to adjacent modules

For a horizontal system configuration (cable outlet towards the bottom), no installation clearances are required to the right-hand adjacent module; on the other hand, if there is a module to the left, then a minimum clearance of 10 mm must be provided.

For vertical system configurations (cable outlet to the right), a minimum clearance of 25 mm must be maintained to the upper adjacent module. If there is a lower adjacent module, then a minimum clearance of 20 mm must be maintained

Reference

Information on installing the load power supply module and wiring the line connector and the pluggable 24 V DC output terminal is provided in the System Manual S7-1500 automation system (<http://support.automation.siemens.com/WW/view/de/59191792>) and in the operating instructions for the load power supply module.

Parameter

PM 70 W 120/230 VAC parameters

The PM 70 W 120/230 VAC power supply module cannot be parameterized via STEP 7.

Alarms, diagnostic, error and status messages

5.1 Status and error displays

Introduction

The diagnostics provided by the LEDs provides the first resource to locate faults.

LED displays

The LED displays (status and error displays) of the PM 70 W 120/230 VAC load power supply module can be seen in the following diagram.

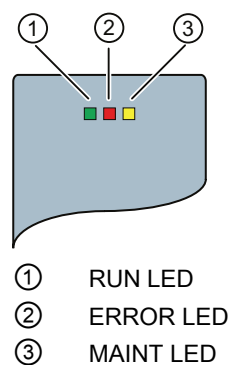

Figure 5-1 LED displays of the PM 70 W 120/230 VAC load power supply module

5.1 Status and error displays

Meaning of the LED displays

The significance of the status and error displays of the PM 70 W 120/230 VAC power supply module are explained in the following table.

Table 5- 1 RUN/ERROR/MAINT status and error displays

LED			Meaning	Remedy
RUN	ERROR	MAINT		
□ off	□ off	□ off	<p>POWER OFF PM deactivated</p> <ul style="list-style-type: none"> No power at the PM Standby switch in the "lower" position Device inactive No 24 V DC output voltage 	<p>Check the line supply Supply the PM with power Switch on the PM</p>
■ on	□ off	□ off	<p>POWER ON The PM supplies a 24 V DC output voltage</p> <ul style="list-style-type: none"> Line supply voltage is available at the PM Standby switch in the "upper" position Device active and in the regular operating mode 24 V DC output voltage is available 	-
□ off	■ on	□ off	<p>ERROR PM is operating in the overload mode</p> <ul style="list-style-type: none"> Line supply voltage is available at the PM Standby switch in the "upper" position Device is active, however, in the "Overload" operating mode The connected load draws more current than the PM can supply 24 V DC output voltage drops 	<p>Reduce the load current drawn by the connected load Install a load power supply with a higher rating</p>
□ off	□ off	■ on	<p>MAINTENANCE PM is in the standby mode</p> <ul style="list-style-type: none"> Line supply voltage is available at the PM Standby switch in the "lower" position Device is active, however, in the standby mode No 24 V DC output voltage 	<p>Switch on the PM by bringing the standby switch into the "upper" position</p>

5.2 Diagnostic messages

The PM 70 W 120/230 VAC load power supply module does not initiate diagnostic messages in the CPU or STEP 7. You can identify the device status directly at the PM based on the "LED statuses", as explained in Chapter Status and error displays (Page 17).

5.3 Alarms

The PM 70 W 120/230 VAC load power supply module does not initiate any alarms in the CPU or STEP 7. You can identify the device status directly at the PM based on the "LED statuses", as explained in Chapter Status and error displays (Page 17).

Technical specifications

Technical data of the PM 70 W 120/230 VAC load power supply module

	6EP1332-4BA00
Product type designation	PM 70 W 120/230 VAC
General Information	
Hardware product version	1
Firmware version	Not applicable
Engineering mit	
can be configured in the STEP 7 TIA-Portal / integrated from version	Not applicable
can be configured in STEP 7 / integrated from version	Not applicable
PROFIBUS from GSD version / GSD revision	Not applicable
Power supply	
• Rated value (AC)	120 V or 230 V (automatic switchover)
• Permissible range, lower limit (AC)	85 V or 170 V
• Permissible range, upper limit (AC)	132 V or 264 V
Input current	
• Rated value at 120 VAC	1.40 A
• Rated value at 230 VAC	0.80 A
Mains frequency	
• Rated value 50 Hz	Yes
• Rated value 60 Hz	Yes
• Permissible range, lower limit	45 Hz
• Permissible range, upper limit e	65 Hz
Line and power failure bypass	
• Line/power failure bypass time	20 ms
Output current	
• Rated value	3 A
• Short-circuit protection	Yes
Power	
• 24 V DC output power	194 W

	6EP1332-4BA00
Power loss <ul style="list-style-type: none"> Power loss, typical. 	10.6 W
Alarms / diagnostics / status information <ul style="list-style-type: none"> Status display 	Yes (using the device LEDs)
Electrical isolation <ul style="list-style-type: none"> Primary/secondary 	Yes
Degree of protection and protection class <ul style="list-style-type: none"> Degree of protection to EN 60529 Protection class 	IP20 I with protective conductor
Dimensions <ul style="list-style-type: none"> Width Height Depth 	50 mm 147 mm 129 mm
Weights <ul style="list-style-type: none"> Weight, approx. 	452 g

Dimension drawing

A

Dimension drawing of the PM 70 W 120/230 VAC load power supply module

The dimension drawing of the load power supply module, mounted on a rail with shield bar, is provided in this attachment. These dimensions must be taken into account when mounting in cabinets, switchgear rooms etc.

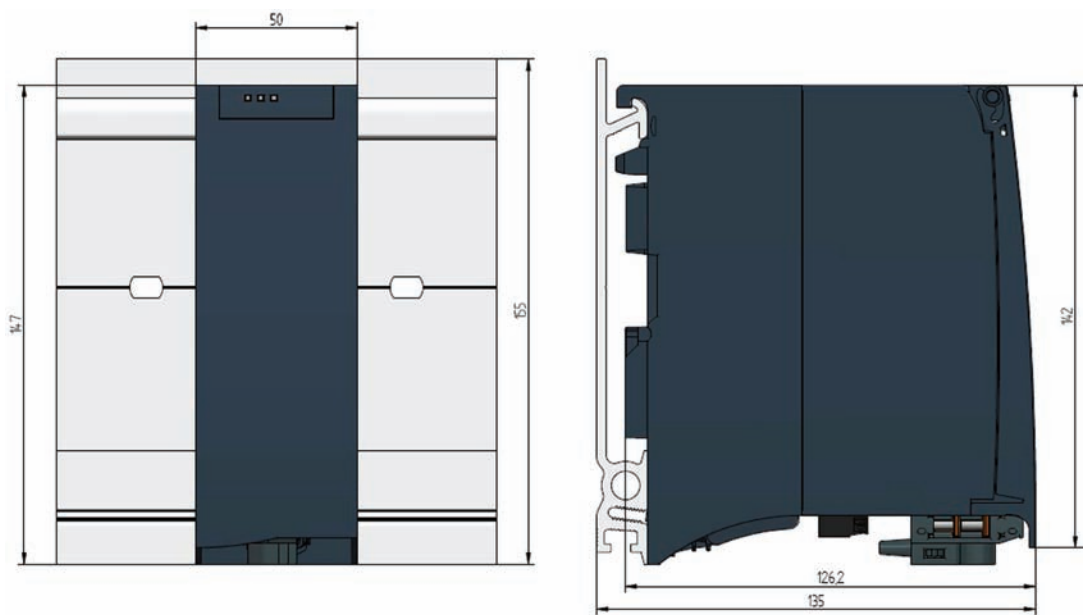

Figure A-1 Dimension drawing of the PM 70 W 120/230 VAC load power supply module

This drawing shows the module dimensions with the front cover open.

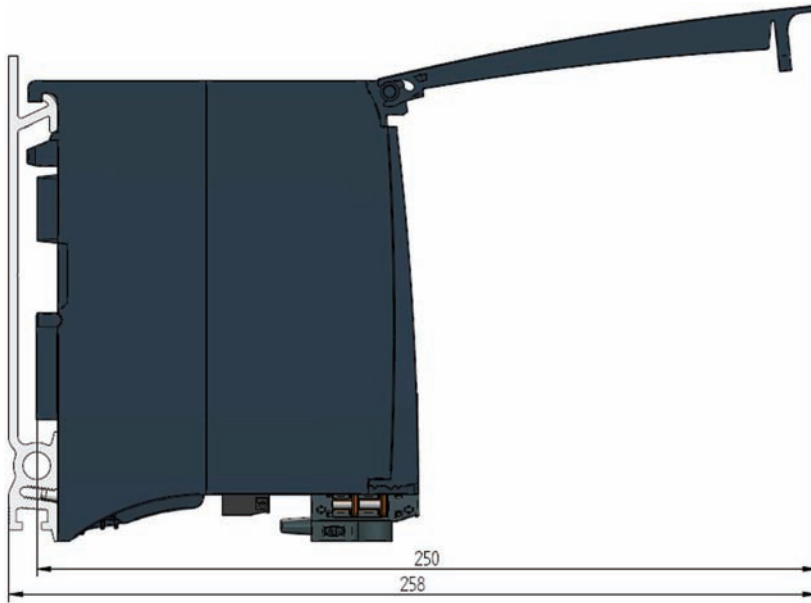

Figure A-2 Dimension drawing of the PM 70 W 120/230VAC load power supply module, side view with the front cover open

Parameter data set

The PM 70 W 120/230 VAC load power supply module does not provide any way of assigning parameters.

