

SIMATIC

ET 200SP



Product information on the
documentation of the ET 200SP
distributed I/O system

Product Information

Legal information

Warning notice system

This manual contains notices you have to observe in order to ensure your personal safety, as well as to prevent damage to property. The notices referring to your personal safety are highlighted in the manual by a safety alert symbol, notices referring only to property damage have no safety alert symbol. These notices shown below are graded according to the degree of danger.

 DANGER
indicates that death or severe personal injury will result if proper precautions are not taken.
 WARNING
indicates that death or severe personal injury may result if proper precautions are not taken.
 CAUTION
indicates that minor personal injury can result if proper precautions are not taken.
NOTICE
indicates that property damage can result if proper precautions are not taken.

If more than one degree of danger is present, the warning notice representing the highest degree of danger will be used. A notice warning of injury to persons with a safety alert symbol may also include a warning relating to property damage.

Qualified Personnel

The product/system described in this documentation may be operated only by **personnel qualified** for the specific task in accordance with the relevant documentation, in particular its warning notices and safety instructions. Qualified personnel are those who, based on their training and experience, are capable of identifying risks and avoiding potential hazards when working with these products/systems.

Proper use of Siemens products

Note the following:

 WARNING
Siemens products may only be used for the applications described in the catalog and in the relevant technical documentation. If products and components from other manufacturers are used, these must be recommended or approved by Siemens. Proper transport, storage, installation, assembly, commissioning, operation and maintenance are required to ensure that the products operate safely and without any problems. The permissible ambient conditions must be complied with. The information in the relevant documentation must be observed.

Trademarks

All names identified by ® are registered trademarks of Siemens Aktiengesellschaft. The remaining trademarks in this publication may be trademarks whose use by third parties for their own purposes could violate the rights of the owner.

Disclaimer of Liability

We have reviewed the contents of this publication to ensure consistency with the hardware and software described. Since variance cannot be precluded entirely, we cannot guarantee full consistency. However, the information in this publication is reviewed regularly and any necessary corrections are included in subsequent editions.

Preface

Validity

This product information supplements the documentation for the ET 200SP and takes precedence over our system manuals, function manuals and product manuals.

You can find additional information on the fail-safe ET 200SP CPUs in the Product Information for F-CPU's on the Internet (<https://support.industry.siemens.com/cs/ww/en/view/109478599>).

Cybersecurity information

Siemens provides products and solutions with industrial cybersecurity functions that support the secure operation of plants, systems, machines, and networks.

In order to protect plants, systems, machines, and networks against cyber threats, it is necessary to implement – and continuously maintain – a holistic, state-of-the-art industrial cybersecurity concept. Siemens' products and solutions constitute one element of such a concept.

Customers are responsible for preventing unauthorized access to their plants, systems, machines and networks. Such systems, machines and components should only be connected to an enterprise network or the internet if and to the extent such a connection is necessary and only when appropriate security measures (e.g. firewalls and/or network segmentation) are in place.

For more information on protective industrial cybersecurity measures for implementation, please visit (<https://www.siemens.com/global/en/products/automation/topic-areas/industrial-cybersecurity.html>).

Siemens' products and solutions undergo continuous development to make them more secure. Siemens strongly recommends that product updates are applied as soon as they are available and that the latest product versions are used. Use of product versions that are no longer supported, and failure to apply the latest updates may increase customers' exposure to cyber threats.

To stay informed about product updates at all times, subscribe to the Siemens Industrial Cybersecurity RSS Feed under

(<https://new.siemens.com/global/en/products/services/cert.html>).

Table of contents

1	Module overview of ET 200SP	5
1.1	Module firmware corrected for R1 redundancy	5
1.2	Possible combinations of BaseUnits and I/O modules	7
1.3	CPUs	15
1.4	Interface modules	18
1.5	BusAdapter	20
1.6	BaseUnits	20
1.7	I/O modules	22
1.8	Encoder modules for Module-to-Module Communication (MtM)	26
1.9	Motor starters	26
1.10	Accessories	27
2	Supplements to ET 200SP documentation	33
2.1	System Manual	33
2.2	BaseUnits manual	34
2.2.1	Special consideration for BaseUnits with functional versions < 04	34
2.3	BusAdapter Equipment Manual	34
2.4	Interface module manuals	34
2.5	I/O module manuals	42
2.5.1	Digital module device manuals	44
2.5.2	Analog module device manuals	56
2.5.3	Communications module manuals	74
3	Using ET 200SP higher than 2 000 m above sea level	76
3.1	Ambient temperature and installation altitude	76
3.2	Listing of the modules	77
3.3	Restrictions	88

Module overview of ET 200SP

1.1 Module firmware corrected for R1 redundancy

A firmware update is required for some electronic modules to obtain the full compatibility for the ET 200SP R1 system. If an older firmware version of the module is used than the one specified below, a process data surge can occur during a redundancy switchover of the interface modules.

NOTE

All electronic modules not listed here do not require a firmware update to obtain full compatibility for the ET 200SP R1 system.

The following table shows which modules support a bumpless R1 switchover as of which firmware version:

Module	Article number	As of firmware version
F-CM AS-i Safety ST**	3RK7136-6SC00-0BC1	-
CM AS-i Master ST	3RK7137-6SA00-0BC1	V1.1.11
F-TM ServoDrive 1x24..48V ST	6BK1136-6AB00-0BU0	V1.3.0 or higher
F-TM ServoDrive 1x24..48V HF	6BK1136-6AB00-0CU0	V1.1.0 or higher
F-TM StepDrive 1x24..48V ST	6BK1136-6SB00-0BU0	V1.0.1 or higher
DI 8x24VDC BA*	6ES7131-6BF00-0AA0	-
DI 8x24VDC ST*	6ES7131-6BF00-0BA0	-
DI 8x24VDC SRC BA*	6ES7131-6BF60-0AA0	-
DI 16x24VDC ST*	6ES7131-6BH00-0BA0	-
DI 4x120..230VAC ST*	6ES7131-6FD00-0BB1	-
DI 8xNAMUR HF	6ES7131-6TF00-0CA0	V1.1***
DQ 8x24VDC/0,5A BA*	6ES7132-6BF00-0AA0	-
DQ 8x24VDC/0,5A ST*	6ES7132-6BF00-0BA0	-
DQ 8x24VDC/0,5A SNK BA*	6ES7132-6BF60-0AA0	-
DQ 16x24VDC/0,5A ST*	6ES7132-6BH00-0BA0	-
RQ 4x24VUC/2A CO ST*	6ES7132-6GD50-0BA0	-
RQ 4x24VUC...230VUC/5A*	6ES7132-6HD00-0BB1	-
AI 4xI 2-/4-wire ST*	6ES7134-6GD00-0BA1	-
AI 2xUI 2-/4-wire HF	6ES7134-6HB00-0CA1	V2.0.5
AI 2xUI 2-/4-wire HS	6ES7134-6HB00-0DA1	V2.0.3
AI 4xUI 2-wire ST*	6ES7134-6HD00-0BA1	-

* No firmware update is offered for these modules since there are compatible successor products

** No firmware update with the error correction is currently offered for these modules

1.1 Module firmware corrected for R1 redundancy

Module	Article number	As of firmware version
AI 4xRTD/TC 2-/3-/4-wire HF	6ES7134-6JD00-OCA1	V2.1.1
AI 4xTC HS	6ES7134-6JD00-ODA1	V1.0.3
AI 8xRTD/TC 2-wire HF	6ES7134-6JF00-OCA1	V2.1.1
AI Energy Meter*	6ES7134-6PA00-0BD0	-
AI Energy Meter 400VAC ST*	6ES7134-6PA01-0BD0	-
AI Energy Meter 480VAC ST*	6ES7134-6PA20-0BD0	-
AI Energy Meter 480VAC HF*	6ES7134-6PAx0-OCU0	-
AI4 x I HART	6ES7134-6TD00-OCA1	V1.1.1
AQ 2xUI HF	6ES7135-6HB00-OCA1	V1.0.3
AQ 2xUI HS	6ES7135-6HB00-ODA1	V2.0.4
AQ 4xUI ST	6ES7135-6HD00-OBA1	V1.1.3
AQ 4xI HART	6ES7135-6TD00-OCA1	V1.0.1
F-AI 4xI	6ES7136-6AA00-OCA1	V1.0.2
F-AI 4xU	6ES7136-6AB00-OCA1	V1.0.1
F-DI 8X24VDC HF	6ES7136-6BA00-OCA0	V1.0.7
F-DI 8X24VDC HF	6ES7136-6BA01-OCA0	V1.0.0
F-TM Count sin/cos 1x1Vpp HF	6ES7136-6CB00-OCA0	V1.0.0
F-DQ 4XDC 24V/2A	6ES7136-6DB00-OCA0	V2.0.2
F-DQ 8X 24VDC/0.5A PP	6ES7136-6DC00-OCA0	V1.0.1
F-PM-E PPM, 24V DC	6ES7136-6PA00-0BC0	-
CM PtP*	6ES7137-6AA00-OBA0	-
CM PtP	6ES7137-6AA01-OBA0	V2.0.0
CM 4xIO-Link	6ES7137-6BD00-OBA0	V2.2.2
CM DALI	6ES7137-6CA00-0BU0	V1.0.1
CM 1xCAN	6ES7137-6EA00-OBA0	V1.2***
TM Count 1x24V*	6ES7138-6AA00-OBA0	-
TM Count 1x24V	6ES7138-6AA01-OBA0	V2.0.2
TM PosInput 1*	6ES7138-6BA00-OBA0	-
TM PosInput 1	6ES7138-6BA01-OBA0	V2.0.1
TM Timer DIDQ 10x24V	6ES7138-6CG00-OBA0	V1.0.3
TM Pulse 2x24V	6ES7138-6DB00-0BB1	V1.0.2
TM ECC 2xPWM 12V ST*	6FE1242-6TM10-0BB1	-
AI 2x SG 4-/6-wire HS (DMS)	7MH4134-6LB00-ODA0	V1.0.2
SIWAREX WP321	7MH4138-6AA00-OBA0	V1.4.4
SIWAREX WP351	7MH4138-6BA00-OCU0	V1.1.0
Buerkert Ventile	AirLINE SP Typ 8647	V1.1.1
TM StepDrive 24-48V/5A**	PHYTRON 10020273	-

* No firmware update is offered for these modules since there are compatible successor products

** No firmware update with the error correction is currently offered for these modules

You can find the latest firmware versions for the modules on the Internet (<https://support.industry.siemens.com/cs/ww/en/view/109804718>).

You can find a description of how to update the firmware of the modules in the "Firmware update" section of the System Manual (<https://support.industry.siemens.com/cs/ww/en/view/58649293>).

1.2 Possible combinations of BaseUnits and I/O modules

Contents

This product information includes amendments and corrections to the documentation of the ET 200SP Distributed I/O System (<https://support.industry.siemens.com/cs/ww/en/view/109742709>).

Which I/O modules / motor starters fit on a BaseUnit?

The following table provides an overview of the I/O modules / motor starters that fit on the corresponding compatible BaseUnits:

Table 1-1 Possible combinations of BaseUnits and I/O modules

I/O module	BaseUnit BU15-		BaseUnit BU20-						Color-coded label for process terminals		
	BU type A0 P16+A1-0+2D P16+A0-+2D P16+A1-0+2B P16+A0-+2B	BU type A1 P16+A0-+12D/T P16+A0-+2D/T P16+A0-+12B/T P16+A0-+2B/T	BU type B0 P12+A4-+0B	BU type B1 P12+A0-+4B	BU type C0 P6+A2-+4D	BU type C1 P6+A2-+4B	BU type D0 P12+A-0+0B	BU type F0 P8+A4+-0B		BU type U0 P16+A0-+2D P16+A0-+2B	
Digital I/O modules											
DI 16x24VDC ST	✓									CC00	
DI 8x24VDC ST	✓									CC01	
DI 8x24VDC HF	✓									CC01	
DI 8x24VDC HS	✓									CC01	

1.2 Possible combinations of BaseUnits and I/O modules

I/O module	BaseUnit BU15-		BaseUnit BU20-							Color-coded label for process terminals	
	BU type A0 P16+A1-0+2D P16+A0-+2D P16+A1-0+2B P16+A0-+2B	BU type A1 P16+A0-+12D/T P16+A0-+2D/T P16+A0-+12B/T P16+A0-+2B/T	BU type B0 P12+A4-+0B	BU type B1 P12+A0-+4B	BU type C0 P6+A2-+4D	BU type C1 P6+A2-+4B	BU type D0 P12+A-0+0B	BU type F0 P8+A4+-0B	BU type U0 P16+A0-+2D P16+A0-+2B		
DI 8x24VDC BA	✓									CC01	
DI 8x24VDC SRC BA	✓									CC02	
DI 8xNAMUR HF	✓									CC01	
DI 4x120..230VAC ST				✓						CC41	
DQ 16x24VDC/0.5A ST	✓									CC00	
DQ 4x24VDC/2A ST	✓									CC02	
DQ 8x24VDC/0.5 ST	✓									CC02	
DQ 8x24VDC/0.5A HF	✓									CC02	
DQ 8x24VDC/0.5A BA	✓									CC02	
DQ 8x24VDC/0.5A SNK BA	✓									CC01	

1.2 Possible combinations of BaseUnits and I/O modules

I/O module	BaseUnit BU15-		BaseUnit BU20-							Color-coded label for process terminals	
	BU type A0 P16+A1-0+2D P16+A0-+2D P16+A1-0+2B P16+A0-+2B	BU type A1 P16+A0-+12D/T P16+A0-+2D/T P16+A0-+12B/T P16+A0-+2B/T	BU type B0 P12+A4-+0B	BU type B1 P12+A0-+4B	BU type C0 P6+A2-+4D	BU type C1 P6+A2-+4B	BU type D0 P12+A-0+0B	BU type F0 P8+A4+-0B	BU type U0 P16+A0-+2D P16+A0-+2B		
DQ 4x24...230VAC/2A ST				✓						CC41	
DQ 4x24...230VAC/2A HF				✓						---	---
DQ 4x24VDC/2A HF									✓	CC02	
DQ 4x24VDC/2A HS	✓									CC00	
RQ 4x24VUC/2A CO ST	✓									CC00	
RQ 4x120VDC-230VAC/5A NO ST			✓	✓						---	---
RQ 4x120VDC-230VAC/5A NO MA ST			✓	✓						---	---
RQ 3x120VDC-230VAC/5A CO ST									✓	---	---
RQ 3x120VDC-230VAC/5A CO n.i. ST									✓	---	---
Analog I/O modules											
AI 4xRTD/TC 2-/3-/4-wire HF	✓	✓								CC00	
AI 8xRTD/TC 2-wire HF	✓	✓								CC00	
AI 8xU BA	✓	✓								CC02	

1.2 Possible combinations of BaseUnits and I/O modules

I/O module	BaseUnit BU15-		BaseUnit BU20-							Color-coded label for process terminals	
	BU type A0 P16+A1-0+2D P16+A0-+2D P16+A1-0+2B P16+A0-+2B	BU type A1 P16+A0-+12D/T P16+A0-+2D/T P16+A0-+12B/T P16+A0-+2B/T	BU type B0 P12+A4-+0B	BU type B1 P12+A0-+4B	BU type C0 P6+A2-+4D	BU type C1 P6+A2-+4B	BU type D0 P12+A-0+0B	BU type F0 P8+A4+-0B	BU type U0 P16+A0-+2D P16+A0-+2B		
AI 2xU ST	✓	✓								CC00	
AI 2xI 2-/4-wire ST	✓	✓								CC05	
AI 4xU/I 2-wire ST	✓	✓								CC03	
AI 4xTC HS	✓	✓								CC00	
AI 2xU/I 2-/4-wire HF	✓	✓								CC05	
AI 2xU/I 2-/4-wire HS	✓	✓								CC00	
AI 2xSG 4-/6-wire HS	✓									CC00	
AI 8xI 2-/4-wire BA	✓	✓								CC01	
AI 4xI 2-/4-wire ST	✓	✓								CC03	
AI 4xI 2-wire 4...20mA HART	✓	✓								CC03	

1.2 Possible combinations of BaseUnits and I/O modules

I/O module	BaseUnit BU15-		BaseUnit BU20-							Color-coded label for process terminals	
	BU type A0 P16+A1-0+2D P16+A0-+2D P16+A1-0+2B P16+A0-+2B	BU type A1 P16+A0-+12D/T P16+A0-+2D/T P16+A0-+12B/T P16+A0-+2B/T	BU type B0 P12+A4-+0B	BU type B1 P12+A0-+4B	BU type C0 P6+A2-+4D	BU type C1 P6+A2-+4B	BU type D0 P12+A-0+0B	BU type F0 P8+A4+-0B	BU type U0 P16+A0-+2D P16+A0-+2B		
AQ 2xU ST	✓	✓								CC00	
AQ 2xI ST	✓	✓								CC00	
AQ 4xU/I ST	✓	✓								CC00	
AQ 4xI HART HF	✓	✓								CC00	
AQ 2xU/I HS	✓	✓								CC00	
AQ 2xU/I HF	✓	✓								CC00	
AI Energy Meter 400VAC ST							✓			CC20	Only systematic, but cannot be ordered
AI Energy Meter 480VAC ST							✓			CC20	
AI Energy Meter 480VAC/CT HF									✓	CC20	
AI Energy Meter 480VAC/RC HF									✓	CC20	
AI Energy Meter CT ST									✓	CC20	
AI Energy Meter RC ST									✓	CC20	
AI Energy Meter CT HF									✓	CC20	
AI Energy Meter RC HF									✓	CC20	

1.2 Possible combinations of BaseUnits and I/O modules

I/O module	BaseUnit BU15-		BaseUnit BU20-							Color-coded label for process terminals	
	BU type A0 P16+A1-0+2D P16+A0-+2D P16+A1-0+2B P16+A0-+2B	BU type A1 P16+A0-+12D/T P16+A0-+2D/T P16+A0-+12B/T P16+A0-+2B/T	BU type B0 P12+A4-+0B	BU type B1 P12+A0-+4B	BU type C0 P6+A2-+4D	BU type C1 P6+A2-+4B	BU type D0 P12+A-0+0B	BU type F0 P8+A4+-0B	BU type U0 P16+A0-+2D P16+A0-+2B		
Fail-safe modules											
F-PM-E 24VDC/8A PPM ST					✓					CC52	
F-DI 8x24VDC HF	✓									CC01	
F-DQ 4x24VDC/2A PM HF	✓									CC02	
F-DQ 8x24VDC/0.5A PP HF	✓									CC02	
F-RQ 1x24VDC/2-4..230VAC/5A							✓			CC42	
F-AI 4xI 0(4)..20mA 2-/4-wire HF	✓	✓								CC00	
F-AI 4xU 0..10V HF	✓	✓								CC00	
F-TM Count 1x1Vpp sin/cos HF	✓									CC01	
F-TM ServoDrive ST 1x24 ... 48 V								✓		---	---
F-TM StepDrive ST 1x24..48V 5A								✓		---	---
Communication modules											
CM 4xIO-Link	✓									CC04	

1.2 Possible combinations of BaseUnits and I/O modules



I/O module	BaseUnit BU15-		BaseUnit BU20-							Color-coded label for process terminals	
	BU type A0 P16+A1-0+2D P16+A0-+2D P16+A1-0+2B P16+A0-+2B	BU type A1 P16+A0-+12D/T P16+A0-+2D/T P16+A0-+12B/T P16+A0-+2B/T	BU type B0 P12+A4-+0B	BU type B1 P12+A0-+4B	BU type C0 P6+A2-+4D	BU type C1 P6+A2-+4B	BU type D0 P12+A-0+0B	BU type F0 P8+A4+-0B	BU type U0 P16+A0-+2D P16+A0-+2B		
CM AS-i Master ST					✓					---	---
F-CM AS-i Safety ST					✓	✓				---	---
CM PtP	✓									---	---
CM 1xDALI									✓	---	---
CM 1xCAN ST	✓									---	---
Technology modules											
TM Count 1x24V	✓									---	---
TM PosInput 1	✓									---	---
TM Timer DIDQ 10x24V	✓									---	---
TM Pulse 2x24V				✓						---	---
SIWAREX WP321	✓									---	---
SIWAREX WP351 HF									✓	CC00	
F-TM ServoDrive ST 1x24 ... 48 V									✓	---	---
F-TM StepDrive ST 1x24..48V 5A									✓	---	---
TM FCT070				✓						---	---
F-TM Count 1x1Vpp sin/cos HF	✓									CC01	

Table 1-2 Possible combinations of Ex BaseUnits and I/O modules

Ex I/O modules	BaseUnit	
	for Ex I/O modules	for Ex power module
Ex-DI 4xNAMUR	✓	
Ex-DQ 2x17.4VDC/27mA	✓	
Ex-DQ 2x23.1VDC/20mA	✓	
Ex-AQ 2xI HART	✓	

1.2 Possible combinations of BaseUnits and I/O modules

Ex I/O modules	BaseUnit	
	for Ex I/O modules	for Ex power module
Ex-AI 2xI 2-wire HART	✓	
Ex-AI 4xTC/2xRTD 2-/3-/4-wire	✓	
Ex-PM E		✓

Table 1-3 Possible combinations of BaseUnits and motor starters

	Selecting the BaseUnit										
	BU-30--MS1	BU-30--MS2	BU-30--MS3	BU-30--MS4	BU-30--MS5	BU-30--MS6	BU-30--MS7	BU-30--MS8	BU-30--MS9	BU-30--MS10	
24 V infeed	x		x								
500 V infeed	x	x			x		x	x			
(no routing of the F-DI signal possible)F-DI terminals					x	x					
F-DI infeed							x			x	
F-DI routing								x	x		
Motor starters											
DS 0.1 - 0.4 A HF	3RK1308-OA-A00-OCPO	x	x	x	x	x*	x*	x*	x*	x*	x*
DS 0.3 - 1 A HF	3RK1308-OA-B00-OCPO	x	x	x	x	x*	x*	x*	x*	x*	x*
DS 0.9 - 3 A HF	3RK1308-OA-C00-OCPO	x	x	x	x	x*	x*	x*	x*	x*	x*
DS 2.8 - 9 A HF	3RK1308-OA-D00-OCPO	x	x	x	x	x*	x*	x*	x*	x*	x*
DS 4.0 - 12 A HF	3RK1308-OAE-00-OCPO	x	x	x	x	x*	x*	x*	x*	x*	x*
RS 0.1 - 0.4 A HF	3RK1308-OB-A00-OCPO	x	x	x	x	x*	x*	x*	x*	x*	x*
RS 0.3 - 1 A HF	3RK1308-OB-00-OCPO	x	x	x	x	x*	x*	x*	x*	x*	x*
RS 0.9 - 3 A HF	3RK1308-OB-00-OCPO	x	x	x	x	x*	x*	x*	x*	x*	x*
RS 2.8 - 9 A HF	3RK1308-OB-D00-OCPO	x	x	x	x	x*	x*	x*	x*	x*	x*
RS 4.0 - 12 A HF	3RK1308-OB-E00-OCPO	x	x	x	x	x*	x*	x*	x*	x*	x*
F-DS 0.1 - 0.4 A HF	3RK1308-OC-A00-OCPO	x	x	x	x	x	x	x	x	x	x
F-DS 0.3 - 1 A HF	3RK1308-OC-B00-OCPO	x	x	x	x	x	x	x	x	x	x
F-DS 0.9 - 3 A HF	3RK1308-OC-C00-OCPO	x	x	x	x	x	x	x	x	x	x

* The F-DI terminals or F-DI infeed/routing have no function with this combination.

F-DS 2.8 - 9 A HF	3RK1308-0C-D00-0CP0	x	x	x	x	x	x	x	x	x	x
F-DS 4.0 - 12 A HF	3RK1308-0CE-00-0CP0	x	x	x	x	x	x	x	x	x	x
F-RS 0.1 - 0.4 A HF	3RK1308-0D-A00-0CP0	x	x	x	x	x	x	x	x	x	x
F-RS 0.3 - 1 A HF	3RK1308-0D-B00-0CP0	x	x	x	x	x	x	x	x	x	x
F-RS 0.9 - 3 A HF	3RK1308-0D-C00-0CP0	x	x	x	x	x	x	x	x	x	x
F-RS 2.8 - 9 A HF	3RK1308-0D-D00-0CP0	x	x	x	x	x	x	x	x	x	x
F-RS 4.0 - 12 A HF	3RK1308-0D-E00-0CP0	x	x	x	x	x	x	x	x	x	x

* The F-DI terminals or F-DI infeed/routing have no function with this combination.

Table 1-4 Combination possibilities between potential distributor BaseUnit and potential distributor terminal block

Potential distributor terminal block	Potential distributor BaseUnit			
	PotDis-BU-P1/D-R	PotDis-BU-P1/B-R	PotDis-BU-P2/D-B	PotDis-BU-P2/B-B
PotDis-TB-P1-R	✓	✓	✓	✓
PotDis-TB-P2-B	✓	✓	✓	✓
PotDis-TB-n.c.-G	✓	✓	✓	✓
PotDis-TB-BR-W	✓	✓	✓	✓

1.3 CPUs

CPUs

CPU	Packing unit	Article number
CPU 1510SP-1 PN with server module	Pack of 1	6ES7510-1Dx0x-0AB0
CPU 1510SP F-1 PN with server module	Pack of 1	6ES7510-1Sx0x-0AB0
CPU 1512SP-1 PN with server module	Pack of 1	6ES7512-1Dx0x-0AB0
CPU 1512SP F-1 PN with server module	Pack of 1	6ES7512-1Sx0x-0AB0
CPU 1514SP-2 PN with server module	Pack of 1	6ES7514-2DN03-0AB0
CPU 1514SP F-2 PN with server module	Pack of 1	6ES7514-2SN03-0AB0
CPU 1514SP T-2 PN with server module	Pack of 1	6ES7514-2VN03-0AB0
CPU 1514SP TF-2 PN with server module	Pack of 1	6ES7514-2WN03-0AB0
CPU 1515SP PC with server module	Pack of 1	6ES7677-2AAxx-0xx0

1.3 CPUs

Important differences between the CPUs...PN up to firmware version 2.9				
Features	CPU 1510SP-1 PN	CPU 1510SP F-1 PN	CPU 1512SP-1 PN	CPU 1512SP F-1 PN
Bus connection	PROFINET: BusAdapter (X1 Port 1, 2) <ul style="list-style-type: none"> • BA 2xRJ45 (as of firmware version 1.6) • BA 2xFC (as of firmware version V1.6) • BA 2xM12 (as of firmware V2.8)¹ RJ45, integrated (X1 Port 3)		PROFINET: BusAdapter (X1 Port 1, 2) <ul style="list-style-type: none"> • BA 2xRJ45 (as of firmware version 1.6) • BA 2xFC (as of firmware version V1.6) • BA 2xSCRJ (as of firmware V1.8)² • BA SCRJ/RJ45 (as of firmware V1.8)² • BA SCRJ/FC (as of firmware V1.8)² • BA 2xLC (as of firmware V2.0)² • BA LC/RJ45 (as of firmware V2.0)² • BA LC/FC (as of firmware V2.0)² • BA 2xM12 (as of firmware V2.8)² RJ45, integrated (X1 Port 3)	
	PROFIBUS: PROFIBUS DP connection socket via CM DP communications module			
Number of modules	64			
Data work memory	750 KB		1 MB	
Code work memory	100 KB	150 KB	200 KB	300 KB
Address space	1280 bytes/2560 bytes ³			
Multi hot-swapping	Yes			
Can be used for safety applications (supports PROFIsafe V2.0)	No	Yes	No	Yes

¹ Only with article numbers 6ES7510-1DJ01-0AB0 and 6ES7510-1SJ01-0AB0

² Only with article numbers 6ES7512-1DK01-0AB0 and 6ES7512-1SK01-0AB0

³ Only 6ES7510-1DJ01-0AB0, 6ES7512-1SJ01-0AB0, 6ES7512-1DK01-0AB0 and 6ES7512-1SK01-0AB0 with FW version V2.0

Important differences between the CPUs...PN as of firmware version 3.0								
Features	CPU 1510SP-1 PN	CPU 1510SP F-1 PN	CPU 1512SP-1 PN	CPU 1512SP F-1 PN	CPU 1514SP-2 PN	CPU 1514SP F-2 PN	CPU 1514SP T-2 PN	CPU 1514SP TF-2 PN
Bus connection	PROFINET: BusAdapter (X1 Port 1, 2) <ul style="list-style-type: none"> • BA 2xRJ45 • BA 2xFC • BA 2xM12 RJ45, integrated (X1 Port 3 or X2 Port 1)							
	PROFIBUS: PROFIBUS DP connection socket via CM DP communications module							
Number of modules	64							
Data work memory	1 MB		2 MB		3.5 MB			
Code work memory	200 KB	300 KB	400 KB	600 KB	600 KB	900 KB		

Important differences between the CPUs...PN as of firmware version 3.0								
Features	CPU 1510SP-1 PN	CPU 1510SP F-1 PN	CPU 1512SP-1 PN	CPU 1512SP F-1 PN	CPU 1514SP-2 PN	CPU 1514SP F-2 PN	CPU 1514SP T-2 PN	CPU 1514SP TF-2 PN
Address space	2560 bytes							
Multi hot-swapping	Yes							
Can be used for safety applications (supports PROFIsafe V2.0)	No	Yes	No	Yes	No	Yes	No	Yes

Important differences between CPUs... PN from firmware version 3.1								
Features	CPU 1510SP-1 PN	CPU 1510SP F-1 PN	CPU 1512SP-1 PN	CPU 1512SP F-1 PN	CPU 1514SP-2 PN	CPU 1514SP F-2 PN	CPU 1514SP T-2 PN	CPU 1514SP TF-2 PN
Bus connection	PROFINET: BusAdapter (X1 Port 1, 2) <ul style="list-style-type: none"> • BA 2xRJ45 • BA 2xFC • BA 2xM12 • BA SCRJ/RJ45 • BA LC/RJ45 • BA 2xSCRJ • BA SCRJ/FC • BA 2xLC • BA LC/FC RJ45, integrated (X1 Port 3 or X2 Port 1)							
	PROFIBUS: PROFIBUS DP connection socket via CM DP communications module							
Number of modules	64							
Data work memory	1 MB		2 MB		3.5 MB			
Code work memory	200 KB	300 KB	400 KB	600 KB	600 KB	900 KB		
Address space	2560 bytes							
Multi hot-swapping	Yes							
Can be used for safety applications (supports PROFIsafe V2.0)	No	Yes	No	Yes	No	Yes	No	Yes

1.4 Interface modules

NOTE

The CM AS-i master ST and F-CM AS-i Safety ST communications modules are supported as of firmware V1.8 of the CPUs. Note the following additional requirements:

CM AS-i master ST:

- Firmware version of the CM AS-i master ST: V1.1
- STEP 7 (TIA Portal): V13 SP1 Update 4 or higher

F-CM AS-i Safety ST

- Firmware version of the CM AS-i Safety ST: V1.0
- STEP 7 (TIA Portal): as of V13 SP1 Update 4 and HSP0070 V3.0

1.4 Interface modules

Interface modules

Interface modules	Packing unit	Article number
Interface module IM 155-6 PN BA	Pack of 1	6ES7155-6AR00-0AN0
Interface module IM 155-6 PN ST		
• with BusAdapter BA 2xRJ45 and server module	Pack of 1	6ES7155-6AA02-0BN0
• with server module	Pack of 1	6ES7155-6AU02-0BN0
Interface module IM 155-6 PN/2 HF with server module	Pack of 1	6ES7155-6AU01-0CN0
Interface module IM 155-6 PN/3 HF with server module	Pack of 1	6ES7155-6AU30-0CN0
Interface module IM 155-6 PN R1 with server module	Pack of 1	6ES7155-6AU00-0HM0
Interface module IM 155-6 MF HF with server module	Pack of 1	6ES7155-6MU00-0CN0
Interface module IM 155-6 PN HS with server module	Pack of 1	6ES7155-6AU00-0DN0
Interface module IM 155-6 DP HF with PROFIBUS FastConnect bus connector (6ES7972-0BB70-0XA0) and server module	Pack of 1	6ES7155-6BA01-0CN0

Important differences between the interface modules						
Features	IM 155-6 PN BA	IM 155-6 PN ST	IM 155-6 PN/2 HF IM 155-6 PN/3 HF	IM 155-6 MF HF	IM 155-6 PN HS	IM 155-6 DP HF
Bus connection	PROFINET: 2xRJ45, integrated	PROFINET: BusAdapter <ul style="list-style-type: none"> • BA 2xRJ45 (as of firmware V1.0) • BA 2xFC (as of firmware V1.0) • BA 2xM12 (as of firmware V4.2) 	PROFINET:	PROFINET, EtherNet/IP, Modbus TCP:	PROFINET:	PROFIBUS: PROFIBUS DP connection socket

Important differences between the interface modules						
Features	IM 155-6 PN BA	IM 155-6 PN ST	IM 155-6 PN/2 HF IM 155-6 PN/3 HF	IM 155-6 MF HF	IM 155-6 PN HS	IM 155-6 DP HF
			BusAdapter <ul style="list-style-type: none"> • BA 2xRJ45 (as of firmware V2.0) • BA 2xFC (as of firmware V2.0) • BA 2xSCRJ (as of firmware V2.2) • BA SCRJ/RJ45 (as of firmware V3.1) • BA SCRJ/FC (as of firmware V3.1) • BA 2xLC (as of firmware V3.3) • BA LC/RJ45 (as of firmware V3.3) • BA LC/FC (as of firmware V3.3) • BA 2xM12 (as of firmware V4.2) 	BusAdapter <ul style="list-style-type: none"> • BA 2xRJ45 • BA 2xM12 (as of firmware V5.0) • BA 2xFC • BA 2xLC • BA 2xSCRJ • BA SCRJ/RJ45 • BA SCRJ/FC • BA LC/RJ45 • BA LC/FC 	BusAdapter <ul style="list-style-type: none"> • BA 2xRJ45 (as of firmware V4.0) • BA 2xFC (as of firmware V4.0) • BA 2xSCRJ (as of firmware V4.0) • BA SCRJ/RJ45 (as of firmware V4.0) • BA SCRJ/FC (as of firmware V4.0) • BA 2xLC (as of firmware V4.0) • BA LC/RJ45 (as of firmware V4.0) • BA LC/FC (as of firmware V4.0) 	
Number of modules	12	32	64	64	30	32
RESET button	No	Yes	Yes	Yes	Yes	Not necessary
Address space (I/O data)	32 bytes	1440 bytes	1440 bytes	1440 bytes	968 bytes	244 bytes
Multi hot-swapping	No	Yes	Yes	Yes	Yes	Yes

Table 1-5 Station expansion via ET-Connection (mixed configuration ET 200SP/ET 200AL)

Modules	Packing unit	Article number
BU-Send	Pack of 1	6ES7193-6BN00-0NE0
BA-Send 1xFC	Pack of 1	6ES7193-6AS00-0AA0

1.5 BusAdapter

BusAdapter

BusAdapter	Packing unit	Article number
• BA 2xRJ45 (PROFINET BusAdapter with standard Ethernet socket)	Pack of 1	6ES7193-6AR00-0AA0
• BA 2xM12 (PROFINET BusAdapter with M12 Ethernet socket)	Pack of 1	6ES7193-6AM00-0AA0
• BA 2xFC (PROFINET BusAdapter with FastConnect Ethernet connection)	Pack of 1	6ES7193-6AF00-0AA0
• BA 2xSCRJ (PROFINET BusAdapter with POF/PCF fiber-optic cable connection)	Pack of 1	6ES7193-6AP00-0AA0
• BA SCRJ/RJ45 (media converter, PROFINET BusAdapter with fiber-optic cable FOC ↔ standard RJ45 connector)	Pack of 1	6ES7193-6AP20-0AA0
• BA SCRJ/FC (media converter, PROFINET BusAdapter with fiber-optic cable FOC ↔ direct connection of bus cable)	Pack of 1	6ES7193-6AP40-0AA0
• BA 2xLC (PROFINET BusAdapter with glass fiber-optic cable connection multi-mode)	Pack of 1	6ES7193-6AG00-0AA0
• BA LC/RJ45 (media converter, PROFINET BusAdapter with glass fiber-optic cable ↔ standard RJ45 connector)	Pack of 1	6ES7193-6AG20-0AA0
• BA LC/FC (media converter, PROFINET BusAdapter with glass fiber-optic cable ↔ direct connection of bus cable)	Pack of 1	6ES7193-6AG40-0AA0
• BA 2xLC-LD (PROFINET BusAdapter with single-mode glass fiber-optic cable connection, long distance)	Pack of 1	6ES7193-6AG50-0AA0
• BA LC-LD/RJ45 (media converter, PROFINET BusAdapter with single-mode glass fiber-optic connection, long distance ↔ standard RJ45 connector)	Pack of 1	6ES7193-6AG60-0AA0
• BA LC-LD/M12 (media converter, PROFINET BusAdapter with single-mode glass fiber-optic connection, long distance ↔ M12 Ethernet socket)	Pack of 1	6ES7193-6AG70-0AA0

1.6 BaseUnits

BaseUnits

Table 1-6 BaseUnits for I/O modules

BU type	BaseUnits (short name)	Color-coded labels*	Packing unit	Article number
A0	BU15-P16+A10+2D	P16: CC00 to CC05 A10: CC71 to CC73	Pack of 1	6ES7193-6BP20-0DA0
			Pack of 10	6ES7193-6BP20-2DA0
A0	BU15-P16+A0+2D	P16: CC00 to CC05	Pack of 1	6ES7193-6BP00-0DA0
			Pack of 10	6ES7193-6BP00-2DA0
A0	BU15-P16+A10+2B	P16: CC00 to CC05 A10: CC71 to CC73	Pack of 1	6ES7193-6BP20-0BA0
			Pack of 10	6ES7193-6BP20-2BA0
A0	BU15-P16+A0+2B	P16: CC00 to CC05	Pack of 1	6ES7193-6BP00-0BA0

* not included in the scope of delivery of the BaseUnit

BU type	BaseUnits (short name)	Color-coded labels*	Packing unit	Article number
A0	BU15-P16+A0+2B	P16: CC00 to CC05	Pack of 10	6ES7193-6BP00-2BA0
A1	BU15-P16+A0+12D/T	P16: CC00 to CC05 12D: CC74	Pack of 1	6ES7193-6BP40-0DA1
A1	BU15-P16+A0+2D/T	P16: CC00 to CC05	Pack of 1	6ES7193-6BP00-0DA1
A1	BU15-P16+A0+12B/T	P16: CC00 to CC05 12B: CC74	Pack of 1	6ES7193-6BP40-0BA1
A1	BU15-P16+A0+2B/T	P16: CC00 to CC05	Pack of 1	6ES7193-6BP00-0BA1
B0	BU20-P12+A4+0B	A4: CC81 to CC83	Pack of 1	6ES7193-6BP20-0BB0
			Pack of 10	6ES7193-6BP20-2BB0
B1	BU20-P12+A0+4B	P12: CC41	Pack of 1	6ES7193-6BP20-0BB1
			Pack of 10	6ES7193-6BP20-2BB1
C0	BU20-P6+A2+4D	P6: CC51, CC52 A2: CC84 to CC86	Pack of 1	6ES7193-6BP20-0DC0
C1	BU20-P6+A2+4B	P6: CC51 A2: CC84 to CC86	Pack of 1	6ES7193-6BP20-0BC1
D0	BU20-P12+A0+0B	---	Pack of 1	6ES7193-6BP00-0BD0
F0	BU20-P8+A4+0B	P8: CC42	Pack of 1	6ES7193-6BP20-0BF0
U0	BU20-P16+A0+2D	P16: CC00 to CC05	Pack of 1	6ES7193-6BP00-0BU0
			Pack of 10	6ES7193-6BP00-2BU0
U0	BU20-P16+A0+2B	P16: CC00 to CC05	Pack of 1	6ES7193-6BP00-0DU0
			Pack of 10	6ES7193-6BP00-2DU0

* not included in the scope of delivery of the BaseUnit

Table 1-7 BaseUnit Ex I/O modules

BU type	Ex BaseUnits	Color-coded labels	Packing unit	Article number
W0	for Ex power module	-	Pack of 1	6DL1193-6BP00-0DW0
X1	for Ex I/O modules	-	Pack of 1	6DL1193-6BP00-0BX1

Table 1-8 BaseUnit PotDis

PotDis type	Potential distributor (short name)	Color-coded labels	Packing unit	Article number
P1	PotDis-BU-P1/D-R	CC62	Pack of 1	6ES7193-6UP00-ODP1
P1	PotDis-BU-P1/B-R	CC62	Pack of 1	6ES7193-6UP00-0BP1
P2	PotDis-BU-P2/D-B	CC63	Pack of 1	6ES7193-6UP00-ODP2
P2	PotDis-BU-P2/B-B	CC63	Pack of 1	6ES7193-6UP00-0BP2

1.7 I/O modules

Table 1-9 BaseUnit PotDis-TB

Terminal block type	Terminal block (short name)	Color-coded labels	Packing unit	Article number
P1	PotDis-TB-P1-R	CC12	Pack of 1	6ES7193-6TP00-0TP1
P2	PotDis-TB-P2-B	CC13	Pack of 1	6ES7193-6TP00-0TP2
N0	PotDis-TB-n.c.-G	CC10	Pack of 1	6ES7193-6TP00-0TN0
P0	PotDis-TB-BR-W	CC10 to CC13	Pack of 1	6ES7193-6TP00-0TP0

Table 1-10 BaseUnits for motor starters

BU type	BaseUnits (short name)	Color-coded labels	Packing unit	Article number
MS1	BU30-MS1	-	Pack of 1	3RK1908-0AP00-0APO
MS2	BU30-MS2	-	Pack of 1	3RK1908-0AP00-0CPO
MS3	BU30-MS3	-	Pack of 1	3RK1908-0AP00-0BPO
MS4	BU30-MS4	-	Pack of 1	3RK1908-0AP00-0DPO
MS5	BU30-MS5	-	Pack of 1	3RK1908-0AP00-0EPO
MS6	BU30-MS6	-	Pack of 1	3RK1908-0AP00-0FPO
MS7	BU30-MS7	-	Pack of 1	3RK1908-0AP00-0GPO
MS8	BU30-MS8	-	Pack of 1	3RK1908-0AP00-0HPO
MS9	BU30-MS9	-	Pack of 1	3RK1908-0AP00-0JPO
MS10	BU30-MS10	-	Pack of 1	3RK1908-0AP00-0KPO

Table 1-11 BaseUnit interface module

BU type	Interface module	Color-coded labels	Packing unit	Article number
M0	IM 155-6 PN R1	-	Pack of 1	6ES7193-6BR00-0HMO

1.7 I/O modules

I/O modules

Digital I/O modules	Coding element type	Packing unit	Article number
DI 16x24VDC ST	A	Pack of 1	6ES7131-6BH01-0BA0
		Pack of 10	6ES7131-6BH01-2BA0
DI 8x24VDC ST	A	Pack of 1	6ES7131-6BF01-0BA0
		Pack of 10	6ES7131-6BF01-2BA0
DI 8x24VDC HF	A	Pack of 1	6ES7131-6BF00-0CA0
		Pack of 10	6ES7131-6BF00-2CA0
DI 8x24VDC HS	A	Pack of 1	6ES7131-6BF00-0DA0
DI 8xNAMUR HF	A	Pack of 1	6ES7131-6TF00-0CA0
DI 8x24VDC BA	A	Pack of 1	6ES7131-6BF01-0AA0
		Pack of 10	6ES7131-6BF01-2AA0
DI 8x24VDC SRC BA	B	Pack of 1	6ES7131-6BF61-0AA0

Digital I/O modules	Coding element type	Packing unit	Article number
DI 8x24VAC/48VUC BA	C	Pack of 1	6ES7131-6CF00-0AU0
DI 4x120..230VAC ST	C	Pack of 1	6ES7131-6FD01-0BB1
DQ 16x24VDC/0.5A ST	A	Pack of 1	6ES7132-6BH01-0BA0
		Pack of 10	6ES7132-6BH01-2BA0
DQ 16x24VDC/0.5A BA	A	Pack of 1	6ES7132-6BH00-0AA0
		Pack of 10	6ES7132-6BH00-2AA0
DQ 8x24VDC/0.5A ST	A	Pack of 1	6ES7132-6BF01-0BA0
		Pack of 10	6ES7132-6BF01-2BA0
DQ 8x24VDC/0.5A HF	A	Pack of 1	6ES7132-6BF00-0CA0
		Pack of 10	6ES7132-6BF00-2CA0
DQ 8x24VDC/0.5A BA	A	Pack of 1	6ES7132-6BF01-0AA0
		Pack of 10	6ES7132-6BF01-2AA0
DQ 8x24VDC/0.5A SNK BA	B	Pack of 1	6ES7132-6BF61-0AA0
DQ 4x24VDC/2A ST	A	Pack of 1	6ES7132-6BD20-0BA0
		Pack of 10	6ES7132-6BD20-2BA0
DQ 4x24..230VAC/2A ST	C	Pack of 1	6ES7132-6FD00-0BB1
		Pack of 10	6ES7132-6FD00-2BB1
DQ 4x24..230VAC/2A HF	C	Pack of 1	6ES7132-6FD00-0CU0
DQ 4x24VDC/2A HF	A	Pack of 1	6ES7132-6BD20-0CA0
DQ 4x24VDC/2A HS	A	Pack of 1	6ES7132-6BD20-0DA0
RQ 4x24VUC/2A CO ST	C	Pack of 1	6ES7132-6GD51-0BA0
RQ 4x120VDC-230VAC/5A NO ST	C	Pack of 1	6ES7132-6HD01-0BB1
		Pack of 10	6ES7132-6HD01-2BB1
RQ 4x120VDC-230VAC/5A NO MA ST	C	Pack of 1	6ES7132-6MD00-0BB1
RQ 3x120VDC-230VAC/5A CO ST	C	Pack of 1	6ES7132-6HC50-0BU0
RQ 3x120VDC-230VAC/5A CO n.i. ST	C	Pack of 1	6ES7132-6HC70-0BU0

Analog I/O modules	Coding element type	Packing unit	Article number
AI 8xU BA	B	Pack of 1	6ES7134-6FF00-0AA1
AI 2xU ST	A	Pack of 1	6ES7134-6FB00-0BA1
AI 4xU/I 2-wire ST	A	Pack of 1	6ES7134-6HD01-0BA1
		Pack of 10	6ES7134-6HD01-2BA1
AI 2xU/I 2-/4-wire HF	A	Pack of 1	6ES7134-6HB00-0CA1
AI 2xU/I 2-/4-wire HS	A	Pack of 1	6ES7134-6HB00-0DA1
AI 2xSG 4-/6-wire HS	A	Pack of 1	7MH4134-6LB00-0DA0
AI 8xl 2-/4-wire BA	A	Pack of 1	6ES7134-6GF00-0AA1
AI 2xl 2-/4-wire ST	A	Pack of 1	6ES7134-6GB00-0BA1
AI 4xl 2-/4-wire ST	A	Pack of 1	6ES7134-6GD01-0BA1
		Pack of 10	6ES7134-6GD01-2BA1
AI 8xRTD/TC 2-wire HF	A	Pack of 1	6ES7134-6JF00-0CA1

1.7 I/O modules

Analog I/O modules	Coding element type	Packing unit	Article number
AI 8xRTD/TC 2-wire HF	A	Pack of 10	6ES7134-6JF00-2CA1
AI 4xRTD/TC 2-/3-/4-wire HF	A	Pack of 1	6ES7134-6JD00-0CA1
		Pack of 10	6ES7134-6JD00-2CA1
AI 4xTC HS	A	Pack of 1	6ES7134-6JD00-0DA1
AI 4xI 2-wire 4...20mA HART	A	Pack of 1	6ES7134-6TD00-0CA1
AQ 2xU ST	A	Pack of 1	6ES7135-6FB00-0BA1
AQ 2xI ST	A	Pack of 1	6ES7135-6GB00-0BA1
AQ 4xU/I ST	A	Pack of 1	6ES7135-6HD00-0BA1
AQ 4xI HART HF	A	Pack of 1	6ES7135-6TD00-0CA1
AQ 2xU/I HF	A	Pack of 1	6ES7135-6HB00-0CA1
AQ 2xU/I HS	A	Pack of 1	6ES7135-6HB00-0DA1
AI Energy Meter CT HF	C	Pack of 1	6ES7134-6PA01-0CU0
AI Energy Meter RC HF	C	Pack of 1	6ES7134-6PA21-0CU0
AI Energy Meter CT ST	C	Pack of 1	6ES7134-6PA01-0BU0
AI Energy Meter RC ST	C	Pack of 1	6ES7134-6PA21-0BU0

Fail-safe modules	Coding element type	Packing unit	Article number
F-PM-E 24VDC/8A PPM ST	F	Pack of 1	6ES7136-6PA00-0BC0
F-DI 8x24VDC HF	F	Pack of 1	6ES7136-6BA01-0CA0
F-DQ 4x24VDC/2A PM HF	F	Pack of 1	6ES7136-6DB00-0CA0
F-DQ 8x24VDC/0.5A PP HF	F	Pack of 1	6ES7136-6DC00-0CA0
F-RQ 1x24VDC/24..230VAC/5A	C	Pack of 1	6ES7136-6RA00-0BF0
F-AI 4xI 0(4)..20mA 2-/4-wire HF	F	Pack of 1	6ES7136-6AA00-0CA1
F-AI 4xU 0..10V HF	H	Pack of 1	6ES7136-6AB00-0CA1
F-TM ServoDrive ST 1x24V..48V		Pack of 1	6BK1136-6AB00-0BU0
F-TM ServoDrive HF 1x24..48V 5A		Pack of 1	6BK1136-6AB00-0CU0
F-TM StepDrive ST 1x24..48V 5A		Pack of 1	6BK1136-6SB00-0BU0
F-TM Count 1x1Vpp sin/cos HF	H	Pack of 1	6ES7136-6CB00-0CA0
F-CM AS-i Safety ST	H	Pack of 1	3RK7136-6SC00-0BC1

Communications modules	Coding element type	Packing unit	Article number
CM 4xIO-Link	H	Pack of 1	6ES7137-6BD00-0BA0
CM AS-i Master ST	D	Pack of 1	3RK7137-6SA00-0BC1
F-CM AS-i Safety ST	H	Pack of 1	3RK7136-6SC00-0BC1
CM PtP	D	Pack of 1	6ES7137-6AA01-0BA0
		Pack of 10	6ES7137-6AA01-2BA0
CM DP (for CPU)		Pack of 1	6ES7545-5DA00-0AB0
CM 1xDALI	D	Pack of 1	6ES7137-6CA00-0BU0
CM 1xCAN ST	C	Pack of 1	6ES7137-6EA00-0BA0

Technology module	Coding element type	Packing unit	Article number
TM Count 1x24V	B	Pack of 1	6ES7138-6AA01-0BA0
		Pack of 10	6ES7138-6AA01-2BA0
TM PosInput 1	B	Pack of 1	6ES7138-6BA01-0BA0
		Pack of 10	6ES7138-6BA01-2BA0
TM PTO 2x24V		Pack of 1	6ES7138-6EB00-0BA0
TM Timer DIDQ 10x24V	B	Pack of 1	6ES7138-6CG00-0BA0
TM Pulse 2x24V	C	Pack of 1	6ES7138-6DB00-0BB1
SIWAREX WP321	B	Pack of 1	7MH4138-6AA00-0BA0
SIWAREX WP351 HF	B	Pack of 1	7MH4138-6BA00-0CU0
F-TM ServoDrive ST 1x24V..48V		Pack of 1	6BK1136-6AB00-0BU0
F-TM ServoDrive HF 1x24..48V 5A		Pack of 1	6BK1136-6AB00-0CU0
F-TM StepDrive ST 1x24..48V 5A		Pack of 1	6BK1136-6SB00-0BU0
TM SITRANS FCT070	D	Pack of 1	7ME4138-6AA00-0BB1
TM SITRANS FST070		Pack of 1	7ME3448-6AA00-0BB1
F-TM Count 1x1Vpp sin/cos HF	H	Pack of 1	6ES7136-6CB00-0CA0
TM ECC 2xPWM ST		Pack of 1	6FE1242-6TM20-0BB1
TM ECC PL ST		Pack of 1	6FE1242-6TM20-0BB1

Ex module	Packing unit	Article number
Ex-DI 4xNAMUR	Pack of 1	6DL1131-6TD00-0HX1
Ex-DQ 2x17.4VDC/27mA	Pack of 1	6DL1132-6CB00-0HX1
Ex-DQ 2x23.1VDC/20mA	Pack of 1	6DL1132-6EB00-0HX1
Ex-AQ 2xI HART	Pack of 1	6DL1135-6TB00-0HX1
Ex-AI 2xI 2-wire HART	Pack of 1	6DL1134-6TB00-0HX1
Ex-AI 4xTC/2xRTD 2-/3-/4-wire	Pack of 1	6DL1134-6JD00-0HX1
Ex-PM E	Pack of 1	6DL1133-6PX00-0HW0

1.8 Encoder modules for Module-to-Module Communication (MtM)

You can use the following modules as encoder modules for Module-to-Module Communication (MtM) with the module DQ 4x24VDC/2A HS in the "Cam control" operating mode:

Module	Article number	Firmware
DI 8x24VDC HS	6ES7131-6BF00-0DA0	V1.0 or higher
DI 8xNAMUR HF	6ES7131-6TF00-0CA0	V2.0 or higher
AI 2xSG 4-,6-Wire HS	7MH4134-6LB00-0DA0	V1.0 or higher
AI 2xUI 2-/4-wire HS	6ES7134-6HB00-0DA1	V1.0 or higher
TM PosInput 1	6ES7138-6BA00-0BA0 6ES7138-6BA01-0BA0	V1.0 or higher V2.0 or higher
TM Count 1x24V	6ES7138-6AA00-0BA0 6ES7138-6AA01-0BA0	V1.0 or higher V2.0 or higher

See also

"Digital output module DQ 4x24VDC/2A HS" Equipment Manual (<https://support.industry.siemens.com/cs/ww/en/view/109475185>)
ET 200SP System Manual (<https://support.industry.siemens.com/cs/ww/en/view/58649293>)

1.9 Motor starters

Motor starters

Direct starter	Packaging unit	Article number
DS 0.1 - 0.4 A HF	Pack of 1	3RK1308-0AA00-0CP0
DS 0.3 - 1 A HF	Pack of 1	3RK1308-0AB00-0CP0
DS 0.9 - 3 A HF	Pack of 1	3RK1308-0AC00-0CP0
DS 2.8 - 9 A HF	Pack of 1	3RK1308-0AD00-0CP0
DS 4.0 - 12 A HF	Pack of 1	3RK1308-0AE00-0CP0

Reversing starter	Packaging unit	Article number
RS 0.1 - 0.4 A HF	Pack of 1	3RK1308-0BA00-0CP0
RS 0.3 - 1 A HF	Pack of 1	3RK1308-0BB00-0CP0
RS 0.9 - 3 A HF	Pack of 1	3RK1308-0BC00-0CP0
RS 2.8 - 9 A HF	Pack of 1	3RK1308-0BD00-0CP0
RS 4.0 - 12 A HF	Pack of 1	3RK1308-0BE00-0CP0

Failsafe direct starter	Packaging unit	Article number
F-DS 0.1 - 0.4 A HF	Pack of 1	3RK1308-0CA00-0CP0
F-DS 0.3 - 1 A HF	Pack of 1	3RK1308-0CB00-0CP0
F-DS 0.9 - 3 A HF	Pack of 1	3RK1308-0CC00-0CP0
F-DS 2.8 - 9 A HF	Pack of 1	3RK1308-0CD00-0CP0
F-DS 4.0 - 12 A HF	Pack of 1	3RK1308-0CE00-0CP0

Fail-safe reversing starter	Packaging unit	Article number
F-RS 0.1 - 0.4 A HF	Pack of 1	3RK1308-ODA00-0CP0
F-RS 0.3 - 1 A HF	Pack of 1	3RK1308-ODB00-0CP0
F-RS 0.9 - 3 A HF	Pack of 1	3RK1308-ODC00-0CP0
F-RS 2.8 - 9 A HF	Pack of 1	3RK1308-ODD00-0CP0
F-RS 4.0 - 12 A HF	Pack of 1	3RK1308-ODE00-0CP0

1.10 Accessories

Accessories

General accessories	Packing unit	Article number
Strain relief units incl. screws	Pack of 5	6ES7193-6RA00-1AN0
Cover for the BusAdapter interface	Pack of 5	6ES7591-3AA00-0AA0
PROFIBUS FastConnect bus connector	Pack of 1	6ES7972-0BB70-0XA0
Female connector, 2x2 pin	Pack of 1	6ES7193-4JB00-0AA0
Server module (spare part)	Pack of 1	6ES7193-6PA00-0AA0
BU cover		
• 15 mm wide	Pack of 5	6ES7133-6CV15-1AM0
• 20 mm wide	Pack of 5	6ES7133-6CV20-1AM0
24 V DC plug (spare part)	Pack of 10	6ES7193-4JB00-0AA0
Shield connector for BaseUnit (shield contacts and shield terminals)	Pack of 5	6ES7193-6SC20-1AM0
Reference identification label, sheet with 16 labels	Pack of 10	6ES7193-6LF30-0AW0
Labeling strips (for labeling the I/O modules)		
• Roll, light gray (with a total of 500 labeling strips)	Pack of 1	6ES7193-6LR10-0AA0
• Roll, yellow (with a total of 500 labeling strips)	Pack of 1	6ES7193-6LR10-0AG0
• DIN A4 sheets, light gray (with a total of 1000 labeling strips)	Pack of 10	6ES7193-6LA10-0AA0
• DIN A4 sheets, yellow (with a total of 1000 labeling strips)	Pack of 10	6ES7193-6LA10-0AG0
Electronic coding element (spare part) ¹⁾		
• Coding element (type A)	Pack of 20	6ES7193-6KA00-3AA0
• Coding element (type B)	Pack of 20	6ES7193-6KB00-3AA0
• Coding element (type C)	Pack of 20	6ES7193-6KC00-3AA0

¹⁾ For the I/O modules, mechanical or electronic coding elements are supplied ex works, depending on the module. Variants A, B, C, D, F and H are available as spare parts. The appropriate coding element can be found in the technical specifications of the respective I/O module. The procedure for changing the coding element is described in the section Changing the type of an I/O module.





²⁾ You may shorten the length of the standard mounting rails and SIMATIC system rails as needed.















1.10 Accessories

General accessories	Packing unit	Article number
• Coding element (type D)	Pack of 20	6ES7193-6KD00-3AA0
Electronic coding element (spare part) ¹⁾		
• Coding element (type F, for fail-safe modules)	Pack of 1	6ES7193-6EF00-1AA0
• Coding element (type H)	Pack of 1	6ES7193-6EH00-1AA0
Mounting rails, tin-plated steel strip ²⁾		
• Length: 483 mm	Pack of 1	6ES5710-8MA11
• Length: 530 mm	Pack of 1	6ES5710-8MA21
• Length: 830 mm	Pack of 1	6ES5710-8MA31
• Length: 2000 mm	Pack of 1	6ES5710-8MA41
SIMATIC system rails ²⁾		
• Length 483 mm	Pack of 1	6ES7193-6MR00-0AA0
• Length 530 mm	Pack of 1	6ES7193-6MR00-0BA0
• Length 830 mm	Pack of 1	6ES7193-6MR00-0CA0
• Length: 2000 mm	Pack of 1	6ES7193-6MR00-0DA0









1) For the I/O modules, mechanical or electronic coding elements are supplied ex works, depending on the module. Variants A, B, C, D, F and H are available as spare parts. The appropriate coding element can be found in the technical specifications of the respective I/O module. The procedure for changing the coding element is described in the section Changing the type of an I/O module.

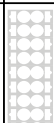

2) You may shorten the length of the standard mounting rails and SIMATIC system rails as needed.

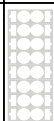
Accessories, color identification labels (push-in terminals), 15 mm wide	Packing unit	Article number
16 process terminals (you can find additional information in the I/O Module manual)		
• Gray (terminals 1 to 16); color code CC00	Pack of 10	 6ES7193-6CP00-2MA0
• Gray (terminals 1 to 8), red (terminals 9 to 16); color code CC01	Pack of 10	 6ES7193-6CP01-2MA0
• Gray (terminals 1 to 8), blue (terminals 9 to 16); color code CC02	Pack of 10	 6ES7193-6CP02-2MA0
• Gray (terminals 1 to 8), red (terminals 9 to 12), gray (terminals 13 to 16); color code CC03	Pack of 10	 6ES7193-6CP03-2MA0
• Gray (terminals 1 to 8), red (terminals 9 to 12), blue (terminals 13 to 16); color code CC04	Pack of 10	 6ES7193-6CP04-2MA0

Accessories, color identification labels (push-in terminals), 15 mm wide	Packing unit	Article number
<ul style="list-style-type: none"> Gray (terminals 1 to 12), red (terminals 13 and 14), blue (terminals 15 and 16); color code CC05 	Pack of 10	 6ES7193-6CP05-2MA0
10 AUX terminals (for BU15-P16+A10+2D, BU15-P16+A10+2B)		
<ul style="list-style-type: none"> Yellow-green (terminals 1A to 10A); color code CC71 	Pack of 10	 6ES7193-6CP71-2AA0
<ul style="list-style-type: none"> Red (terminals 1A to 10A); color code CC72 	Pack of 10	 6ES7193-6CP72-2AA0
<ul style="list-style-type: none"> Blue (terminals 1A to 10A); color code CC73 	Pack of 10	 6ES7193-6CP73-2AA0
10 add-on terminals (for BU15-P16+A0+12D/T, BU15-P16+A0+12B/T)		
<ul style="list-style-type: none"> Red (terminals 1B to 5B), blue (terminals 1 to 5C); color code CC74 	Pack of 10	 6ES7193-6CP74-2AA0
Accessories, color identification labels (push-in terminals), 20 mm wide	Packing unit	Article number
12 process terminals (you can find additional information in the I/O Module manual)		
<ul style="list-style-type: none"> Gray (terminals 1 to 4), red (terminals 5 to 8), blue (terminals 9 to 12); color code CC41 	Pack of 10	 6ES7193-6CP41-2MB0
<ul style="list-style-type: none"> Gray (terminals 1 to 8), red (terminals 9 and 10), blue (terminals 11 and 12), color code CC42 	Pack of 10	 6ES7193-6CP42-2MB0
6 process terminals (you can find additional information in the I/O Module manual)		
<ul style="list-style-type: none"> Gray (terminals 1 to 4), red (terminal 5), blue (terminal 6); color code CC51 	Pack of 10	 6ES7193-6CP51-2MC0
<ul style="list-style-type: none"> Gray (terminals 1, 2 and 5), red (terminals 3 and 4), blue (terminal 6); color code CC52 	Pack of 10	 6ES7193-6CP52-2MC0
4 AUX terminals (for BU20-P12+A4+0B)		
<ul style="list-style-type: none"> Yellow-green (terminals 1A to 4A); color code CC81 	Pack of 10	 6ES7193-6CP81-2AB0
<ul style="list-style-type: none"> Red (terminals 1A to 4A); color code CC82 	Pack of 10	 6ES7193-6CP82-2AB0
<ul style="list-style-type: none"> Blue (terminals 1A to 4A); color code CC83 	Pack of 10	 6ES7193-6CP83-2AB0
2 AUX terminals (for BU20-P6+A2+4D, BU20-P6+A2+4B)		
<ul style="list-style-type: none"> Yellow-green (terminals 1A and 2A); color code CC84 	Pack of 10	 6ES7193-6CP84-2AC0
<ul style="list-style-type: none"> Red (terminals 1A and 2A); color code CC85 	Pack of 10	 6ES7193-6CP85-2AC0
<ul style="list-style-type: none"> Blue (terminals 1A and 2A); color code CC86 	Pack of 10	 6ES7193-6CP86-2AC0

1.10 Accessories

Accessories, color identification labels (push-in terminals) PotDis	Packing unit		Article number
PotDis-BU, 16 potential terminals			
<ul style="list-style-type: none"> Red for PotDis-BU-P1/x-R (terminals 1 to 16); color code CC62 	Pack of 10		6ES7193-6CP62-2MA0
<ul style="list-style-type: none"> Blue for PotDis-BU-P2/x-B (terminals 1 to 16), color code CC63 	Pack of 10		6ES7193-6CP63-2MA0
PotDis-TB-P1-R, 18 potential terminals			
<ul style="list-style-type: none"> Red (terminals 1 to 18); color code CC12 	Pack of 10		6ES7193-6CP12-2MT0
<ul style="list-style-type: none"> Gray (terminals 1 to 18); color code CC10 	Pack of 10		6ES7193-6CP10-2MT0
PotDis-TB-P2-B, 18 potential terminals			
<ul style="list-style-type: none"> Blue (terminals 1 to 18); color code CC13 	Pack of 10		6ES7193-6CP13-2MT0
<ul style="list-style-type: none"> Gray (terminals 1 to 18); color code CC10 	Pack of 10		6ES7193-6CP10-2MT0
PotDis-TB-BR-W, 18 potential terminals			
<ul style="list-style-type: none"> Yellow/green (terminals 1 to 18); color code CC11 	Pack of 10		6ES7193-6CP11-2MT0
<ul style="list-style-type: none"> Red (terminals 1 to 18); color code CC12 	Pack of 10		6ES7193-6CP12-2MT0
<ul style="list-style-type: none"> Blue (terminals 1 to 18); color code CC13 	Pack of 10		6ES7193-6CP13-2MT0

Accessories, color identification labels (push-in terminals) PotDis	Packing unit		Article number
<ul style="list-style-type: none"> Gray (terminals 1 to 18); color code CC10 	Pack of 10		6ES7193-6CP10-2MT0
PotDis-TB-n.c.-G, 18 potential terminals			
<ul style="list-style-type: none"> Gray (terminals 1 to 18); color code CC10 	Pack of 10		6ES7193-6CP10-2MT0

Accessories for motor starter	Packing unit	Article number
3DI / LC module	Pack of 1	3RK1908-1AA00-0BP0
Fan	Pack of 1	3RW4928-8VB00
Additional mechanical bracket for BaseUnit	Pack of 1	3RK1908-1EA00-1BP0
Cover for an empty BaseUnit	Pack of 1	3RK1908-1CA00-0BP0
Touch protection cover for infeed bus	Pack of 1	3RK1908-1DA00-2BP0

Technical specifications for BU cover

Article number	6ES7133-6CV20-1AM0
General information	
Product type designation	BU cover
Ambient conditions	
Ambient temperature during operation	
<ul style="list-style-type: none"> horizontal installation, min. 	-40 °C
<ul style="list-style-type: none"> horizontal installation, max. 	60 °C
<ul style="list-style-type: none"> vertical installation, min. 	-40 °C
<ul style="list-style-type: none"> vertical installation, max. 	50 °C
Altitude during operation relating to sea level	
<ul style="list-style-type: none"> Installation altitude above sea level, max. 	5 000 m; Restrictions for installation altitudes > 2 000 m, see manual
Dimensions	
Width	20 mm
Height	73 mm
Depth	35.3 mm
Article number	6ES7133-6CV15-1AM0
General information	
Product type designation	BU cover

1.10 Accessories

Article number	6ES7133-6CV15-1AM0
Ambient conditions	
Ambient temperature during operation	
<ul style="list-style-type: none"> horizontal installation, min. 	-40 °C
<ul style="list-style-type: none"> horizontal installation, max. 	60 °C
<ul style="list-style-type: none"> vertical installation, min. 	-40 °C
<ul style="list-style-type: none"> vertical installation, max. 	50 °C
Altitude during operation relating to sea level	
<ul style="list-style-type: none"> Installation altitude above sea level, max. 	5 000 m; Restrictions for installation altitudes > 2 000 m, see manual
Dimensions	
Width	15 mm
Height	73 mm
Depth	35.3 mm

Supplements to ET 200SP documentation

2.1 System Manual

System Manual ET 200SP, Edition 11/2023

Section 9.6 Value status

As possible cause for value status = 0, "with activated PROFlenergy break" is listed. If you set the "Continue working" mode, the value status remains = 1.

Chapter 16.9 Mechanical and climatic ambient conditions (Supplement for ET 200SP with CPU)

The mechanical ambient conditions are specified in the following table as sinusoidal oscillations.

Table 2-1 Mechanical environmental conditions for ET 200SP with CPU (from article number 6ES7xxx-xxx03-0AB0)

Frequency range	ET 200SP with CPU and BusAdapter BA 2×FC, BA 2×SCRJ, BA SCRJ/FC, BA 2×LC, BA LC/FC, BA 2×M12	ET 200SP with CPU and BusAdapter BA 2×RJ45, BA SCRJ/RJ45, BA LC/RJ45, BA 2×FC, BA 2×SCRJ, BA SCRJ/FC, BA 2×LC, BA LC/FC, BA 2×M12	ET 200SP with CPU and digital output module F-RQ 1×24VDC/24..230VAC- /5A
$5 \leq f \leq 8.4 \text{ Hz}$	3.5 mm amplitude		
$8.4 \leq f \leq 150 \text{ Hz}$	1 g constant acceleration		
$10 \leq f \leq 60 \text{ Hz}$	0.35 mm amplitude	---	---
$60 \leq f \leq 1000 \text{ Hz}$	5 g constant acceleration ¹⁾		

¹⁾ Without using an RJ45 connector on the integrated PROFINET IO interface (RJ45 port) X1 Port 3 or X2 Port 1; the strain relief (6ES7193-6RA00-1AN0) must be mounted (for more information, refer to the ET 200SP BusAdapter Equipment Manual).

2.2 BaseUnits manual

2.2.1 Special consideration for BaseUnits with functional versions < 04

The following BaseUnits with functional version < 04 can only be used in potential groups with rated voltages ≤ 48 V DC or 24 V AC:

- BaseUnit BU20-P12+A0+4B (6ES7193-6BP20-0BB1).
- BaseUnit BU20-P12+A0+0B (6ES7193-6BP00-0BD0).

2.3 BusAdapter Equipment Manual

Strain relief

The strain relief 6ES7193-6RA00-1AN0 with FS01 is not suitable for the optical PROFINET cables of the BusAdapters.

BusAdapter BA 2xFC

A further cable has been added to the recommended types of Fast Connect Cable: IE FC TP Marine Cable (6XV1840-4AH10)

2.4 Interface module manuals

Compilation error up to STEP 7 V15.1 for IM 155-6 PN HF as of V2.1, IM 155-6 PN HS V4.0

Affected components:

- IM 155-6 PN HF as of V2.1
- IM 155-6 PN HS V4.0

A compilation error can occur in isochronous mode of the ET 200SP (IM 155-6 PN HF as of V2.1, IM 155-6 PN HS V4.0) with the setting "From OB" even if the settings are valid. The typical error message is: "The specific Ti value is invalid" or "The specific To value is invalid". But other error messages are possible as well.

Solution:

Upgrade the module description of the IM in this case. You can upgrade the module description of the IM in the network view or in the device view of the Inspector window using the "Update module description" function. The error can still occur with the current module description after the first compilation. If you have selected valid settings, the error will no longer occur with the subsequent compilation.

Equipment Manual IM 155-6 PN BA, Edition 03/2015

Status of the supply voltage

Load voltage diagnostics are only valid if the station started up with a valid and complete configuration.

- For modules in the following table without a parameter assignment, the status of the supply voltage is always signaled as "1" regardless of the actual status of the supply voltage.
- If a potential group is exclusively made up of modules without parameter assignment from the table below, no group diagnostics "Missing supply voltage L+" is signaled for this potential group.

Modules	Order number
DI 8x24VDC ST	6ES7131-6BF00-0BA0
DI 16x24VDC ST	6ES7131-6BH00-0BA0
DI 8x24VDC HF	6ES7131-6BF00-0CA0
DQ 4x24VDC/2A ST	6ES7132-6BD20-0BA0
DQ 8x24VDC/0,5A ST	6ES7132-6BF00-0BA0
DQ 16x24VDC/0,5A ST	6ES7132-6BH00-0BA0
DQ 8x24VDC/0,5A HF	6ES7132-6BF00-0CA0

Equipment Manual IM 155-6 PN ST, Edition 04/2017**Response times**

The response time of the IM 155-6 PN ST is made up of:

- Backplane bus cycle time
- Operating system processing

NOTE**Validity of the formula**

The following formula applies to the ET 200SP backplane bus.

The formula does not apply to the ET-Connection bus.

Backplane bus cycle time

The backplane bus cycle time is the time the interface module requires to output new output data, read new input data and then copy the data to the PROFINET send buffer.

The backplane bus cycle time is the result of the update time configured for the interface module as IO device and amounts to at least 1 ms.

- If the configured update time ≥ 1 ms, the backplane bus cycle time is equal to the configured update time.
- If the configured update time < 1 ms, the backplane bus cycle time is the product of an integer multiple of the configured update time.

Table 2-2 Example calculation

Configured update time	Backplane bus cycle time (integer multiple, minimum 1 ms)
250 μ s	4 x 250 μ s = 1000 μ s
750 μ s	2 x 750 μ s = 1500 μ s
1000 μ s	1000 μ s
2000 μ s	2000 μ s

Operating system processing time

The operating system processing time is calculated based on the following formula:

Operating system processing time output

Operating system processing time_output[μ s] = 147 + 3.775 number_m + 0.275 bytes_out

Operating system processing time input

Operating system processing time_input[μ s] = 158.3 + 2.325 number_m + 0.325 bytes_in

Explanation of the parameters:

Number_m: Total number of all modules (incl. server module)

Bytes_out: Sum of all output bytes

Bytes_in: Sum of all input bytes

Calculating the response time**Response time output**

The response time output of the IM 155-6 PN ST is made up of:

- Backplane bus cycle time
- Operating system processing time_output.

Response time input

The response time input of the IM 155-6 PN ST is made up of:

- Backplane bus cycle time
- Operating system processing time_input.

Equipment Manual IM 155-6 PN ST, Edition 04/2017

You can perform a firmware update to V4.1 for IM 155-6 PN ST interface modules with the article number 6ES7155-6AU00-0BNO.

If you perform hardware detection of the IO device in the TIA Portal as of V15.0 after the firmware update to V4.1, the device name is displayed as not assigned in the "PROFINET device name" column in the "Topology comparison" tab of the interface module.

The reason is that the online combination of article number and firmware version of the IO device is not offered in the hardware catalog.

In this case, the hardware catalog for the interface module IM 155-6 PN ST offers the combination of article number 6ES7155-6AU00-0BNO and FW up to V3.3.

Solution: In the "Topology comparison" tab, assign the device name offered from the selection list in the "PROFINET device name" column.

Equipment Manual IM 155-6 PN ST, Edition 10/2020**Section 2.2 Functions
Requirements**

Table 2-3 Version dependencies of other module functions

Function	Product version of the module as of	Firmware version of the module as of	Configuration software		
			Configuration with GSD file/third-party software ¹	STEP 7 as of V5.5 SP3 with HSP241	STEP 7 (TIA Portal) as of V11 SP2
BusAdapter BA 2xM12	1	V4.2	X	-	X (as of V16 Update 1)

¹ Systems of third-party manufacturers: dependent on the range of functions of the third-party system

BusAdapter BA 2xM12 and firmware V4.1

When using a BusAdapter BA 2xM12 and firmware V4.1, note that an update to version V4.2 via another BusAdapter must be performed first so that the IM can run.

Equipment Manual IM 155-6 PN/2 HF, Edition 10/2018**Section 2.1 Properties****Maximum configuration**

- 64 ET 200SP I/O modules + 16 ET 200AL modules
- 1 m backplane bus (without interface module)

Server module

The server module supports the identification data I&M 0 to 3.

Section 2.2 Functions**Module-to-Module Communication (MtM)**

At a CPU STOP or failure of communication between the interface module and CPU, all modules of the ET 200SP output substitute values.

Equipment Manual IM 155-6 PN/3 HF, Edition 10/2018**Section 2.1 Properties****Maximum configuration**

- 64 ET 200SP I/O modules + 16 ET 200AL modules
- 1 m backplane bus (without interface module)

Section 2.2 Functions

The "Interface-local coupling of IO data" function can also be used in addition to GSDML with STEP 7 (TIA Portal) as of V15.1 with HSP285.

Module-to-Module Communication (MtM)

At a CPU STOP or failure of communication between the interface module and CPU, all modules of the ET 200SP output substitute values.

Table 2-1 Version dependencies of the module functions

The "Interface-local coupling of IO data" function is possible with STEP 7 (TIA Portal) as of V15.1 with HSP285.

Section 3 Wiring

Notes

NOTE

To set up a ring topology, use only the P1 R and P2 R ports.

NOTE

Operation with only one BusAdapter

You can operate the interface module with only one BusAdapter on P1 R and P2 R. Disable the P3 port in the port options in STEP 7 for this. Cover the free BusAdapter port P3 with a BusAdapter interface cover (6ES7591-3AA00-0AA0).

NOTE

For IRT operation, both BusAdapters must be plugged in.

Section 5.3.4 Invalid configuration states of the ET 200SP on PROFINET IO

NOTE

Removal of the server module will trigger a station stop. All I/O modules of the ET 200SP distributed I/O system fail (substitute value behavior) but the interface module continues to exchange data.

The virtual MSO Local modules are not affected by the failure.

Revoking the station stop (by correcting the invalid configuration state) leads to a brief failure of the ET 200SP distributed I/O system and automatic restart.

Section 6 Compatibility

Restoring the factory settings on the interface module via the RESET button

There is a special operation for interface module IM 155-6 PN/3 HF to reset it to the factory settings using the Reset button.

Requirements

The supply voltage to the interface module must be switched on.

Required tool

3 to 3.5 mm screwdriver (for resetting via the RESET button)

Procedure

1. Remove the interface module from the mounting rail and swivel it downwards.
2. The RESET button is located on the back of the interface module behind a small opening: Push a screwdriver into the small opening, thus pressing the RESET button.
3. Release the RESET button.
4. Press the RESET button for another 3 seconds.
5. Look at the LED display of the interface module to see whether the reset was successful: RUN LED flashes for 3 seconds, ERROR and MAINT LED are off.
6. Install the interface module back on the mounting rail.
7. Configure the interface module again.

Equipment Manual IM 155-6 PN HF, Edition 12/2015**Section 3.1 Pin assignment**

PROFINET interface X1 Port 2:

If autonegotiation is disabled, the RJ-45 socket (X1 Port 2) has the switch assignment (MDI-X).

Equipment Manual IM 155-6 PN HS, Edition 09/2016**Section 3.1 Pin assignment**

PROFINET interface X1 Port 2:

If autonegotiation is disabled, the RJ45 socket (X1 Port 2) has the switch assignment (MDI-X).

Section 7 Technical specifications

- The PROFINET certification of network Class 3 is in preparation.
- Technical specifications of the BusAdapters BA 2×SCRJ, BA SCRJ/RJ45, BA SCRJ/FC:
The maximum length of the PCF-GI fiber-optic cable is 250 m.

Equipment Manual IM 155-6 DP HF, Edition 10/2018**Section 2.2.1 Requirements**

Table 2-4 Version dependencies of other module functions

Function	Product version of the module as of	Firmware version of the module as of	Configuration software		
			Configuration with GSD file/third-party software ¹	STEP 7 as of V5.5 SP3 with HSP0242	STEP 7 (TIA Portal) as of V13
Interface module; article number: 6ES7155-6BA01-0CNO	1	V4.2	X	X ²	X (as of V15.1)

¹ Systems of third-party manufacturers: dependent on the range of functions of the third-party system

² Configure the module as version 6ES7155-6BA00-0CNO FW V3.1 (as of HSP0242 V3)

Compatibility with BusAdapter BA 2xM12

The following table shows the compatibility of the BusAdapter BA 2xM12 with the interface modules:

Interface module	BA 2xM12 is supported	Configurable with		
		PROFINET GSD	STEP 7	STEP 7 (TIA Portal)
IM155-6 PN HS (6ES7155-6AU00-0DN0)	No	-	-	-
IM155-6 PN ST (6ES7155-6AU01-0BN0)	Yes, as of FW V4.2	Yes	-	V16 or higher with HSP205
IM155-6 PN HF (6ES7155-6AU00-0CN0)			V5.5.4.0 or higher with HSP0250 V5.0	V16 or higher with HSP302
IM155-6 PN/2 PN HF (6ES7155-6AU01-0CN0)				
IM155-6 PN/3 PN HF (6ES7155-6AU30-0CN0)				
IM155-6 MF HF (6ES7155-6MU00-0CN0)	Yes, as of FW V5.0		V5.5.4.0 or higher with HSP0250 V5.0 configured as IM155-6 PN/2 PN HF V4.2	V16 or higher with HSP302 configured as IM155-6 PN/2 PN HF V4.2

Compatibility with BusAdapter BA 2xLC-LD, BA LC-LD/RJ45 and BA LC-LD/M12

The following table shows the compatibility of the BusAdapter BA 2xLC-LD, BA LC-LD/RJ45 and BA LC-LD/M12 with the interface modules:

Interface module	BA 2xLC-LD	BA LC-LD/RJ45	BA LC-LD/M12	Configurable with		
				PROFINET GSD	STEP 7	STEP 7 (TIA Portal)
IM155-6 PN HS (6ES7155-6AU00-0DN0)	No			-	-	-
IM155-6 PN ST (6ES7155-6AU01-0BN0)						
IM155-6 PN HF (6ES7155-6AU00-0CN0)						
IM155-6 PN/2 PN HF (6ES7155-6AU01-0CN0)	Yes, as of FW V4.2 configured as BA 2xLC and monitor port disabled	Yes, as of FW V4.2 configured as BA LC/RJ45 and monitor port disabled		Yes	V5.5.4.0 or higher with HSP0250 V4 / HSP0255 V5.0	V15.1 or higher
IM155-6 PN/3 PN HF (6ES7155-6AU30-0CN0)						
IM155-6 MF HF (6ES7155-6MU00-0CN0)	Yes, as of FW V5.1 configured as BA 2xLC and monitor port disabled	Yes, as of FW V5.1 configured as BA LC/RJ45 and monitor port disabled; max. cable length 3 km			V5.5.4.0 or higher with HSP0250 V4 / HSP0255 V5.0 configured as IM155-6 PN2-/2 PN HF V4.2	V15.1 or higher, configured as IM155-6 PN/2 PN HF V4.2
IM155-6 R1 (6ES7155-6AU00-0HM0)	Yes				-	V18 or higher

IM 155-6 MF HF FW 5.2

For IM 155-6 MF HF with FW 5.2, the following applies in Function Manual "MultiFieldbus", section 4.2.3.5 "Data record interface":

Record response (big-endian, read-only access)

Register Offset	Block	Field	Size	Description
0x0041		Processed Length	Unsigned16	Processed length of the PROFINET data record in bytes Read: Length of the PROFINET data record read for Request Control == "Execute read" (0x0000 for "Continue read") Write: Record length of the executed write job = Record Length (Zero in case of an error)

Equipment Manual IM 155-6 MF HF, Edition 01/2022**NOTE****Use in STEP 7 or STEP 7 TIA Portal**

To use the interface module in STEP 7 or STEP 7 TIA Portal, install the GSD file. You can find the latest GSD file on the Internet

(<https://support.industry.siemens.com/cs/ww/en/view/57138621>).

After installation, the interface module can be found under "Other field devices".

Data record interface for MF Shared Device

The MF device supports the simultaneous use of the data record interface for max. 2 fieldbuses.

Section 2.2 Functions**Module-to-Module Communication (MtM)**

At a CPU STOP or failure of communication between the interface module and CPU, all modules of the ET 200SP output substitute values.

Section 3.1.11 Configuration control (option handling)

Configuration control is possible, but modules with submodules distributed on different ARs/fieldbuses may not be part of the AR for active configuration control.

Section 7.2.5 Connection hold time

After the hold time has elapsed, the outputs react as described in the section "Substitute value behavior".

Section 7.2.5 Hold time after connection reset

After the hold time has elapsed, the outputs react as described in the section "Substitute value behavior".

Equipment Manual IM 155-6 PN R1, Edition 11/2022**Section 2.1 Properties****Accessories**

BA 2xLC-LD (long distance) for single-mode fiber-optic cable with maximum length of 20 km

2.5 I/O module manuals

Safety-related shutdown of standard modules

You can find the latest information on the standard modules that support safety-related shutdown, up to which SIL and Cat./PL and wiring examples, in this FAQ (<https://support.industry.siemens.com/cs/ww/en/view/39198632>) and in the online version of the technical specifications.

Configuration notes on the I/O modules (supplement to Product overview section in the manual)

I/O module		Article number	Firmware version	STEP 7 (TIA Portal)	STEP 7 V5.5 SP3
Digital input modules	DI 16x24VDC ST	6ES7131-6BH00-0BA0	V1.1.0	HSP0162 V13 SP1 or higher	HSP0229 V6.0
	DI 8x24VDC BA	6ES7131-6BF00-0AA0	V1.0.0	HSP0126	HSP0229 V5.0
	DI 8x24VDC ST	6ES7131-6BF00-0BA0	V1.1.0	V13 Update 3	HSP0229 V4.0
	DI 8x24VDC HF	6ES7131-6BF00-0CA0	V2.0.0	HSP0163 V13 SP1 Update 4 or higher	HSP0229 V6.0
	DI 8x24VDC HS	6ES7131-6BF00-0DA0	V1.0.2	Integrated as of V14	HSP0229 V5.0
Digital output modules	DQ 8x24VDC/0.5A BA	6ES7132-6BF00-0AA1	V1.0.0	HSP0162 V13 SP1 or higher	HSP0230 V6.0
	DQ 4x24VDC/2A ST	6ES7132-6BD20-0BA0	V1.1.0	V13 Update 3	HSP0230 V4.0
	DQ 8x24VDC/0.5A ST	6ES7132-6BF00-0BA0	V1.1.0	V13 Update 3	HSP0230 V4.0
	DQ 16x24VDC/0.5A ST	6ES7132-6BH00-0BA0	V1.1.0	HSP0162 V13 SP1 or higher	HSP0230 V6.0
	DQ 8x24VDC/0.5A HF	6ES7132-6BF00-0CA0	V2.0.0	HSP0163 V13 SP1 Update 4 or higher	HSP0230 V6.0
	DQ 4x24VDC/2A HF	6ES7132-6BD20-0CA0	V2.0.0	HSP0163 V13 SP1 Update 4 or higher	HSP0230 V6.0
	DQ 4x24VDC/2A HS	6ES7132-6BD20-0DA0	V1.0.2	Integrated as of V14	HSP0230 V5.0
	DQ 4x24...230VAC/2A ST	6ES7132-6FD00-0BB1	V1.0	as of V13	HSP0230 V3.0
	DQ 4x24...230VAC/2A HF	6ES7132-6FD00-0CU0	V1.0.0	as of V14 with HSP0240	HSP 0230 as of V8.0
	RQ 4x120VDC-230VAC/-5A NO ST	6ES7132-6HD00-0BB1	V1.0.0	HSP0128	HSP0232 V5.0

I/O module		Article number	Firmware version	STEP 7 (TIA Portal)	STEP 7 V5.5 SP3
Digital output modules	RQ 4x120VDC-230VAC/-5A NO MA ST	6ES7132-6MD00-0BB1	V1.0.0	HSP0162 V13 SP1 or higher	HSP0232 V6.0
Analog input modules	AI 8xU BA	6ES7134-6FF00-0AA1	V1.0.0	HSP0126	HSP0227 V5.0
	AI 2xU ST	6ES7134-6FB00-0BA1	V1.0.0	HSP0160 V13 SP1 or higher	HSP0227 V6.0
	AI 8xI 2-/4-wire BA	6ES7134-6GF00AA1	V1.0.0	HSP0126	HSP0227 V5.0
	AI 4xI 2-/4-wire ST	6ES7134-6GD00-0BA1	V1.1.0	V13 Update 3	HSP0227 V4.0
	AI 2xI 2-/4-wire ST	6ES7134-6GB00-0BA1	V1.0.0	HSP0160 V13 SP1 or higher	HSP0227 V6.0
	AI 4xU/I 2-wire ST	6ES7134-6HD00-0BA1	V1.1.0	V13 Update 3	HSP0227 V4.0
	AI 2xU/I 2-/4-wire HF	6ES7134-6HB00-0CA1	V2.0.0	HSP0161 V13 SP1 or higher	HSP0227 V6.0 V5.5 SP4 HF7 or higher
	AI 2xU/I 2-/4-wire HS	6ES7134-6HB00-0DA1	V2.0.1	Integrated as of V14	HSP0227 V5.0
	AI Energy Meter 400VAC ST	6ES7134-6PA01-0BD0	V3.0.0	V13 SP1 Update 4 HSP0159	HSP0227 V6.0
	AI Energy Meter 480VAC ST	6ES7134-6PA20-0BD0	V4.0.0	V13 SP1 Update 4 HSP0159	HSP0227 V6.0 V5.5 SP4 HF7 or higher
	AI Energy Meter 480VAC/CT HF	6ES7134-6PA00-0CU0	V6.0.0	V15 or higher with HSP0253	V5.5 SP3 or higher
AI Energy Meter 480VAC/RC HF	6ES7134-6PA20-0CU0	V6.0.0	V15 or higher with HSP0253	V5.5 SP3 or higher	
Analog output modules	AQ 2xU ST	6ES7135-6FB00-0BA1	V1.0.0	HSP0160 V13 SP1 or higher	HSP0228 V6.0
	AQ 2xI ST	6ES7135-6GB00-0BA1	V1.0.0	HSP0160 V13 SP1 or higher	HSP0228 V6.0
	AQ 4xU/I ST	6ES7135-6HD00-0BA1	V1.1.0	V13 Update 3	HSP0228 V4.0
	AQ 2xU/I HS	6ES7135-6HB00-0DA1	V2.0.1	Integrated as of V14	HSP0228 V5.0

2.5.1 Digital module device manuals

I/O modules Equipment Manuals

LED DIAG

Table 2-5 LED DIAG fault display

LED DIAG	Meaning
□ Off	Backplane bus supply of the system is interrupted or switched off.
⚡ Flashes	Module parameters not assigned
■ On	Module parameters assigned and no module/channel diagnostics
⚡ Flashes	Module parameters assigned and module/channel diagnostics

Equipment Manuals for I/O modules ST, BA

When you have disabled all channels of the I/O module, a diagnostic message is still generated in the case of a fault if the "No supply voltage L+" diagnostics is enabled. For the following I/O modules, this behavior is corrected as of firmware version > V1.1.0:

- DI 16x24VDC ST
- DI 8x24VDC ST
- DQ 16x24VDC/0.5A ST
- DQ 8x24VDC/0.5 A ST
- DQ 4x24VDC/0.5A ST

Equipment Manuals for digital input modules with wire-break check

When wire-break check is configured the module requires a low quiescent current at the digital input in case of "0" signal for the monitoring. The parallel connection of a resistor with 25 kΩ to 45 kΩ is required in order that this quiescent current can flow when encoder contacts are open.

If wire-break check is disabled in the configuration, no parallel connection of the resistor is required.

If wire-break check is configured, connect a resistor with 25 kΩ to 45 kΩ parallel to each mechanical encoder contact.

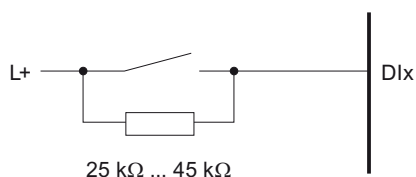

Figure 2-1 Connect mechanical encoder contact with resistor

Equipment Manual DI 8x24VDC HF, Edition 02/2014**Section 6.1 Technical specifications**

- 24 V encoder supply
 - Output current, max.: 700 mA, total current

Equipment Manual DI 8xNAMUR HF, Edition 02/2014**Section A.2 Parameter assignment and structure of parameter data record**

With data records 0 to 7, you can configure individual channels.

When the interface module IM 155-6 DP HF (PROFIBUS DP) is used and data records 0 and 1 are read, the module returns the diagnostics data records and not the parameter data records of the DI 8xNAMUR HF.

DQ Modules Equipment Manuals

Equipment Manual	Edition
DQ 8x24VDC/0.5A BA (6ES7132-6BF01-0AA0)	02/2019
DQ 8x24VDC/0.5A HF (6ES7132-6BF00-0CA0)	12/2017
DQ 8x24VDC/0.5A ST (6ES7132-6BF01-0BA0)	02/2019
DQ 8x24VDC/0.5A SNK BA (6ES7132-6BF61-0AA0)	02/2019

NOTICE**Current load of combined return conductors**

When connecting in 2-wire connection, the static current load of the combined return conductor must not exceed 2A per terminal.

Equipment Manual DQ 4x24VDC/2A ST, Edition 12/2015**Section 3.1 Wiring and block diagram**

The following figure shows an example of the terminal assignment of the digital output module DQ 4x24VDC/2A ST on the BaseUnit BU type A0 without AUX terminals (1- and 2-wire connection).

NOTICE**Current load of combined return conductors**

When connecting in 2-wire connection, the static current load of the combined return conductor must not exceed 2A per terminal.

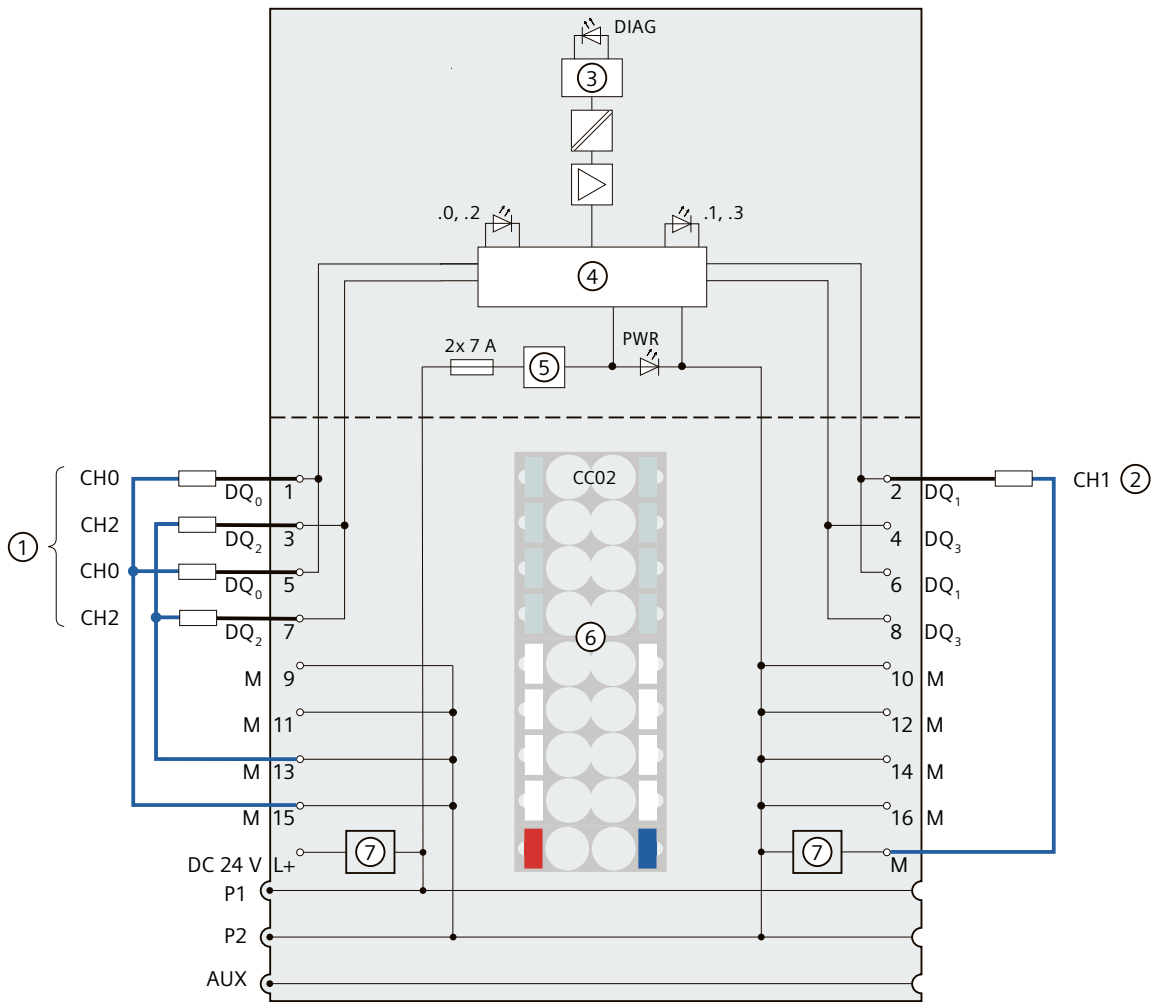

①	2-wire connection	DQ _n	Output signal, channel n
②	1-wire connection	24 V DC	Supply voltage L+ (infeed for light-colored BaseUnit only)
③	Backplane bus interface	M	Ground
④	Output electronics	P1, P2, AUX	Internal self-assembling voltage buses Connection to the left (dark-colored BaseUnit) Connection to the left interrupted (light-colored BaseUnit)
⑤	Polarity reversal protection	DIAG	Error or diagnostics LED (green, red)
⑥	Color-coded label with color code CC02 (optional)	0.0 to 0.3	Channel status LED (green)
⑦	Filter connection supply voltage (only when light-colored BaseUnit is present)	PWR	Power LED (green)

Figure 2-2 Block diagram and terminal assignment for 1- and 2-wire connection of actuators

Equipment Manual DQ 4x24VDC/2A HF, Edition 12/2015

Section 3.1 Wiring and block diagram

The following figure shows an example of the terminal assignment of the digital output module DQ 4x24VDC/2A HF on the BaseUnit BU type A0 without AUX terminals (1- and 2-wire connection).

NOTICE

Current load of combined return conductors

When connecting in 2-wire connection, the static current load of the combined return conductor must not exceed 2A per terminal.

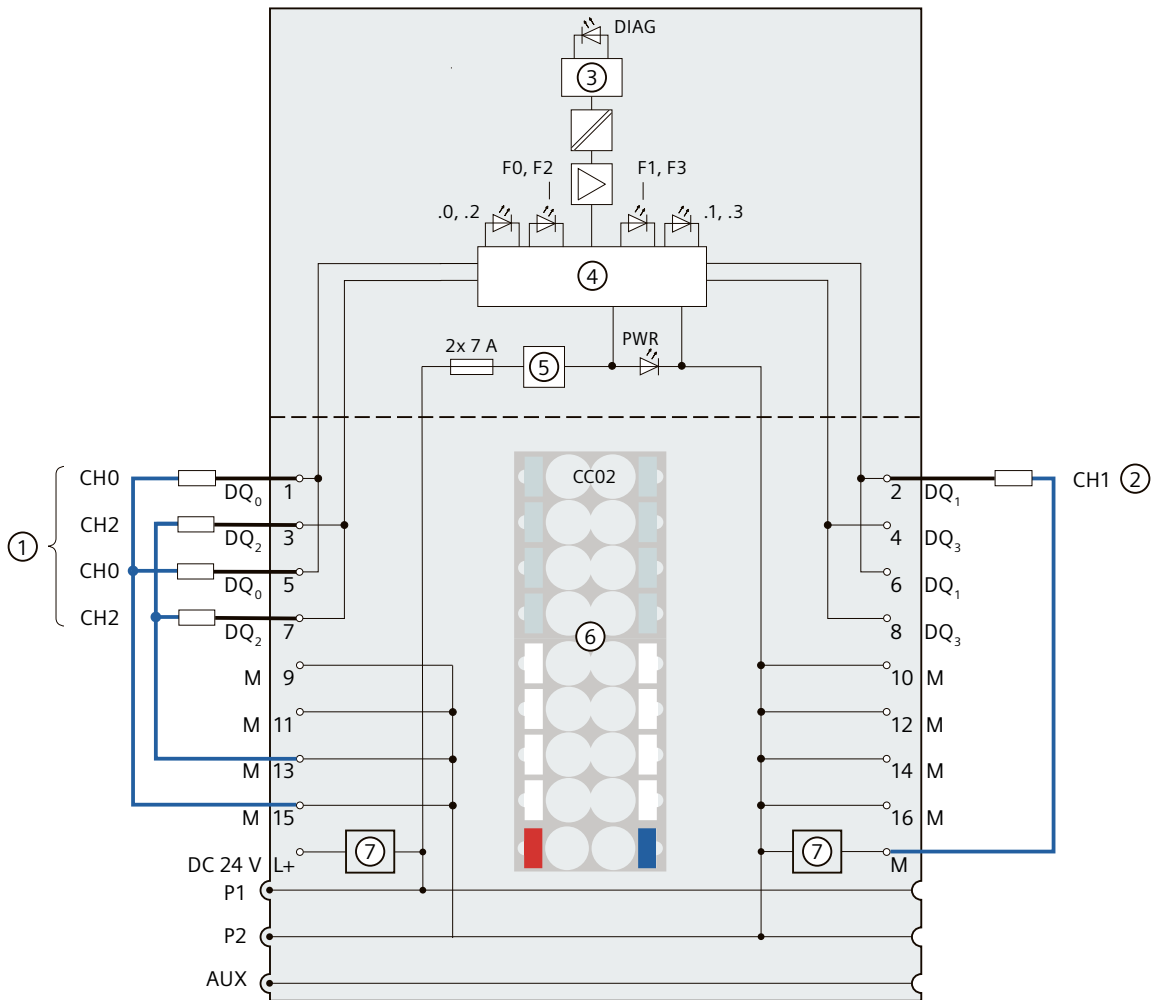

- | | | | |
|---|-------------------------|-------------|---|
| ① | 2-wire connection | 24 V DC | Supply voltage L+ (infeed for light-colored BaseUnit only) |
| ② | 1-wire connection | M | Ground |
| ③ | Backplane bus interface | P1, P2, AUX | Internal self-assembling voltage buses
Connection to the left (dark-colored BaseUnit)
Connection to the left interrupted (light-colored BaseUnit) |

2.5 I/O module manuals

④	Output electronics	DIAG	Error or diagnostics LED (green, red)
⑤	Polarity reversal protection	0.0 to 0.3	Channel status LED (green)
⑥	Color-coded label with color code CC02 (optional)	F0 to F3	Channel fault LED (red)
⑦	Filter connection supply voltage (only when light-colored BaseUnit is present)	PWR	Power LED (green)
DQ _n	Output signal, channel n		

Figure 2-3 Block diagram and terminal assignment for 1- and 2-wire connection of actuators

Equipment Manual DQ 4x24VDC/2A HS, Edition 09/2016

Section 6.1 Technical specifications

For this module, the marine approval for the bridge and deck zone is valid from a bus cycle time of at least 250 μ s.

DQ 4x24VDC/2A HS Equipment Manual, Edition 05/2021

Section 6.4.1.3 Address space

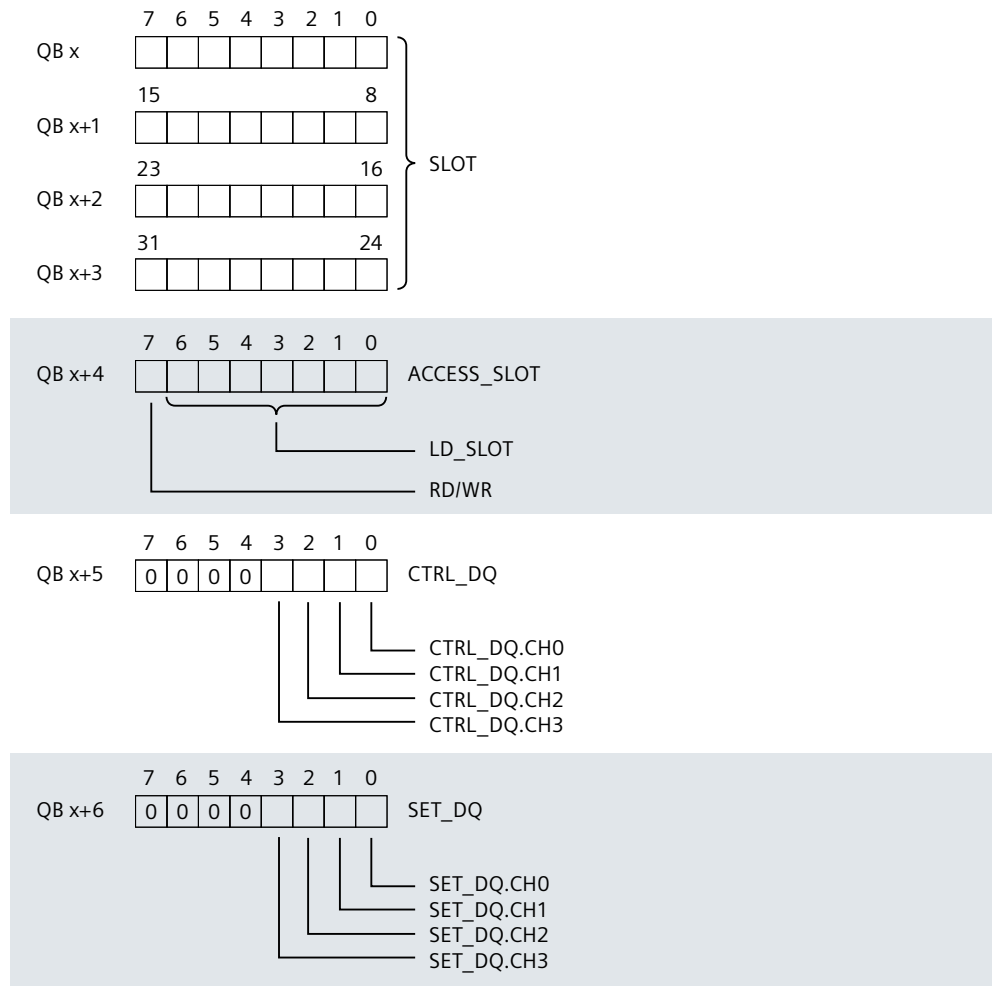
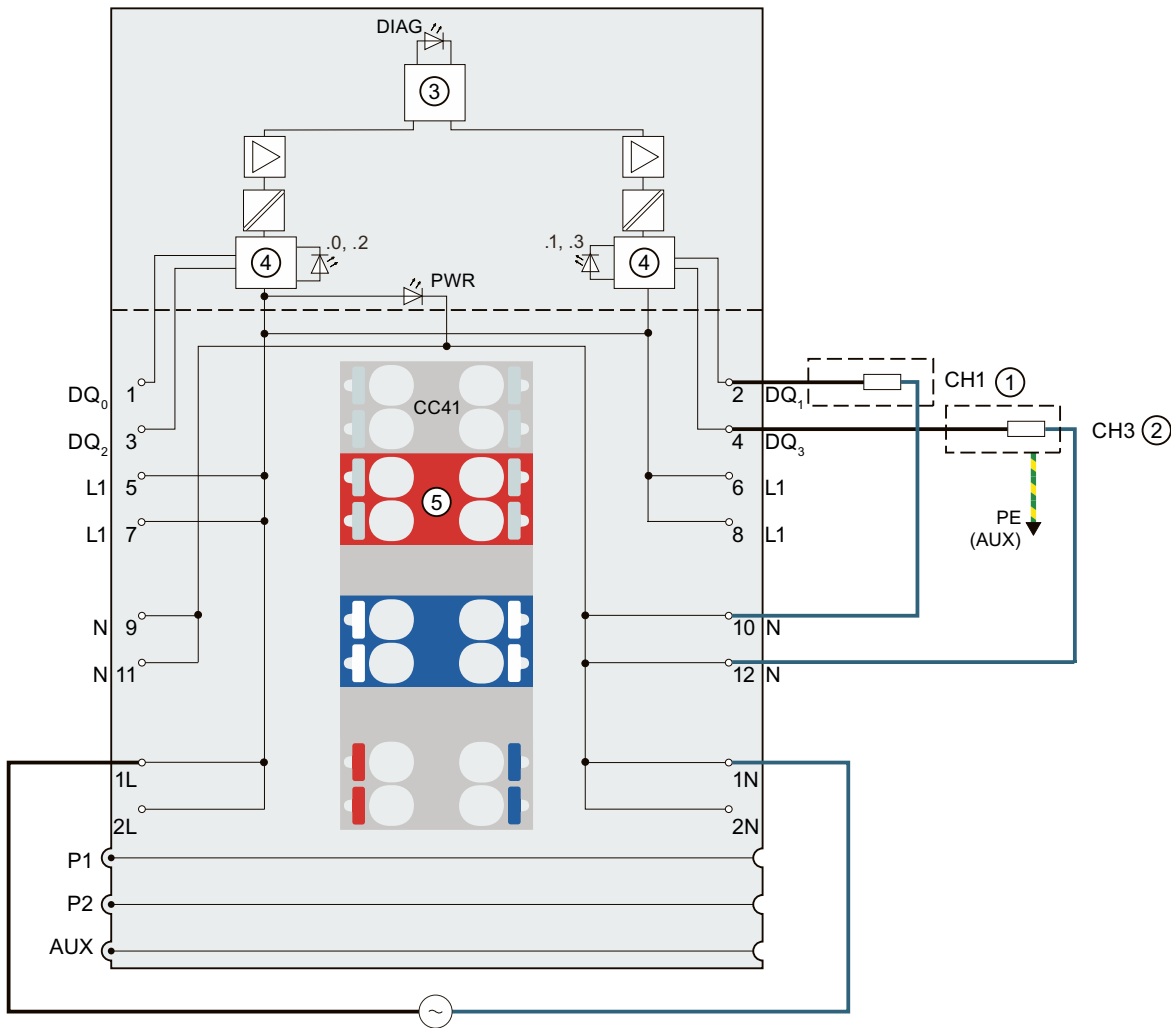

Figure 2-4 Assignment of the control interface

Equipment Manual Digital Output Module DQ 4x24..230VAC/2A ST, Edition 03/2015

Section 3.1 Wiring and block diagram

The following figure shows the block diagram and an example of the pin assignment of the digital output module DQ 4x24..230VAC/2A ST on the BaseUnit BU type B1.



- | | | | |
|---|-----------------------------------|----------|------------------------------------|
| ① | 2-wire connection | N | Neutral conductor |
| ② | 3-wire connection | 1L, 2L | Supply voltage 24 V AC to 230 V AC |
| ③ | Backplane bus interface | 1N, 2N | Neutral conductor supply voltage |
| ④ | Output electronics | PE (AUX) | Protective conductor connection |
| ⑤ | Color-coded label CCxx (optional) | DIAG | Diagnostics LED (red/green) |

DQ _n	Output signal, channel n	.0, .1, .2, .3	Channel status LED (green)
L1	Encoder supply	PWR	Power LED (green)
P1, P2, AUX	Internal self-assembling voltage buses Connection to left (dark-colored BaseUnit)		

Figure 2-5 Wiring and block diagram for 2-wire and 3-wire connection of actuators

Section 3.1 Pin assignment; Supply voltage fuse protection

The module has neither short-circuit protection nor overload protection. Protect the module from being destroyed by impermissible high current and install a fine fuse in the supply line. The maximum rated current of the fine fuse depends on the hardware function status (FS) of the module.

HW functional status of the module	Max. rated current of fuse	Tripping characteristic
FS ≤ 3	8 A	Quick response
FS ≥ 4	10 A	Quick response

Section 6.1 Technical specifications, Switching frequency with inductive load

The switching frequency of the outputs with inductive loads is max. 0.5 Hz.

Higher switching frequency is possible in spite of this, and depends on the alternating voltage and switched inductors or the power factor of the electric motor used.

Alternating voltage	Condition	Max. switching frequency
200 VAC or lower	---	10 Hz
200 VAC or higher	<ul style="list-style-type: none"> Power factor of the electric motor $\cos \varphi > 0.35$ Electric motor must only be turned off after start-up (no jogging mode). Electric motors which are turned off during start-up could create inductive shutoff voltages > 600 V, which could destroy the output electronics (Triac). 	10 Hz

Section 6.1 Technical specifications

Supply voltage

Rated value (AC)	24 V to 230 V
------------------	---------------

Equipment Manual DQ 4x24..230VAC/2A HF, Edition 02/2018

Section 3.1.1. and 4.1.1 Wiring and block diagram

The following figure shows an example of the pin assignment of the digital output module DQ 4x24..230VAC/2A HF on BaseUnit BU type U0 (3-wire connection) in combination with a potential distribution module and terminal block.

For a 3-wire connection you connect the protective earth (PE) of the actuator to the terminal block.

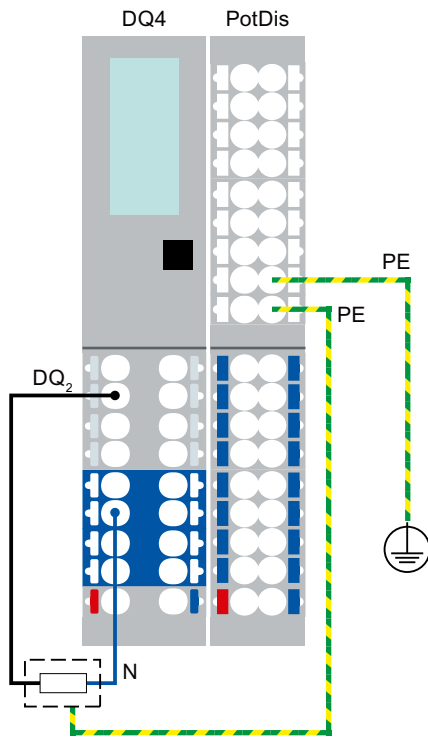
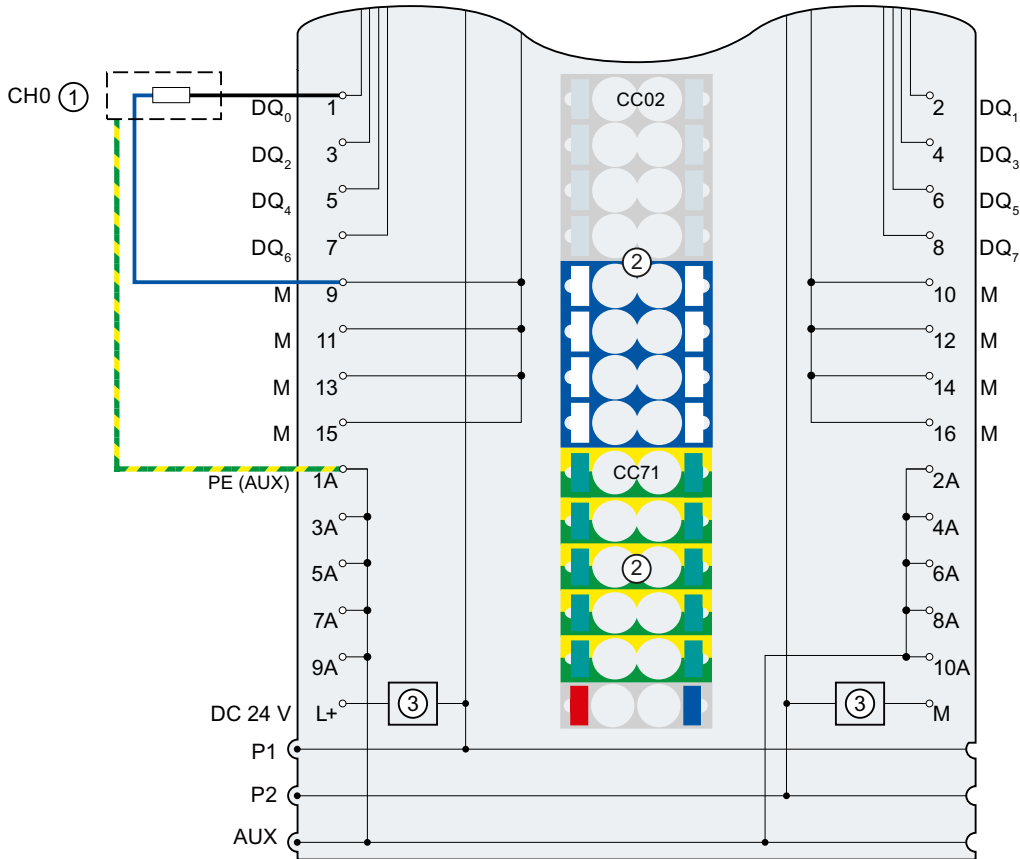

Figure 2-6 3-wire connection of actuators with potential distribution module at the digital output module DQ 4x24..230VAC/2A HF

Equipment Manual Digital Output Module DQ 8x24VDC/0.5A ST, Edition 02/2019

Connection: 3-wire connection of actuators

The following figure shows an example of the pin assignment of the digital output module DQ 8x24VDC/0.5A ST on the BaseUnit BU type A0 with AUX terminals (3-wire connection).



①	3-wire connection	1 A ... 10 A	AUX terminals
②	Color-coded labels with color codes CC02 and CC71 (optional)	PE (AUX)	Protective conductor connection
③	Filter connection supply voltage (only when light-colored BaseUnit is present)	24 V DC	Supply voltage L+ (infeed for light-colored BaseUnit only)
DQ _n	Output signal, channel n	M	Ground
		P1, P2, AUX	Internal self-assembling voltage buses Connection to left (dark-colored BaseUnit) Connection to left interrupted (light-colored BaseUnit)

Figure 2-7 Terminal assignment for 3-wire connection of actuators

**Equipment Manuals RQ 4x120VDC-230VAC/5A NO MA ST; Edition 06/2020,
RQ 4x120VDC-230VAC/5A NO ST, Edition 06/2020**

Section 3.1 Wiring and block diagram

NOTICE

The relay channels have no integrated short-circuit protection. Provide external short-circuit protection in the form of a miniature fuse with a maximum tripping current of 6.3 A and a fast tripping characteristic. A breaking capacity of at least 1500 A is required for mains voltages. For all other applications and for supply networks with a short-circuit current greater than 1500 A, you need to use a miniature fuse with an appropriately adapted breaking capacity.

 WARNING

Do not connect exposed extra-low-voltage (SELV/PELV) and dangerous live voltages between channels at the same time!

If you only use dangerously live voltages, keep a maximum voltage difference of 230 V between the channels.

Observe the information on the inductive DC loads in Section 6.1 "Technical specifications".

Section 6.1 Technical specifications

NOTICE

Required measures in the case of inductive DC loads and switching frequencies greater than 0.1 Hz

Install an external freewheel in the form of a diode for switching frequencies greater than 0.1 Hz.

Equipment Manual RQ 4x24VUC/2A CO ST, Edition 02/2019

Switching capacity and service life of contacts

The list shows the switching capacity and lifetime of the relay contacts:

- Resistive DC load 24VDC/1.0A: 0.5 million switching cycles (typical)
- Resistive DC load 24VDC/2.0A: 0.1 million switching cycles (typical)
- Resistive AC load 24V: 0.1 million switching cycles (typical)
- Mechanical service life (free of load): 100 million switching cycles (typical)

The voltage specifications are nominal voltages.

Equipment Manual RQ 3x120VDC-230VAC/5A CO n.i. ST, Edition 01/2024

Section 4.3 Address space

Configuration options of the RQ 3x120VDC-230VAC/5A CO n.i. ST

You can configure the module with STEP 7 (TIA Portal) or with a GSD file. If you configure the module by means of a GSD file, the configurations are available under various short designations/module names; see the table below. The following configurations are possible:

Table 2-6 Configuration options with GSD file

Configuration	Short designation/module name in the GSD file	Configuration software, e.g., with STEP 7 (TIA Portal)		
		Integrated in hardware catalog STEP 7	GSD file PROFINET IO	GSD file PROFIBUS DP
1 x 3-channel without value status	RQ 3x120VDC/230VAC/5A CO n.i. ST V0.0	V16 or higher with HSP 0321 *	X	X
1 x 3-channel with value status	RQ 3x120VDC/230VAC/5A CO n.i. ST V0.0, QI	V16 or higher with HSP 0321 *	X	---

* in compatibility mode of the RQ 3x120VDC-230VAC/5A CO ST (6ES7132-6HC50-0BU0)

RQ Modules Equipment Manuals

Equipment Manual	Edition
RQ 4x24VUC/2A CO ST (6ES7132-6GD51-0BA0)	10/2019
RQ 4x120VDC-230VAC/5A NO MA ST (6ES7132-6MD00-0BB1)	06/2020
RQ 4x120VDC-230VAC/5A NO ST (6ES7132-6HD01-0BB1)	06/2020
RQ 3x120VDC-230VAC/5A CO ST (6ES7132-6HC50-0BU0)	01/2024
RQ 3x120VDC-230VAC/5A CO n.i. ST (6ES7132-6HC70-0BU0)	01/2024

New Section 6.3 Mechanical environmental conditions

The mechanical ambient conditions are specified in the following table as sinusoidal oscillations.

Table 2-7 Test of mechanical environmental conditions

Condition tested	Test standard	Remarks
Vibrations	Vibration test according to IEC 60068-2-6 (Sinus)	Type of vibration: Frequency sweeps with a rate of change of 1 octave/minute. <ul style="list-style-type: none"> 5 Hz ≤ f ≤ 8.4 Hz, 3.5 mm constant amplitude 8.4 Hz ≤ f ≤ 150 Hz, 1 g constant acceleration Duration of oscillation: 10 frequency sweeps per axis, along each of the 3 mutually perpendicular axes
Shock	Shock, tested according to IEC 60068-2-27	Type of shock: Half-sine Shock intensity: 100 m/s ² peak value, 11 ms duration Direction of shock: 3 shocks each in +/- direction, along each of the 3 perpendicular axes
Continuous shock	Shock, tested according to IEC 60068-2-27	Is not supported by the RQ module

Equipment Manual DQ 16x24VDC/0.5A HF, edition 01/2024

Section 6.1 Technical specifications

- **Load resistance range**
 - High limit: 2.4 kΩ (at nominal voltage)

Compatibility of modules

In a spare parts scenario, you can replace a DQ 16x24VDC/0.5A ST digital output module with a DQ 16x24VDC/0.5A HF digital output module without adapting the configuration.

The "DQ 16x24VDC/0.5A HF" digital output module is compatible with the following modules:

- Digital output module DQ 16x24VDC/0.5A ST (6ES7132-6BH00-0BA0)
- Digital output module DQ 16x24VDC/0.5A ST (6ES7132-6BH01-0BA0)

2.5.2 Analog module device manuals

Equipment Manuals for analog input modules

Equipment Manual	Edition
AI 4xI 2-wire 4..20mA HART	11/2014

Section 5.2 "Parameters"

NOTE

Note that the settings in the "Interference frequency suppression" parameter have a direct effect on the cycle time of the module. The analog value is therefore also affected by additionally set filtering via the "Smoothing" parameter.

Equipment Manuals for analog input modules

Equipment Manual	Edition
AI 4xTC HS (6ES7134-6JD00-0DA1)	03/2019

For user calibration with a calibration device, deactivate the "Wire-break check" parameter or function.

Equipment Manuals for analog input modules

Equipment Manual	Edition
AI 4xU/I 2-wire ST (6ES7134-6HD01-0BA1)	09/2019
AI 2xI 2/4-wire ST (6ES7134-6GB00-0BA1)	04/2018
AI 2xU/I 2/4-wire HF (6ES7134-6HB00-0CA1)	12/2015
AI 4xI 2/4-wire ST (6ES7134-6GD01-0BA1)	09/2018

New section in Appendix B: "Measured values for wire break"

Table 2-8 Measured values at a wire break depending on enabled diagnostics

Programmable diagnostics		Measured value		Explanation
Wire break	Underflow			
Enable	Enable	32767	7FFF _H	The "wire break" diagnostics is reported, because this has a higher priority.
Disable	Enable	-32768	8000 _H	The "Lower limit violated" diagnostics is reported.
Disable	Disable	-32768	8000 _H	No diagnostics reported.

Equipment Manual Analog Input Module AI 4xRTD/TC 2-/3-/4-wire HF, Edition 07/2021

Section "Measurement types and measuring ranges"

Table 2-9 Using PTC resistors

Property	Technical specifications	Remarks
Switching points	Behavior with rising temperature	
	< 550 Ω	Normal range: • SIMATIC S7: Bit 0 = "0", Bit 2 = "0" (in the PII)
	550 Ω to 1650 Ω	Prewarning range: • SIMATIC S7: Bit 0 = "0", Bit 2 = "1" (in the PII)
	> 1650 Ω	Response range: • SIMATIC S7: Bit 0 = "1", Bit 2 = "0" (in the PII)
	Behavior with falling temperature	
	> 750 Ω	Response range: • SIMATIC S7: Bit 0 = "1", Bit 2 = "0" (in the PII)
	750 Ω to 540 Ω	Prewarning range: • SIMATIC S7: Bit 0 = "0", Bit 2 = "1" (in the PII)
< 540 Ω	Normal range: • SIMATIC S7: Bit 0 = "0", Bit 2 = "0" (in the PII)	

¹ Below 23 kΩ

Property	Technical specifications	Remarks
Switching points	Behavior after short-circuit	
	< 18 Ω	<ul style="list-style-type: none"> SIMATIC S7: Bit 7 (IB x) = "1", Bit 0 = "0" and Bit 2 = "0"
(RRT-5) °C (RRT+5) °C (RRT+15) °C Measuring voltage/ voltage at the PTC	Max. 550 Ω Min. 1330 Ω Min. 4000 Ω Max. 7.5 V ¹	TNF = Rated response temperature of the sensor (according to DIN/VDE 0660)

¹ Below 23 kΩ

Equipment Manual AI 2xUI 2-/4-wire HF analog input module, Edition 05/2021

Connection: Voltage and current measurement 3-wire connection

The following figure shows the schematic circuit diagram and an example of the pin assignment of the analog input module AI 2xUI 2-/4-wire HF on the BaseUnit BU type A0/A1.

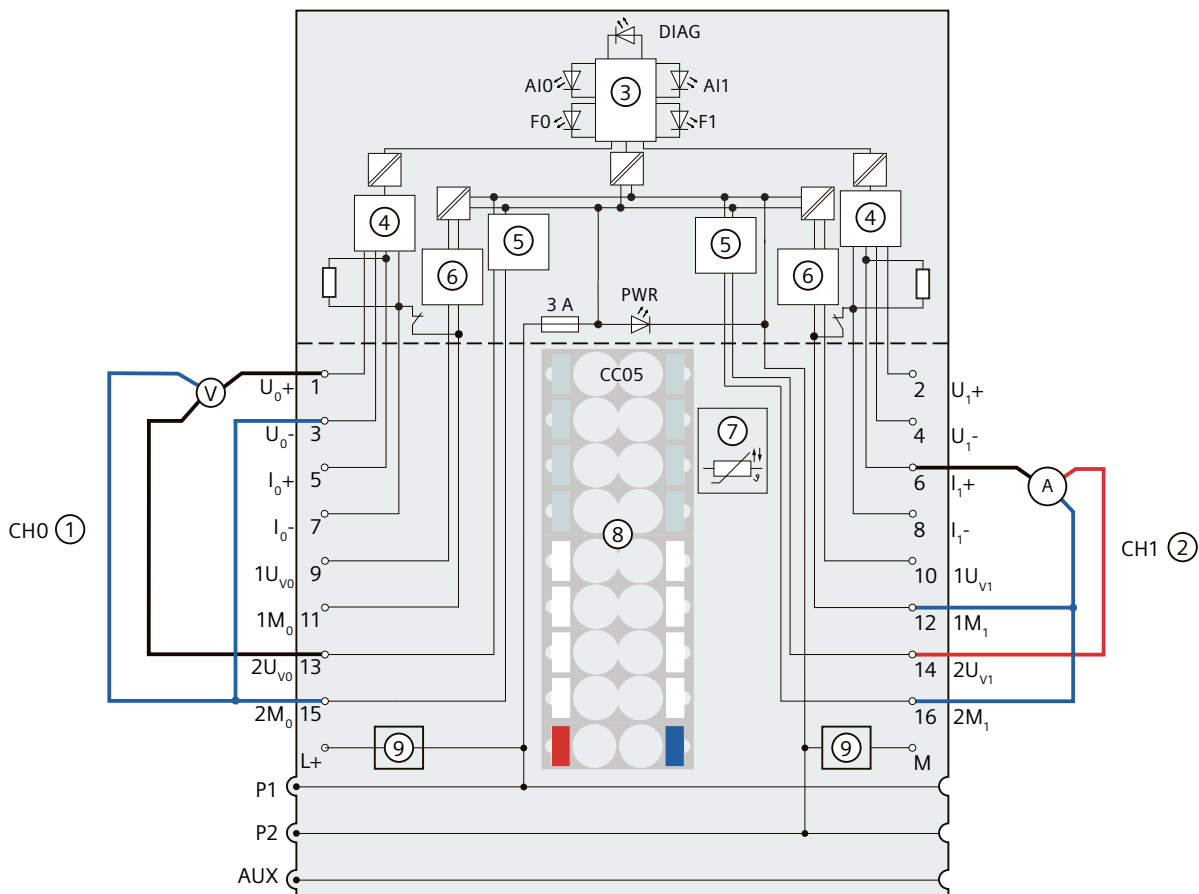

- | | | | |
|---|---|----------|--|
| ① | 3-wire connection for voltage measurement | I_{n+} | Current input positive, channel n |
| ② | 3-wire connection for current measurement | I_{n-} | Current input negative, channel n |
| ③ | Backplane bus interface | U_{Vn} | Supply voltage, channel n |
| ④ | Analog-to-digital converter (ADC) | M_n | Reference ground to U_{Vn} , channel n |

⑤	Current limitation (4-wire or 3-wire)	L+	24 V DC (infeed only with light-colored BaseUnit)
⑥	Current limitation (2-wire)	P1, P2, AUX	Internal self-assembling voltage buses Connection to left (dark-colored BaseUnit) Connection to left interrupted (light-colored BaseUnit)
⑦	Temperature recording for BU type A1 only (function cannot be used for this module)	DIAG	Diagnostics LED (green, red)
⑧	Color-coded label with color code CC05 (optional)	AI0, AI1	Channel status LED (green)
⑨	Supply voltage filter circuit (only when light-colored BaseUnit is present)	F0, F1	Channel fault LED (red)
U_{n+}	Voltage input positive, channel n	PWR	Power LED (green)
U_{n-}	Voltage input negative, channel n		

Figure 2-8 Wiring and schematic circuit diagram for voltage measurement 3-wire connection

Equipment Manual for Analog Input Module AI 2xI 2-/4-wire ST, Edition 04/2018

Connection: Current measurement 3-wire connection (3-wire transducer)

The following figure shows the block diagram and an example of the pin assignment of the analog input module AI 2xI 2-/4-wire ST on the BaseUnit BU type A0/A1.

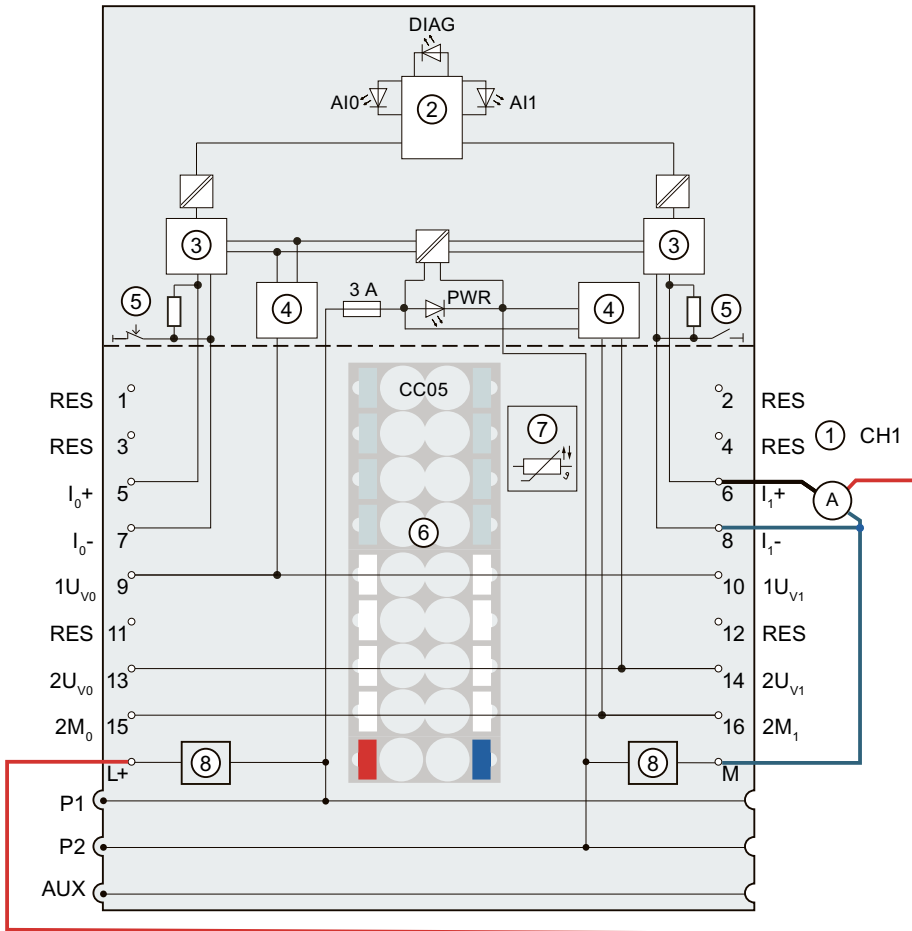

①	3-wire connection for current measurement (3-wire transducer)	$1U_{Vn}$	Supply voltage (2-wire transducer), channel n
②	Backplane bus interface	$2U_{Vn}$	Supply voltage (4-wire transducer), channel n
③	Analog-to-digital converter (ADC)	$2M_n$	Reference potential (4-wire transducer)
④	Current limitation	RES	Reserve, must remain unused for future function extensions
⑤	Switchover 2-wire / 4-wire	L+	24 V DC (infeed only with light-colored BaseUnit)
⑥	Color-coded label with color code CC05 (optional)	P1, P2, AUX	Internal self-assembling voltage buses Connection to left (dark-colored BaseUnit) Connection to left interrupted (light-colored BaseUnit)
⑦	Temperature recording for BU type A1 only (function cannot be used for this module)	DIAG	Diagnostics LED (green, red)

⑧	Supply voltage filter circuit (only when light-colored BaseUnit is present)	AI0, AI1	Channel status LED (green)
I _{n+}	Current input positive, channel n	PWR	Power LED (green)
I _{n-}	Current input negative, channel n		

Figure 2-9 Wiring and block diagram for current measurement 3-wire connection (3-wire transducer)

NOTE

With this interconnection, the sensor supply is not limited. Up to a total current of 200 mA, you can use $2U_{Vn}$ to power the encoder.

NOTE

For 3-wire connection, configure the parameter "Measurement type/range" with "Current (4-wire transducer) 0..20 mA" or "Current (4-wire transducer) 4..20 mA".

"Parameters" section

You can only assign the parameters diagnostics on a module-by-module basis.

Equipment Manual AI 4xTC HS, Edition 03/2019**"Parameters" section**

Table 2-10 Configurable parameters and their defaults (GSD file)

Parameters	Value range	Default	Reconfiguration in RUN	Scope with configuration software, e.g. STEP 7 (TIA Portal)	
				GSD file PROFINET IO	GSD file PROFIBUS DP
Fixed reference temperature	0 °C	0 °C	No	Channel	-

"Technical specifications" section

The abbreviation SFU stands for interference frequency suppression.

Equipment Manual AI Energy Meter 480VAC/CT HF, Edition 03/2021

Wiring and block diagram

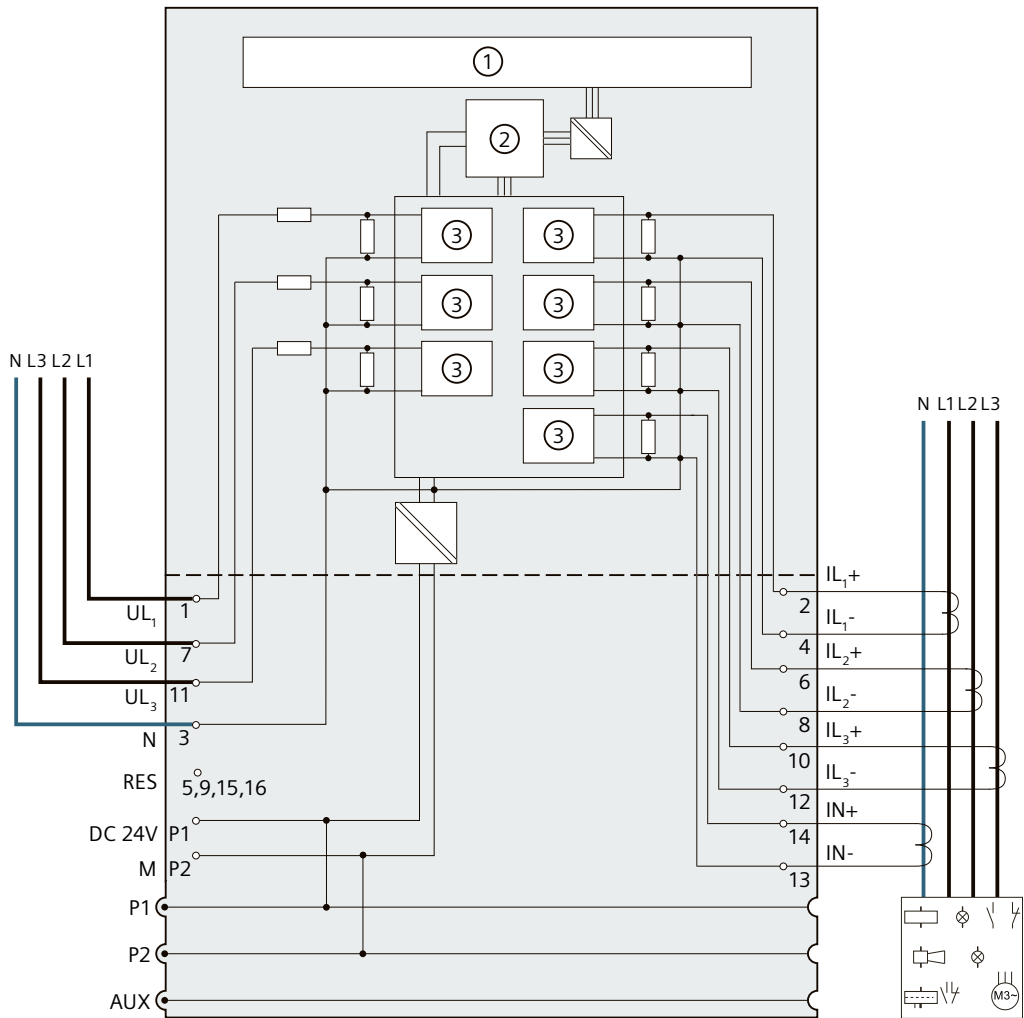

①	Backplane bus interface	UL _n	Connection voltage
②	Microcontroller	IL _n + / IL _n -	Connection of current transformers
③	Analog-to-digital converter (ADC)	N, IN+ / IN-	Neutral conductor
P1, P2, AUX	Internal self-assembling voltage buses Connection to left (dark-colored BaseUnit) Connection to left interrupted (light- colored BaseUnit)	RES	Reserve, must remain unused for future function extensions

Equipment Manual AI Energy Meter 480VAC/RC HF

Wiring and block diagram

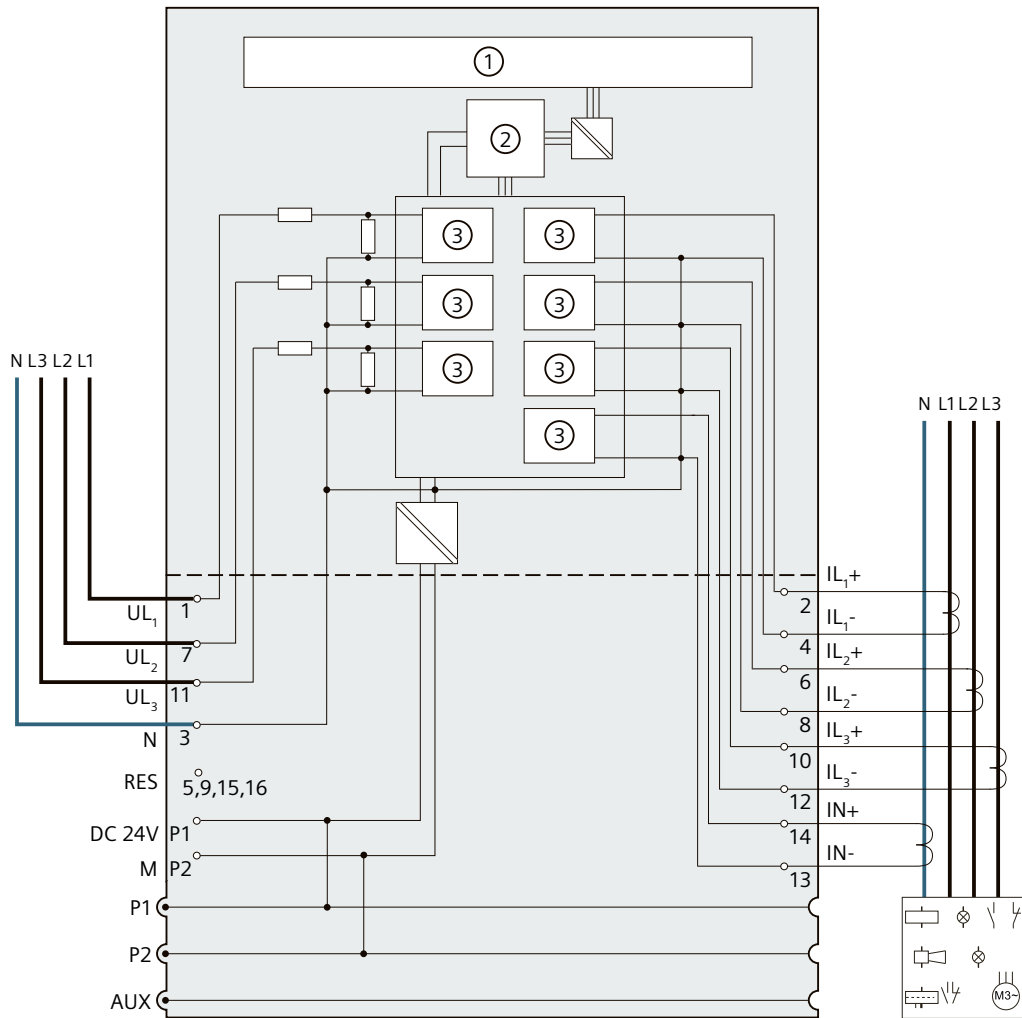

①	Microcontroller	UL_n	Connection voltage
②	Backplane bus interface	$IL_{n+} /$ IL_{n-}	Connection of current/voltage transformers and Rogowski coils
③	Analog-to-digital converter (ADC)	N, $IN+$ / $IN-$	Neutral conductor
P1, P2, AUX	Internal self-assembling voltage buses Connection to left (dark-colored BaseUnit) Connection to left interrupted (light-colored BaseUnit)	RES	Reserve, must remain unused for future function extensions

Equipment Manual AI Energy Meter 480VAC ST, Edition 12/2015

For configuration with STEP 7 V13 or higher (TIA Portal), real values between -7×10^{28} and $+7 \times 10^{28}$ can be input. This is true for configuration via HSP and via GSD file (PROFINET).

For configuration with STEP 7 V5.5 SP4 as of HF7, configuration by means of GSD file (PROFINET) with REAL values of -1.175×10^{38} to $+3.402 \times 10^{38}$ is possible.

With STEP 7 SP4 to HF6, parameter assignment of REAL values is not possible. Functions that require REAL values are not available in this case.

Equipment Manuals AI Energy Meter 480VAC/CT HF, Edition 03/2021, and AI Energy Meter 480VAC/RC HF, Edition 03/2021

Below the "Measured variables for data records and user data" table in the section "Measured variables for connection type" it should correctly read in Italian:

⁴ Valore medio aritmetico in virgola mobile calcolato su 10 s, disponibile se $UL-N > 3V$

Equipment Manuals AI Energy Meter

Equipment Manual	Edition
AI Energy Meter 480VAC/CT HF	03/2021
AI Energy Meter 480VAC/RC HF	03/2021

Section 7.2.2 "Quality information with measured value IDs"

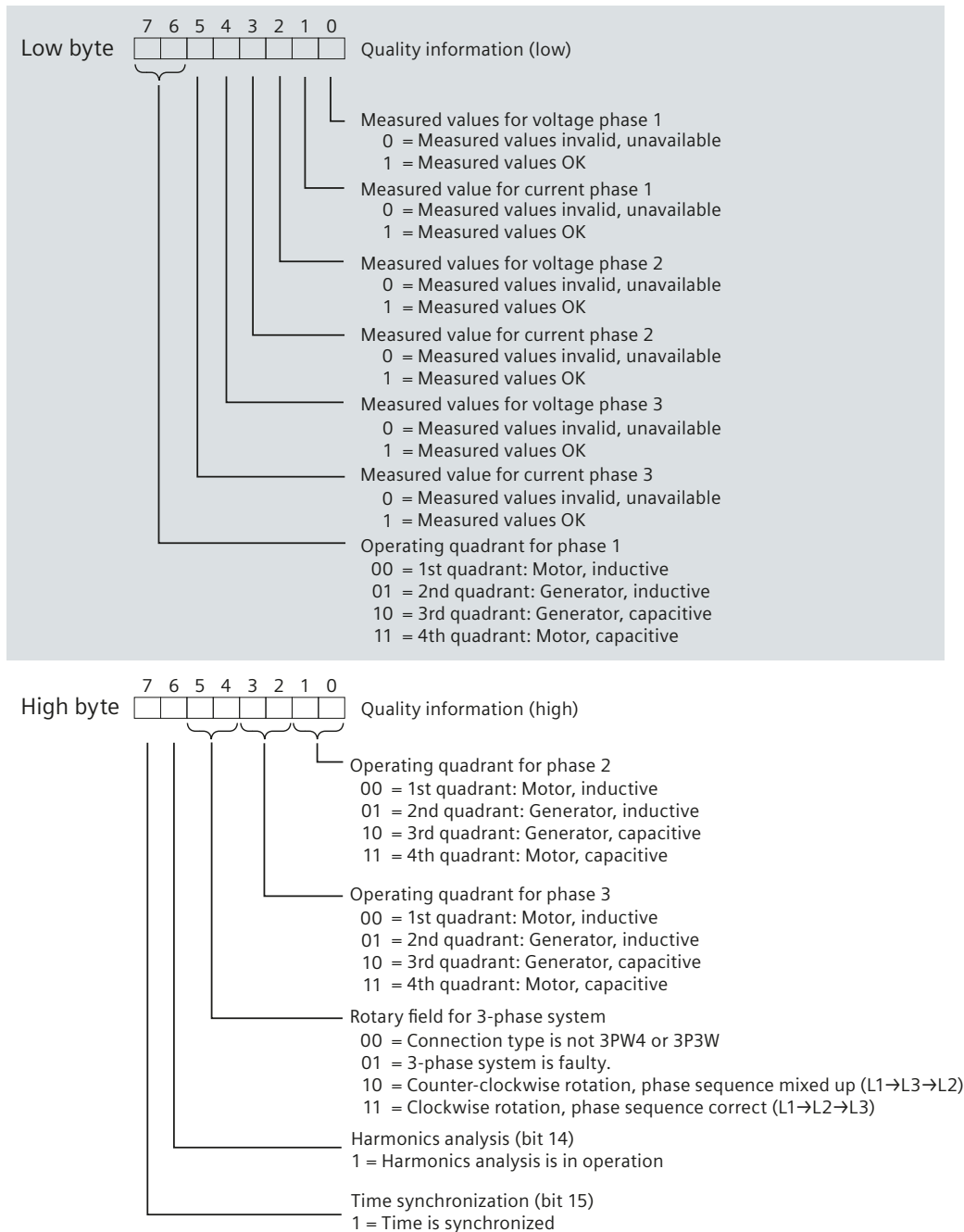

Figure 2-10 Quality information for low and high byte of the measured value ID 65503

Section "7.2.3 Operating quadrant"

The figure below shows the quality information of the operating quadrants.

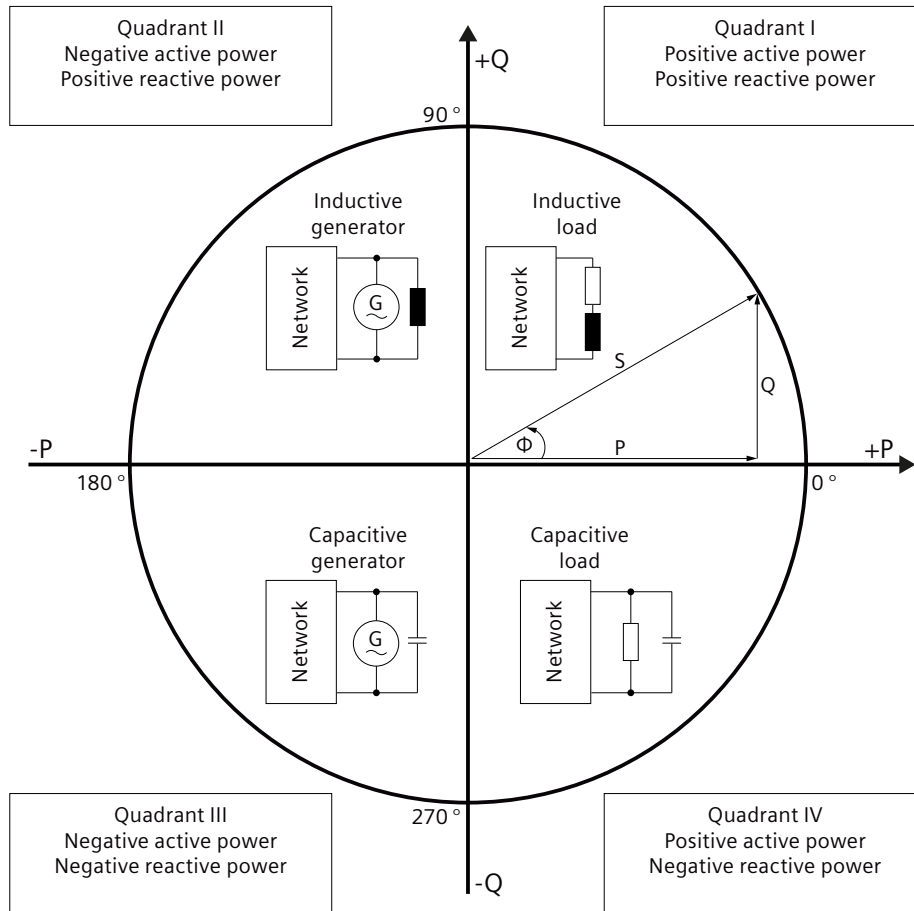

Figure 2-11 Quadrant in the quality bits

Section "7.2.4 Notes for the detection of wiring errors and incorrect rotating field"

Requirements

Detecting the rotating field requires 3-phase operation with 3P4W or 3P3W connection types.

The "See also" paragraph is omitted.

Section "8 Energy counter"

Introduction

"Outflow" describes the regenerative operation of the connected system.

"Inflow" describes the motor operation of the connected system.

Section 9.2.1 "Start values for operating hours counter"

Byte 158 ... byte 169: Start values for operating hours counter

The start values for operating hours counters in data record 143 are 32-bit floating point number. The format corresponds to the data type REAL in S7-1200 and in S7-1500.

Appendix F.1 "Tips and tricks"

Rotating field

To recognize wiring errors and evaluate the generated rotating field, use the combined measurement functions from the section "Notes for the recognition of wiring errors and incorrect rotating field".

Equipment Manuals AI Energy Meter 400VAC ST, Edition 12/2015; AI Energy Meter 480VAC ST, Edition 12/2015

Requirements for the operation of the AI Energy Meter on slot 1 of the ET 200SP:

Interface module / CPU	AI Energy Meter 400VAC ST (6ES7134-6PA01-0BD0)	AI Energy Meter 480VAC ST (6ES7134-6PA20-0BD0)
IM 155-6 PN BA (6ES7155-6AR00-0AN0)	Can be operated on slot 1 for all IM 155-6 PN BA	
IM 155-6 PN ST (6ES7155-6AU00-0BN0)	Can be operated on slot 1 for IM 155-6 PN ST from firmware version V3.1 and higher and functional status FS 07	
IM 155-6 PN HF (6ES7155-6AU00-0CN0)	Can be operated on slot 1 for IM 155-6 PN HF from firmware version V3.0 and higher and functional status FS 05	
IM 155-6 DP HF (6ES7 155-6BU00-0CN0)	Can be operated on slot 1 for IM 155-6 DP HF from firmware version V3.0 and higher	
CPU 1510SP-1 PN, CPU 1512SP-1 PN, CPU 1515SP PC	Can be operated on slot 1 for all CPUs	

Incorrect value range for information on power (INT variables)

Refers to the table of measured quantities in Appendix B and the tables of useful data variants in Appendix D.

Correct value range: -32768 to 32767

Product overview, Figure 2-1 Use of the AI Energy Meter

Display incorrect.

Replace figures as follows:

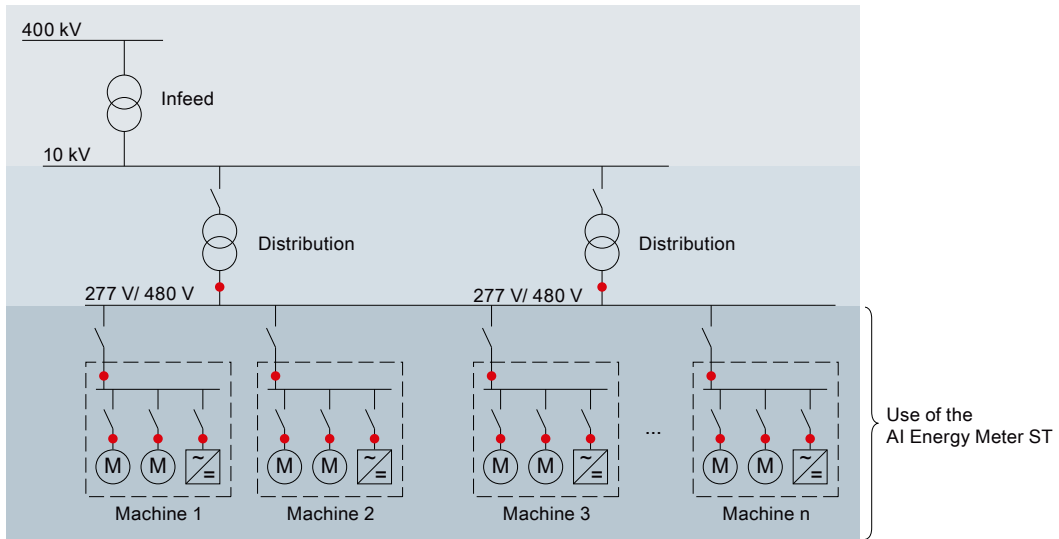

● Measuring points in the system

Figure 2-12 Use of the AI Energy Meter 480VAC ST

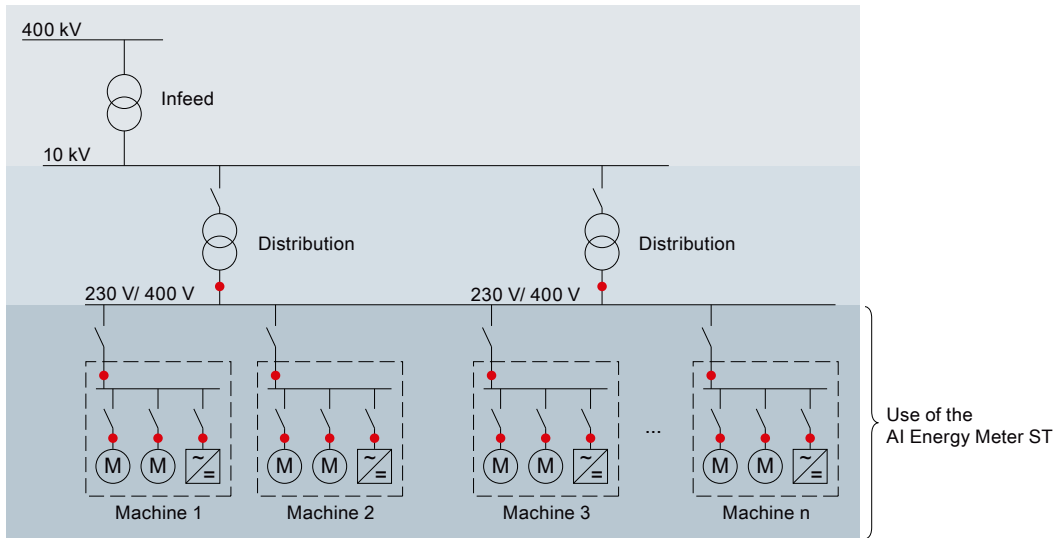

● Measuring points in the system

Figure 2-13 Use of the AI Energy Meter ST 400V

Section 3.1 Wiring and block diagram, paragraph on Fuse protection of the connection lines

AI Energy Meter 400VAC ST, replace set with:

If the cables are short-circuit proof according to IEC 61439-1:2009, e.g. in a conduit or on separate cable trays, separate line protection for the AI Energy Meter 400VAC ST can be omitted.

AI Energy Meter 480VAC ST, replace set with:

If the cables are short-circuit proof according to IEC 61439-1:2009, e.g. in a conduit or on separate cable trays, separate line protection for the AI Energy Meter 480VAC ST can be omitted.

Section 3.1 Wiring and block diagram, Figure 3-1

Replace wiring diagram, add note:

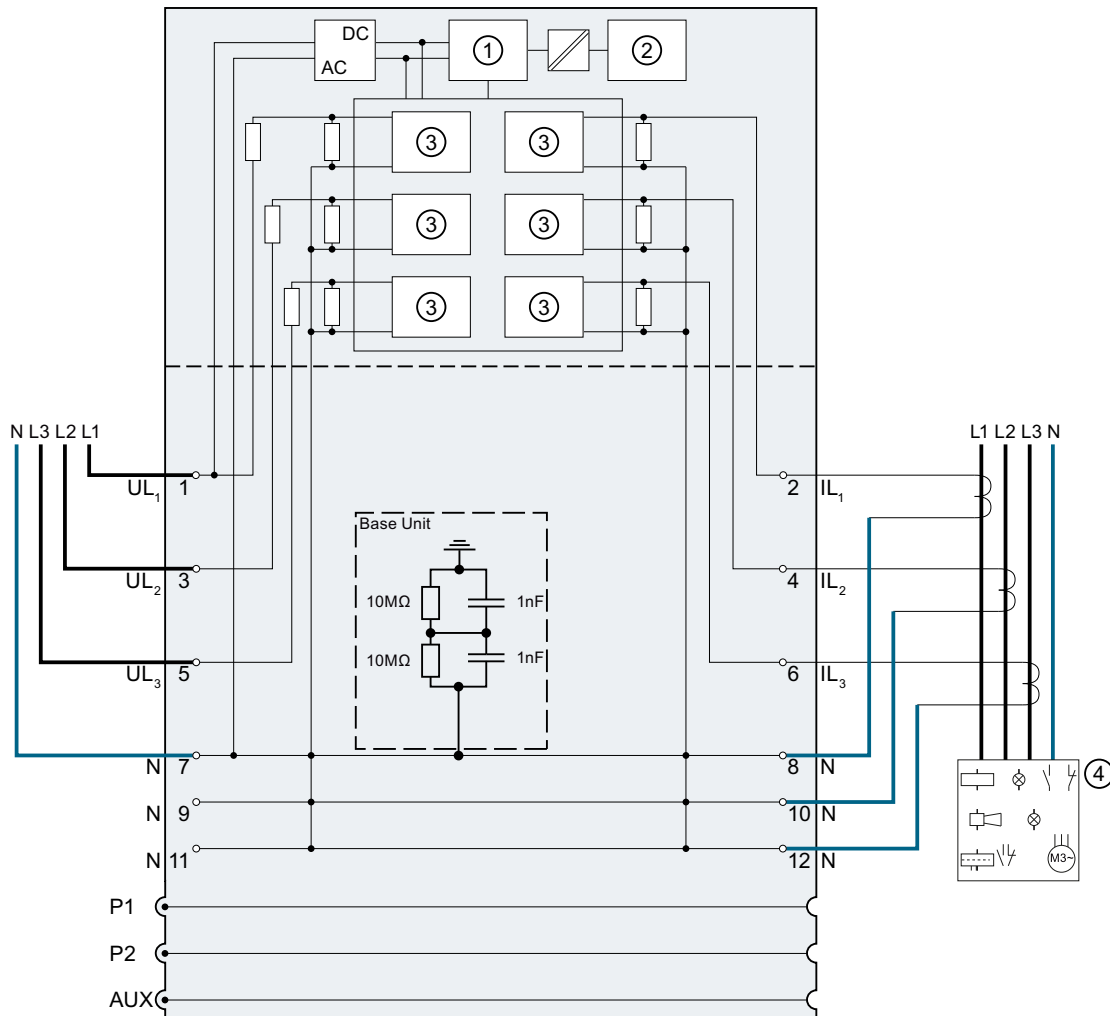

①	Microcontroller	UL _n	Voltage connection
②	Backplane bus interface	IL _n	Current connection
③	Analog-to-digital converter (ADC)	N	Neutral conductor
④	Power measurement		

Figure 2-14 Block diagram of the AI Energy Meter 480VAC ST

NOTE

The BaseUnit of the Energy Meter 400/480VAC, 6ES7193-6BP00-0BDO, BU20-P12+A0+0B, contains a connection from N to FE, or to the potential connected to the DIN rail. This connection consists of two Y2 capacitors in series, each with a capacitance of 1 nF, and two resistors in parallel, each with a resistance of 10 MOhm.

Equipment Manual for Energy Meter 480VAC ST, Edition 12/2015

In the Equipment Manual for Energy Meter 480VAC ST, the measured value ID and the associated measured variables for the complete performance are reversed. The correct association is shown in the table below:

Measured value ID	Measured variables	Unit
34	Total active power L1L2L3	W
35	Total reactive power L1L2L3	var
36	Total apparent power L1L2L3	VA
65	Max. total active power	W
66	Max. total reactive power	var
67	Max. total apparent power	VA
95	Min. total active power	W
96	Min. total reactive power	var
97	Min. total apparent power	VA

If you use the user-data mapping via data record DS 130, note that the texts for the measured variables are also displayed incorrectly during configuration.

During configuration of the measured variables for the total active, reactive, and apparent power, select the following texts:

Desired measured variable for the user-data mapping	Text to select during configuration
Total active power L1L2L3	Total apparent power L1L2L3 (ID00034)
Total reactive power L1L2L3	Total active power L1L2L3 (ID00035)
Total apparent power L1L2L3	Total reactive power L1L2L3 (ID00036)
Max. total active power	Max. total apparent power (ID00065)
Max. total reactive power	Max. total active power (ID00066)
Max. total apparent power	Max. total reactive power (ID00067)
Min. total active power	Min. total apparent power (ID00095)
Min. total reactive power	Min. total active power (ID00096)
Min. total apparent power	Min. total reactive power (ID00097)

The project configuration modification described above is no longer required if the following tools and GSD files are used:

- STEP 7 (TIA Portal) as of V14
- STEP 7 V5.5 SP4 or higher with HSP 0227
- GSD file GSDML-V2.32-ET200SP-20160706

Section 11.1 Phase-related measured values

Assignment of the user data variants swapped between L1 and L3.

Correct assignment:

- Phase-specific measurement Phase L1 with user data variants 158 (9E_H) and 159 (9F_H)
- Phase-specific measurement Phase L2 with payload variants 156 (9C_H) and 157 (9D_H)
- Phase-specific measurement Phase L3 with user data variants 154 (9A_H) and 155 (9B_H)

Appendix D User data variants

Table D-13 Basic energy counter measurement variables (periodic) Overflow counter (ID 239 or EFH).

Replace measured value IDs:

Table 2-11 Basic energy-counter-measurement variables (periodic) overflow counter

Byte	Allocation	Data type	Unit	Value range	Measured value ID
0	Payload variant	BYTE	-	239 (EFH)	-
1	Quality information = QQ ₁ I ₃ U ₃ I ₂ U ₂ I ₁ U ₁	BYTE	Bit string	qq xx xx xx	-
2 ... 3	Overflow counter for active energy inflow L1	UINT	-	0 ... 65535	61190
4 ... 5	Overflow counter for active energy outflow L1	UINT	-	0 ... 65535	61191
6 ... 7	Overflow counter for reactive energy inflow L1	UINT	-	0 ... 65535	61192
8 ... 9	Overflow counter for reactive energy outflow L1	UINT	-	0 ... 65535	61193
10 ... 11	Overflow counter for apparent energy L1	UINT	-	0 ... 65535	61194
12 ... 13	Overflow counter for active energy inflow L2	UINT	-	0 ... 65535	61210
14 ... 15	Overflow counter for active energy outflow L2	UINT	-	0 ... 65535	61211
16 ... 17	Overflow counter for reactive energy inflow L2	UINT	-	0 ... 65535	61212
18 ... 19	Overflow counter for reactive energy outflow L2	UINT	-	0 ... 65535	61213
20 ... 21	Overflow counter for apparent energy L2	UINT	-	0 ... 65535	61214
22 ... 23	Overflow counter for active energy inflow L3	UINT	-	0 ... 65535	61230
24 ... 25	Overflow counter for active energy outflow L3	UINT	-	0 ... 65535	61231
26 ... 27	Overflow counter for reactive energy inflow L3	UINT	-	0 ... 65535	61232
28 ... 29	Overflow counter for reactive energy outflow L3	UINT	-	0 ... 65535	61233
30 ... 31	Overflow counter for apparent energy L3	UINT	-	0 ... 65535	61234

Equipment Manuals for analog output modules

Equipment Manual	Edition
Analog output module AQ 2xU/I HS	09/2016
Analog output module AQ 4xU/I ST	03/2016

"Representation of analog values in the current output ranges" section

Table 2-12 Current output ranges 4 to 20 mA

Values			Current output range	Range
	Dec.	Hex.	4 to 20 mA	
118.5149 %	32767	7FFF	21 mA	Overflow*
	29377	72C1		
106.25 %	29376	72C0	21 mA	Overrange
	27649	6C01	20 mA + 578.7 nA	
100 %	27648	6C00	20 mA	Rated range
75 %	20736	5100	16 mA	
0.003617 %	1	1	4 mA + 578.7 nA	
0 %	0	0	4 mA	

* Outputs positive maximum value or negative minimum value

Values			Current output range	Range
	-1	FFFF	3.9995 mA	Underrange
-2.5 %	-692	FD4C	3.6 mA	
	-693	FD4B	3.6 mA	Underflow*
-118.519 %	-32768	8000		

* Outputs positive maximum value or negative minimum value

Equipment Manuals for analog input modules

Equipment Manual	Edition
AI 4xU/I 2-wire ST (6ES7134-6HD01-0BA1)	09/2019
AI 2xI 2/4-wire ST (6ES7134-6GB00-0BA1)	04/2018
AI 4xI 2/4-wire ST (6ES7134-6GD01-0BA1)	09/2018
AI 4xTC HS (6ES7134-6JD00-0DA1)	03/2019

"Diagnostic messages" section

Diagnostic messages in the measured value of analog input modules

Each analog input module supplies the measured value 7FFF_H or 8000_H depending on the parameter assignment when an error is detected.

Equipment Manual AI 4xTC HS (6ES7134-6JD00-0DA1)

New section in Appendix B: "Measured values for wire break and reference channel mode"

Table 2-13 Measured values for a wire break depending on enabled diagnostics and parameters in TC operating mode

Parameters			Measured value		Explanation
Wire break check	Diagnostics wire break	Diagnostics underflow			
Enable	Enable	*	32767	7FFF _H	The "wire break" diagnostics is reported.
Enable	Disable	*	32767	7FFF _H	No diagnostics reported. A wire break check is carried out (i.e. test current flows).
Disable	Disable	*	Undefined		No "wire break" diagnostics is reported. No wire break check is carried out (i.e. no test current flows). This is required to calibrate thermocouples, since the test current necessary for a wire break check leads to measurement errors during calibration.

* Parameter assignment not relevant

Table 2-14 Measured values for a wire break in a TC measurement with enabled reference junction (reference channel) depending on enabled diagnostic information and parameters

Case	Parameters					Measured value			
	Reference channel		TC channel			Reference channel		TC channel	
	Diagnostics Wire break	Diagnostics underflow	Wire break check	Diagnostics wire break	Diagnostics underflow				
1	Enable ³	* ³	*	*	* ¹	32767 ³	7FFF _H ³	32767 ²	7FFF _H ²
2	Disable ³	* ³	*	*	* ¹	32767 ³	7FFF _H ³	32767 ²	7FFF _H ²
3	*	*	Enable ³	Enable ³	* ³	Valid	Valid	32767 ³	7FFF _H ³
4	*	*	Enable ³	Disable ³	* ³	Valid	Valid	32767 ³	7FFF _H ³
5	*	*	Disable ³	Disable ³	* ³	Valid	Valid	Undefined ³	

* Parameter assignment not relevant

¹ Diagnostics is suppressed in the event of a reference channel error.

² Measured value taken from the reference channel

³ Channel with line break

Explanations of the cases:

Case	Reference channel	TC channel
1	The "wire break" diagnostics is reported. This has a higher priority than the "Underflow" diagnostics.*	The "Reference channel error" diagnostics is reported if this is enabled. Where own pending diagnostic information ("overflow" or "underflow") is reported as outgoing. Wire break diagnostics is detected independently of the measured value and has the same priority as the "Reference channel error" diagnostics. Both items of diagnostic information can be pending simultaneously. The measured value of the reference channel (RTD channel) is adopted for the TC channel. The validity of the measured value of the TC channel is irrelevant.
2	No diagnostics reported. A wire break check is carried out (i.e. test current flows).*	<i>Behavior corresponds to case 1.</i>
3	<i>(Measured values are in the valid measuring range)</i>	The "wire break" diagnostics is reported.*
4	<i>(Measured values are in the valid measuring range)</i>	No diagnostics reported. A wire break check is carried out (i.e. test current flows).*
5	<i>(Measured values are in the valid measuring range)</i>	No "wire break" diagnostics is reported. No wire break check is carried out (i.e. no test current flows). This is required to calibrate thermocouples, since the test current necessary for a wire break check leads to measurement errors during calibration.*

* Channel with wire break

2.5.3 Communications module manuals

Communications module CM DP, Edition 12/2014

The communications module CM DP supports the PROFIsafe protocol V2.

Exception: Fail-safe modules that only support PROFIsafe V1 mode.

Communications module IO-Link Master CM 4xIO-Link, Edition 10/2017

Section "Connecting, Wiring and block diagram"

Connection: 2-wire and 3-wire connection in DQ operating mode:

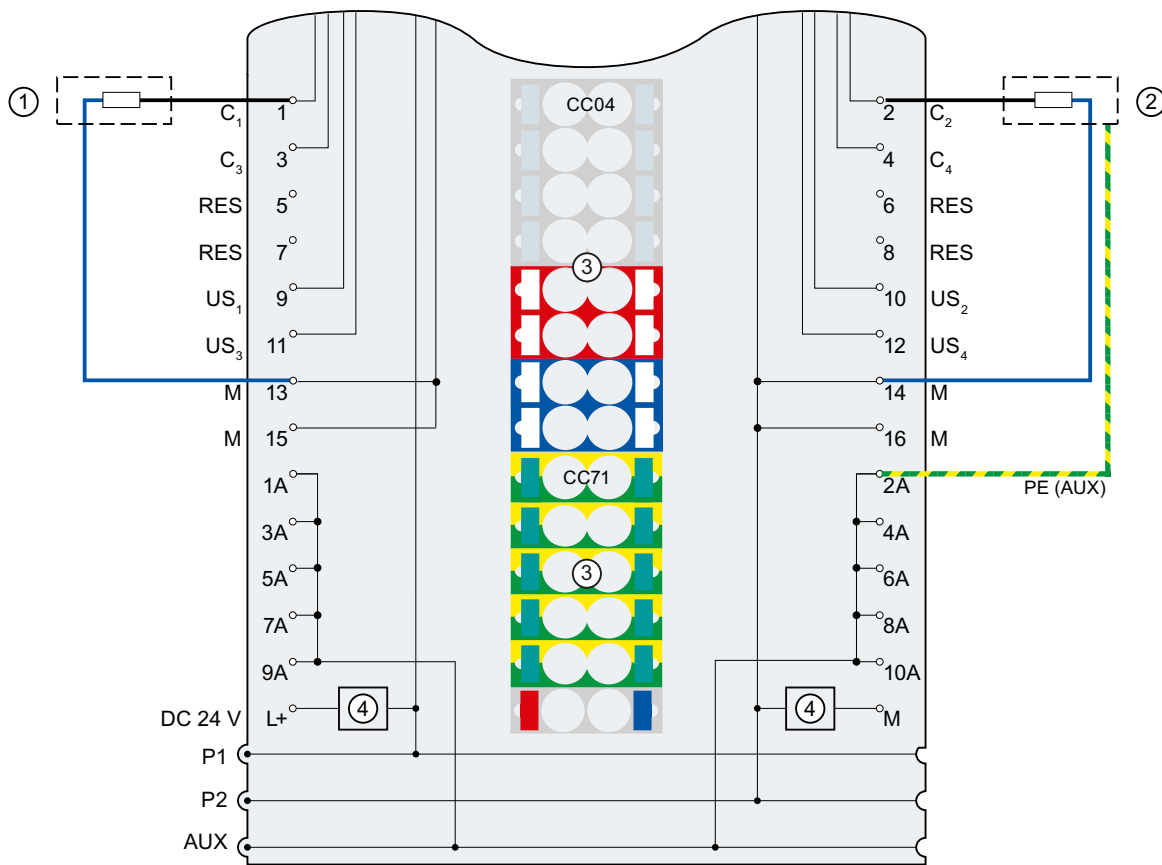

①	2-wire connection	1 A ... 10 A	AUX terminals
②	3-wire connection	PE (AUX)	Protective conductor connection
③	Color-coded labels with color code CC04 and CC71 (optional)	P1, P2, AUX	Internal self-assembling voltage buses Connection to the left (dark-colored BaseUnit) Connection to the left interrupted (light-colored BaseUnit)
④	Supply voltage filter circuit (only when light-colored BaseUnit is present)	C _n	Communication signal, DI, DQ
24 V DC	Supply voltage L+ (infeed for light-colored BaseUnit only)	RES	Reserved, must not be assigned
M	Ground	US _n	Supply voltage (positive)

Figure 2-15 Terminal assignment for 2-wire and 3-wire connection in DQ operating mode

Section "Replacement of the IO-Link Master CM 4xIO-Link communication module with an electronic coding element type H"

The "IO_LINK_MASTER" function block is now called "LIOLink_Master".

Using ET 200SP higher than 2 000 m above sea level.

3

3.1 Ambient temperature and installation altitude

Extension of the temperature range and the installation altitude

The previously permissible range of ambient temperature of 0 °C to 60 °C has been extended for a large number of modules to range of ambient temperature of -30 °C to 60 °C or -25 °C to 60 °C (in each case without condensation or icing). In addition, depending on the module, the permitted installation altitudes has been extended to installation heights of up to 5 000 meters.

The accessory components offered for ET 200SP (labeling strips, shield terminals, mounting rails, front connectors, etc.) can also be used down to -30 °C and for altitudes up to 5 000 m. The following tables show an overview of the current climatic ambient conditions for ambient temperature and installation altitude of modules of the ET 200SP product family.

Reference

The current status of the respective modules can be found in the online published technical specifications.

In general, the module-dependent extended climatic operating conditions are described in the "Technical specifications" section of the respective modules in the equipment manuals.

Constraints on operation of ET 200SP at altitudes > 2 000 m are described in SIMATIC ET 200SP Distributed I/O System

(<https://support.industry.siemens.com/cs/ww/en/view/58649293>).

Currently valid markings and approvals

NOTE

Information printed on the components of the ET 200SP automation system

The markings and approvals printed on the components of the ET 200SP automation system are currently based on operation at an altitude of up to 2,000 m. The fail-safe modules are certified for operation in safety mode up to the maximum altitudes indicated in the tables (according to IEC 61508:2010, ISO 13849-1:2015 and IEC 62061:2005/A2:2015).

The fail-safe CPUs are certified for use in safety mode up to 3 000 m or 5 000 m.

Impact on module availability

The higher cosmic radiation present during operation at altitudes over 2,000 m above sea level also starts to have an effect on the error rate of electronic components (so-called soft error rate). For F-modules in particular, this can result in a transition of the modules to safe state in rare cases. However, the functional safety of the modules is fully retained.

Safety parameters

The safety parameters specified in the Equipment Manual (PFD_{avg}, PFH values) already reflect the influence of higher cosmic radiation (soft error rate) for operation up to 4000 m above sea level.

Shipping and storage conditions for modules

ET 200SP meets the requirements of IEC 61131-2 regarding transport and storage conditions. The following information applies to modules that are shipped and/or stored in their original packaging.

Type of condition	Permitted range
Air pressure	1140 to 540 hPa (corresponds to an altitude of -1 000 to 5 000 m above sea level)

3.2 Listing of the modules

CPUs

Type	Name	Article number	Ambient temperature			Maximum installation altitude above sea level [m]
			Lower limit [°C]	Upper limit [°C]	As of revision	
CPU	CPU 1510 SP-1 PN	6ES7510-1DJ01-0AB0	-25	+60 °C	FS 05	5,000
CPU	CPU 1512 SP-1 PN	6ES7512-1DK01-0AB0	-25	+60 °C	FS 05	5,000
CPU	CPU 1510 SP F-1 PN	6ES7510-1SJ01-0AB0	-25	+60 °C	FS 05	5,000
CPU	CPU 1512 SP F-1 PN	6ES7512-1SK01-0AB0	-25	+60 °C	FS 05	5,000
CPU	CPU 1510 SP-1 PN	6ES7510-1DK03-0AB0	-30	+60 °C	FS 01	5 000
CPU	CPU 1512 SP-1 PN	6ES7512-1DM03-0AB0	-30	+60 °C	FS 01	5 000
CPU	CPU 1514SP-2 PN	6ES7514-2DN03-0AB0	-30	+60 °C	FS 01	5 000
CPU	CPU 1514SP T-2 PN	6ES7514-2VN03-0AB0	-30	+60 °C	FS 01	5 000
CPU	CPU 1510 SP F-1 PN	6ES7510-1SK03-0AB0	-30	+60 °C	FS 01	5 000
CPU	CPU 1512 SP F-1 PN	6ES7512-1SM03-0AB0	-30	+60 °C	FS 01	5 000
CPU	CPU 1514SP F-2 PN	6ES7514-2SN03-0AB0	-30	+60 °C	FS 01	5 000
CPU	CPU 1514SP TF-2 PN	6ES7514-2WN03-0AB0	-30	+60 °C	FS 01	5 000
CP	CP 1542SP-1	6GK7542-6UX00-0XE0	-30	+60 °C	FS 01	2 000

Using ET 200SP higher than 2 000 m above sea level.

3.2 Listing of the modules

Type	Name	Article number	Ambient temperature			Maximum installation altitude above sea level [m]
			Lower limit [°C]	Upper limit [°C]	As of revision	
CP	CP 1542SP-1 IRC	6GK7542-6VX00-0XE0	-30	+60 °C	FS 01	2 000
CP	CP 1543SP-1	6GK7543-6WX00-0XE0	-30	+60 °C	FS 01	2 000
Open Controller	CPU 1515SP PC, 32-bit	6ES7677-2AA31-0EB0	0	+60 °C	FS 07	2 000
Open Controller	CPU 1515SP PC F, 32-bit	6ES7677-2FA31-0EB0	0	+60 °C	FS 03	2 000
Open Controller	CPU 1515SP PC, WES7P	6ES7677-2AA41-0FB0	0	+60 °C	FS 06	2 000
Open Controller	CPU 1515SP PC, WES7P + HMI (128PT)	6ES7677-2AA41-0FK0	0	+60 °C	FS 06	2 000
Open Controller	CPU 1515SP PC, WES7P + HMI (512PT)	6ES7677-2AA41-0FL0	0	+60 °C	FS 06	2 000
Open Controller	CPU 1515SP PC, WES7P + HMI (2kPT)	6ES7677-2AA41-0FM0	0	+60 °C	FS 06	2 000
Open Controller	CPU 1515SP PC F, WES7P	6ES7677-2FA41-0FB0	0	+60 °C	FS 03	2 000
Open Controller	CPU 1515SP PC F, WES7P + HMI (128PT)	6ES7677-2FA41-0FK0	0	+60 °C	FS 03	2 000
Open Controller	CPU 1515SP PC F, WES7P + HMI (512PT)	6ES7677-2FA41-0FL0	0	+60 °C	FS 03	2 000
Open Controller	CPU 1515SP PC F, WES7P + HMI (2kPT)	6ES7677-2FA41-0FM0	0	+60 °C	FS 03	2 000
Open Controller	CPU 1515SP PC2	6ES7677-2DB42-0GB0	-20	+60 °C	FS 04	2 000
Open Controller	CPU 1515SP PC2 + HMI (128PT)	6ES7677-2DB42-0GK0	-20	+60 °C	FS 04	2 000
Open Controller	CPU 1515SP PC2 + HMI (512PT)	6ES7677-2DB42-0GL0	-20	+60 °C	FS 04	2 000
Open Controller	CPU 1515SP PC2 + HMI (2kPT)	6ES7677-2DB42-0GM0	-20	+60 °C	FS 04	2 000
Open Controller	CPU 1515SP PC2 F	6ES7677-2SB42-0GB0	-20	+60 °C	FS 04	2 000
Open Controller	CPU 1515SP PC2 F + HMI (128PT)	6ES7677-2SB42-0GK0	-20	+60 °C	FS 04	2 000
Open Controller	CPU 1515SP PC2 F + HMI (512PT)	6ES7677-2SB42-0GL0	-20	+60 °C	FS 04	2 000
Open Controller	CPU 1515SP PC2 F + HMI (2kPT)	6ES7677-2SB42-0GM0	-20	+60 °C	FS 04	2 000
Open Controller	CPU 1515SP PC2 (Ready4Linux)	6ES7677-2DB40-0GB0	-20	+60 °C	FS 03	2 000
Open Controller	CPU 1515SP PC2 F (Ready4Linux)	6ES7677-2SB40-0GB0	-20	+60 °C	FS 03	2 000
Open Controller	CPU 1515SP PC2 T	6ES7677-2VB42-0GB0	-20	+60 °C	FS 04	2 000
Open Controller	CPU 1515SP PC2 T + HMI (128PT)	6ES7677-2VB42-0GK0	-20	+60 °C	FS 01	2 000
Open Controller	CPU 1515SP PC2 T + HMI (512PT)	6ES7677-2VB42-0GL0	-20	+60 °C	FS 01	2 000

Type	Name	Article number	Ambient temperature			Maximum installation altitude above sea level [m]
			Lower limit [°C]	Upper limit [°C]	As of revision	
Open Controller	CPU 1515SP PC2 T + HMI (2kPT)	6ES7677-2VB42-0GM0	-20	+60 °C	FS 01	2 000
Open Controller	CPU 1515SP PC2 TF	6ES7677-2WB42-0GB0	-20	+60 °C	FS 04	2 000
Open Controller	CPU 1515SP PC2 TF + HMI (128PT)	6ES7677-2WB42-0GK0	-20	+60 °C	FS 01	2 000
Open Controller	CPU 1515SP PC2 TF + HMI (512PT)	6ES7677-2WB42-0GL0	-20	+60 °C	FS 01	2 000
Open Controller	CPU 1515SP PC2 TF + HMI (2kPT)	6ES7677-2WB42-0GM0	-20	+60 °C	FS 01	2 000

Interface modules

Type	Name	Article number	Ambient temperature			Maximum installation altitude above sea level [m]
			Lower limit [°C]	Upper limit [°C]	As of revision	
IM	IM 155-6 PN BA	6ES7155-6AR00-0AN0	-30	+60 °C	FS 04	5,000
IM	IM 155-6 PN ST incl. BA 2xRJ45	6ES7155-6AA01-0BN0	0	+60 °C	FS 01	5,000
IM	IM 155-6 PN ST	6ES7155-6AU01-0BN0	0	+60 °C	FS 01	5,000
IM	IM 155-6 PN/2 HF	6ES7155-6AU01-0CN0	-30	+60 °C	FS 02	5,000
IM	IM 155-6 PN/3 HF 3-port	6ES7155-6AU30-0CN0	-30	+60 °C	FS 02	5,000
IM	IM 155-6 MF HF	6ES7155-6MU00-0CN0	-30	+60 °C	FS 02	5,000
IM	IM 155-6 PN HS	6ES7155-6AU00-0DN0	-25	+60 °C	FS 02	5,000
IM	IM 155-6 DP HF - Bundle	6ES7155-6BA01-0CN0	0	+60 °C	FS 01	5,000
IM	IM 155-6 DP HF	6ES7155-6BU01-0CN0	0	+60 °C	FS 01	5,000
IM	Server module (spare part)	6ES7193-6PA00-0AA0	-30	+60 °C	FS 07	5,000
BA	BA 2xRJ45	6ES7193-6AR00-0AA0	-30	+60 °C	FS 06	5,000
BA	BA 2xFC	6ES7193-6AF00-0AA0	-30	+60 °C	FS 04	5,000
BA	BA 2xM12	6ES7193-6AM00-0AA0	-30	+60 °C	FS 01	5,000
BA	BA 2 x LC	6ES7193-6AG00-0AA0	-30	+60 °C	FS 05	5,000
BA	BA LC / RJ45	6ES7193-6AG20-0AA0	-30	+60 °C	FS 04	5,000
BA	BA LC / FC	6ES7193-6AG40-0AA0	-30	+60 °C	FS 04	5,000
BA	BA 2xLC-LD	6ES7193-6AG50-0AA0	-30	+60 °C	FS 01	5 000
BA	BA LC-LD/RJ45	6ES7193-6AG60-0AA0	-30	+60 °C	FS 01	5 000
BA	BA LC-LD/M12	6ES7193-6AG70-0AA0	-30	+60 °C	FS 01	5 000

Using ET 200SP higher than 2 000 m above sea level.

3.2 Listing of the modules

Type	Name	Article number	Ambient temperature			Maximum installation altitude above sea level [m]
			Lower limit [°C]	Upper limit [°C]	As of revision	
BA	BA 2xSCRJ	6ES7193-6AP00-0AA0	-25	+60 °C	FS 04	5,000
BA	BA SCRJ/RJ45	6ES7193-6AP20-0AA0	-25	+60 °C	FS 04	5,000
BA	BA SCRJ/FC	6ES7193-6AP40-0AA0	-25	+60 °C	FS 04	5,000
BA	DP connector	6ES7972-0BB70-0XA0	-25	+60 °C	FS 03	2 000
BA	BA-SEND BA 1xFC	6ES7193-6AS00-0AA0	-30	+60 °C	FS 05	2 000

Digital input modules

Type	Name	Article number	Ambient temperature			Maximum installation altitude above sea level [m]
			Lower limit [°C]	Upper limit [°C]	As of revision	
DI	DI 4x120...230VAC ST	6ES7131-6FD01-0BB1	-30	+60 °C	FS 02	2 000
DI	DI 8x24VDC BA	6ES7131-6BF01-0AA0	-30	+60 °C	FS 03	5,000
DI	DI 8x24VDC BA (PU* 10) ¹	6ES7131-6BF01-2AA0	-30	+60 °C	FS 03	5,000
DI	DI 8x24VDC SRC BA	6ES7131-6BF61-0AA0	-30	+60 °C	FS 02	5,000
DI	DI 8x24VAC/48VUC BA	6ES7131-6CF00-0AU0	-30	+60 °C	FS 02	4,000 (48 Vac/48 Vdc)
DI	DI 8x24VDC ST	6ES7131-6BF01-0BA0	-30	+60 °C	FS 02	5,000
DI	DI 8x24VDC ST (PU* 10) ¹	6ES7131-6BF01-2BA0	-30	+60 °C	FS 02	5,000
DI	DI 8x24VDC HF	6ES7131-6BF00-0CA0	-30	+60 °C	FS 07	5,000
DI	DI 8x24VDC HF (PU* 10) ¹	6ES7131-6BF00-2CA0	-30	+60 °C	FS 07	5,000
DI	DI 8xNAMUR HF	6ES7131-6TF00-0CA0	-30	+60 °C	FS 04	5,000
DI	DI 8x24VDC HS	6ES7131-6BF00-0DA0	-30	+60 °C	FS 04	5,000
DI	DI 16x24VDC ST	6ES7131-6BH01-0BA0	-30	+60 °C	FS 02	5,000
DI	DI 16x24VDC ST (PU* 10) ¹	6ES7131-6BH01-2BA0	-30	+60 °C	FS 02	5,000
F-DI	F-DI 8x24VDC HF	6ES7136-6BA00-0CA0	0	+60 °C	FS 04	4,000
F-DI	F-DI 8x24VDC HF	6ES7136-6BA01-0CA0	0	+60 °C	FS 01	4,000

¹ Packaging unit: Pack of 10

Digital output modules

Type	Name	Article number	Ambient temperature			Maximum installation altitude above sea level [m]
			Lower limit [°C]	Upper limit [°C]	As of revision	
DQ	DQ 8x24VDC/0.5A BA	6ES7132-6BF01-0AA0	-30	+60 °C	FS 02	5,000
DQ	DQ 8x24VDC/0.5A BA (PU* 10) ¹	6ES7132-6BF01-2AA0	-30	+60 °C	FS 02	5,000
DQ	DQ 8x24VDC/0,5A SNK BA	6ES7132-6BF61-0AA0	-25	+60 °C	FS 02	5,000
DQ	DQ 4x24VDC/2A ST	6ES7132-6BD20-0BA0	-30	+60 °C	FS 08	5,000
DQ	DQ 4x24VDC/2A ST (PU* 10) ¹	6ES7132-6BD20-2BA0	-30	+60 °C	FS 08	5,000
DQ	DQ 4x24...230VAC/2A ST	6ES7132-6FD00-0BB1	-30	+60 °C	FS 05	3,000 (277 V AC)
DQ	DQ 4x24...230VAC/2A ST (PU* 10) ¹	6ES7132-6FD00-2BB1	-30	+60 °C	FS 05	3,000 (277 V AC)
DQ	DQ 4x24VDC/2A HF	6ES7132-6BD20-0CA0	-30	+60 °C	FS 06	5,000
DQ	DQ 4x24...230VAC/2A HF	6ES7132-6FD00-0CU0	-30	+60 °C	FS 04	3,000 (277 V AC)
DQ	DQ 4x24VDC/2A HS	6ES7132-6BD20-0DA0	-30	+60 °C	FS 05	5,000
DQ	DQ 16x24VDC/0.5A BA	6ES7132-6BH00-0AA0	-30	+60 °C	FS 03	5,000
DQ	DQ 16x24VDC/0.5A BA (PU* 10) ¹	6ES7132-6BH00-2AA0	-30	+60 °C	FS 03	5,000
DQ	DQ 8x24VDC/0.5A ST	6ES7132-6BF01-0BA0	-30	+60 °C	FS 02	5,000
DQ	DQ 8x24VDC/0.5A ST (PU* 10) ¹	6ES7132-6BF01-2BA0	-30	+60 °C	FS 02	5,000
DQ	DQ 8x24VDC/0.5A HF	6ES7132-6BF00-0CA0	-30	+60 °C	FS 07	5,000
DQ	DQ 8x24VDC/0.5A HF (PU* 10) ¹	6ES7132-6BF00-2CA0	-30	+60 °C	FS 07	5,000
DQ	DQ 16x24VDC/0.5A ST	6ES7132-6BH01-0BA0	-30	+60 °C	FS 03	5,000
DQ	DQ 16x24VDC/0.5A ST (PU* 10) ¹	6ES7132-6BH01-2BA0	-30	+60 °C	FS 03	5,000
F-DQ	F-DQ 4x24VDC/2A PM HF	6ES7136-6DB00-0CA0	0	+60 °C	FS 04	4,000
F-DQ	F-DQ 8x24VDC/0.5A PP HF	6ES7136-6DC00-0CA0	0	+60 °C	FS 01	4,000
RQ	RQ 4x24VUC/2A CO ST	6ES7132-6GD51-0BA0	-30	+60 °C	FS 02	2 000
RQ	RQ 4x120VDC-230VAC/5A NO ST	6ES7132-6HD01-0BB1	-30	+60 °C	FS 02	2 000
RQ	RQ 4x120VDC-230VAC/5A NO ST (PU* 10)	6ES7132-6HD01-2BB1	-30	+60 °C	FS 02	2 000
RQ	RQ 4x120VDC-230VAC/5A NO MA ST	6ES7132-6MD00-0BB1	-30	+60 °C	FS 03	2 000

¹ Packaging unit: Pack of 10

Using ET 200SP higher than 2 000 m above sea level.

3.2 Listing of the modules

Type	Name	Article number	Ambient temperature			Maximum installation altitude above sea level [m]
			Lower limit [°C]	Upper limit [°C]	As of revision	
RQ	RQ 3x120VDC-230VAC/5A CO ST	6ES7132-6HC50-0BU0	-30	+60 °C	FS 01	2 000
RQ	RQ 3x120VDC-230VAC/5A CO n.i. ST	6ES7132-6HC70-0BU0	-30	+60 °C	FS 01	2 000
F-RQ	F-RQ 1x24VDC/24...230VAC-5A ST	6ES7136-6RA00-0BF0	0	+60 °C	FS 01	2 000

¹ Packaging unit: Pack of 10

Analog modules

Type	Name	Article number	Ambient temperature			Maximum installation altitude above sea level [m]
			Lower limit [°C]	Upper limit [°C]	As of revision	
AI	AI 2xI 2/4-wire ST	6ES7134-6GB00-0BA1	-30	+60 °C	FS 04	5,000
AI	AI 2xU ST	6ES7134-6FB00-0BA1	-30	+60 °C	FS 04	5,000
AI	AI 2xU// 2/4-wire HF	6ES7134-6HB00-0CA1	-30	+60 °C	FS 06	5,000
AI	AI 2xU// 2-/4-wire HS	6ES7134-6HB00-0DA1	-30	+60 °C	FS 07	5,000
AI	AI 2x SG 4-/6-wire HS	7MH4134-6LB00-0DA0	-25	+60 °C	FS 01	3,000
AI	AI 4xI 2-wire 4...20mA HART HF	6ES7134-6TD00-0CA1	-30	+60 °C	FS 01	5,000
AI	AI 4xI 2-/4-wire ST	6ES7134-6GD01-0BA1	-30	+60 °C	FS 02	5,000
AI	AI 4xI 2-/4-wire ST (PU* 10) ¹	6ES7134-6GD01-2BA1	-30	+60 °C	FS 02	5,000
AI	AI 4xU// 2-wire ST	6ES7134-6HD01-0BA1	-30	+60 °C	FS 02	5,000
AI	AI 4xU// 2-wire ST (PU* 10) ¹	6ES7134-6HD01-2BA1	-30	+60 °C	FS 02	5,000
AI	AI 8xI 2/4-wire BA	6ES7134-6GF00-0AA1	-30	+60 °C	FS 04	5,000
AI	AI 8xU BA	6ES7134-6FF00-0AA1	-30	+60 °C	FS 04	5,000
AI	AI 4xTC HS	6ES7134-6JD00-0DA1	-30	+60 °C	FS 02	5,000
AI	AI 4xRTD/TC 2-/3-/4-wire HF	6ES7134-6JD00-0CA1	-30	+60 °C	FS 08	5,000
AI	AI 4xRTD/TC 2-/3-/4-wire HF (PU* 10) ¹	6ES7134-6JD00-2CA1	-30	+60 °C	FS 08	5,000
AI	AI 8xRTD/TC 2-wire HF	6ES7134-6JF00-0CA1	-30	+60 °C	FS 05	5,000
AI	AI 8xRTD/TC 2-wire HF (PU* 10) ¹	6ES7134-6JF00-2CA1	-30	+60 °C	FS 05	5,000
AI	AI Energy Meter 400V ST	6ES7134-6PA01-0BDO	0	+60 °C	FS 01	3,000

¹ Packaging unit: Pack of 10

² Installation altitude higher than 2 000 m on request

Type	Name	Article number	Ambient temperature			Maximum installation altitude above sea level [m]
			Lower limit [°C]	Upper limit [°C]	As of revision	
AI	AI Energy Meter 480V ST	6ES7134-6PA20-0BD0	0	+60 °C	FS 01	3,000
AI	AI Energy Meter HF CT	6ES7134-6PA00-0CU0	-30	+60 °C	FS 01	2000 ²
AI	AI Energy Meter HF RC	6ES7134-6PA20-0CU0	-30	+60 °C	FS 01	2000 ²
F-AI	F-AI 4XI (0)4..20mA HF	6ES7136-6AA00-0CA1	0	+60 °C	FS 01	4,000
F-AI	F-AI 4xU 0..10V HF	6ES7136-6AB00-0CA1	0	+60 °C	FS 01	4,000
AQ	AQ 2xI ST	6ES7135-6GB00-0BA1	-30	+60 °C	FS 03	5,000
AQ	AQ 2xU ST	6ES7135-6FB00-0BA1	-30	+60 °C	FS 03	5,000
AQ	AQ 2xU/I HF	6ES7135-6HB00-0CA1	-30	+60 °C	FS 04	5,000
AQ	AQ 2xU/I HS	6ES7135-6HB00-0DA1	-30	+60 °C	FS 06	5,000
AQ	AQ 4xU/I ST	6ES7135-6HD00-0BA1	-30	+60 °C	FS 07	5,000
AQ	AQ 4xI HART HF	6ES7135-6TD00-0CA1	-30	+60 °C	FS 01	5,000

¹ Packaging unit: Pack of 10

² Installation altitude higher than 2 000 m on request

Technology modules and communication modules

Type	Name	Article number	Ambient temperature			Maximum installation altitude above sea level [m]
			Lower limit [°C]	Upper limit [°C]	As of revision	
TM	TM Count 1x24V	6ES7138-6AA01-0BA0	-30	+60°C	FS 03	5,000
TM	TM Count 1x24V (PU* 10) ¹	6ES7138-6AA01-2BA0	-30	+60°C	FS 03	5,000
TM	TM PosInput 1	6ES7138-6BA01-0BA0	-30	+60°C	FS 03	5,000
TM	TM PosInput 1 (PU* 10) ¹	6ES7138-6BA01-2BA0	-30	+60°C	FS 03	5,000
TM	TM Timer DIQ 10x24V	6ES7138-6CG00-0BA0	-30	+60°C	FS 03	5,000
TM	TM Pulse 2x24V	6ES7138-6DB00-0BB1	-30	+60°C	FS 03	5,000
TM	TM PTO 2x24V	6ES7138-6EB00-0BA0	-30	+60°C	FS 00	5,000
TM	TM WP321 1x5VDC#1-4mV/V ST	7MH4138-6AA00-0BA0	-25	+60°C	FS 04	5,000
TM	TM WP351 HF	7MH4138-6BA00-0CU0	-30	+60°C	FS 01	5,000
TM	TM ECC PL ST	6FE1242-6TM20-0BB1	-30	+60°C	FS 00	2 000
TM	TM ECC 2xPWM ST	6FE1242-6TM10-0BB1	-30	+60°C	FS 00	2 000
TM	Pneumatic valve island Airline SP 8647	Bürkert	0	+55°C	-	2 000

¹ Packaging unit: Pack of 10

Using ET 200SP higher than 2 000 m above sea level.

3.2 Listing of the modules

Type	Name	Article number	Ambient temperature			Maximum installation altitude above sea level [m]
			Lower limit [°C]	Upper limit [°C]	As of revision	
TM	TM StepDrive 1x24..48V/5A*	phytron 10020273	0	+60°C	-	2 000
TM	TM SITRANS FCT070	7ME4138-6AA00-0BB1	-30	+60°C	FS 00	2 000
F-TM	F-TM ServoDrive 1x24..48V 5A ST	6BK1136-6AB00-0BU0	-30	+60°C	FS 00	3,000
CM	CM PtP	6ES7137-6AA00-0BA0	-30	+60°C	FS 03	5,000
CM	CM 1xDALI	6ES7137-6CA00-0BU0	-30	+60°C	FS 03	3,000
CM	CM 4xIO-Link	6ES7137-6BD00-0BA0	-30	+60°C	FS 03	2 000
CM	CM DP (für CPU)	6ES7545-5DA00-0AB0	-25	+60°C	FS 04	5,000
CM	CM AS-I MASTER ST (AS-I V3.0)	3RK7137-6SA00-0BC1	-25	+60°C	FS 20	2 000
CM	CM CAN	6ES7137-6EA00-0BA0	-30	+60°C	FS 03	5,000
F-CM	F-CM AS-I SAFETY ST	3RK7136-6SC00-0BC1	0	+60°C	FS 01	2 000
F-PM-E	F-PM-E 24VDC/8A PPM ST	6ES7136-6PA00-0BC0	0	+60°C	FS 05	4,000

¹ Packaging unit: Pack of 10

Motor starters and BaseUnits BU type P0

Type	Name	Article number	Ambient temperature			Maximum installation altitude above sea level [m]
			Lower limit [°C]	Upper limit [°C]	As of revision	
MS	DS 0.1 - 0.4A HF	3RK1308-0AA00-0CP0	-25	+60 °C	FS 01	4,000
MS	DS 0.3 - 1 A HF	3RK1308-0AB00-0CP0	-25	+60 °C	FS 01	4,000
MS	DS 0.9 - 3 A HF	3RK1308-0AC00-0CP0	-25	+60 °C	FS 01	4,000
MS	DS 2.8 - 9 A HF	3RK1308-0AD00-0CP0	-25	+60 °C	FS 01	4,000
MS	DS 4.0 - 12 A HF	3RK1308-0AE00-0CP0	-25	+60 °C	FS 01	4,000
MS	RS 0.1 - 0.4A HF	3RK1308-0BA00-0CP0	-25	+60 °C	FS 01	4,000
MS	RS 0.3 - 1 A HF	3RK1308-0BB00-0CP0	-25	+60 °C	FS 01	4,000
MS	RS 0.9 - 3 A HF	3RK1308-0BC00-0CP0	-25	+60 °C	FS 01	4,000
MS	RS 2.8 - 9 A HF	3RK1308-0BD00-0CP0	-25	+60 °C	FS 01	4,000
MS	RS 4.0 - 12 A HF	3RK1308-0BE00-0CP0	-25	+60 °C	FS 01	4,000
F-MS	F-DS 0.1 - 0.4A HF	3RK1308-0CA00-0CP0	-25	+60 °C	FS 01	4,000
F-MS	F-DS 0.3 - 1 A HF	3RK1308-0CB00-0CP0	-25	+60 °C	FS 01	4,000
F-MS	F-DS 0.9 - 3 A HF	3RK1308-0CC00-0CP0	-25	+60 °C	FS 01	4,000
F-MS	F-DS 2.8 - 9 A HF	3RK1308-0CD00-0CP0	-25	+60 °C	FS 01	4,000

Type	Name	Article number	Ambient temperature			Maximum installation altitude above sea level [m]
			Lower limit [°C]	Upper limit [°C]	As of revision	
F-MS	F-DS 4.0 - 12 A HF	3RK1308-OCE00-OCPO	-25	+60 °C	FS 01	4,000
F-MS	F-RS 0.1 - 0.4A HF	3RK1308-ODA00-OCPO	-25	+60 °C	FS 01	4,000
F-MS	F-RS 0.3 - 1 A HF	3RK1308-ODB00-OCPO	-25	+60 °C	FS 01	4,000
F-MS	F-RS 0.9 - 3 A HF	3RK1308-ODC00-OCPO	-25	+60 °C	FS 01	4,000
F-MS	F-RS 2.8 - 9 A HF	3RK1308-ODD00-OCPO	-25	+60 °C	FS 01	4,000
F-MS	F-RS 4.0 - 12 A HF	3RK1308-ODE00-OCPO	-25	+60 °C	FS 01	4,000
BU type P0	BU30-MS1	3RK1908-OAP00-OAPO	-25	+60 °C	FS 01	4,000
BU type P0	BU30-MS3	3RK1908-OAP00-OBPO	-25	+60 °C	FS 01	4,000
BU type P0	BU30-MS2	3RK1908-OAP00-OCPO	-25	+60 °C	FS 01	4,000
BU type P0	BU30-MS4	3RK1908-OAP00-ODPO	-25	+60 °C	FS 01	4,000
BU type P0	BU30-MS5	3RK1908-OAP00-OEPO	-25	+60 °C	FS 01	2 000
BU type P0	BU30-MS6	3RK1908-OAP00-OFPO	-25	+60 °C	FS 01	2 000
BU type P0	BU30-MS7	3RK1908-OAP00-OGPO	-25	+60 °C	FS 01	2 000
BU type P0	BU30-MS8	3RK1908-OAP00-OHPO	-25	+60 °C	FS 01	2 000
BU type P0	BU30-MS9	3RK1908-OAP00-OJPO	-25	+60 °C	FS 01	2 000
BU type P0	BU30-MS10	3RK1908-OAP00-OKPO	-25	+60 °C	FS 01	2 000

BaseUnits BU type A0 and A1

Type	Name	Article number	Ambient temperature			Maximum installation altitude above sea level [m]
			Lower limit [°C]	Upper limit [°C]	As of revision	
BU type A0	BU15-P16+A0+2B	6ES7193-6BP00-0BA0	-30	+60 °C	FS 06	5,000
BU type A0	BU15-P16+A0+2B (PU* 10) ¹	6ES7193-6BP00-2BA0	-30	+60 °C	FS 06	5,000
BU type A0	BU15-P16+A0+2D	6ES7193-6BP00-0DA0	-30	+60 °C	FS 06	5,000
BU type A0	BU15-P16+A0+2D (PU* 10) ¹	6ES7193-6BP00-2DA0	-30	+60 °C	FS 06	5,000
BU type A0	BU15 double BU+2B	6ES7193-6BP60-0BA0	-30	+60 °C	FS 03	5,000
BU type A0	BU15 double BU+2DB	6ES7193-6BP60-0DA0	-30	+60 °C	FS 03	5,000
BU type A0	BU15-P16+A10+2B	6ES7193-6BP20-0BA0	-30	+60 °C	FS 06	5,000
BU type A0	BU15-P16+A10+2B (PU* 10) ¹	6ES7193-6BP20-2BA0	-30	+60 °C	FS 06	5,000
BU type A0	BU15-P16+A10+2D	6ES7193-6BP20-0DA0	-30	+60 °C	FS 07	5,000

¹ Packaging unit: Pack of 10

Using ET 200SP higher than 2 000 m above sea level.

3.2 Listing of the modules

Type	Name	Article number	Ambient temperature			Maximum installation altitude above sea level [m]
			Lower limit [°C]	Upper limit [°C]	As of revision	
BU type A0	BU15-P16+A10+2D (PU* 10) ¹	6ES7193-6BP20-2DA0	-30	+60 °C	FS 07	5,000
BU type A1	BU15-P16+A0+2B/T	6ES7193-6BP00-0BA1	-30	+60 °C	FS 06	5,000
BU type A1	BU15-P16+A0+2D/T	6ES7193-6BP00-0DA1	-30	+60 °C	FS 06	5,000
BU type A1	BU15-P16+A0+12B/T	6ES7193-6BP40-0BA1	-30	+60 °C	FS 06	5,000
BU type A1	BU15-P16+A0+12D/T	6ES7193-6BP40-0DA1	-30	+60 °C	FS 07	5,000

¹ Packaging unit: Pack of 10

BaseUnits BU type B0 bis U0

Type	Name	Article number	Ambient temperature			Maximum installation altitude above sea level [m]
			Lower limit [°C]	Upper limit [°C]	As of revision	
BU type B0	BU20-P12+A4+0B	6ES7193-6BP20-0BB0	-30	+60 °C	FS 04	5,000 (SELV/PELV supplied) 3,000 (277 V AC)
BU type B0	BU20-P12+A4+0B (PU* 10) ¹	6ES7193-6BP20-2BB0	-30	+60 °C	FS 04	5,000 (SELV/PELV supplied) 3,000 (277 V AC)
BU type B1	BU20-P12+A0+4B	6ES7193-6BP20-0BB1	-30	+60 °C	FS 04	5,000 (SELV/PELV supplied) 3,000 (277 V AC)
BU type B1	BU20-P12+A0+4B (PU* 10) ¹	6ES7193-6BP20-2BB1	-30	+60 °C	FS 04	5,000 (SELV/PELV supplied) 3,000 (277 V AC)
BU type C0	BU20-P6+A2+4D	6ES7193-6BP20-0DC0	-30	+60 °C	FS 03	5,000 (SELV/PELV supplied)
BU type C1	BU20-P6+A2+4B	6ES7193-6BP20-0BC1	-30	+60 °C	FS 03	5,000 (SELV/PELV supplied)

¹ Packaging unit: Pack of 10

Type	Name	Article number	Ambient temperature			Maximum installation altitude above sea level [m]
			Lower limit [°C]	Upper limit [°C]	As of revision	
BU type D0	BU20-P12+A0+0B	6ES7193-6BP00-0BD0	-30	+60 °C	FS 04	5,000 (SELV/PELV supplied) 3,000 (277 V AC)
BU type E0	BaseUnit BU-SEND	6ES7193-6BN00-0NE0	-30	+60 °C	FS 04	2 000
BU type F0	BU20-P8+A4+0B	6ES7193-6BP20-0BF0	-30	+60 °C	FS 04	2 000
BU type U0	BU20-P16+A0+2B	6ES7193-6BP00-0BU0	-30	+60 °C	FS 03	5,000 (SELV/PELV supplied) 3,000 (277 V AC)
BU type U0	BU20-P16+A0+2B (PU* 10) ¹	6ES7193-6BP00-2BU0	-30	+60 °C	FS 03	5,000 (SELV/PELV supplied) 3,000 (277 V AC)
BU type U0	BU20-P16+A0+2D	6ES7193-6BP00-0DU0	-30	+60 °C	FS 03	5,000 (SELV/PELV supplied) 3,000 (277 V AC)
BU type U0	BU20-P16+A0+2D (PU* 10) ¹	6ES7193-6BP00-2DU0	-30	+60 °C	FS 03	5,000 (SELV/PELV supplied) 3,000 (277 V AC)

¹ Packaging unit: Pack of 10

Potential distributor

Type	Name	Article number	Ambient temperature			Maximum installation altitude above sea level [m]
			Lower limit [°C]	Upper limit [°C]	As of revision	
PotDis	PotDis-BU-P1/D-R	6ES7193-6UP00-0DP1	-30	+60 °C	FS 04	5,000
PotDis	PotDis-BU-P1/B-R	6ES7193-6UP00-0BP1	-30	+60 °C	FS 04	5,000
PotDis	PotDis-BU-P2/D-B	6ES7193-6UP00-0DP2	-30	+60 °C	FS 04	5,000
PotDis	PotDis-BU-P2/B-B	6ES7193-6UP00-0BP2	-30	+60 °C	FS 04	5,000
PotDis	PotDis TB P1-R	6ES7193-6TP00-0TP1	-30	+60 °C	FS 03	5,000

¹ Packaging unit: Pack of 5

3.3 Restrictions

Type	Name	Article number	Ambient temperature			Maximum installation altitude above sea level [m]
			Lower limit [°C]	Upper limit [°C]	As of revision	
PotDis	PotDis TB P2-B	6ES7193-6TP00-0TP2	-30	+60 °C	FS 03	5,000
PotDis	PotDis TB BR-W	6ES7193-6TP00-0TP0	-30	+60 °C	FS 03	5,000
PotDis	PotDis TB n.c.-G	6ES7193-6TP00-0TN0	-30	+60 °C	FS 03	5,000
BU cover	BU cover - 15 mm (PU* 5) ¹	6ES7133-6CV15-1AM0	-40	+60 °C	FS 01	5,000
BU cover	BU cover - 20 mm (PU* 5) ¹	6ES7133-6CV20-1AM0	-40	+60 °C	FS 01	5,000

¹ Packaging unit: Pack of 5

3.3 Restrictions

Restrictions of the max. ambient temperature specified with regard to the installation altitude

Installation altitude	Derating factor for ambient temperature ¹⁾
-1 000 to 2 000 m	1.0
2 000 to 3 000 m	0.9
3 000 to 4 000 m	0.8
4 000 to 5 000 m	0.7

¹⁾ Base value for the application of the derating factor is the maximum permissible ambient temperature in °C for 2 000 m

NOTE

- Linear interpolation between altitudes is permissible.
- The derating factors compensate for the decreasing cooling effect of air at higher altitudes due to lower density.
- Note the mounting position of the respective module in the technical specifications. The basis is the standard IEC 61131-2:2017.
- Make sure that the power supplies you use are also rated for altitudes > 2 000 m.
- The "Safety-related shutdown of standard modules" function, as described in the Internet (<https://support.industry.siemens.com/cs/ww/en/view/39198632>), is only approved up to a maximum of 2 000 m.