

## SITOP Power Supply

### SITOP UPS1600 Firmware V2.3: Faceplates and Communication Blocks V3.0 for SIMATIC STEP7

Function Manual

<u>Warranty and liability</u>	<b>1</b>
<u>Preface</u>	<b>2</b>
<u>Task</u>	<b>3</b>
<u>Structure</u>	<b>4</b>
<u>Function blocks</u>	<b>5</b>
<u>Faceplates</u>	<b>6</b>
<u>Application of the function blocks</u>	<b>7</b>
<u>Application of the faceplates</u>	<b>8</b>

## Legal information

### Warning notice system

This manual contains notices you have to observe in order to ensure your personal safety, as well as to prevent damage to property. The notices referring to your personal safety are highlighted in the manual by a safety alert symbol, notices referring only to property damage have no safety alert symbol. These notices shown below are graded according to the degree of danger.

<b>⚠ DANGER</b>
indicates that death or severe personal injury <b>will</b> result if proper precautions are not taken.
<b>⚠ WARNING</b>
indicates that death or severe personal injury <b>may</b> result if proper precautions are not taken.
<b>⚠ CAUTION</b>
indicates that minor personal injury can result if proper precautions are not taken.
<b>NOTICE</b>
indicates that property damage can result if proper precautions are not taken.

If more than one degree of danger is present, the warning notice representing the highest degree of danger will be used. A notice warning of injury to persons with a safety alert symbol may also include a warning relating to property damage.

### Qualified Personnel

The product/system described in this documentation may be operated only by **personnel qualified** for the specific task in accordance with the relevant documentation, in particular its warning notices and safety instructions. Qualified personnel are those who, based on their training and experience, are capable of identifying risks and avoiding potential hazards when working with these products/systems.

### Proper use of Siemens products

Note the following:

<b>⚠ WARNING</b>
Siemens products may only be used for the applications described in the catalog and in the relevant technical documentation. If products and components from other manufacturers are used, these must be recommended or approved by Siemens. Proper transport, storage, installation, assembly, commissioning, operation and maintenance are required to ensure that the products operate safely and without any problems. The permissible ambient conditions must be complied with. The information in the relevant documentation must be observed.

### Trademarks

All names identified by ® are registered trademarks of Siemens AG. The remaining trademarks in this publication may be trademarks whose use by third parties for their own purposes could violate the rights of the owner.

### Disclaimer of Liability

We have reviewed the contents of this publication to ensure consistency with the hardware and software described. Since variance cannot be precluded entirely, we cannot guarantee full consistency. However, the information in this publication is reviewed regularly and any necessary corrections are included in subsequent editions.

# Table of contents

<b>1</b>	<b>Warranty and liability</b> .....	<b>5</b>
1.1	Security information .....	6
<b>2</b>	<b>Preface</b> .....	<b>7</b>
<b>3</b>	<b>Task</b> .....	<b>9</b>
<b>4</b>	<b>Structure</b> .....	<b>11</b>
4.1	Solution overview .....	11
4.2	Description of the core functionality .....	14
4.3	Hardware and software components used .....	15
<b>5</b>	<b>Function blocks</b> .....	<b>17</b>
5.1	Function and task of the function blocks.....	17
5.2	Operating conditions .....	20
<b>6</b>	<b>Faceplates</b> .....	<b>21</b>
6.1	Description .....	21
6.2	State.....	22
6.3	Information .....	24
6.4	Trends .....	25
6.5	Alarms .....	26
<b>7</b>	<b>Application of the function blocks</b> .....	<b>27</b>
7.1	Application of the function blocks in SIMATIC STEP 7 V5.6.....	27
7.1.1	Prerequisites .....	27
7.1.2	Content of the library for SIMATIC STEP 7 V5.6.....	28
7.1.3	Interfaces of the function block .....	31
7.1.4	LUPS1600_typeUPS1600Data (UDT1) .....	34
7.1.5	Integrating the function block .....	35
7.2	Application of the function blocks under STEP 7 Professional V15.1 .....	48
7.2.1	Prerequisites .....	48
7.2.2	Content of the library for STEP 7 V15.1 .....	49
7.2.3	Interfaces of the function block FB165 .....	51
7.2.4	LUPS1600_typeUPS1600Data .....	55
7.2.5	Integrating the function block .....	56
7.2.5.1	Procedure when using an S7-300/400 .....	56
7.2.5.2	Procedure when using an S7-1200/1500 .....	63

<b>8</b>	<b>Application of the faceplates .....</b>	<b>69</b>
8.1	Application of the faceplates in WinCC flexible 2008 .....	69
8.1.1	Prerequisites .....	69
8.1.2	Library for WinCC flexible .....	70
8.1.3	Integrating the faceplates.....	70
8.2	Application of screen windows in WinCC V7.4 .....	85
8.2.1	Prerequisites .....	85
8.2.2	Library for WinCC V7.4 .....	86
8.2.3	Integrating the screen windows .....	87
8.2.4	Application of screen windows in WinCC V7.5 .....	93
8.2.4.1	Overview .....	93
8.3	Application of faceplates in WinCC Comfort/Advanced V15.1 .....	94
8.3.1	Prerequisites .....	94
8.3.2	Library for WinCC Comfort/Advanced .....	95
8.3.3	Integrating the faceplates.....	95
8.4	Application of screen windows in WinCC Professional V15.1 .....	112
8.4.1	Prerequisites .....	112
8.4.2	Library for WinCC Professional.....	113
8.4.3	Integrating the screen windows .....	113



## Warranty and liability

---

### Note

The application examples are not binding and do not claim to be complete with regard to configuration, equipment or any contingencies. The application examples do not represent customer-specific solutions. They are only intended to provide support for typical applications, you are responsible for the correct operation of the described products. These application examples do not relieve you from responsibilities of using, installing, operating and servicing the equipment safely and professionally. When using these application examples, you recognize that we are not liable for any damage/claims beyond the liability clauses described.

We reserve the right to make changes to these application examples at any time and without prior notice. If there are any deviations in the recommendations provided in this application example and other Siemens publications, for example catalogs, the contents of the other documents shall have priority.

---

We do not accept any liability for the information contained in this document. Any claims against us – based on whatever legal reason – resulting from the use of the examples, information, programs, engineering and performance data etc., described in this application example shall be excluded. Such an exclusion shall not apply in the case of mandatory liability, for example under the German Product Liability Act ("Produkthaftungsgesetz"), in case of intent, gross negligence, or injury of life, body or health, guarantee for the quality of a product, fraudulent concealment of a deficiency or breach of fundamental contractual obligations ("wesentliche Vertragspflichten").

The compensation for damages due to a breach of a fundamental contractual obligation is, however, limited to the foreseeable damage, typical for the type of contract, except in the event of intent or gross negligence or injury to life, body or health. The above provisions do not imply a change of the burden of proof to your detriment. Any form of duplication or distribution of these application examples or excerpts hereof is prohibited without the expressed consent of Siemens AG.

## 1.1 Security information

Siemens provides products and solutions with industrial security functions that support the secure operation of plants, systems, machines and networks.

In order to protect plants, systems, machines and networks against cyber threats, it is necessary to implement – and continuously maintain – a holistic, state-of-the-art industrial security concept. Siemens' products and solutions constitute one element of such a concept.

Customers are responsible for preventing unauthorized access to their plants, systems, machines and networks. Such systems, machines and components should only be connected to an enterprise network or the internet if and to the extent such a connection is necessary and only when appropriate security measures (e.g. firewalls and/or network segmentation) are in place.

For additional information on industrial security measures that may be implemented, please visit

<https://www.siemens.com/industrialsecurity>.

Siemens' products and solutions undergo continuous development to make them more secure. Siemens strongly recommends that product updates are applied as soon as they are available and that the latest product versions are used. Use of product versions that are no longer supported, and failure to apply the latest updates may increase customer's exposure to cyber threats.

To stay informed about product updates, subscribe to the Siemens Industrial Security RSS Feed under

<https://www.siemens.com/industrialsecurity>.

# Preface

## Purpose of this document

This document describes LUPS1600 Block Library for SIMATIC STEP 7 V5.6, STEP 7 Professional V15.1, STEP 7 Professional V16, WinCC Flexible, WinCC V7.4, WinCC V7.5, WinCC Comfort/Advanced V15.1, WinCC Comfort/Advanced V16, WinCC Professional V15.1 and WinCC Professional V16. The block library provides tested code with clearly defined interfaces. You can use it as the basis for the task you wish to realize.

The main focus of this document is to describe:

- All Function Blocks (FB) pertaining to the block library.
- The functionality implemented through these blocks.

The documentation furthermore illustrates the possible operating conditions and applications of the block library for SIMATIC STEP 7 V5.6, STEP 7 Professional V15.1, STEP 7 Professional V16, WinCC Flexible, WinCC V7.4, WinCC V7.5, WinCC Comfort/Advanced V15.1, WinCC Comfort/Advanced V16, WinCC Professional V15.1 and WinCC Professional V16.

## References

For more information on SITOP UPS1600 manuals and related documentation, refer the following links:

- Siemens Industry Online Support (<https://support.industry.siemens.com/cs/start?lc=en-US>)
- SITOP UPS1600 Manual (<https://support.industry.siemens.com/cs/ww/en/view/84977415>)
- SIMATIC STEP 7 Basic/Professional V15.1 and SIMATIC WinCC V15.1 System Manual (<https://support.industry.siemens.com/cs/ww/en/view/109755202>)
- SIMATIC STEP 7 Basic/Professional V16 and SIMATIC WinCC V16 System Manual (<https://support.industry.siemens.com/cs/ww/en/view/109773506>)
- SIMATIC Programming with SIMATIC STEP 7 V5.5 (<https://support.industry.siemens.com/cs/ww/en/view/45531107>)
- WinCC flexible 2008 System Manual (<https://support.industry.siemens.com/cs/ww/en/view/18796010>)
- WinCC 7.4 System Manual (<https://support.industry.siemens.com/cs/ww/en/view/109736220>)
- WinCC 7.5 System Manual (<https://support.industry.siemens.com/cs/ww/en/view/109760739>)
- GSD for SITOP UPS1600 for integration into SIMATIC STEP 7 V5.6 (<https://support.industry.siemens.com/cs/ww/en/view/75854605>)
- Support Packages for the hardware catalog in the TIA Portal (HSP) (<https://support.industry.siemens.com/cs/ww/en/view/72341852>)

## Task

### Overview of the automation task

The figure below provides an overview of the automation task:

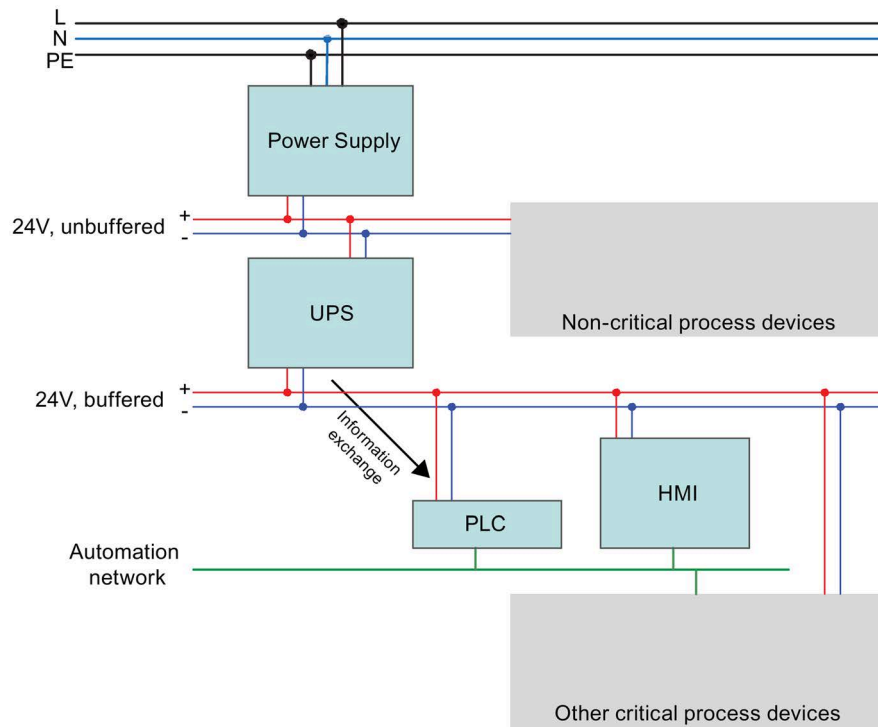

#### Legend

- L: Phase
- N: Neutral
- PE: Protective earth/ground
- Profinet

Figure 3-1

## **Task Description**

Your task is to equip the automation plant with Uninterruptible Power Supply (UPS). In the event of a power failure, critical process participants are to be protected.

In the event of a power failure of the automation plant, process values are to be maintained and plant components be safeguarded against mechanical damage by means of a defined stopping process.

UPS is integrated into the automation network via PROFINET.

The status and diagnostic information of the UPS is displayed in the individual Human Machine Interfaces (HMI) stations.

## Structure

### 4.1 Solution overview

#### Structure

The figure below shows a schematic overview of the most important components of the solution:

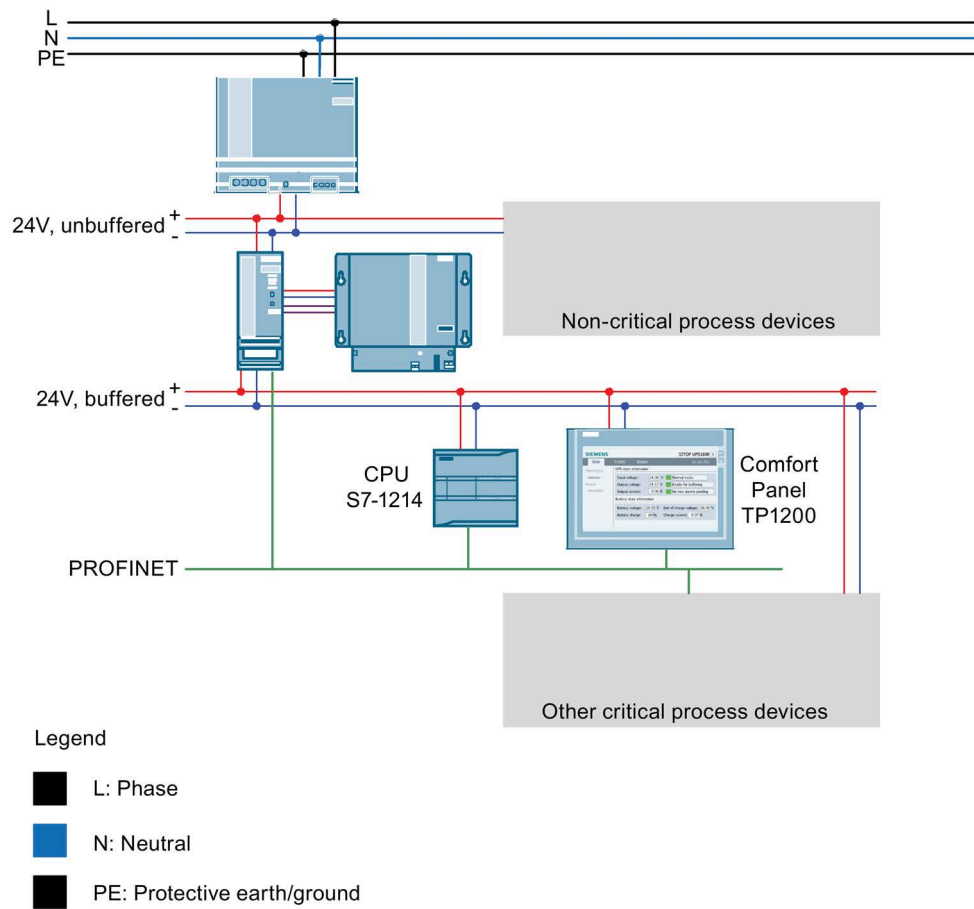

Figure 4-1

**Scope of this application example**

This application example provides FB1 function block for communication between the controller and SITOP UPS1600.

It also provides faceplates and screen windows for monitoring and operation.

**Note**

SITOP UPS1600 is termed as UPS1600 throughout this document.

**Function of the hardware components**

The table below describes the function of the Hardware (HW) components used in figure 4-1:

Name	Function
SITOP Power Supply	Central 24 V power supply for all process devices.
Non-critical process devices	Symbol for other non-critical process devices. (Devices that can be switched off when there is sufficient pressure, for example: compressors.)
SITOP UPS1600 and SITOP UPS1100	UPS with buffer (example, battery module).
S7-1214	Automation controller
Comfort Panel TP1200	Control panel for process visualization.
Other critical process devices	Symbol for other critical process devices.
PROFINET	Central process bus of all automation devices.

**Advantages**

This application offers the following advantages:

- Time and cost saving by means of FB1, HMI faceplates and screen windows.
- Easy and comprehensive introduction to integrating UPS1600 within a PROFINET network.

**Scope**

This application does not include description of:

- Creating program blocks in SIMATIC STEP 7 V5.6/STEP 7 Professional V15.1.
- Creating screens and objects in WinCC flexible/WinCC TIA Portal/WinCC.
- Configuring communication between the described terminal devices.
- Handling all the described SIMATIC terminal devices.



## Assumed knowledge

The user is assumed to have knowledge on the mentioned points:

- Using SIMATIC STEP 7 V5.6, STEP 7 Professional V15.1, STEP 7 Professional V16, WinCC flexible, WinCC V7.4, WinCC V7.5, WinCC Flexible 2008 SP5, WinCC Comfort/Advanced V15.1, WinCC Comfort/Advanced V16, and WinCC TIA Portal.
- Operating, handling, and configuring SIMATIC S7 controllers (S7-300/400 and S7-1200/1500).
- Operating, handling, and configuring HMI control panels (Multi Panels, Comfort Panels) and Runtime systems (WinCC flexible Runtime, WinCC Runtime Advanced, WinCC Runtime, WinCC Runtime Professional).
- Handling and operating SITOP UPS1600.

## 4.2 Description of the core functionality

### Sequence of the core functionality

Communication between UPS1600 and controller runs via PROFINET. The UPS1600 is connected to the controller as PROFINET IO node. Thus, the entire UPS1600 information (voltage, power, possible buffer time, battery state) is available in the controller.

In this application example, two scenarios are realized.

- The Programmable Logic Controller (PLC) via the supplied program block FB1 recognizes power failure. The information is made permanently available in the control program which can be then evaluated. This allows your process to respond and switch off your process devices in a defined manner.
- The Programmable Logic Controller (PLC) via the supplied program block FB2 recognizes diagnostic interrupts and generates alarm messages to WinCC.
- With the provided faceplates and screen windows, relevant information and important parameters are displayed on the HMI control panel.

---

#### Note

FB2 is applicable only to SIMATIC STEP7 V5.6.

---

### Overview and description of the user interface

The application example provides the following views in the faceplate:

- UPS state
- General Device information
- Output Data
- Voltage and power trend curves
- Currently pending alarms/alarm history

## 4.3 Hardware and software components used

### Hardware components

Component	No.	Article number	Note
SITOP UPS1600 20 A	1	6EP4136-3AB00-2AY0	Alternatively, SITOP UPS1600 10 A 6EP4134-3AB00-2AY0 or SITOP UPS1600 40 A 6EP4137-3AB00-2AY0 is used.
MP277 8" Touch	1	6AV6643-0CB01-1AX5	Refer to Requirements (Page 69).
Comfort Panel TP900	1	6AV2124-0JC01-0AX0	Refer to Requirements (Page 94).
CPU 1214C DC/DC/RLY PN/DP	1	6ES7214-1HG40-0XB0	Or other S7-1200/1500 CPU
CPU 315-2 PN/DP	1	6ES7315-2EH14-0AB0	Or other S7-300 CPU
SITOP UPS1100 3.2 Ah (Battery module)	1	6EP4133-0GB00-0AY0	

#### Note

The UPS1600 is upgraded with Firmware (FW) version 2.1 or higher.

### Standard software components

Component	No.	Article number	Note
WinCC Flexible 2008 SP5 Advanced	1	6AV6613-0AA51-3CA5	Alternatively, WinCC flexible 2008 SP5 Standard
WinCC Advanced V15.1	1	6AV2102-4AA03-0AE5	Alternatively, WinCC Comfort V15.1
STEP 7 Professional V5.6	1	6ES7810-4CC10-0YA5	-
STEP 7 Professional V15.1	1	6ES7822-1AA03-2YA6	-
WinCC Professional V15.1	1	6AV2103-0DA03-0AA5	-
WinCC V7.4	1	6AV6381-2BD07-3AH0	-

**Sample files and projects**

The following list in the table includes all files and projects that are used in this example:

Component	Note
LUPS1600	This folder contains the library for TIA Portal V15.1 and master copies for STEP 7 V15.1 and WinCC V15.1.
SITOP-UPS1600_Library_STEP7-V5_V3-0.7z	This folder contains the following subfolders. <ul style="list-style-type: none"> <li>• UPS1600 V3-0 STEP7 V5.6</li> <li>• UPS1600 V3-0 library WinCC flexible 2008</li> <li>• UPS1600 V3-0 library WinCC V7.4</li> <li>• UPS1600 V3-0 library WinCC V7.5</li> </ul>
UPS1600 V3-0 STEP7 V5.6	This folder contains the library of the function blocks (FB) for SIMATIC STEP 7 V5.6.
UPS1600 V3-0 library WinCC flexible 2008	This folder contains the library of the faceplates for WinCC flexible 2008 SP5.
UPS1600 V3-0 library WinCC V7.4	This folder contains the library of the screen windows for WinCC V7.4.
UPS1600 V3-0 library WinCC V7.5	This folder contains the library of the screen windows for WinCC V7.5.

# Function blocks

## 5.1 Function and task of the function blocks

### Overview

This chapter describes the application and requirements of FB1 and FB2 and its integration into a SIMATIC STEP 7 project.

### Task description and application

- In the event of a plant power failure, it is essential to safeguard certain machine components against damage and to back-up process relevant data in order to prevent data loss. The application of FB1 provides the option to bring your plant into a safe state and switch it off in a program-controlled manner while UPS1600 buffers the voltage.
- The Programmable Logic Controller (PLC) via the supplied program block FB2 recognizes diagnostic interrupts and generates alarm messages to WinCC.

### FB1 Function description

The FB1 cyclically monitors the operating mode of the UPS1600. When UPS1600 is in buffer mode, a 10 s timer within the FB starts. This timer prevents the plant from being brought into a safe state in the event of just a short voltage dip/drop. If the UPS is still in buffer mode after expiry of the timer, the parameter `UPSReadyForReset` is set from FALSE to TRUE. Further, this parameter is also used to bring the plant components into a safe state (maintenance mode). When the plant is brought into a safe state, the parameter `UPSExecuteReset` is set from FALSE to TRUE. The FB1 then sends a command to the UPS1600, which then switches off autonomously. The following flow diagram displays the program sequence of the FB1.

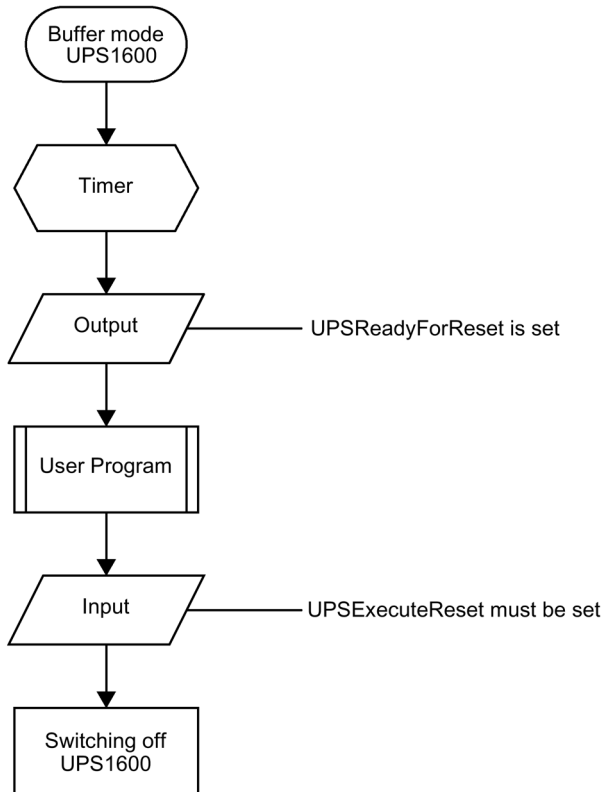

Figure 5-1

**Notes regarding the FB1**

- If the UPS1600 returns to the normal mode when the timer is running, the parameter `UPSReadyForReset` is not set.  
The timer is then reset.
- After the parameter `UPSExecuteReset` is set, the further program sequence is executed until UPS1600 is switched off via the FB1.
- The buffer time of UPS1600 must be set such that there is sufficient time to bring the plant into a safe state and switch off the UPS via the FB1.

**Notes regarding the FB2**

- In Report system error system diagnostics blocks, alarm messages will not include extended error information. So in order to show detailed message of interrupt, FB2 is developed. If we use this block, no need to generate system diagnostic blocks using RSE (Report system error).

## 5.2 Operating conditions

### Configuration

- FB1 and FB2 are approved for SIMATIC STEP 7 V5.6 and application of a CPU 300/400
- FB165 is approved for STEP 7 V15.1/STEP 7 Professional V15.1, STEP 7 V16/STEP 7 Professional V16 and application of a CPU 300/400 or CPU 1200/1500



# Faceplates

The HMI faceplate displays actual values and various states of the UPS1600 on WinCC Comfort/Advanced V15.1 and WinCC Professional V15.1.

## 6.1 Description

### Overview

This faceplate visualizes parameters of UPS1600 on an HMI control panel:



SIEMENS		SITOP UPS1600	
State	Information	Trends	Alarms
dc-ups-20a			
<b>UPS</b>			
Normal mode		Input voltage:	23.92V
Ready for buffering		Output voltage:	23.84V
		Output current:	0.00A
<b>Battery</b>			
Battery charge:	100%	Battery voltage:	25.29V
Battery charge current:	0.00A	End of charge voltage:	27.30V

Figure 6-1

The parameters of UPS1600 are distributed over four tabs in the faceplate, clicking on the relevant tab displays specific information. The four tabs are:

- State
- Information
- Trends
- Alarms

The contents of the tabs and the parameters are described in detail in the following sections.

## 6.2 State

This menu item displays the operating state and battery state of UPS1600:

The following table shows all parameters displayed under this menu with its corresponding display names:

Display name	Parameter of the UPS
Normal mode/Buffer mode	bufferMode
Ready for buffering/Not ready for buffering	readyForBuffering
Input voltage	inputVolt
Output voltage	outputVolt
Output current	outputCur
Battery charge	batteryChargeLevel
Battery voltage	batteryVolt
Battery Charge current	measuredChargeCur
End-of-charge voltage	endOfChargeVolt

The values of the parameters `bufferMode` and `readyForBuffering` are output via symbolic I/O fields. This has an indicator which is subject to the color dynamization and is dependent on the parameter value.

The following table shows the possible parameter states with its corresponding color dynamization:

Parameter	State/display name	Color
Normal mode	Normal mode	Green
	Buffer mode	Yellow
	Off	White
Ready for buffering	Ready for buffering	Green
	Not ready for buffering	Red
	Off	White

---

**Note**

All the I/O fields in the faceplate are read only values.

---

### 6.3 Information

This menu displays general device information about UPS1600:

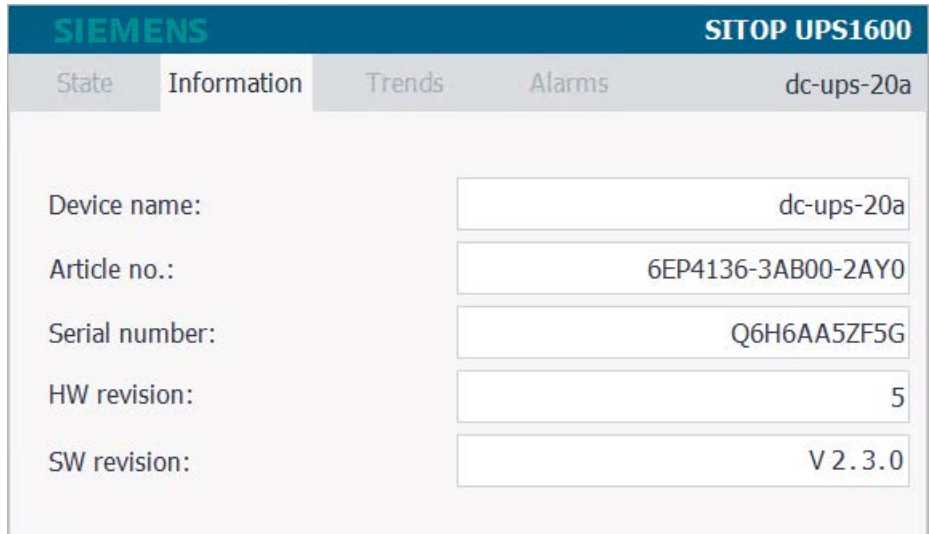

Figure 6-2

The following table shows all parameters displayed under this menu with its corresponding display names:

Table 6- 1

Display name	Parameter of the UPS
Device name	deviceName
Article no.	orderNumber
Serial number	serialNumber
HW revision	deviceHwRevision
SW revision	deviceSwRevision1, deviceSwRevision2, and deviceSwRevision3

## 6.4 Trends

### Description

The "Trends" tab displays the following attributes of UPS1600 in trend curves:

- UPS Input voltage
- UPS Output voltage
- UPS Output current
- Battery voltage
- Battery charge current

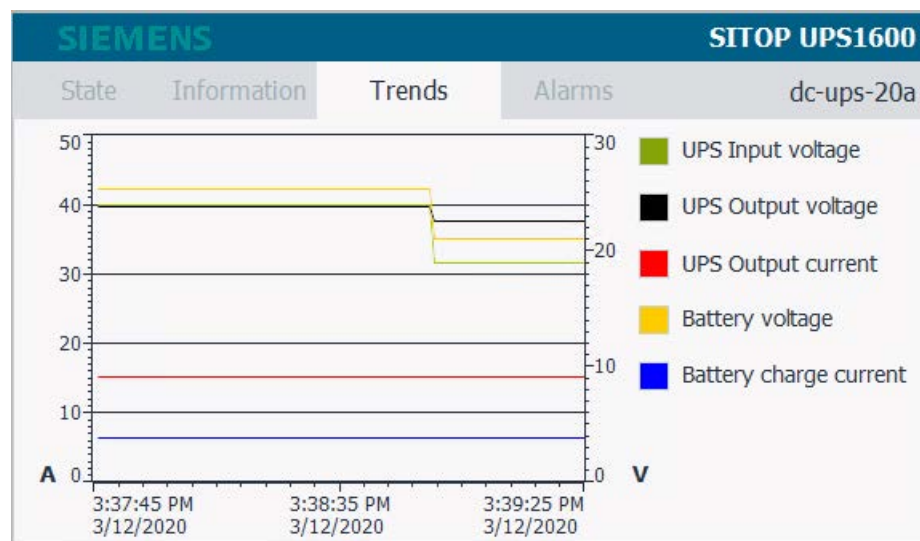

Figure 6-3

The time range of the X axis of the trend curve is 100 seconds. The trend variables used have an acquisition cycle of 1 second and are refreshed cyclically.

The table below describes UPS1600 parameters with their respective display names, color and unit representation:

Table 6- 2

Display name	Parameter of the UPS	Color	Unit
UPS Input voltage	inputVolt	Green	V
UPS Output voltage	outputVolt	Black	V
UPS Output current	outputCur	Red	A
Battery voltage	batteryVolt	Yellow	V
Battery charge current	measuredChargeCur	Blue	A

## 6.5 Alarms

### Description

The "Alarms" tab displays PROFINET diagnostic messages of SITOP UPS1600:

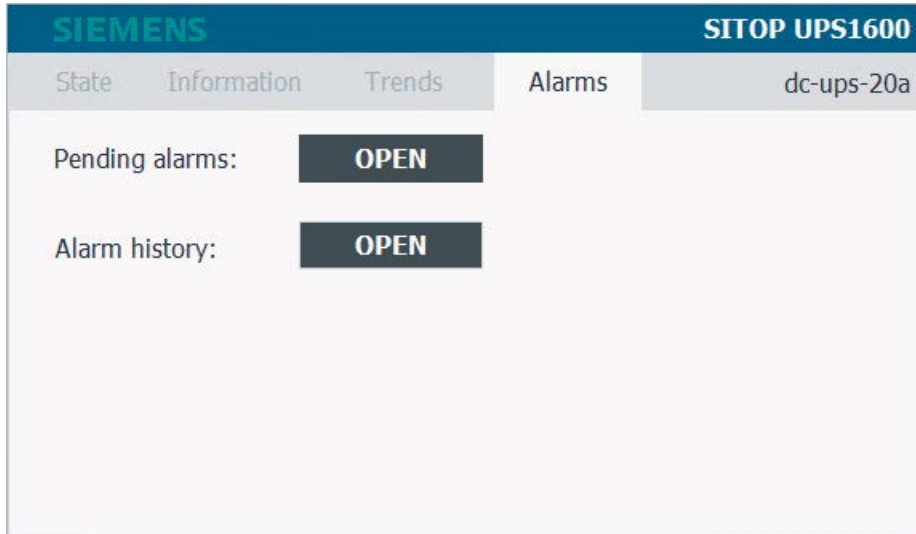

Figure 6-4

When you click on "OPEN" for Pending alarms and Alarm history buttons, two separate message windows open.

The message window for "Pending alarms" displays all currently pending PROFINET diagnostic messages of the UPS1600. The message window for "Alarm history" displays all PROFINET diagnostic messages of UPS1600 stored in the internal message buffer of the HMI control panel used.

### Prerequisites for displaying the PROFINET diagnostic messages

In order to display PROFINET diagnostic messages of UPS1600 within the faceplate, the respective WinCC flexible/WinCC TIA Portal project must be configured.

A list of the PROFINET diagnostic messages of UPS1600 is available in the chapter 4 of the SITOP UPS1600 User Manual

(<https://support.industry.siemens.com/cs/ww/en/view/84977415>).

# Application of the function blocks

## 7.1 Application of the function blocks in SIMATIC STEP 7 V5.6

### 7.1.1 Prerequisites

#### FB163 requirements

The following requirements must be met in order to use the FB in combination with UPS1600 and SIMATIC STEP 7 V5.6:

- The GSD file of the UPS1600 is installed in the Hardware (HW) configuration of SIMATIC STEP 7 V5.6 and the UPS is configured as PROFINET node in the HW configuration of the SIMATIC S7 controller.
- S7 communication between UPS1600 and SIMATIC S7 controller is already configured.
- The library UPS1600 V3-0 STEP7 V5.6 is available on your computer.

#### Installation of GSD file

The required information about installation of the GSD file of the UPS1600 in SIMATIC STEP 7 V5.6 is available in the chapter 3.4.2 of the SITOP UPS1600 User Manual.

(<https://support.industry.siemens.com/cs/ww/en/view/84977415>)

#### S7 communication

The required information about establishing communication between a UPS1600 and a SIMATIC S7 controller is available in the chapter 3.4 of the SITOP UPS1600 User Manual

(<https://support.industry.siemens.com/cs/ww/en/view/84977415>).

## 7.1.2 Content of the library for SIMATIC STEP 7 V5.6

### Content of the library for SIMATIC STEP 7 V5.6

The library UPS1600 V3-0 STEP7 V5.6 contains:

- Blocks (FB1, FB2, UDT1 and UDT2)
- Symbol table Symbols\_UPS1600
- SCL source file of the code blocks FB1, FB2, UDT1 and UDT2
- "Text Libraries"

The table below shows the blocks available in the library.

Table 7- 1

Block	Name	Description
FB1	UPS1600	FB for program-controlled switch-off of the UPS1600
UDT1	LUPS1600_typeUPS1600Data	UDT provides the structure in the global data block for data exchange
FB2	UPS16Msg	FB to raise UPS1600 diagnostic alarms
UDT2	SStartInf	UDT structure of local data of OB82



## Opening the library in SIMATIC STEP 7 V5.6

Follow the procedure to open the library in a SIMATIC STEP 7 V5.6 project:

1. Open SIMATIC Manager.
2. In the menu bar, click "File > Open".  
The "Open Project" dialog box opens.
3. Select the "Libraries" tab.

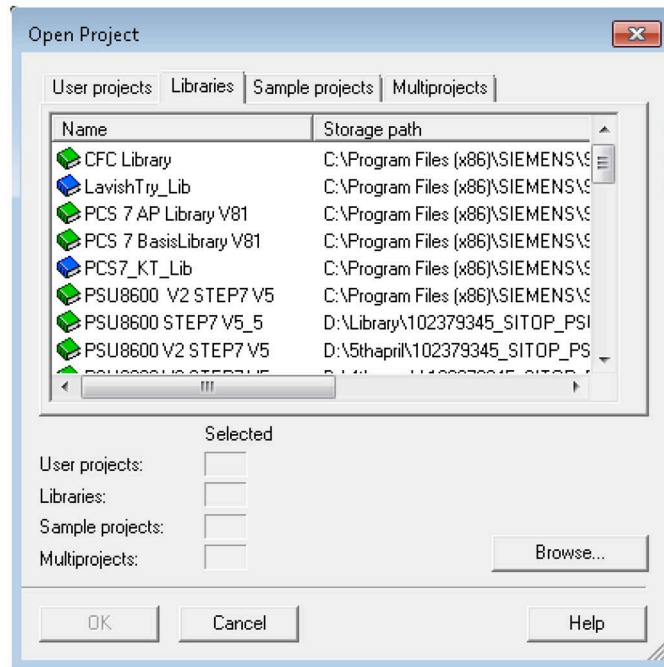

Figure 7-1

4. Click "Browse".  
The "Browse" dialog box opens.
5. Navigate to the stored location of the library in your computer and open the folders "SITOP-UPS1600\_Library\_STEP7-V5\_V3-0 > UPS1600 V3-0 STEP7 V5.6".

6. Select "UPS1600\_" and click "OK".

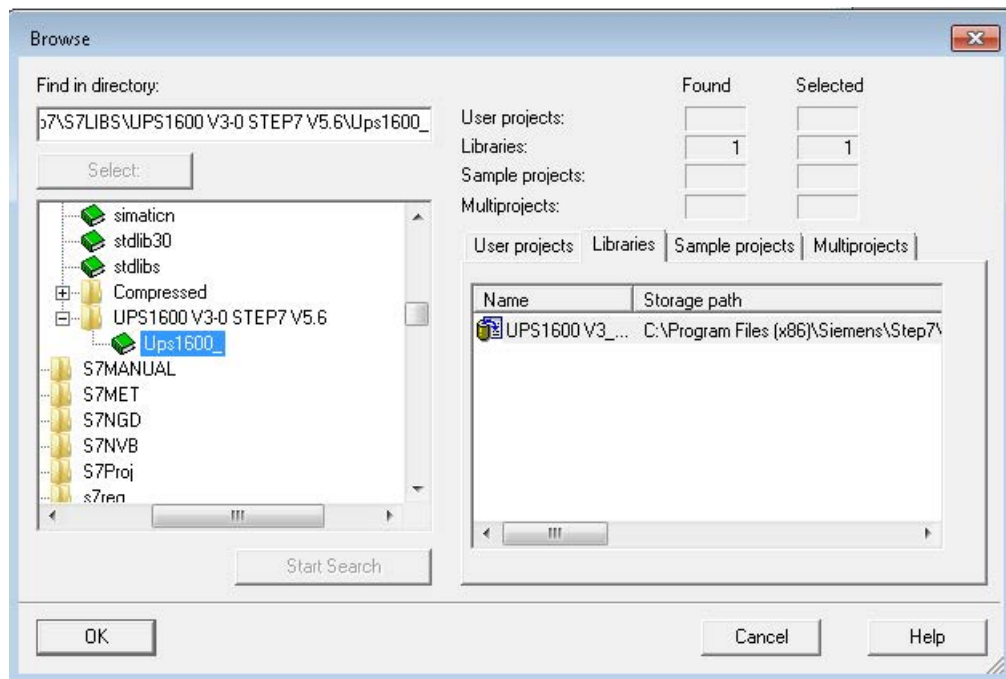

Figure 7-2

### 7.1.3 Interfaces of the function block

#### Block diagram

The following figure shows the block diagram of FB1:

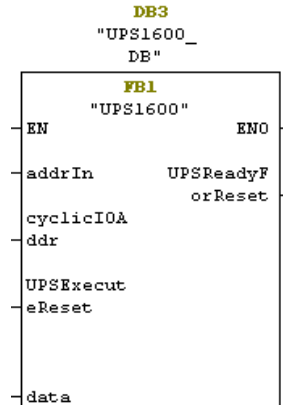

Figure 7-3

#### Interface description

The table below describes parameters of FB1:

Table 7- 2

Parameter	Declaration	Data type	Description
addrIn	Input	DWORD	PROFINET diagnostic address of the UPS1600 within the project. The diagnostic address must be specified in hexadecimal format.
cyclicIOAddr	Input	WORD	Input address of the UPS1600 within the project. The input address must be specified in hexadecimal format.
UPSExecuteReset	Input	BOOL	Switch-off signal to the UPS1600.
UPSReadyForReset	Output	BOOL	Signal for plant shutdown.
data	InOut	LUPS1600_typeUPS1600 Data	Data area for data exchange to the HMI faceplate.

The table below describes parameters of FB2:

Table 7- 3

Parameter	Declaration	Data type	Description
Diag_Address	Input	INT	PROFINET diagnostic address of the UPS1600 within the project. The diagnostic address must be specified in decimal format.
MsgEvId100_01 .. MsgEvId100-27	Input	DWORD	Message event ids for Device failures alarms
MsgEvId101_01 .. MsgEvId101-27	Input	DWORD	Message event ids for Device Diagnostic alarms
MsgEvId102_01 .. MsgEvId102-12	Input	DWORD	Message event ids for Battery Diagnostic alarms

## Input and diagnostic address of the UPS1600 module

To fetch the input and diagnostic address of the UPS1600 module, follow the instructions given below:

1. Open the hardware configuration settings of the PLC used in the project. The "HW Config - [SIMATIC 400(1) (Configuration)..." dialog box opens.
2. Select the UPS1600 module.
3. Note down the value in the "Diagnostic Address" column (A). We need to add value to the given parameter `addrIn` of FB1 and `Diag_Address` of FB2.
4. Note down value in the "I Address" column (B), value given to the parameter `cyclicIOAddr` of FB1.

Slot	Module	Order number	I Address	Q_address	Diagnostic Address	Com...
0	ups20	6EP4136-3AB00-2AY0		(A)	16375*	
	Device interface				16376*	
	Port 1 R				16377*	
	Port 2 R				16378*	
	Q.1				16379*	
	Q.2		512..519	(B)		
1	UPS1100 DC 24V 1.2Ah 10~	6EP4131-0GB00-0AY0			16374*	
2						
3						

Figure 7-4

In this case,

- `addrIn` value is 16375.
- `cyclicIOAddr` is 512.

## 7.1.4 LUPS1600\_typeUPS1600Data (UDT1)

### Data block DB15

The Data Block (DB) contains all the parameters of UPS1600 displayed within the HMI faceplate.

The following table lists all the parameters in UDT1:

Parameter	Data type	Remarks
orderNumber	STRING [20]	Order number (String)
serialNumber	STRING [20]	Serial number (String)
deviceName	STRING [20]	Device name (String)
versionNumber	STRING [30]	Version number (String)
batteryCapacity	REAL	[Ah]
endOfChargeVolt	REAL	[V]
chargeCur	REAL	[A]
maxOutCur	BYTE	[A]
inputVolt	REAL	[V]
inputCur	REAL	[A]
outputVolt	REAL	[V]
loadCur	REAL	[A]
measuredChargeCur	REAL	[A]
batteryVolt	REAL	[V]
outputCur	REAL	[A]
chargeVolt	REAL	[V]
bufferMode	BYTE	Active = 255 Inactive = 0; Undefined = 127
readyForBuffering	BYTE	Yes = 255; No = 0
batteryChargeLevel	BYTE	0 to 100% = battery charging; 255 = unknown battery
totalCalcBatCap	REAL	[Ah]
totalCalcBatHealth	BYTE	[%]
bufferTime	INT	[s]
bufferThreshold	REAL	[V]
bufferingAllowed	BYTE	[0/255]
commandID	INT	Remote reset = 8195
parameter1	BYTE	-
parameter2	BYTE	-
deviceHWRevision	INT	-
deviceSWRevision1	BYTE	-
deviceSWRevision2	BYTE	-
deviceSWRevision3	BYTE	-

---

**Note**

Further information about the system parameters is available in the SITOP UPS1600 User Manual (<https://support.industry.siemens.com/cs/ww/en/view/84977415>).

---

## 7.1.5 Integrating the function block

### Integrating FB1

The following sections describe all the steps required to integrate FB1 into a SIMATIC STEP 7 V5.6 project.

Hardware used:

- CPU 317-2 PN/DP
- SITOP UPS1600 24 V/20 A

The procedure for other SIMATIC S7 controllers is identical.

---

**Note**

Please ensure that all requirements for the integration of the FB are met. The requirements are described in these Prerequisites (Page 27).

---

### Inserting blocks from the library into the program

Follow the procedure to integrate FB1 and associated data blocks into a SIMATIC STEP 7 V5.6 project:

1. In the "SIMATIC Manager", open the required project.
2. Open the "Blocks" folder available in the connected PLC.
3. In the "SIMATIC Manager", open the global library UPS1600 V3\_0 STEP7 V5\_6 and select "UPS1600\_V3\_0 > Blocks".

The procedure for opening the library is described in Content of the library for SIMATIC STEP 7 V5.6 (Page 28).

4. Select all the blocks in the library and drag-and-drop them into the "Blocks" folder of your target project folder.

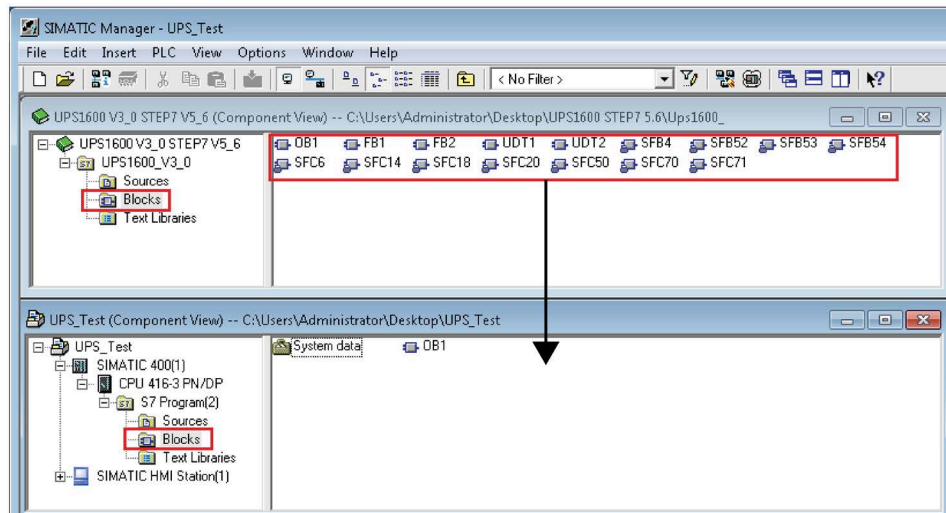

Figure 7-5

**Note**

The function blocks work properly with both, English and German mnemonics. In case the source code of the function blocks is required for a project, consider the following constraints:

- In case the language setting of your project is English, then the source code of the function blocks can be used as it is.
- In case the language setting of your project is German, then the entries IB (Input Byte) and IW (Input Word) of the sources have to be replaced with EB (EingangsByte)

5. Insert OB40 in order to avoid PLC going to stop mode in case of hardware interrupt.



## Inserting Text libraries from the library into the program

Follow the procedure to insert "Text Libraries" from the library into a SIMATIC STEP 7 V5.6 project:

1. In the "SIMATIC Manager", open the required project.
2. Open the "S7 Program" folder available in the connected PLC. Insert Text Library folder under S7 Program folder if it doesn't exist.
3. In the "SIMATIC Manager", open the global library UPS1600 V3\_0 STEP 7 V5\_6 and select "UPS1600\_V3\_0".
4. The procedure for opening the library is described in Content of the library for SIMATIC STEP 7 V5.6.
5. Copy "SITOP\_MODULES", "SITOP\_UPS1600\_DiagText", "SITOP\_UPS1600\_HlpText" which are present under "Text Libraries" folder in the library and paste them into the "Text Libraries" folder of target project folder.
6. Open text library "SITOP\_MODULES" and make an entry to the text library with index as modules diagnostic address and PSU8600/UPS1600 device name under English/German Language column as shown below.

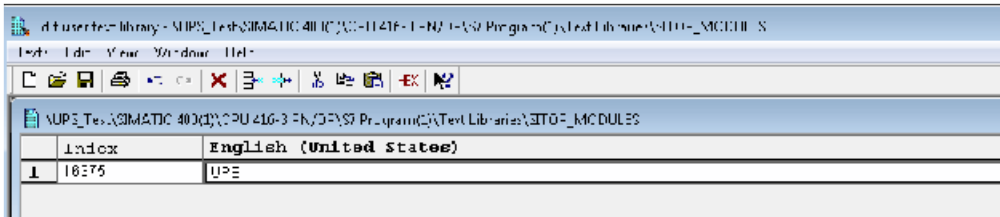

Index	English (United States)
18375	UPS

Figure 7-6

7. Save and close text library.

### Create a global data block with UDT structure

Follow the procedure to create a global DB with UDT:

1. In your project, open the "Blocks" folder available in the connected PLC folder.
2. Right-click on the blocks element area and select "Insert New Object > Data Block".  
The "Properties - Data Block" dialog box opens to create a DB.
3. In the "Properties - Data Block" dialog box,
  - Enter a name and number for the DB (DB15) in the "Name and type:" text box.
  - For the same field, open the first drop-down list and select "Shared DB".
  - Enter a symbolic name as desired (UPS\_Global) in the "Symbolic Name:" text box.

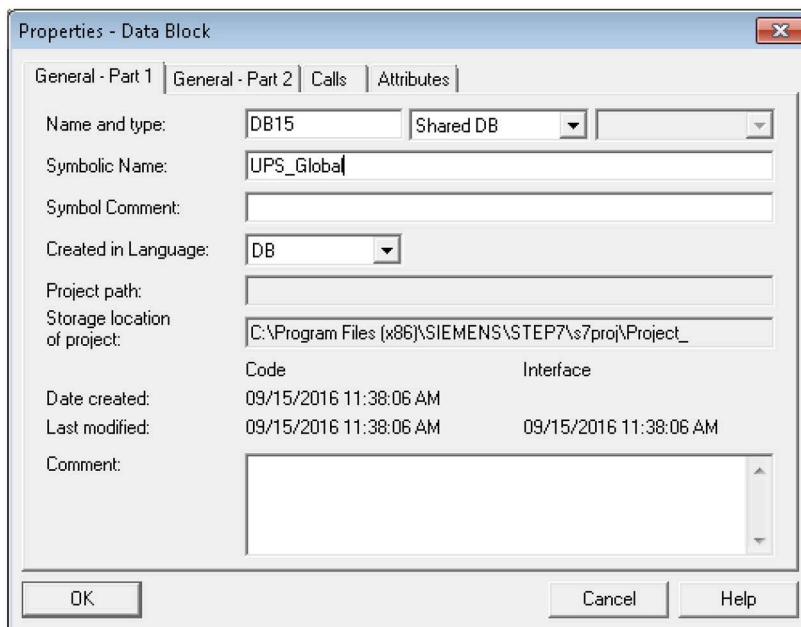

Figure 7-7

4. Click "OK".  
The created DB appears in the "Blocks" folder.
5. Open the DB created in Step 2 (DB15).  
A new window opens.

6. At the address "+0.0",
  - In the "Name" column, enter a name for your tag (UPS).
  - In the "Type" column, replace INT with LUPS1600\_typeUPS1600Data.
  - In the "Initial" column, delete the initial value and remove the comment.

Address	Name	Type	Initial value	Comment
0.0		STRUCT		
+0.0	DE_VAR	INT	0	Temporary placeholder variable
=2.0		END_STRUCT		

Address	Name	Type	Initial value	Comment
0.0		STRUCT		
+0.0	UPS	"LUPS1600_typeUPS1600Data"		
=172.0		END_STRUCT		

Figure 7-8

7. Save the settings and close the window.

### Calling the function block FB1

Follow the procedure to call the FB within an organization block (OB). In this description, FB1 is called within OB33:

1. In the "Blocks" folder of the controller, create an instance DB.
2. Right click on the blocks element area and select "Insert New Object > Data block". The "Properties - Data Block" dialog box opens.
3. In the "Properties - Data Block" dialog box,
  - Enter a name and number for the DB (DB3) in the "Name and type:" text box.
  - For the same field, select "Instance DB" and "FB1" from the drop-down lists.
  - Enter the symbolic name as "UPS1600\_DB" in the "Symbolic name:" text box.
  - Click "OK".

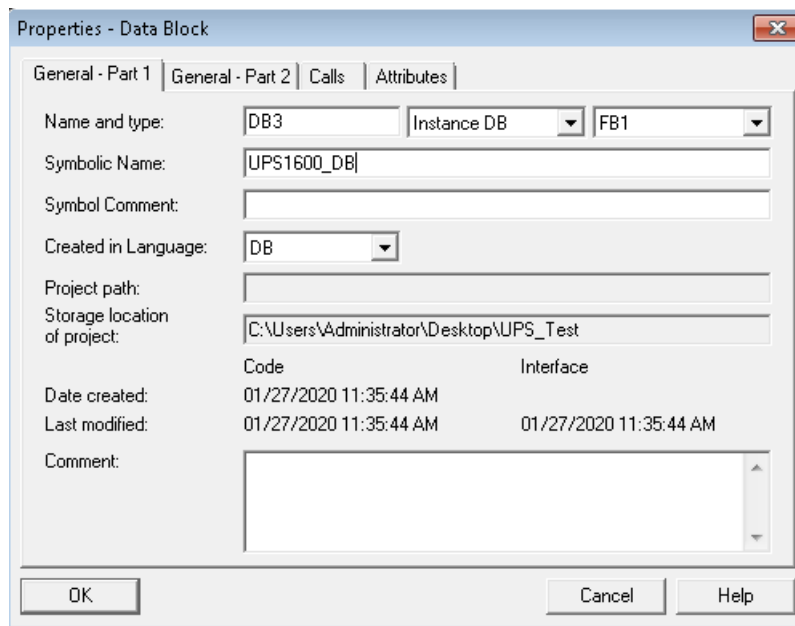

Figure 7-9

4. In the same "Blocks" folder, create an Organization Block (OB) with the name OB33.  
(Right click and select "Insert New Object > Organization block".)

Open the created OB33.

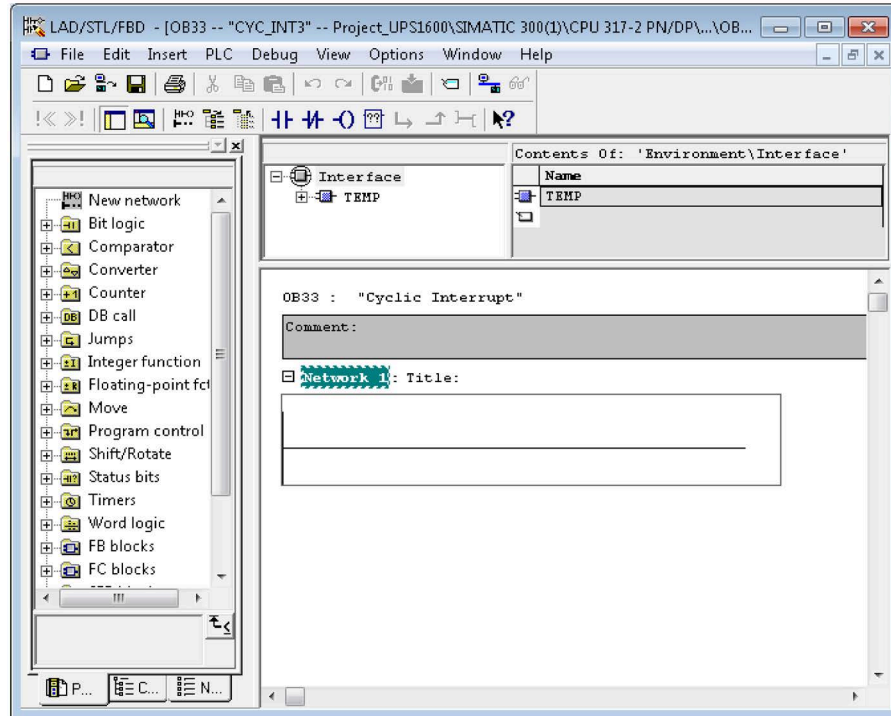

Figure 7-10

5. In the "Program elements" tab, expand the "FB blocks" folder.

6. Drag-and-drop "FB1 UPS1600 UPS1600" onto the empty network area.

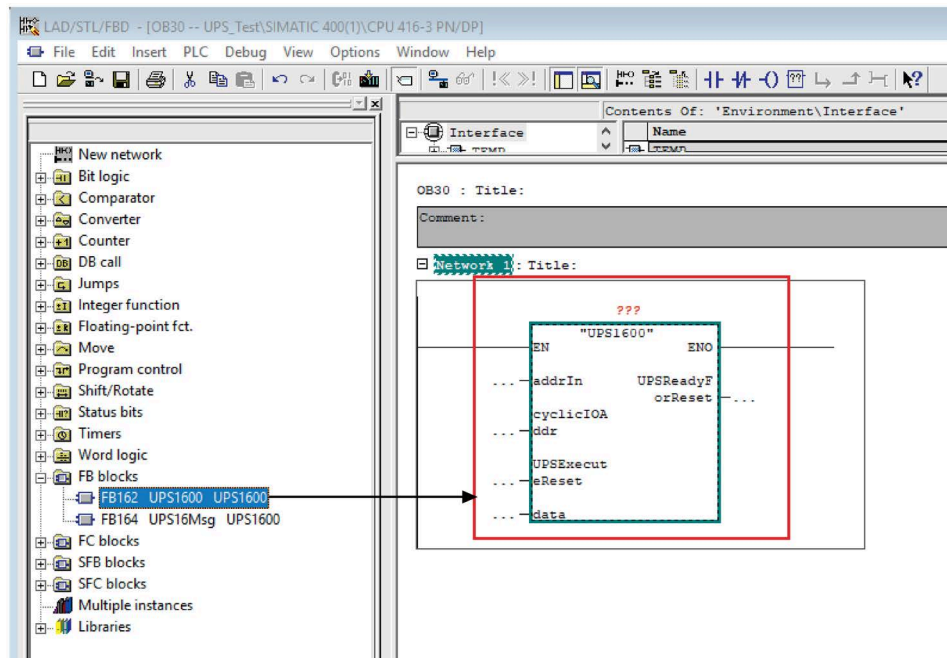

Figure 7-11

7. For the block in the network area,
  - Interconnect FB1 with the instance DB created in step 1 (DB3).
  - For the parameter `addrIn`, enter the PROFINET diagnostic address of the SITOP UPS1600 within your STEP 7 project (DW#16#3FF7).
  - For the parameter `cyclicIOAddr`, enter the input address of the SITOP UPS1600 within your STEP 7 project (W#16#200).
  - Connect the parameter `UPSReadyForReset` to the tag through which you bring the plant into a safe state (flag M0.0 is used).
  - Connect the parameter `UPSExecuteReset` to the tag through which you switch off the UPS (flag M0.1 is used).

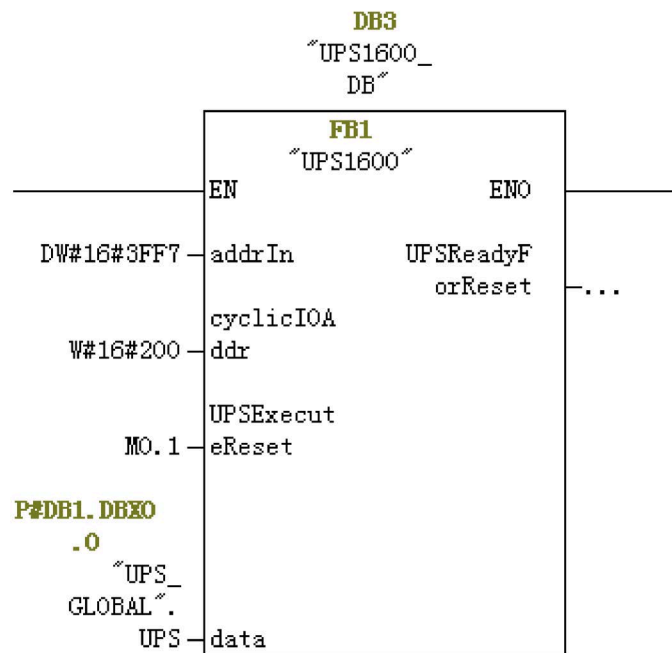

Figure 7-12

For further information about the block parameters, see Interfaces of the function block (Page 31).

8. Save the changes and close the window.

**Note**

**`addrIn` and `cyclicIOAddr` of FB1**

To know the diagnostic and input address of FB1, refer to section **Input and diagnostic address of the UPS1600 module** in Interfaces of the function block (Page 31).

### Calling the function block FB2

Follow the procedure to call the FB2 within an organization block (OB). In this description, FB2 is called within OB82:

1. In the "Blocks" folder of the controller, create an instance DB.
2. Right click on the blocks element area and select "Insert New Object > Data block". The "Properties - Data Block" dialog box opens.
3. In the "Properties - Data Block" dialog box,
  - Enter a name and number for the DB (DB2) in the "Name and type:" text box.
  - For the same field, select "Instance DB" and "FB2" from the drop-down lists.
  - Enter the symbolic name as "UPS16Msg\_DB" in the "Symbolic name:" text box.
  - Click "OK".

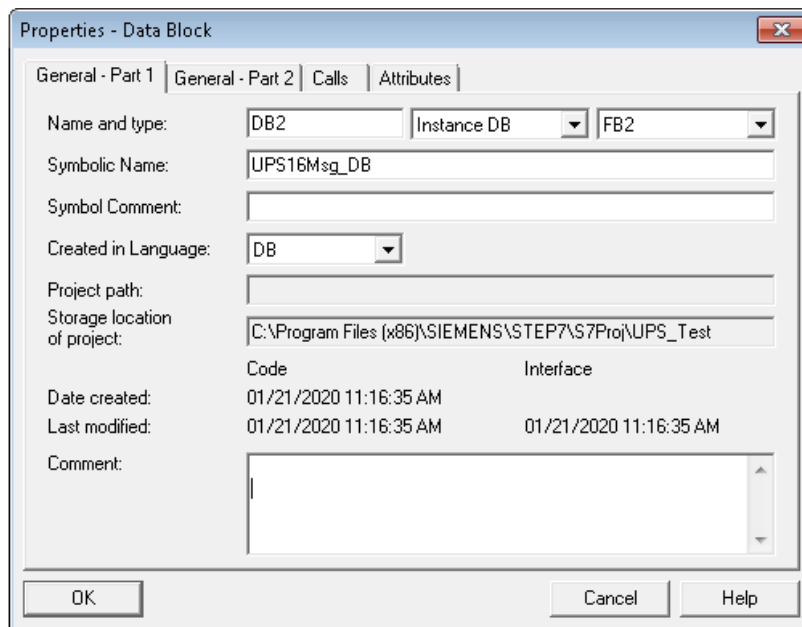

Figure 7-13



4. In the same "Blocks" folder, create an Organization Block (OB) with the name OB82. (Right click and select "Insert New Object > Organization block".) Open the created OB82.

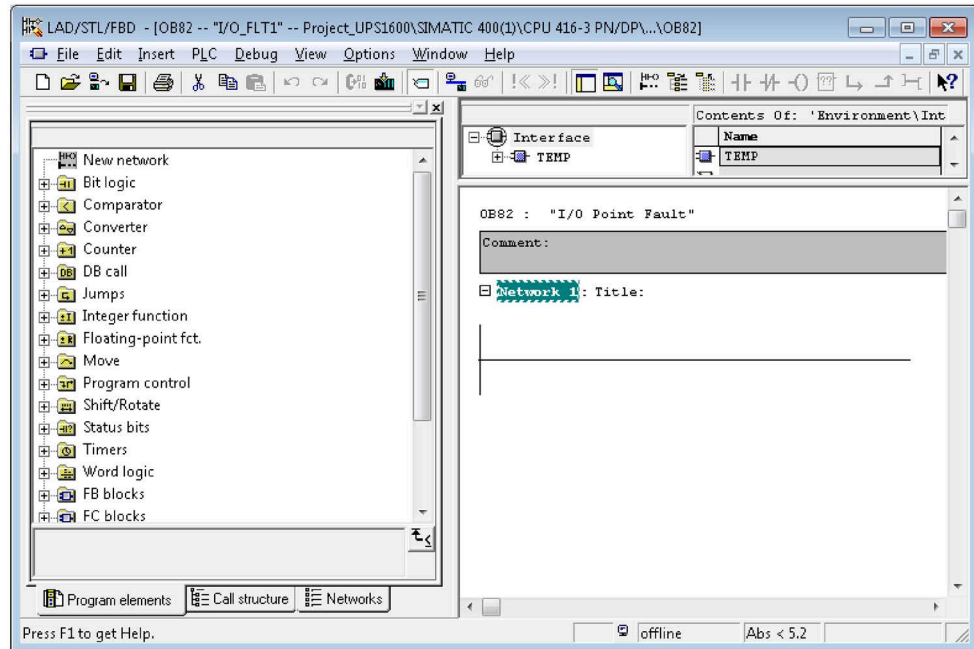

Figure 7-14

5. In the "Program elements" tab, expand the "FB blocks" folder.

6. Drag-and-drop "FB2 UPS16Msg UPS1600" onto the empty network area.

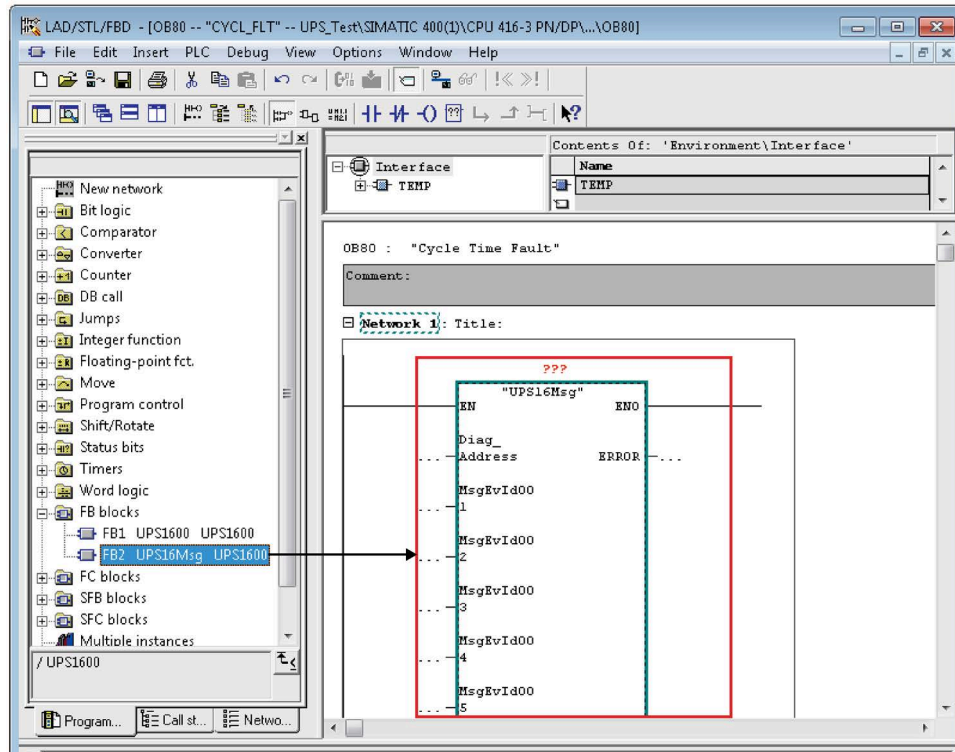

Figure 7-15

7. For the block in the network area,
- Interconnect FB2 with the instance DB created in step 1 (DB2).
  - For the parameter `Diag_Address`, enter the PROFINET diagnostic address of the SITOP UPS1600 within your SIMATIC STEP 7 project (16375).

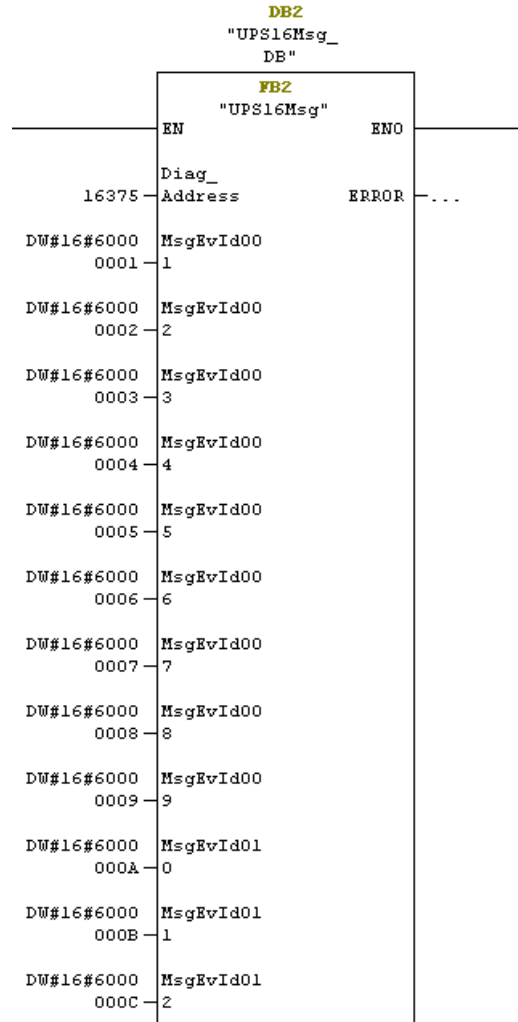

Figure 7-16

8. Save the changes and close the window.

Follow the same procedure to call FB2 in OB86 and cyclic interrupt OB. In this example OB33 with the same instance DB which is created in step 3.

### Note

#### Diag\_Address of FB2

To know the diagnostic and input address of FB2, refer to section **Input and diagnostic address of the UPS1600 module** in Interfaces of the function block (Page 31)

## 7.2 Application of the function blocks under STEP 7 Professional V15.1

### 7.2.1 Prerequisites

#### Requirements

The following requirements must be met in order to use the FB in combination with UPS1600 and STEP 7 V15.1:

- Hardware Support Package (HSP) for UPS1600 is installed in STEP 7 V15.1.
- S7 communication between UPS1600 and SIMATIC S7 controller is already configured.
- LUPS1600 is available on your computer.

#### Installation of Hardware Support Package

The required information about installation of Hardware Support Package of UPS1600 in STEP 7 V15.1 is available in the chapter 3.3.2 of the SITOP UPS1600 User Manual (<https://support.industry.siemens.com/cs/ww/en/view/84977415>).

#### S7 communication

The required information about establishing communication between UPS1600 and a SIMATIC S7 controller is available in the chapter 3.3 of the SITOP UPS1600 User Manual (<https://support.industry.siemens.com/cs/ww/en/view/84977415>).

## 7.2.2 Content of the library for STEP 7 V15.1

### Content of the library for STEP 7 V15.1

The STEP 7 V15.1 library contains the library elements for:

- S7-300/400
- S7-1200/1500

The following sections describes in detail about the library elements and how to open the library in STEP 7 V15.1.

### Library elements S7-300/400 and S7-1200/1500

The following code blocks are present in this library element:

Table 7- 4

Folder	Description
FB	It contains the LUPS1600_UPS1600 function block for program-controlled switch-off of the UPS1600.
UDT	LUPS1600_typeUPS1600Data UDT stores all parameters of UPS1600.

### Opening the library in STEP 7 V15.1

Follow the procedure to open the library in STEP 7 V15.1 project:

1. Open STEP 7 V15.1 in the "Project view" and select the "Libraries" tab.
2. Under the "Global libraries" palette, click on the highlighted icon to import the library. The "Open global library" dialog box opens.

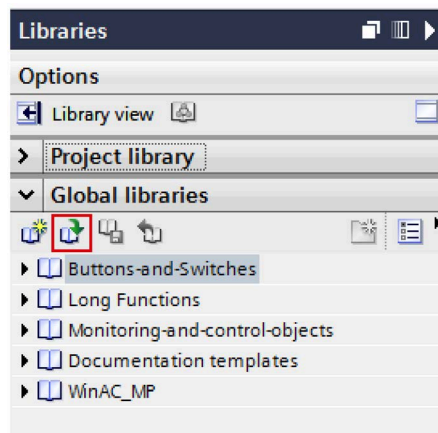

Figure 7-17

3. In the "Look in:" drop-down list, navigate to the stored location of the library folder LUPS1600 on your computer and open it.

4. Select "LUPS1600".

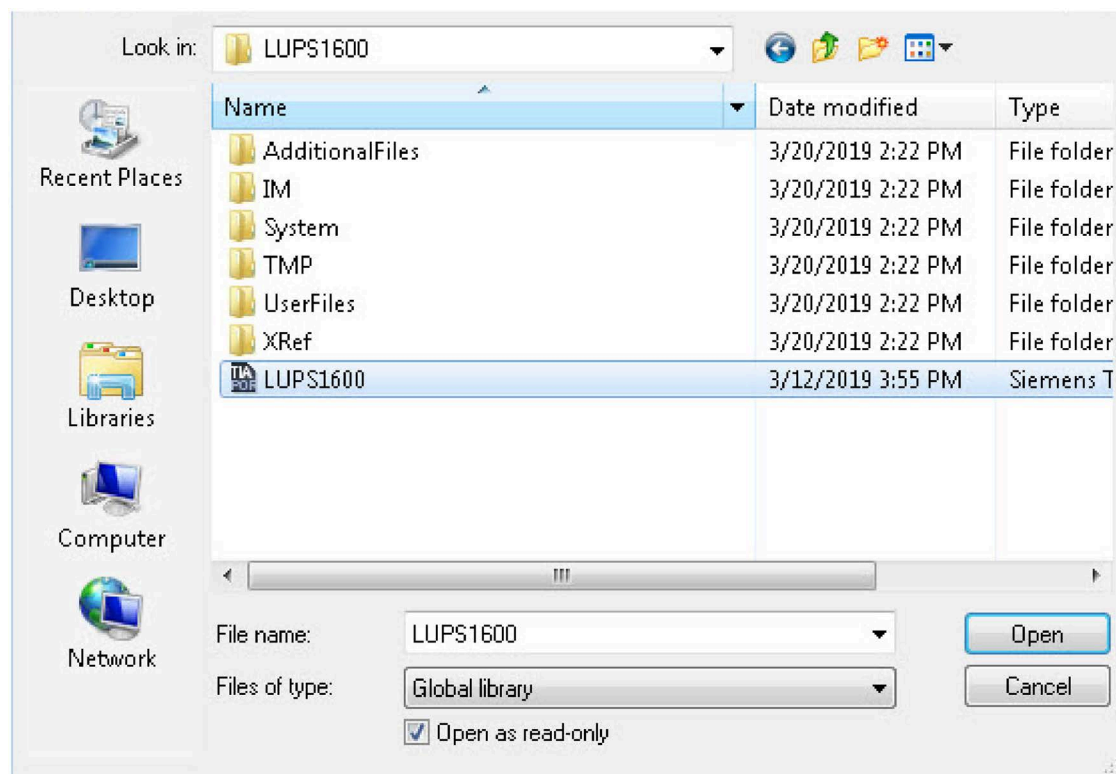

Figure 7-18

5. Click "Open".

The library is displayed in the "Global libraries" palette.

### 7.2.3 Interfaces of the function block FB165

#### Function block FB165 for S7-300/400

##### Block diagram

The following figure shows the block diagram of FB165:

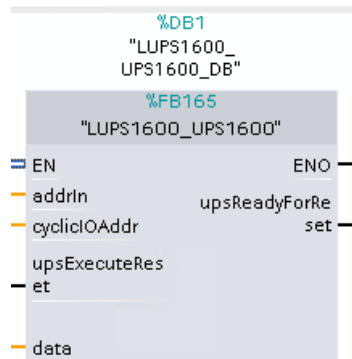

Figure 7-19

##### Interface description

Parameter	Declaration	Data type	Description
addrIn	Input	DWORD	PROFINET diagnostic address of the UPS1600 within the project. The input address can be specified in both hexadecimal and decimal format.
cyclicIOAddr	Input	WORD	I/O Data input address of UPS1600 within the project. The input address can be specified in both hexadecimal and decimal format.
upsExecuteReset	Input	BOOL	Switch-off signal to the UPS1600
data	InOut	LUPS1600_typeUPS1600 Data	Data area for data exchange to the HMI faceplate.
upsReadyForReset	Output	BOOL	Signal for plant shutdown

**addrIn and cyclicIOAddr of FB165 for S7-300/400**

To fetch the input and diagnostic address of the UPS1600 module for S7-300/400, follow the instructions given below:

1. In the "Project tree", open "Devices and Networks".
2. Select the UPS1600 module and go to "Device view > Device overview".
3. Note down the value in the "I address" column (A), this value is given to the parameter `addrIn`.
4. Select the UPS1600 module and go to "Properties > General > I/O data > I/O addresses > Input addresses"
5. Note down the value in the "Start address" variable (B), this value is given to the parameter `cyclicIOAddr`.

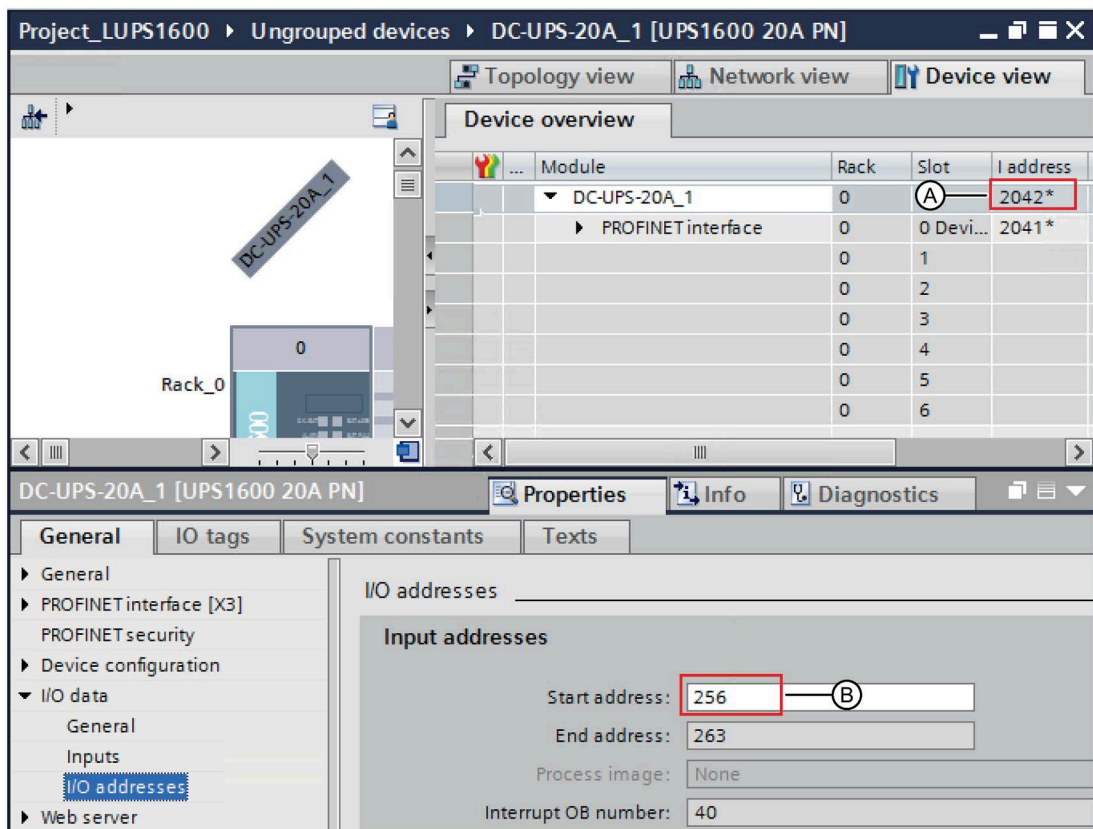

Figure 7-20

In this case,

- Value of `addrIn` is 2042 (A).
- Value of `cyclicIOAddr` is 256 (B).



## Function block FB165 for S7-1200/1500

### Block diagram

The following figure shows the block diagram of the FB165:

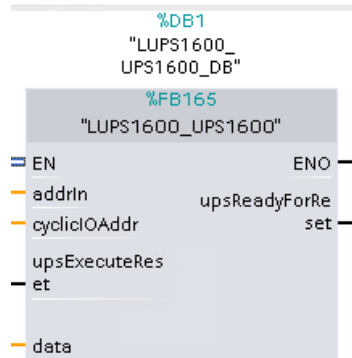

### Interface description

Table 7- 5

Parameter	Declaration	Data type	Description
addrIn	Input	HW_IO	Hardware ID of the UPS1600 within the project, for example: DC-UPS-20A_1~Head.
cyclicIOAddr	Input	HW_IO	IO Data submodule address of UPS1600 within the project
upsExecuteReset	Input	BOOL	Switch-off signal to the UPS1600
data	InOut	LUPS1600_typeUPS1600 Data	Data area for data exchange to the HMI faceplate.
upsReadyForReset	Output	BOOL	Signal for plant shutdown

**addrIn and cyclicIOAddr of FB165 for S7-1200/1500**

To fetch the input and diagnostic address of the UPS1600 module for S7-1200/1500, follow the instructions given below:

1. In the "Project tree", open "Devices and Networks".
2. In the "Network view", select the UPS1600 module and go to "Properties > System constants".
3. Note down the value in the "Hardware identifier" column of DC-UPS-20A\_1~Head (A), value given to `addrIn`.
4. Note down the value in "Hardware identifier" column of DC-UPS-20A\_1~IO\_Data\_Submodule (B), value given to `cyclicIOAddr`.

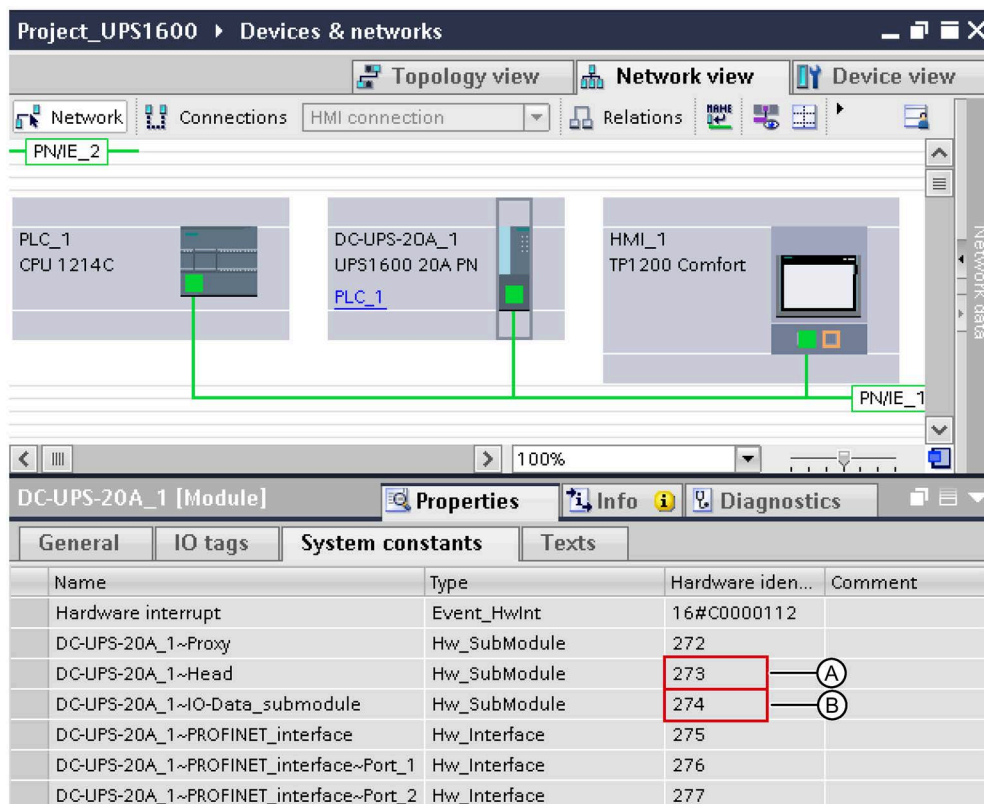

Figure 7-21

In this case,

- Value of `addrIn` is DC-UPS-20A\_1~Head or 273 (A).
- Value of `cyclicIOAddr` is DC-UPS-20A\_1~IO-Data\_Submodule or 274 (B).

## 7.2.4 LUPS1600\_typeUPS1600Data

The data block contains parameters of UPS1600 displayed within the HMI faceplate.

The following table lists parameters present in LUPS1600\_typeUS1600Data:

Parameter	Data type	Remarks
orderNumber	STRING [20]	Order number (String)
serialNumber	STRING [20]	Serial number (String)
deviceName	STRING [20]	Device name (String)
versionNumber	STRING [30]	Version number (String)
batteryCapacity	REAL	[Ah]
endOfChargeVolt	REAL	[V]
chargeCur	REAL	[A]
maxOutCur	BYTE	[A]
inputVolt	REAL	[V]
inputCur	REAL	[A]
outputVolt	REAL	[V]
loadCur	REAL	[A]
measuredChargeCur	REAL	[A]
batteryVolt	REAL	[V]
outputCur	REAL	[A]
chargeVolt	REAL	[V]
bufferMode	BYTE	Active = 255 Inactive = 0; Undefined = 127
readyForBuffering	BYTE	Yes = 255; No = 0
batteryChargeLevel	BYTE	0 to 100% = battery charging; 255 = unknown battery
totalCalcBatCap	REAL	[Ah]
totalCalcBatHealth	BYTE	[%]
bufferTime	INT	[s]
bufferThreshold	REAL	[V]
bufferingAllowed	BYTE	[0/255]
commandID	INT	Remote reset = 8195
parameter1	BYTE	-
parameter2	BYTE	-
deviceHWRevision	INT	-
deviceSWRevision1	BYTE	-
deviceSWRevision2	BYTE	-
deviceSWRevision3	BYTE	-

## **7.2.5 Integrating the function block**

### **7.2.5.1 Procedure when using an S7-300/400**

#### **Overview**

Hardware used:

- CPU 315-2 PN/DP
- SITOP UPS1600 24V/20A

The procedure for other SIMATIC S7-300/400 controllers is identical.

---

#### **Note**

Please ensure that all the requirements for the integration of the FB are met. The requirements are described in the Prerequisites (Page 48).

---

#### **Inserting blocks from the library into the program**

Follow the procedure to insert the FB165 and associated data blocks into a STEP 7 V15.1 project:

1. Open the required project in "Project view".
2. In the "Libraries" window, under "Global libraries", open the library "LUPS1600".

The procedure for opening LUPS1600 global library is described in Content of the library in STEP 7 V15.1 (Page 49).

3. In the library, select "Types > LUPS1600 > STEP7 > S7-300/400 > FB > LUPS1600\_UPS1600".

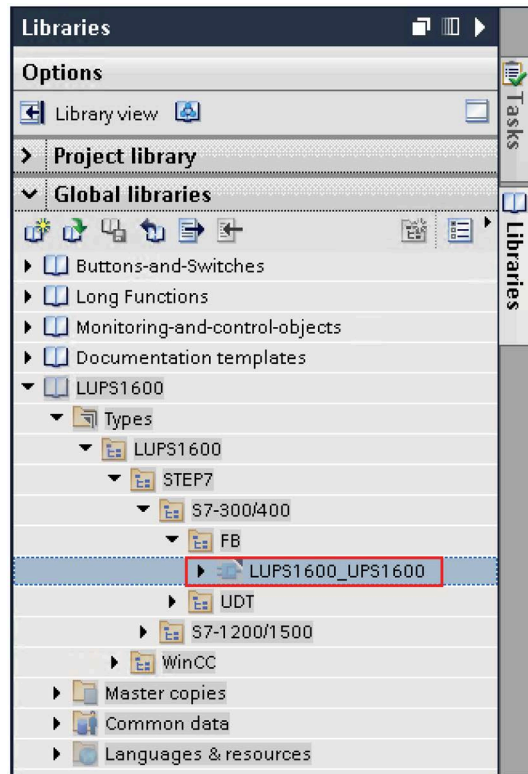

Figure 7-22

4. Drag-and-drop "LUPS1600\_UPS1600" into the "Program blocks" folder in the "Project tree".

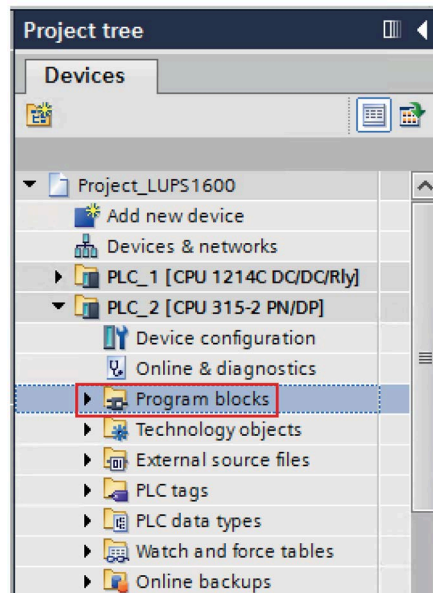

Figure 7-23



## Calling the function block

Follow the procedure to call FB165 within an Organization Block (OB). In this description, FB165 is called within OB35:

1. In the "Project tree", open the "Program blocks" folder.
2. Create a cyclic interrupt OB with the name "CYC\_INT5 [OB35]" and open it. This displays an empty network.
3. From the "Program blocks" folder, drag-and-drop "LUPS1600\_UPS1600 [FB165]" to the empty network of OB35. The "Call options" dialog box opens.

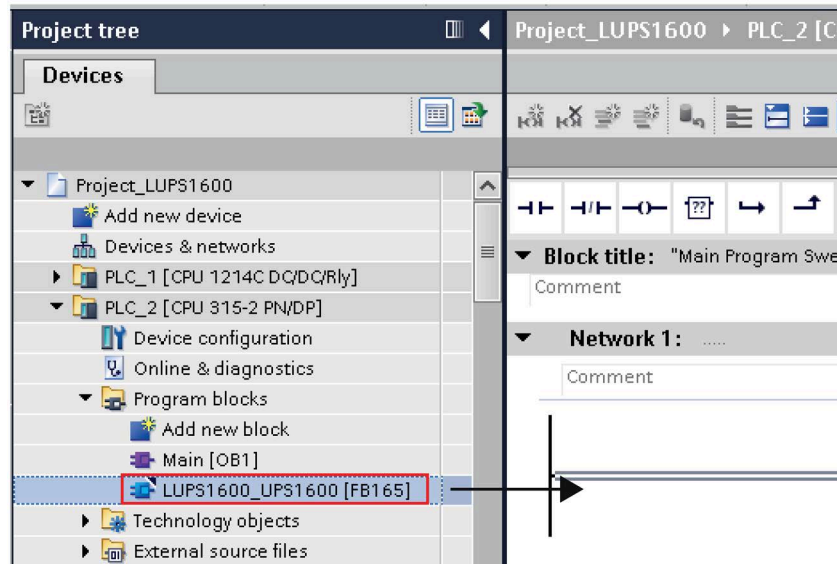

Figure 7-24

4. Keep the default settings of the dialog box and click "OK".
5. Double click on "Add new block" to add a new DB. The "Add new block" window opens.

6. In the "Add new block" window,
  - Select "Data block"
  - Enter a name as desired (UPS\_Global).
  - In the "Type:" drop-down list, select "Global DB".
  - Click "OK".

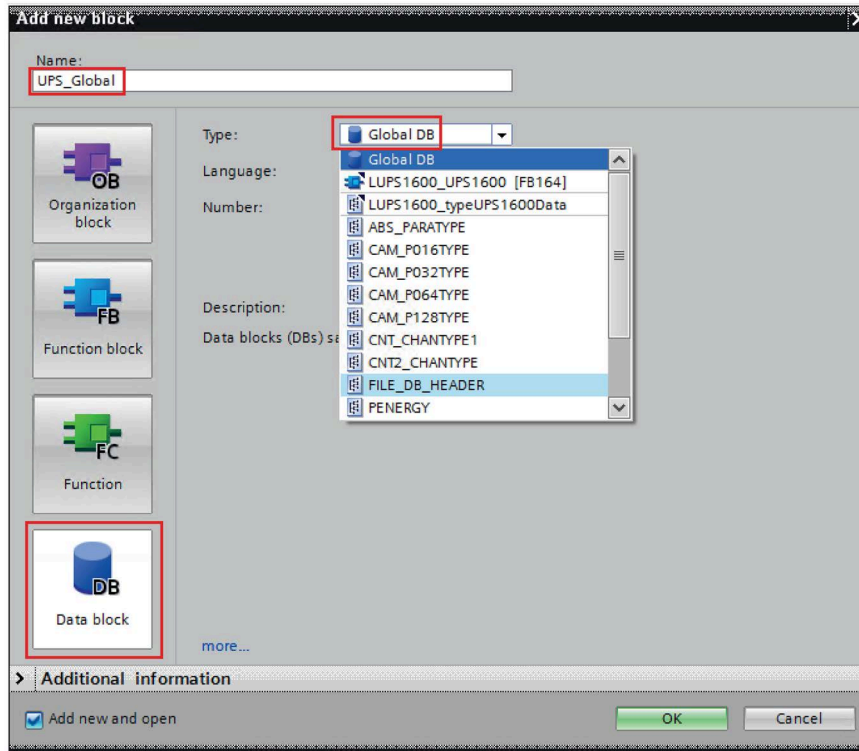

Figure 7-25



- Open the global DB created in step 6 (UPS\_Global). Add a new tag with data type as "LUPS1600\_typeUPS1600Data".

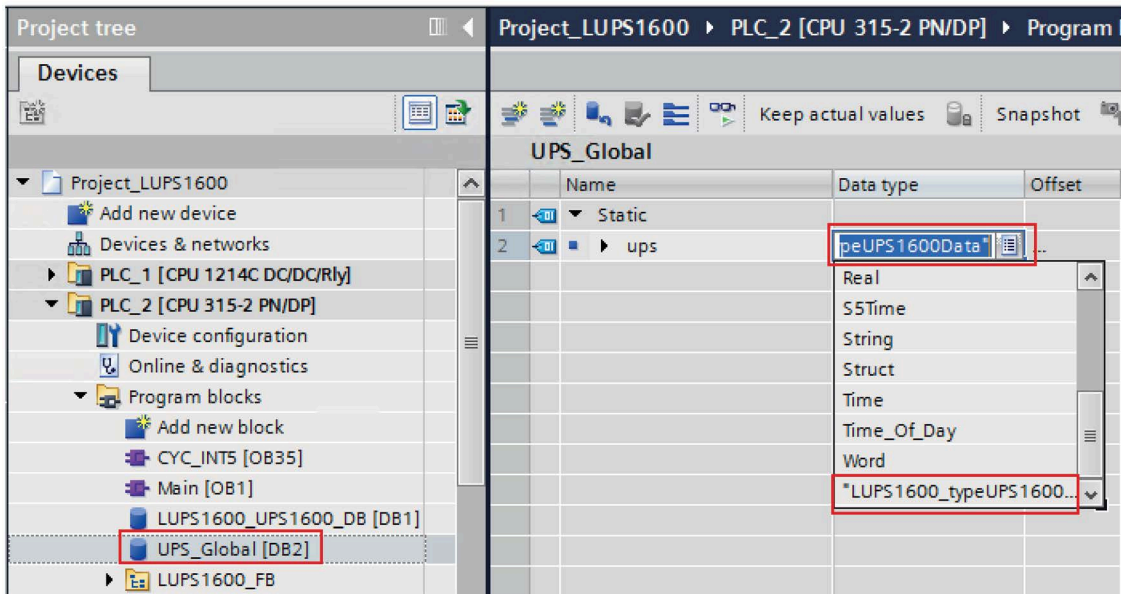

Figure 7-26

- In the network area of OB35,

---

#### Note

OBs are called cyclically and in numerical order. Observe this when calling the communication blocks in an operation block. This ensures that you are reading the current data of the power supply.

---

- For the parameter `addrIn`, enter the PROFINET diagnostic address of the UPS1600 module (2042).
- For the parameter `cyclicIOAddr`, enter the start address of the UPS1600 module (68).
- Connect the parameter `upsReadyForReset` with a tag of your project that you use to bring the plant into a condition in which it can be shut down.
- Connect the parameter `upsExecuteReset` with a tag of your project that you use to switch off the UPS when the plant is in a condition in which it can be shut down.

- Connect the parameter `data` with Global DB UPS\_Global.

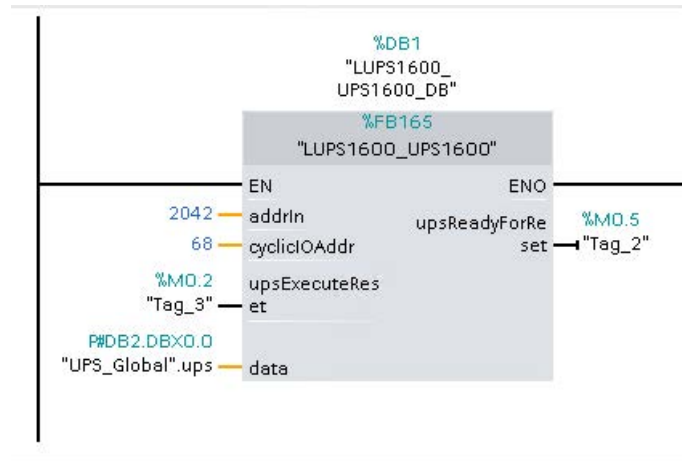

Figure 7-27

**Note**

**addrIn and cyclicIOAddr parameters**

To know the `addrIn` and `cyclicIOAddr` parameter values of the UPS1600 module, refer to Interfaces of the function block FB165 (Page 51).

## 7.2.5.2 Procedure when using an S7-1200/1500

### Overview

Hardware used:

- CPU 1214C DC/DC/Rly
- SITOP UPS1600 24 V/20 A

The procedure for other SIMATIC S7-1200/1500 controllers is identical.

---

#### Note

Please ensure that all requirements for the integration of the FB are met. The requirements are described in the Prerequisites (Page 48).

---

### Inserting blocks from the library into the program

Follow the procedure to insert the blocks and the associated data blocks into a STEP 7 V15.1 project:

1. Open the required project in "Project view".
2. In the "Libraries" tab, under "Global libraries", open the library "LUPS1600".  
The procedure for opening the library is described in the Content of the library in STEP 7 V15.1 (Page 49).

3. In the library, select "Types > LUPS1600 > STEP7 > S7-1200/500 > FB > LUPS1600\_UPS1600".

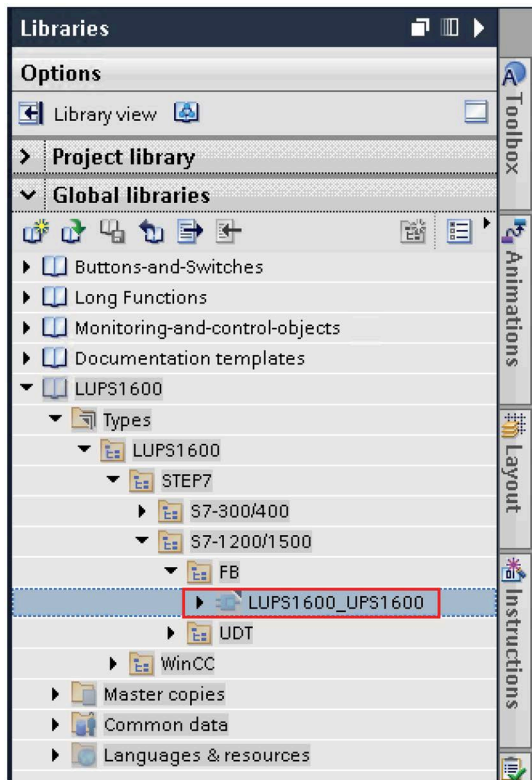

Figure 7-28

4. Drag-and-drop "LUPS1600\_UPS1600" into the "Program blocks" folder in the "Project tree".

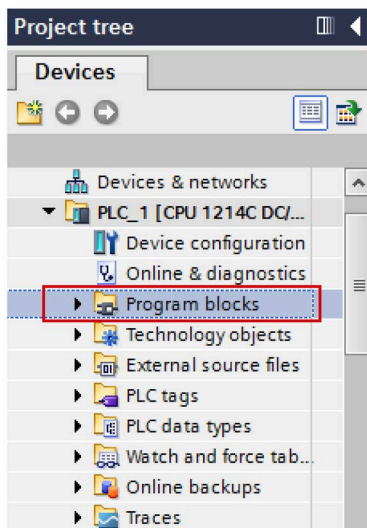
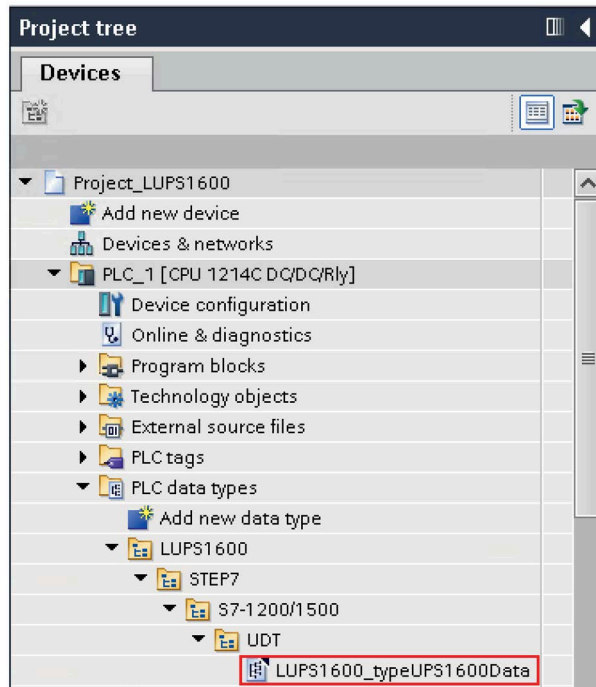

Figure 7-29

**Note**

Even "LUPS1600\_typeUPS1600Data" will be automatically copied to the "PLC data types" folder in the "Project tree".



### Calling the function block

Follow the procedure to call the FB within an organization block (OB). In this description, FB165 is called within OB30:

1. In the "Project tree", open the "Program blocks" in the controller.
2. Create an OB with the name "Cyclic interrupt [OB30]" and open it. This displays an empty network.
3. Drag-and-drop "LUPS1600\_UPS1600 [FB165]" from the "Program blocks" folder to the empty network of OB30. The "Call options" dialog box opens.

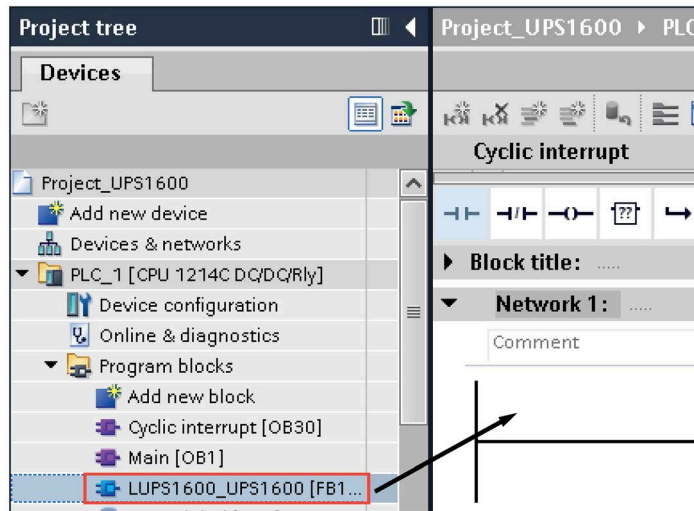

4. Keep the default settings of the dialog box and click "OK".
5. Double click on "Add new block" to add a new DB. The "Add new block" window opens.

6. In the "Add new block" window,
  - Select "Data block".
  - Enter a name as desired (UPS\_Global).
  - In the "Type:" drop-down list, select "LUPS1600\_typeUPS1600Data".
  - Click "OK".

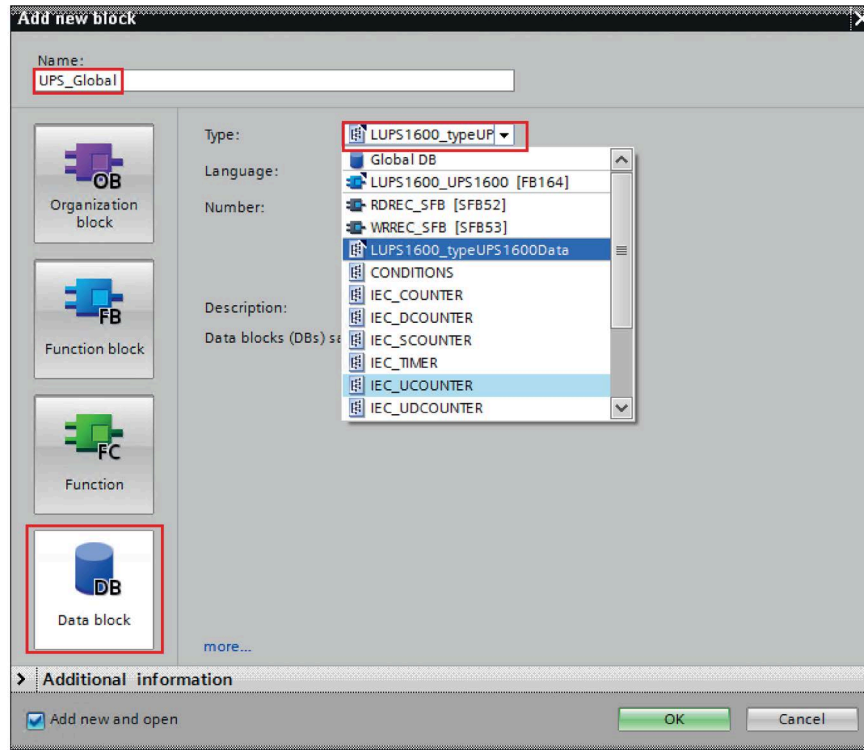

Figure 7-30

7. Right click on the global DB created in step 5 (UPS\_Global) and go to "Properties > General > Attributes".
8. In the network area of OB30 for FB165,
  - For the parameter `addrIn`, enter the hardware ID of DC-UPS-20A\_1~Head of the UPS1600 (281).
  - For the parameter `cyclicIOAddr` enter the hardware ID of DC-UPS-20A\_1~Data\_submodule of the UPS1600 (282).
  - Connect the parameter `upsReadyForReset` with a tag of your project that you use to bring your plant into a condition in which it can be shut down.
  - Connect the parameter `upsExecuteReset` with a tag of your project that you use to switch off the UPS when the plant is in a condition in which it can be shut down.
  - Connect the parameter `data` with the global DB created in step 6, (UPS\_Global).

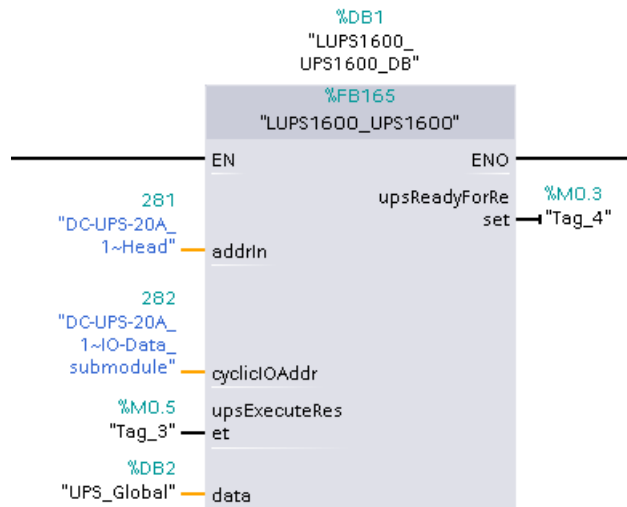

Figure 7-31

Further information about the block parameters, refer to Interfaces of the function block FB165 (Page 51).

**Note**

**`addrIn` and `cyclicIOAddr` parameters**

To know the `addrIn` and `cyclicIOAddr` parameter values of your UPS1600 module, refer to Interfaces of the function FB165 (Page 51).



# Application of the faceplates

## 8.1 Application of the faceplates in WinCC flexible 2008

### 8.1.1 Prerequisites

#### Requirements

The following requirements must be met to use the faceplates in WinCC flexible 2008 SP5:

- The GSD file of the SITOP UPS1600 is installed in SIMATIC STEP 7 V5.6 and UPS is configured as PROFINET node in the HW configuration of the CPU.
- S7 communication between SITOP UPS1600 and CPU is already configured.
- All the program blocks from the library UPS1600 V3\_0 STEP 7 V5\_6 are integrated into the STEP 7 application program and executable.
- The library 'UPS1600 V3\_0 library WinCC Flexible 2008' for WinCC flexible 2008 SP5 is available on your computer.

#### Supported control panels

The faceplates are supported for the following control panels:

- TP270 10"
- OP270 10"
- MP270 10" Touch
- MP277 8" Touch/Key
- MP277 10" Touch/Key
- MP377 Touch/Key
- WinCC flexible Runtime 2008 SP5

#### Supported languages

The faceplates support the following languages:

- English (USA)
- German (Germany)
- Chinese (PR China)

## 8.1.2 Library for WinCC flexible

### Library for WinCC flexible

The library 'UPS1600 V3\_0 library WinCC flexible 2008' for WinCC flexible 2008 SP5 comprises of the following objects:

Table 8- 1

Name	Type	Description
UPS1600 V3_0 HMI Tag table	Tag folder	A tag folder with all the required tags
Faceplate_UPS1600_V3_0	Faceplate	Contains the faceplate 'Faceplate_UPS1600_V3_0'.
HMI Alarm views	Message window	Contains two message windows for displaying diagnostic messages of the UPS1600
UPS1600_Data	Structure	Contains a group of structure elements required for UPS1600 faceplate

## 8.1.3 Integrating the faceplates

### Overview

The following sections describe all the steps required to integrate a faceplate into a WinCC flexible 2008 SP5 project.

Hardware used:

- MP277 8" Touch

An overview of the supported HMI control panels is available in the Prerequisites (Page 69).

## Opening the library

The following procedure describes how to open the library in WinCC flexible 2008 SP5:

1. Open the WinCC flexible project into which you want to insert the faceplate.
2. In the "Tools" window, select the "Library" tab and click on the highlighted icon to open the library. The "Open global library" dialog box opens.

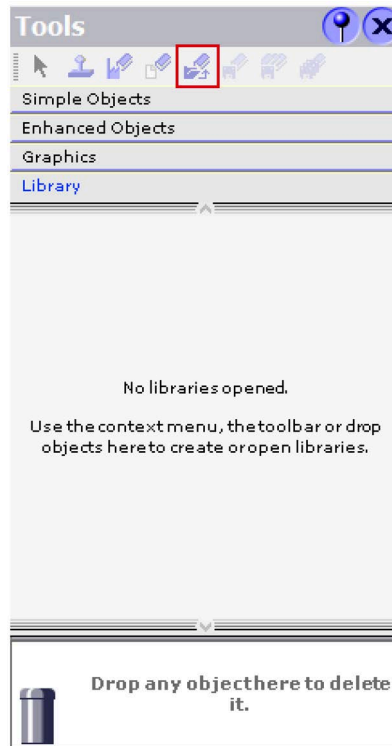

Figure 8-1

3. Click the "Look in:" drop-down list and browse to the stored location of the library "SITOP-UPS1600\_Library\_STEP7-V5\_V3-0 > UPS1600 V3-0 library WinCC flexible 2008" on your computer.

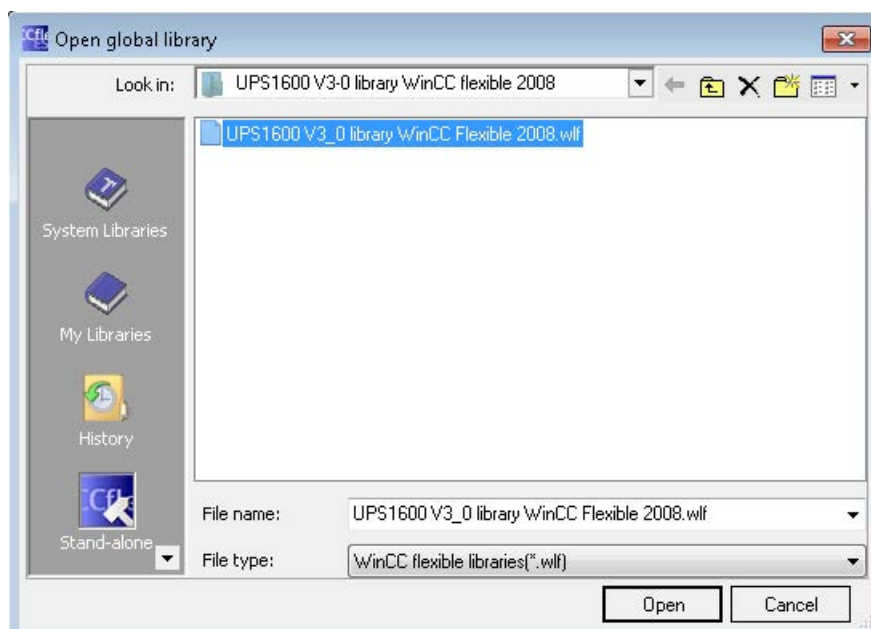

Figure 8-2

4. Select "UPS1600 V3\_0 library WinCC flexible 2008.wlf" and click "Open".  
This imports the library into your project.

## Inserting faceplates into a project

The following procedure describes how to integrate the faceplate from the library into an existing WinCC flexible project:

1. Open the required WinCC flexible project.
2. In the "Project" window, open the screen into which you want to insert the faceplate (Screen\_1).

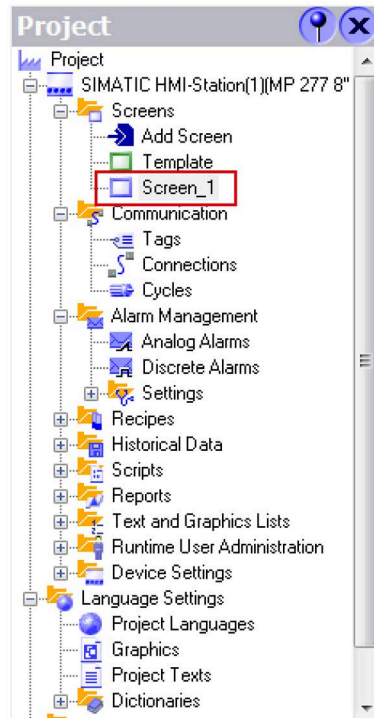

Figure 8-3

3. In the "Tools" window, under the "Library" tab, select the faceplate element "Faceplate\_UPS1600\_V3\_0".
4. Drag-and-drop "Faceplate\_UPS1600\_V3\_0" into the opened screen.

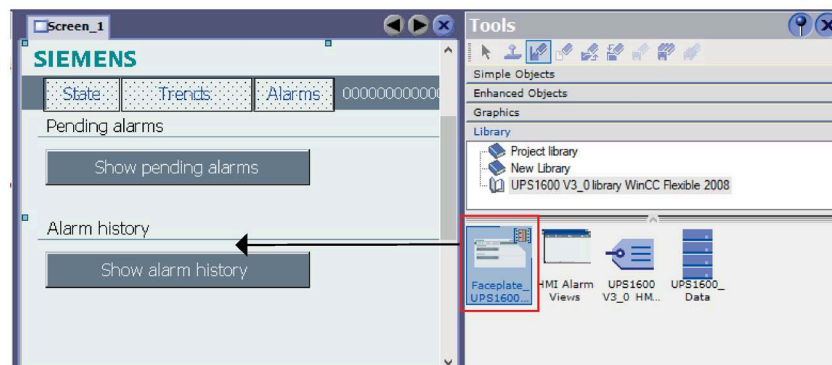

Figure 8-4

- In the "Project" window, select "Screens" and open "Template".

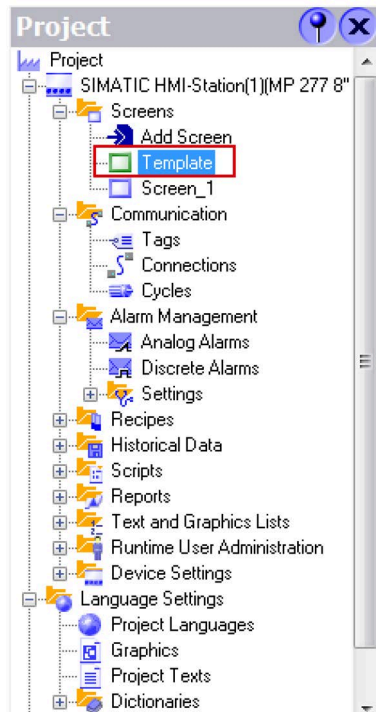

Figure 8-5

- In the "Tools" window, select the "HMI Alarm views" element of the library.
- Drag-and-drop "HMI Alarm views" into the template. Two message windows are inserted.

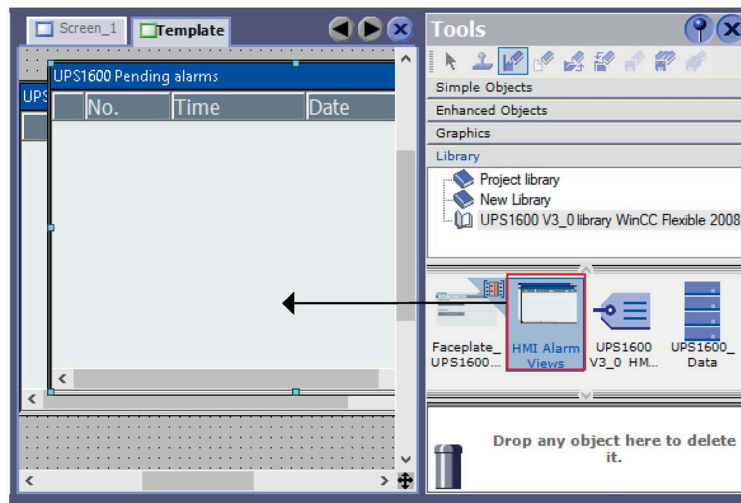

Figure 8-6

- Select "Alarmview\_UPS\_Pending" alarm window, right-click on the "Properties" and select "Properties > Display > Enable "ACK" button". Repeat the same procedure for enabling "ACK" button in "Alarmview\_UPS\_History" alarm window.
- In the "Project" window, select "Communication > Tags".

10. In the "Tools" window, select the "UPS1600 V3\_0 HMI tag table" library element.

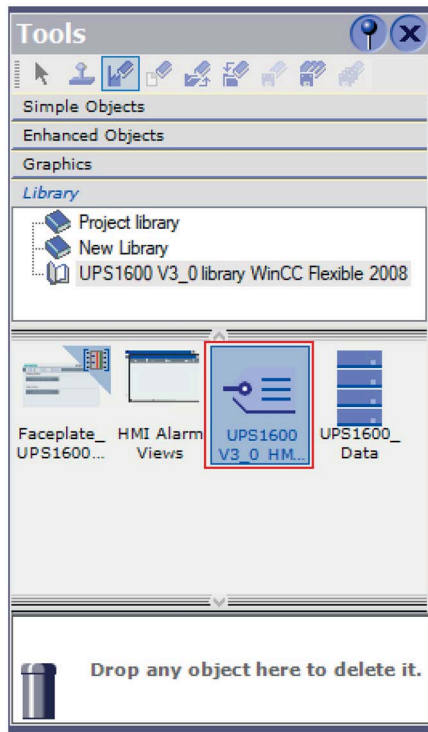

Figure 8-7

11. Drag-and-drop "UPS1600 V3\_0 HMI tag table" into the "Tags" folder.

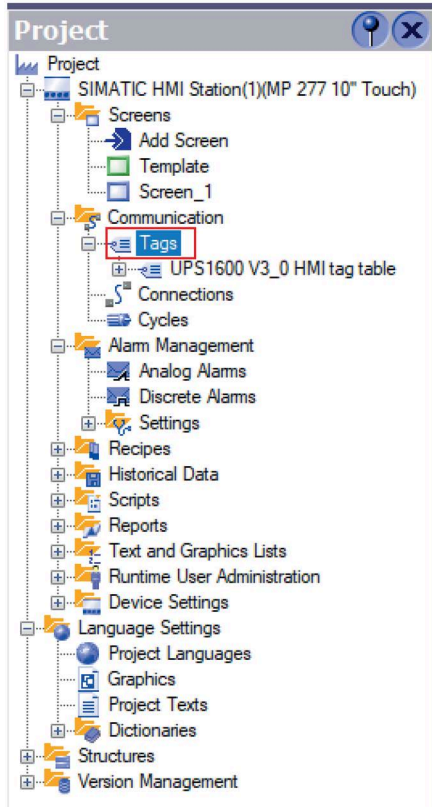

Figure 8-8

12. Open the tag table "UPS1600 V3\_0 HMI tag table", for the "UPS\_Data" tag,

- In the "Connection" column, select the required connection. (The connection name must be identical to the name of the connection created during configuring connection to the controller.)
- Assign the global DB "UPS\_Global" number to the tag (DB15).

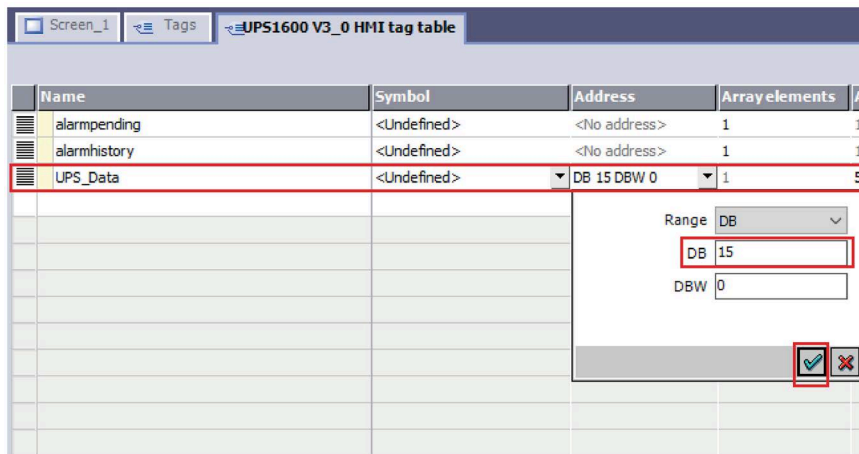

Figure 8-9



13. In the tag table, select the tag "alarmhistory". Check the properties of the tag where in the "ShowAlarmWindow" function is inserted and its variable "Object name" is assigned to the tag "Alarmview\_UPS\_History".

If the "Properties" window does not open then right click on the tag and go to "Properties".

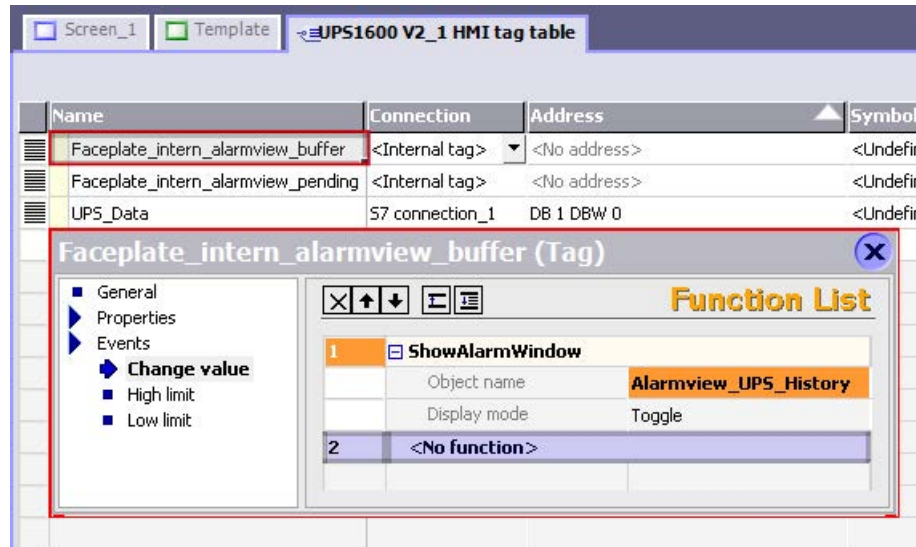

Figure 8-10

Similarly, check the properties of the tag "alarmpending" where in the "ShowAlarmWindow" function is inserted and its variable "Object name" is assigned to the tag "Alarmview\_UPS\_Pending".

If the "ShowAlarmWindow" function is not inserted for these two tags, refer to the section **Adding "ShowAlarmWindow" function to the tags** described below.

14. Select the faceplate inserted in step 4 (Screen\_1) and go to "Properties > Dynamic Interface".

15. Under the "Data" section, for the "UPS\_Data" property assign the "UPS\_Data" tag created in step 11.

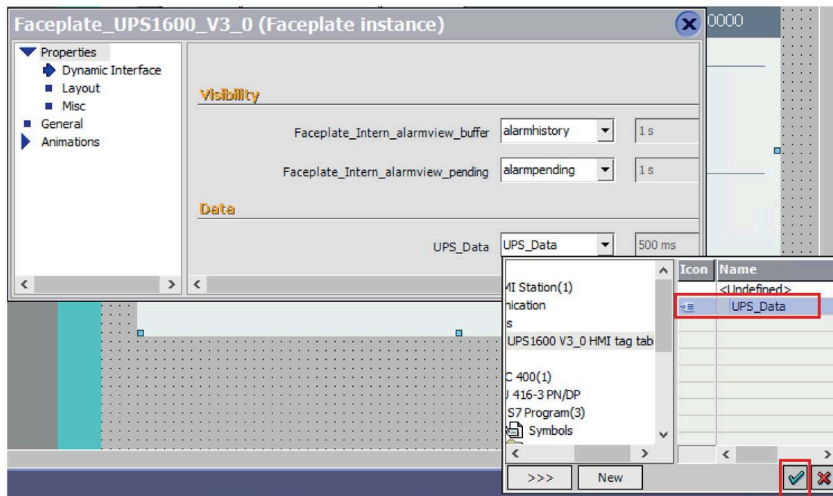

Figure 8-11

16. Under the "Visibility" section, for the "Faceplate\_intern\_alarmview\_buffer" property insert the "alarmhistory" tag from the "UPS1600 V3\_0 HMI tag table" tag table.

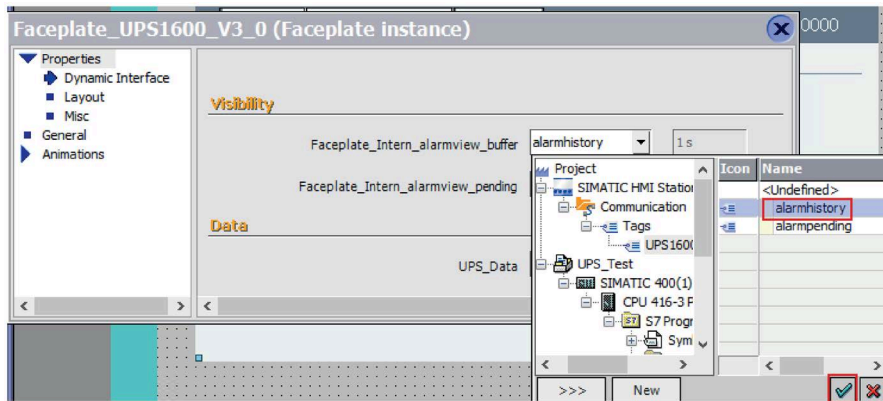

Figure 8-12

Similarly, for the "Faceplate\_intern\_alarmview\_pending" property insert the "alarmpending" tag from the "UPS1600 V3\_0 HMI tag table" tag table.

**Note**

**Connection in the UPS1600 V3\_0 HMI tag table**

A default connection is always created automatically when a project is created. Delete the default connection if you have created another connection for your project.

## Adding "ShowAlarmWindow" function to the tags

The following procedure describes how to add the "ShowAlarmWindow" function to "alarmpending" and "alarmhistory" tags in the "UPS1600 V3\_0 HMI tag table" tag table:

1. Select the "alarmhistory" tag. A new window opens.
2. Go to "Events > Change value".
3. Click on "<No function>".
4. In the drop-down list select "System functions > Alarms > ShowAlarmWindow".

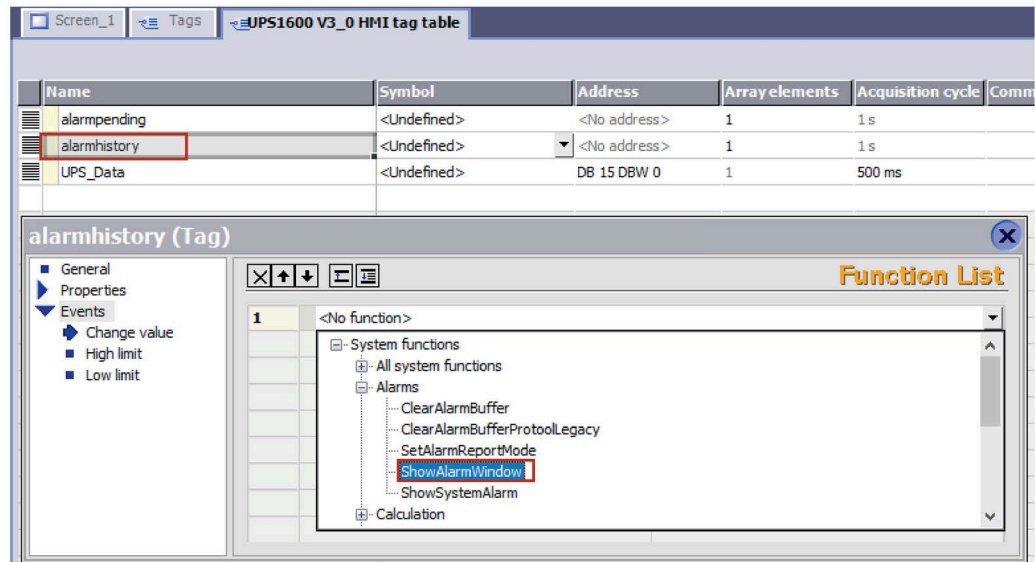

Figure 8-13

5. For the "Object name" variable click on "<No value>".
6. In the drop-down list select "Alarmview\_UPS\_History".

Follow the same procedure for the "alarmpending" tag, add "ShowAlarmWindow" function and select "Alarmview\_UPS\_Pending" for the "Object name" variable.

## Displaying the PROFINET diagnostic messages

To display the PROFINET diagnostic messages of UPS1600 within the faceplate, the respective WinCC flexible project must already be configured.

Information on the display and configuration of diagnostic messages in WinCC flexible is available in the entry ID 22319131

(<https://support.industry.siemens.com/cs/ww/en/view/22319131>).

Further notes regarding the PROFINET diagnostic messages of the SITOP UPS1600 are available in the chapter 4 of the SITOP UPS1600 User Manual

(<https://support.industry.siemens.com/cs/ww/en/view/84977415>).

### Connecting trends of the faceplates with data sources

The following procedure describes how to create and connect trends to a faceplate:

1. Open WinCC project and select "Communication > Tags > UPS1600 V3\_0 HMI tag table" and open the tag table.

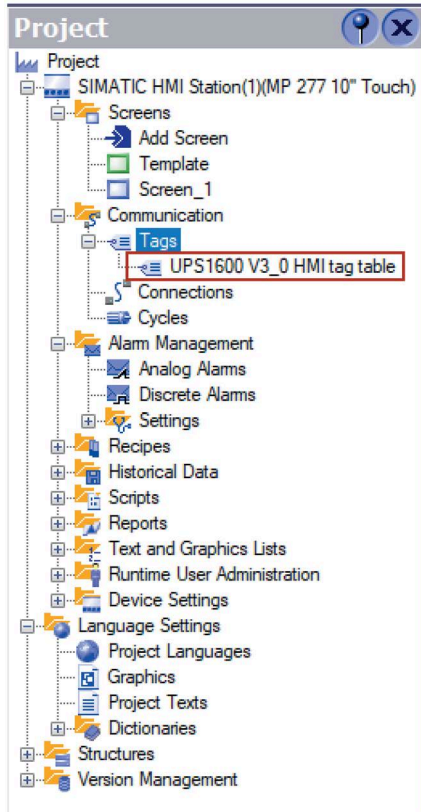

Figure 8-14

2. In the tag table, create a new tag.

In the "Symbol" column, click the drop down box, navigate to the global DB tag created in the project (UPS\_Global) and select "inputVolt" tag. (Here, select "Project > UPS\_Test > SIMATIC 400(1) > CPU 416-3PN/DP > S7 Program(3) > DB > UPS\_Global > UPS > inputVolt".)

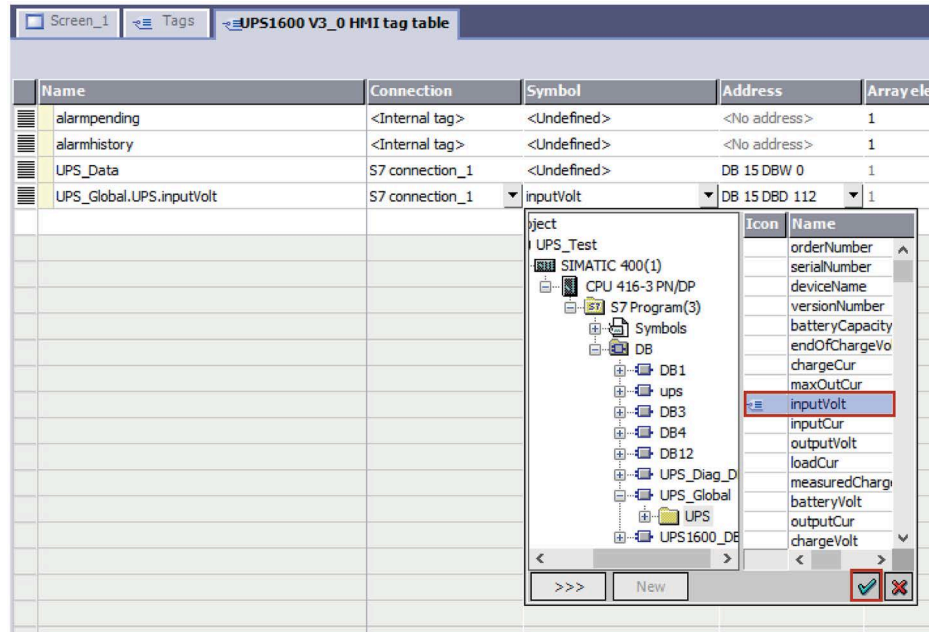

Figure 8-15

3. Repeat step 2 to create four more tags and assign the following symbols:

- outputVolt
- outputCur
- batteryVolt
- measuredChargeCur

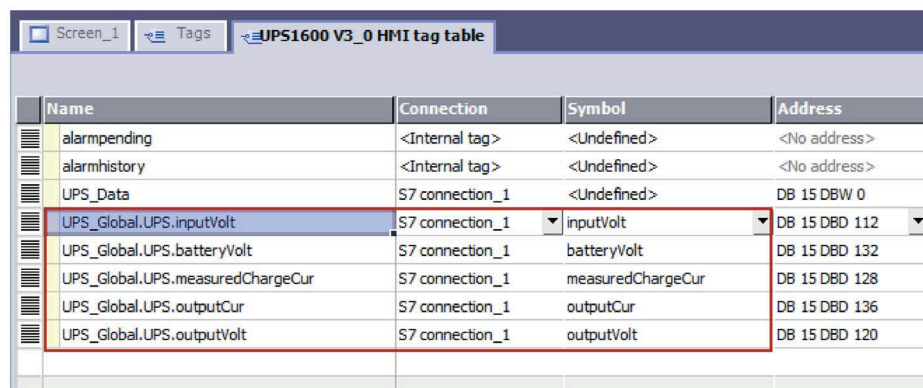

Figure 8-16

4. Select the faceplate in your screen and go to "Properties > General".

5. Under the "Trends" section, select the "Trends" variable to add trends to the faceplate. A new window appears.

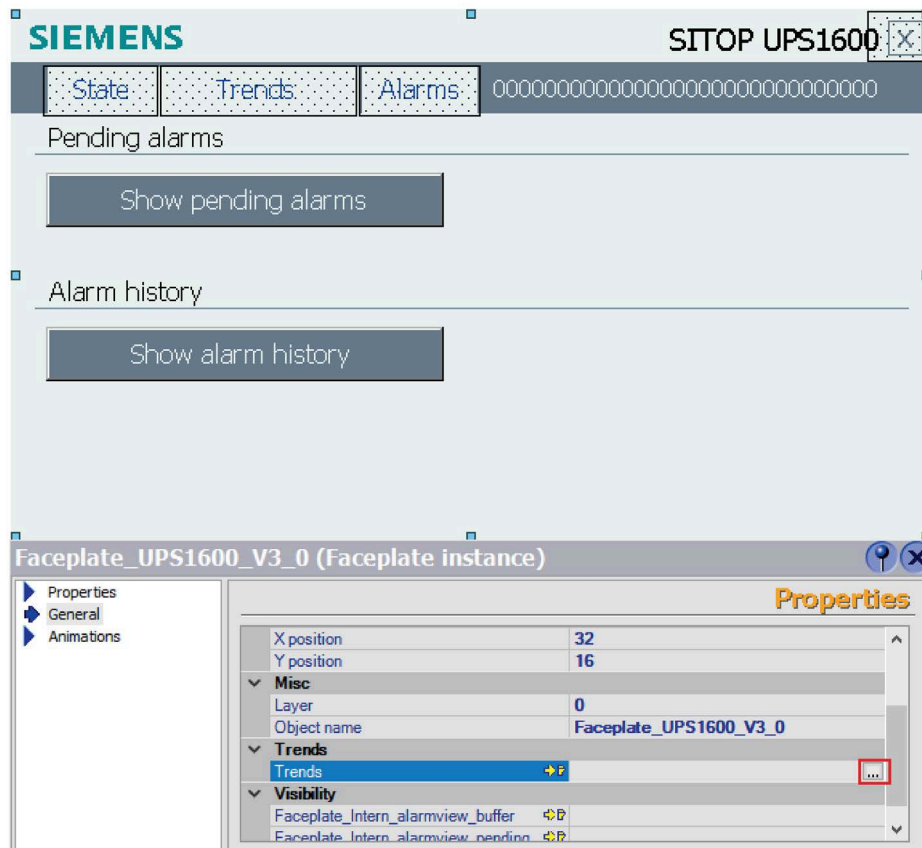

Figure 8-17

6. In the window, add five trends.
  - In the "Samples" column, enter 600 points for the trend representation.
  - For "Trend type", select "Realtime Cyclic Triggered".

- In the "Source settings" column, for each of the trends assign the data sources in the "Trend tag" variable:  
Trend 1: inputVolt  
Trend 2: outputVolt  
Trend 3: outputCur  
Trend 4: batteryVolt  
Trend 5: measuredChargeCur

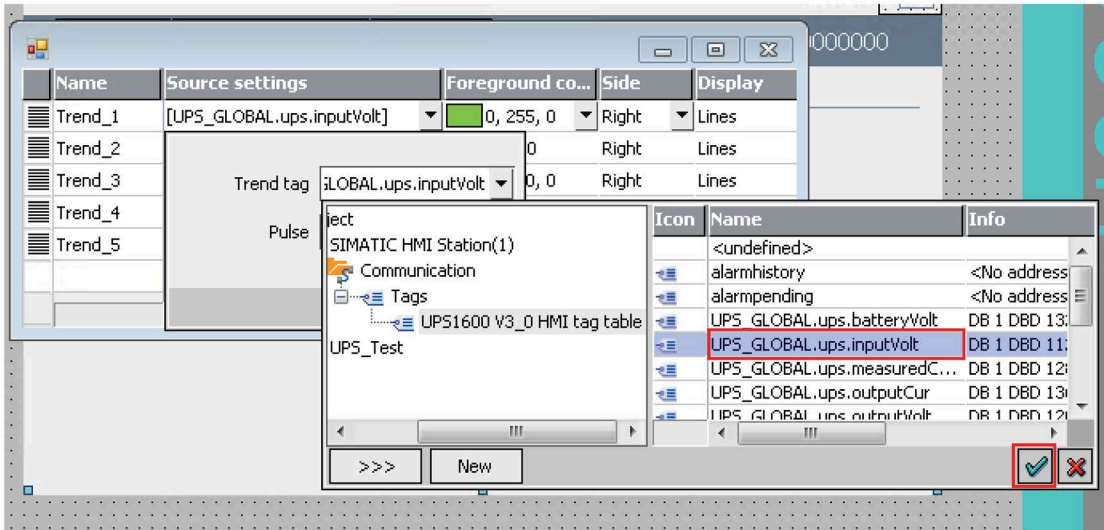
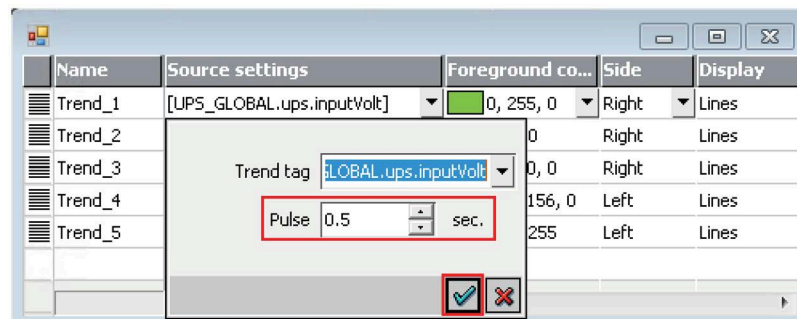

Figure 8-18

Also, set the "Pulse" value to 0.5 s for each of the trends.



- In the "Foreground color" column, select the trend colors for the individual outputs according to the legend.

Trends

- Input voltage
- Charge current
- Battery voltage
- Output current
- Output voltage

- In the "Side" column, select the side as "Right" for voltage related tags (Volts scale) and "Left" for current related tags (Ampere scale).

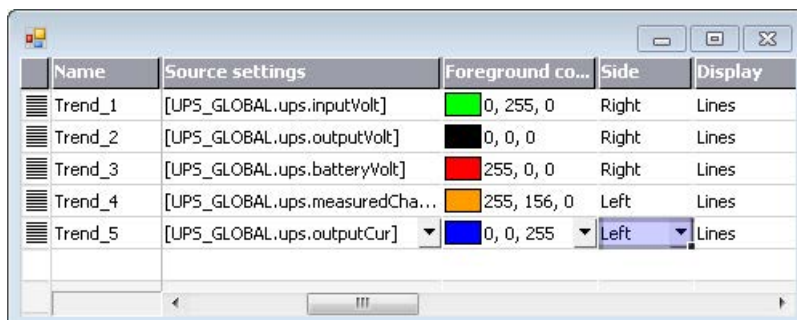

The screenshot shows a configuration table with five rows of trend tags. The columns are Name, Source settings, Foreground co..., Side, and Display. The 'Side' column is highlighted, showing 'Right' for voltage-related tags and 'Left' for current-related tags.

Name	Source settings	Foreground co...	Side	Display
Trend_1	[UPS_GLOBAL.ups.inputVolt]	0, 255, 0	Right	Lines
Trend_2	[UPS_GLOBAL.ups.outputVolt]	0, 0, 0	Right	Lines
Trend_3	[UPS_GLOBAL.ups.batteryVolt]	255, 0, 0	Right	Lines
Trend_4	[UPS_GLOBAL.ups.measuredCha...]	255, 156, 0	Left	Lines
Trend_5	[UPS_GLOBAL.ups.outputCur]	0, 0, 255	Left	Lines



## 8.2 Application of screen windows in WinCC V7.4

### 8.2.1 Prerequisites

#### Requirements

The following requirements must be met to use the screen windows in WinCC V7.4:

- The GSD file of the SITOP UPS1600 is installed in SIMATIC STEP 7 V5.6 and the UPS is configured as PROFINET node in the HW configuration of the CPU.
- S7 communication between the SITOP UPS1600 and CPU is already configured.
- All program blocks from the library UPS1600 V3\_0 STEP7 V5\_6 are integrated into STEP 7 application program and executable.
- The library UPS1600 V3-0 library WinCC V7.4 is available on your computer.
- Existing WinCC OS (PC station) with already configured connection and active communication.

#### PC Station

The screen windows are supported for the following PC Station:

- WinCC V7.4 Runtime

#### Supported languages

The screen windows support the following languages:

- English (USA)
- German (Germany)
- Chinese (PR China)

## 8.2.2 Library for WinCC V7.4

### Library for WinCC V7.4

The library UPS1600 V3-0 library WinCC V7.4 for WinCC V7.4 comprises the following file folders:

Table 8- 2

Name	Type	Description
HMI Tag table (WinCC V7.4)	Tags	File for tag import
HMI Screens (WinCC V7.4)	Screens	Comprises screen 'UPS1600_V3_0.pdl'

### HMI Tag table (WinCC V7.4)

This folder contains the file UPS1600\_HMIUDT.txt. This text file comprises all the tags and structure required for the functioning of UPS1600 screens.

### HMI Screens (WinCC V7.4)

This folder contains the screen UPS1600\_V3\_0.pdl.

## 8.2.3 Integrating the screen windows

### Overview

Target system used:

- WinCC V7.4 Runtime

### Inserting the project screens

The following procedure describes how to insert the HMI screen from the library into the project directory of your WinCC project:

1. Open "Windows Explorer" in your computer machine and navigate to the "GraCS" folder in your project directory. Here, path to the folder is: "C:\Program Files(x86)\SIEMENS\STEP7\S7Proj\Ups1600\wincproj\OS(2)\GraCS".
2. Open another instance of "Windows Explorer" in your computer machine and navigate to the stored location of the "SITOP-UPS1600\_Library\_STEP7-V5\_V3-0" library folder.
3. In the library folder, open "UPS1600 V3-0 library WinCC V7.4".
4. Copy the "UPS1600\_V3\_0.pdl" screen element from the library and paste it into the "GraCS" folder.

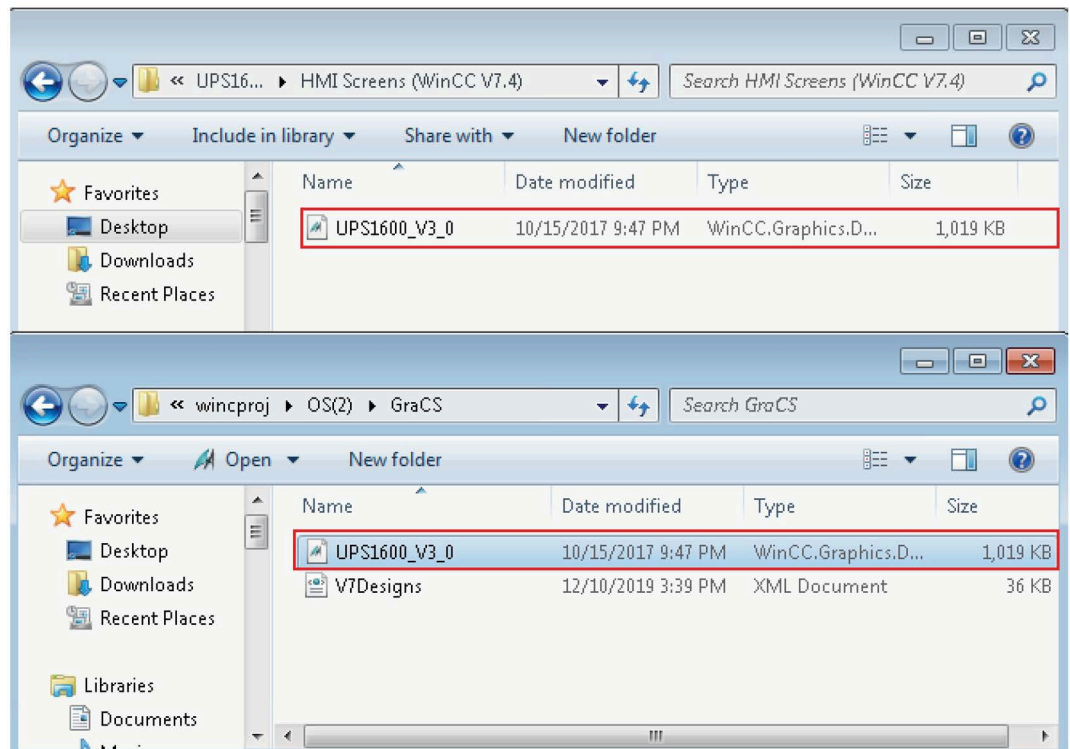

Figure 8-19

## Importing tags

The following procedure describes how to import the HMI tag table file from the library folder into your WinCC project:

1. Open your WinCC project in WinCC Explorer.
2. Open the "Tag Management" element. The "Tag Management – WinCC Configuration Studio" window opens.

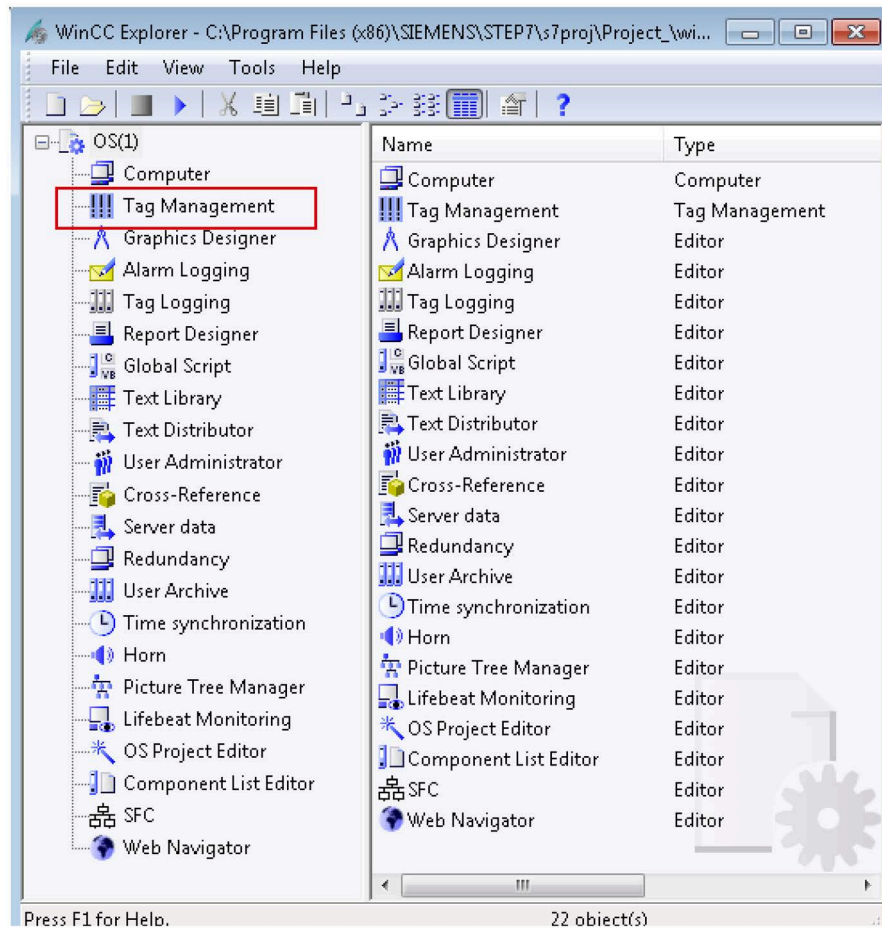

Figure 8-20

3. In the "Tag Management" window, select "Structure tags".

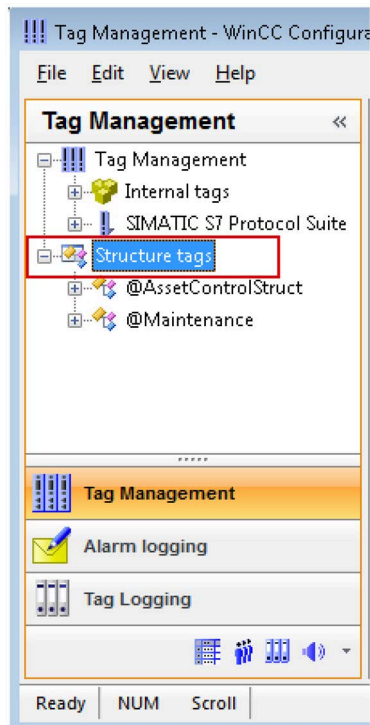

Figure 8-21

4. In the menu bar, select "Edit > Import". The "Import" window opens.
5. Browse to the stored location of "SITOP-UPS1600\_Library\_STEP7-V5\_V3-0" library folder in your machine and open "UPS1600 V3-0 library WinCC V7.4 > HMI Tag table (WinCC V7.4)".

6. Select "UPS1600\_HMIUDT".

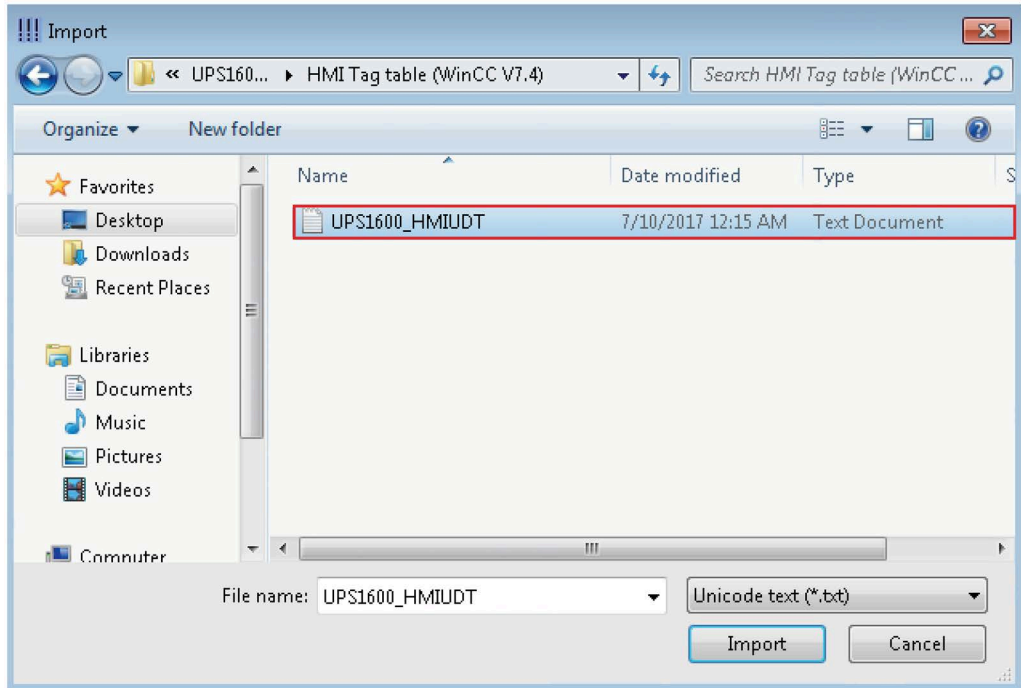

Figure 8-22

7. Click "Import". "UPS1600\_Data" structure tag element appears under "Structure tags" in "Tag Management" window.

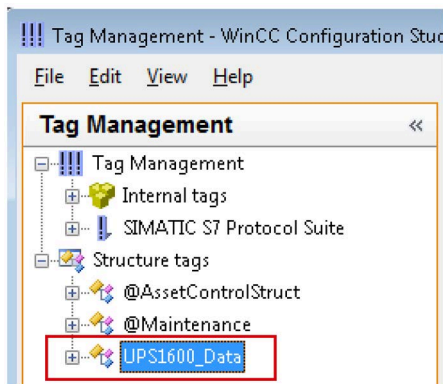

Figure 8-23

8. Close the window.

## Configuring screen windows

The following procedure describes how to configure a screen window:

1. In the WinCC project, select "Graphics Designer".
2. On its right window pane, right click on the empty space and select "New picture" option to add a new pdl file.

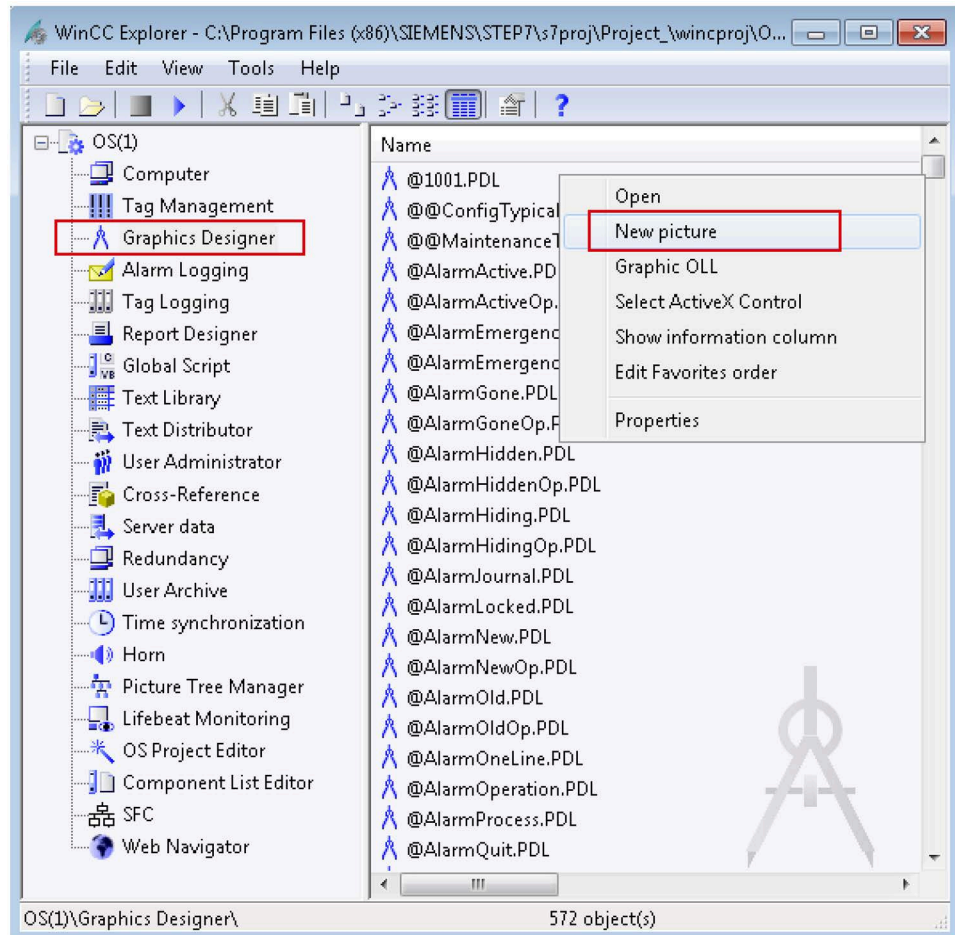

Figure 8-24

3. Rename the pdl created in step 2 as required (UPS\_ScreenWindow) and open it. The "Graphics Designer" window opens.
4. In the "Standard" window of the Graphics Designer go to "Smart Objects" folder and select "Picture Window".

- Click on the "UPS\_ScreenWindow.pdl" screen area to insert the "Picture Window".

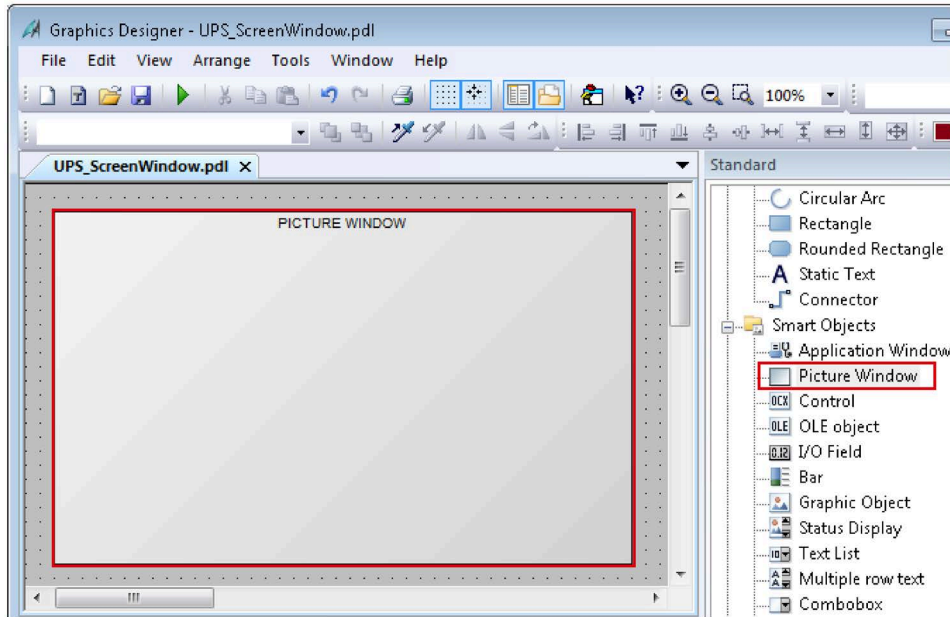

Figure 8-25

- Select the added screen window and go to "Properties > Miscellaneous".
- For the "Picture Name" attribute assign "UPS1600\_V3\_0.pdl" and for the "Tag Prefix" attribute assign the tag "UPS\_Global" created during importing the HMI tag table (refer to STEP 7 in Configuring Screen windows procedure). If your structure tag name is 'StructureTag' then add a '.' at the end of your tag name, that is 'StructureTag.' (<Structure tag name>.). Here, "UPS\_Global."

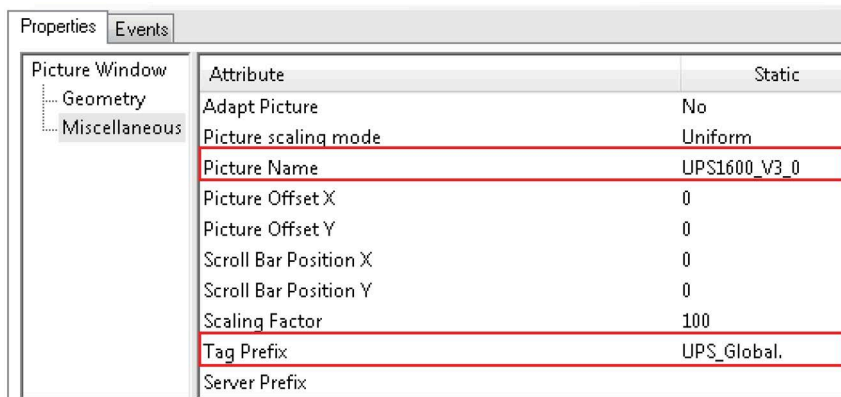

Figure 8-26



## Displaying the PROFINET diagnostic messages

In order to display the PROFINET diagnostic messages of the SITOP UPS1600 within the screen windows, the respective WinCC project must already be configured for the display of PROFINET diagnostic messages.

Information on the display and configuration of diagnostic messages in WinCC is available under the entry ID 23730649

(<https://support.industry.siemens.com/cs/ww/en/view/23730649>).

Further notes regarding the PROFINET diagnostic messages of the SITOP UPS1600 are available in the chapter 4 of the SITOP UPS1600 User Manual

(<https://support.industry.siemens.com/cs/ww/en/view/84977415>).

## 8.2.4 Application of screen windows in WinCC V7.5

### 8.2.4.1 Overview

To work with the library in WinCC V7.5 follow the similar process as mentioned in Application of screen windows in WinCC V7.4 (Page 85), except opening the library UPS1600 V3-0 library WinCC V7.5 in place of UPS1600 V3-0 library WinCC V7.4.

## 8.3 Application of faceplates in WinCC Comfort/Advanced V15.1

### 8.3.1 Prerequisites

#### Requirements

The following requirements must be met to use the faceplates in WinCC Comfort/Advanced V15.1 and WinCC Comfort/Advanced V16:

- The HSP for the SITOP UPS1600 is installed in STEP 7 V15.1.
- S7 communication between SITOP UPS1600 and SIMATIC S7 controller is already configured.
- Program blocks for STEP 7 V15.1 from LUPS1600 are integrated into the application program and executable.
- LUPS1600 is available on your computer.

#### Supported control panels

The faceplates are supported for the following control panels:

- TP700 Comfort/KP700 Comfort
- TP900 Comfort/KP900 Comfort
- TP1200 Comfort/KP1200 Comfort
- TP1500 Comfort/KP1500 Comfort
- TP1900 Comfort
- TP2200 Comfort
- MP277 8" Touch/MP277 8" Key
- MP277 10" Touch/MP277 10" Key
- MP377 Touch/Key
- WinCC RT Advanced V15.1

#### Supported languages

The faceplates support the following languages:

- English (USA)
- German (Germany)
- Chinese (PR China)

## 8.3.2 Library for WinCC Comfort/Advanced

### Library for WinCC Comfort/Advanced

The following objects are part of LUPS1600 for WinCC Comfort/Advanced:

Name	Type	Description
Comfort/Advanced	Faceplate from Types folder	Comprises of "LUPS1600_FpRTAdv" faceplate and "LUPS1600_type300400RTAdv" HMI UDT
TagTablesRTAdv	Tag folder from Master copies	Comprises LUPS1600_TagTableS7300400RTAdv and LUPS1600_TagTableS712001500RTAdv
AlarmWindows	Alarm views from Master copies	Comprises 'Alarm windows' screen that has two message windows to display the PROFINET diagnostic messages of the UPS1600.

## 8.3.3 Integrating the faceplates

### Overview

Hardware used:

- TP900 Comfort

An overview of the supported HMI control panels is available in the Precondition (Page 94).

### Opening the library in WinCC V15.1

The procedure for opening the library in WinCC Professional V15.1 is explained in the Content of the library for STEP 7 V15.1 (Page 49).

### Inserting faceplates into a project

The following procedure describes how to integrate the faceplates from LUPS1600 into an existing WinCC project:

1. Open the required project in "Project view".
2. In the "Project tree", open the "Screens" folder.

3. Double click on "Add new screen" to add a new screen into your project.

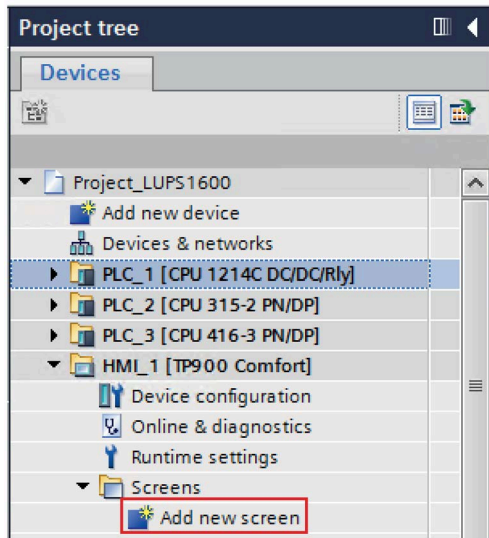

Figure 8-27

Open the new screen (Screen\_1).

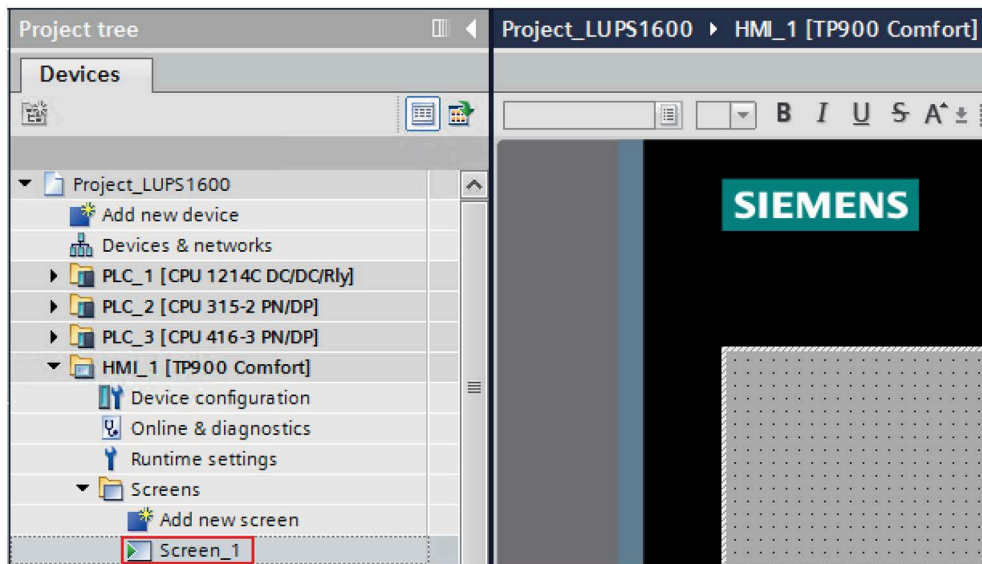

Figure 8-28

4. In the "Libraries" window, select "Global libraries > LUPS1600 > Types > LUPS1600 > WinCC > Comfort/Advanced > LUPS1600\_FpRTAdv".

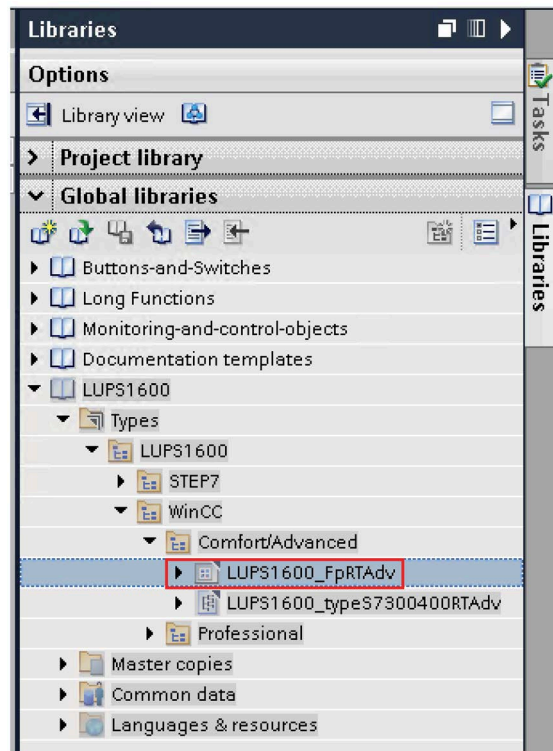

Figure 8-29

5. Drag-and-drop "LUPS1600\_FpRTAdv" into the opened screen in step 3.

### Creating a connection to the data block for global data exchange

The following procedure describes how to create a connection to the data block for global data exchange:

1. In the "Libraries" window, select "Global libraries > LUPS1600 > Master copies > LUPS1600 > WinCC > Comfort/Advanced > TagTablesRTAdv > LUPS1600\_TagTableS712001500RTAdv".

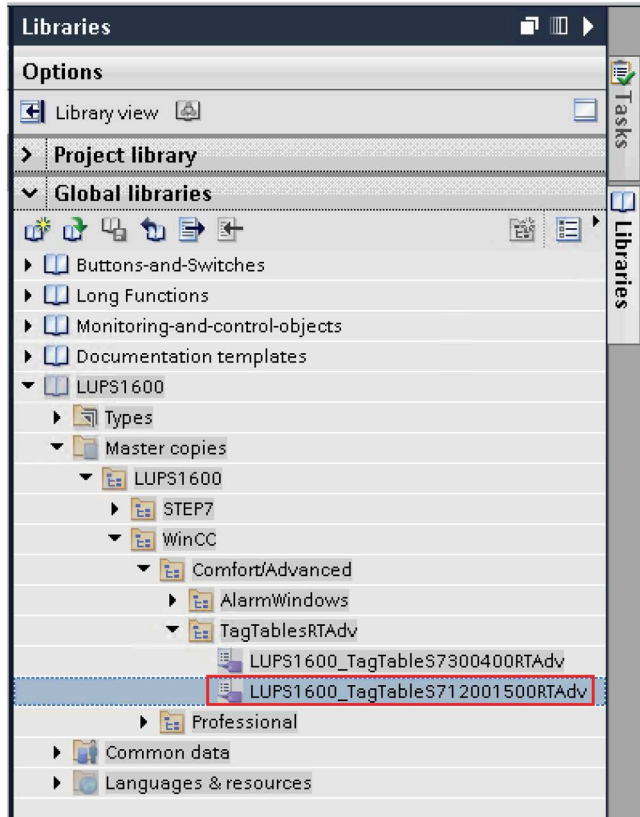

#### Note

##### S7-300/400 PLC

For S7-300/400 PLCs, select "LUPS1600\_TagTableS7300400RTAdv" instead of "LUPS1600\_TagTableS712001500RTAdv".

2. Drag-and-drop "LUPS1600\_TagTableS712001500RTAdv" into the "HMI tags" folder in the "Project tree".

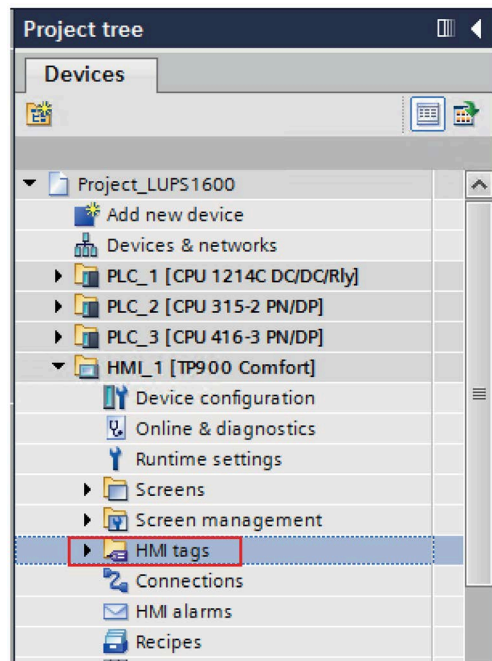
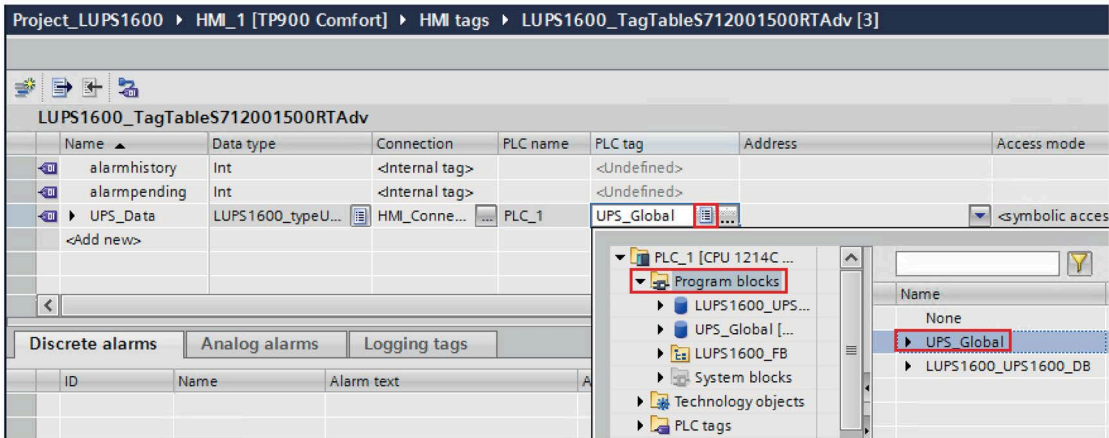

Figure 8-30

3. Open "LUPS1600\_TagTableS712001500RTAdv" in the "HMI tags" folder.

- For the "UPS\_Data" tag, set the global DB (UPS\_Global) created in Procedure when using an S7-1200/1500 (Page 63) from the Program blocks.



**Note**

**For 300/400 PLCs,**

- For the "UPS\_Data" tag, make sure:
  - the "Connection" is set to "HMI\_Connection\_1".
  - the global DB number in the "Address" column is set to 2.

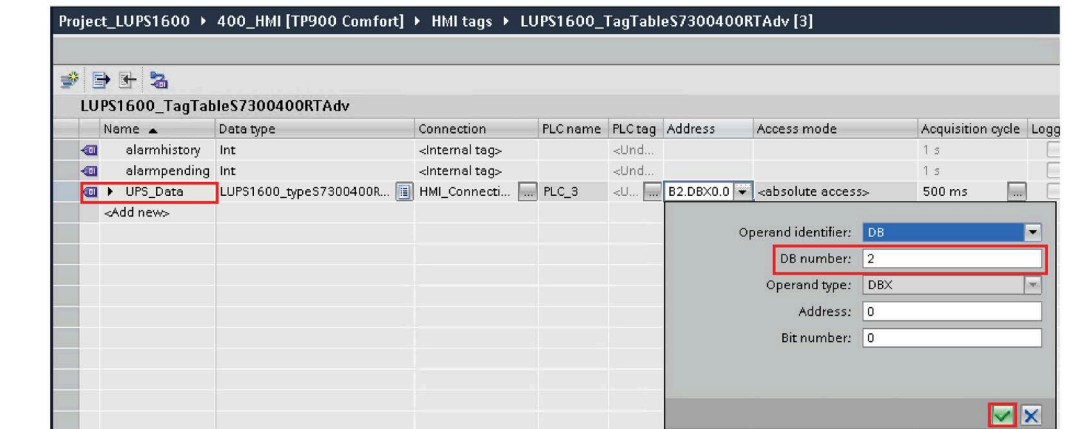



5. Select the "UPS\_Data" tag and go to "Properties > Properties > Settings" and make sure:
  - the "Acquisition mode" is set to "Cyclic continuous".
  - the "Acquisition cycle" value is set to "500 ms".

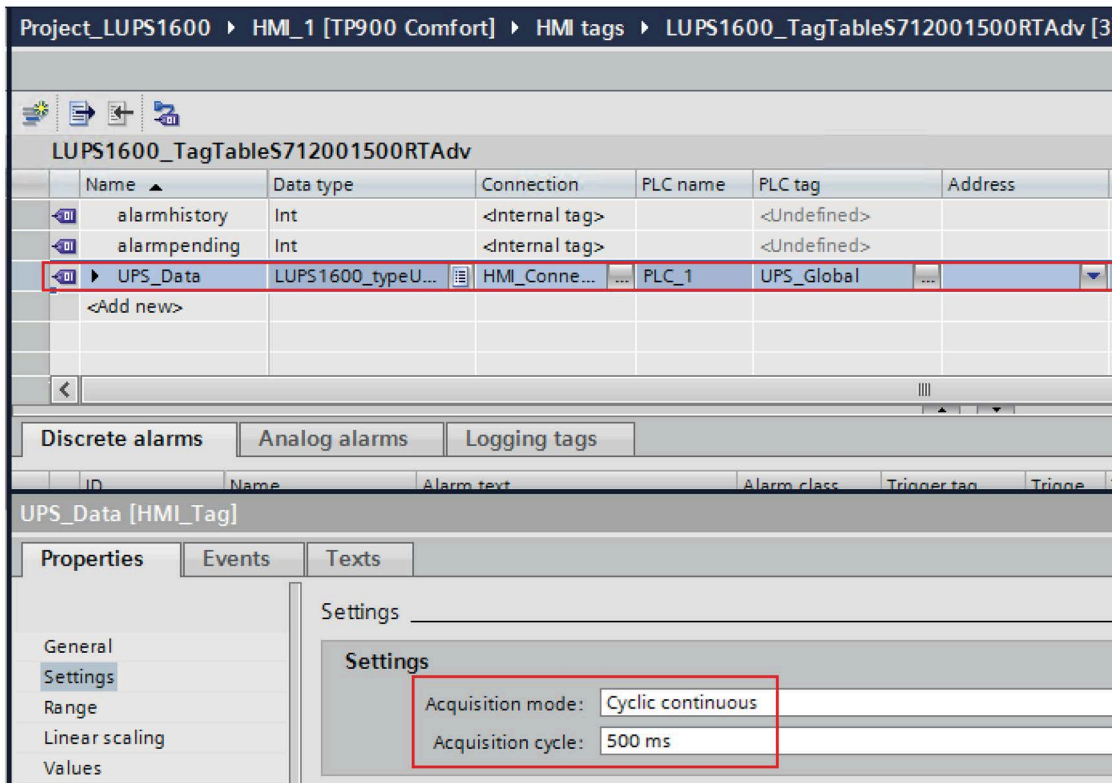

Figure 8-31

6. In the "Project tree", open the screen with the inserted faceplate (Screen\_1).
7. Select the faceplate on the screen in the display area and go to "Properties > Interface > Data".

8. Select the "UPS1600Data\_S71200/1500" property and connect the "UPS\_Data" tag in "LUPS1600\_TagTableS712001500RTAdv" under the "Dynamization" column.

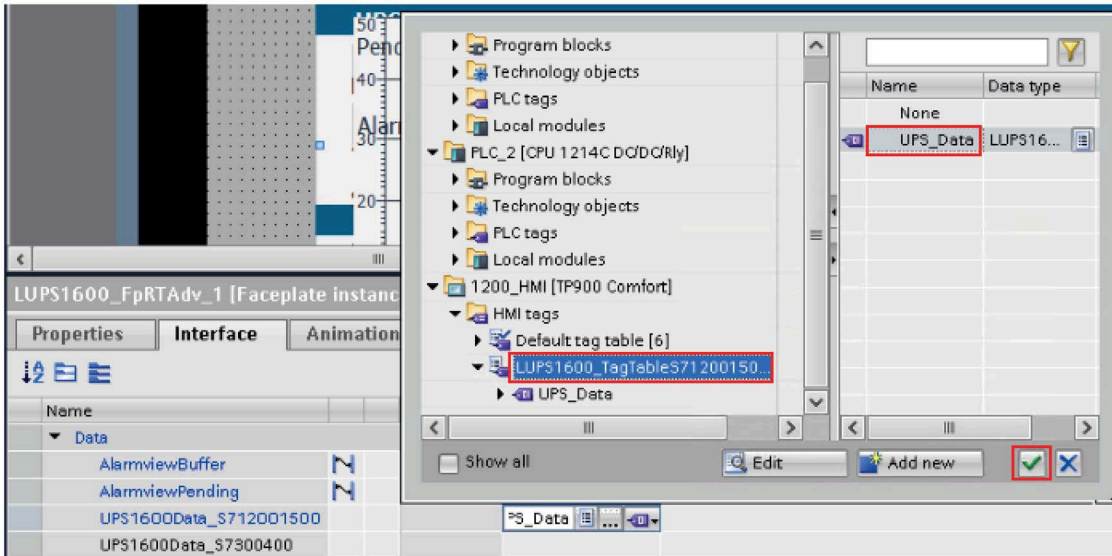
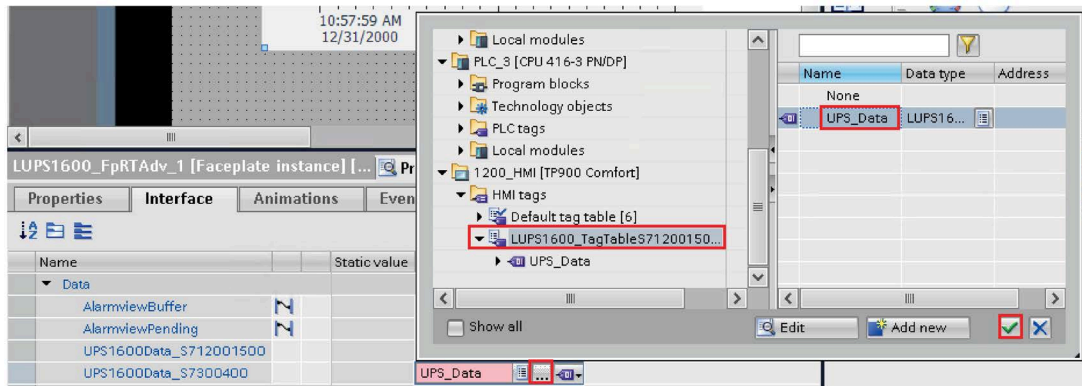

Figure 8-32

9. In a similar way, select the "UPS1600Data\_S7300/400" property and connect the same "UPS\_Data" tag in "LUPS1600\_TagTableS712001500RTAdv" under the "Dynamization" column.



**Note**

- When the user performs the above operation, a red mark appears. It is not an error. It means that the red marked property is not connected with the HMI. For example, in the above case, the red mark indicates that the HMI control panel is connected with a 1200/1500 PLC and not with a 300/400 PLC.
- For S7-300/400 PLCs or S7-1200/1500 PLCs, the tags UPS1600Data\_S7300400 and UPS1600Data\_S712001500 have to be mapped with the tag "UPS\_Data" without fail.

LUPS1600_FpRTAdv_1 [Faceplate instance] [LUPS1600_FpRTAdv V 3.0]						
Properties		Interface		Animations	Events	Texts
Name				Static value	Dynamization	
▼ Data						
AlarmviewBuffer					alarmhistory	
AlarmviewPending					alarmpending	
UPS1600Data_S712001500					UPS_Data	
UPS1600Data_S7300400					UPS_Data	

**Connecting trends of the faceplate with data sources**

The following procedure describes how to connect the trends of the faceplate with data sources:

1. In the "Project tree", open the screen with the inserted faceplate (Screen\_1).
2. Select the faceplate and go to "Properties > Interface > Trends".
3. Select "Trends" and click on the marked area in the "Static value" column to open the settings for the trends of the UPS1600 module.

LUPS1600_FpRTAdv_1 [Faceplate instance] [LUPS1600_FpRTAdv V 3.0.0]						
Properties		Interface		Animations	Events	Texts
Name				Static value	Dynamization	
▶ Data						
▼ Trends						
Trends						
				Trend_1		

Figure 8-33

The "Trend" window opens.

4. In the "Trend" window, add five trends in the "Name" column.
5. Set the "Trend value" to 600 to all the five trends.
6. In the "Source settings" column, click the drop-down. "Data source" dialog box opens.

7. For the "Process values" click on the highlighted area to navigate to the HMI tags and assign the following tags to each of the trends
  - inputVolt
  - outputVolt
  - outputCur
  - batteryVolt
  - measuredChargeCur

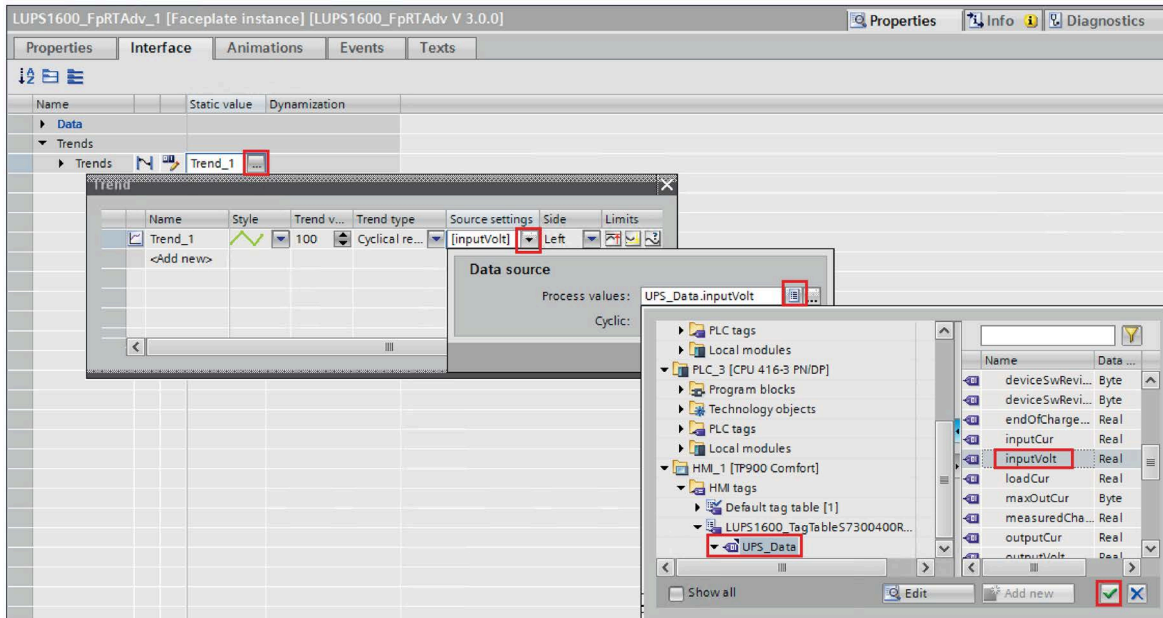

Figure 8-34

8. Set the "Cyclic" value to 0.5.

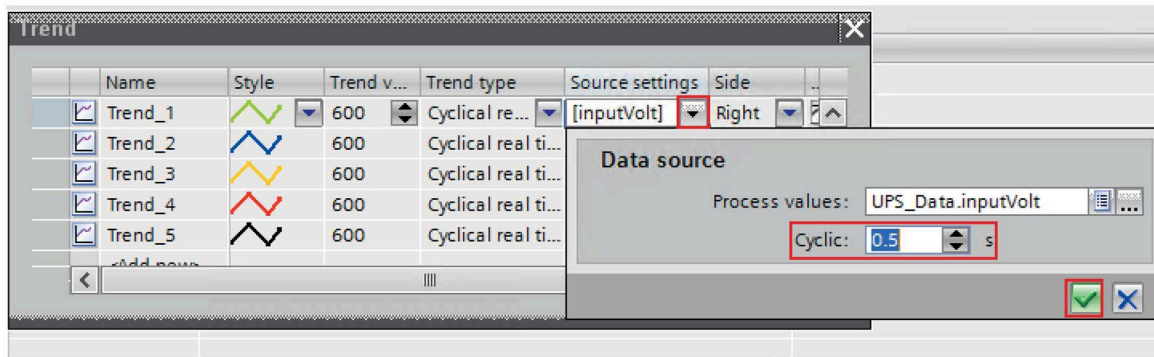

Figure 8-35

9. In the "Style" column, select the trend color for the individual trends according to the legend given below.

- UPS Input voltage
- UPS Output voltage
- UPS Output current
- Battery voltage
- Battery charge current

Figure 8-36

10. In the "Side" column, select the value as "Right" to voltage tags and select the value as "Left" to current tags assigned for the trends in step 6.

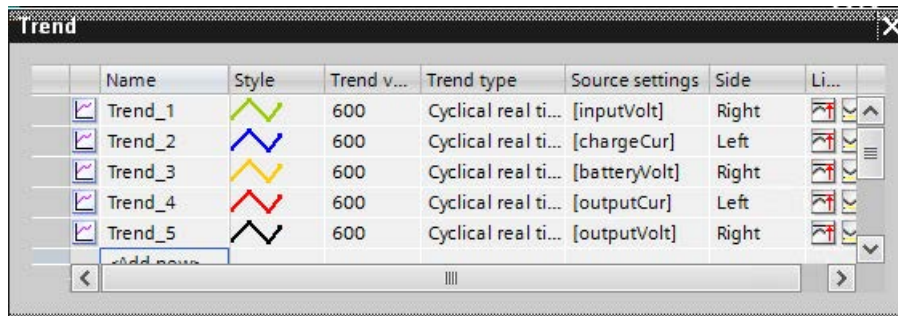

Name	Style	Trend v...	Trend type	Source settings	Side	Li...
Trend_1		600	Cyclical real ti...	[inputVolt]	Right	
Trend_2		600	Cyclical real ti...	[chargeCur]	Left	
Trend_3		600	Cyclical real ti...	[batteryVolt]	Right	
Trend_4		600	Cyclical real ti...	[outputCur]	Left	
Trend_5		600	Cyclical real ti...	[outputVolt]	Right	

Figure 8-37

### Activating the alarms display

1. In the "Project tree", double click on "Runtime settings" and select "Alarms".

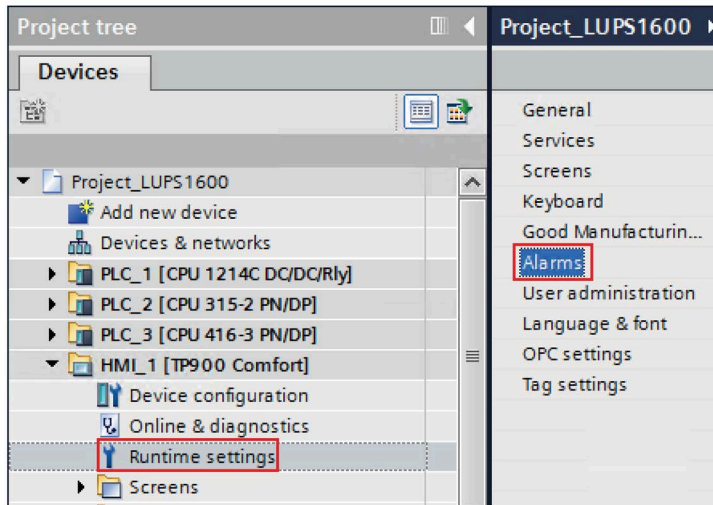

Figure 8-38

2. Check the options "S7 diagnostic alarms" and "With event text".

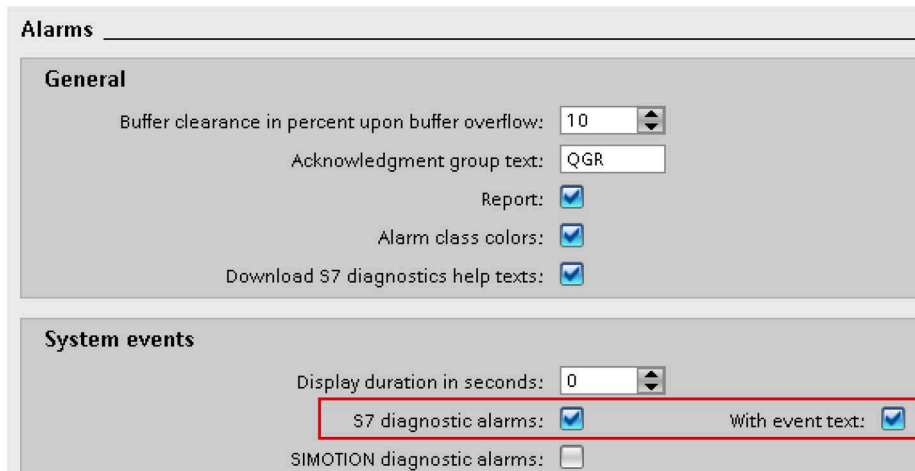

Figure 8-39

#### Note

When configuring an S7-300/400 controller in TIA Portal, you also need to activate the S7 diagnostic alarm on the controller side.

The following entry describes how to proceed: 62121503

(<https://support.industry.siemens.com/cs/ww/en/view/62121503>), see Chapter 3.2.2

'Configuring CPU system diagnostic alarms', description 'Settings in STEP 7 Professional'.

## Configuring the alarms display

1. In the "Libraries" window, select "Global libraries > LUPS1600 > Master copies > LUPS1600 > WinCC > Comfort/Advanced > AlarmWindows > LUPS1600\_AlarmWindowsRTAdv".

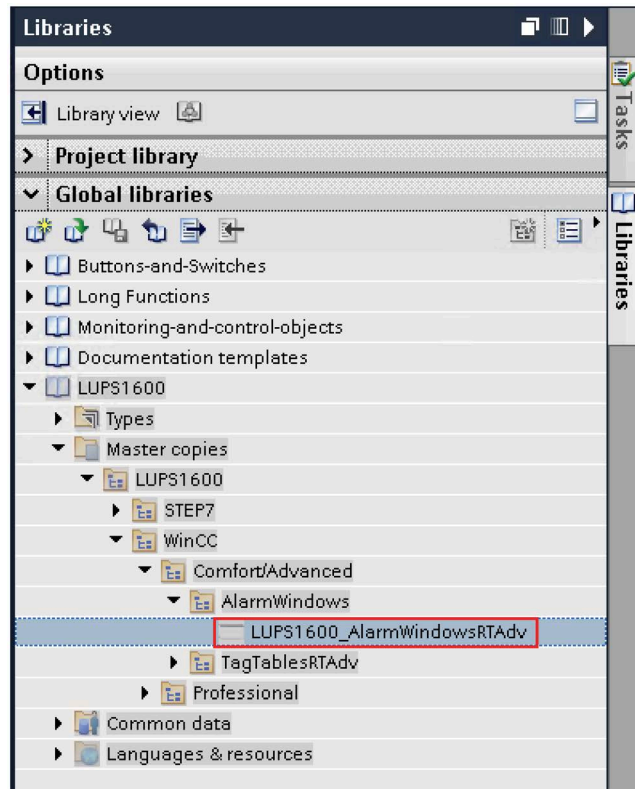



2. In the "Project tree", select "Screen management" and open "Global screen".

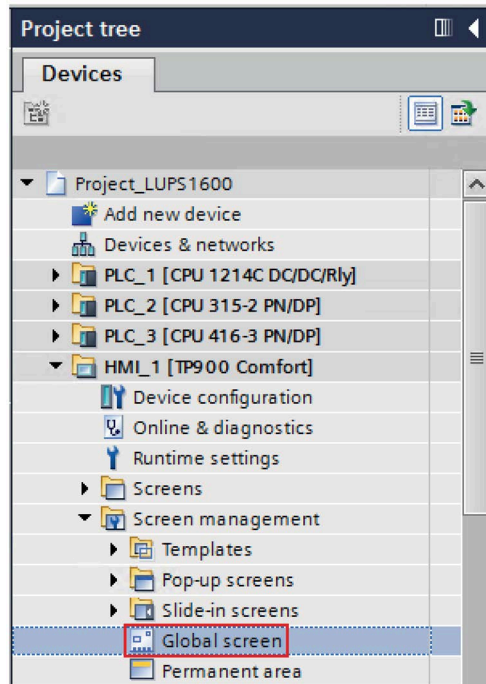

Figure 8-40

3. Drag-and-drop "LUPS1600\_AlarmWindowsRTAdv" into the global screen.

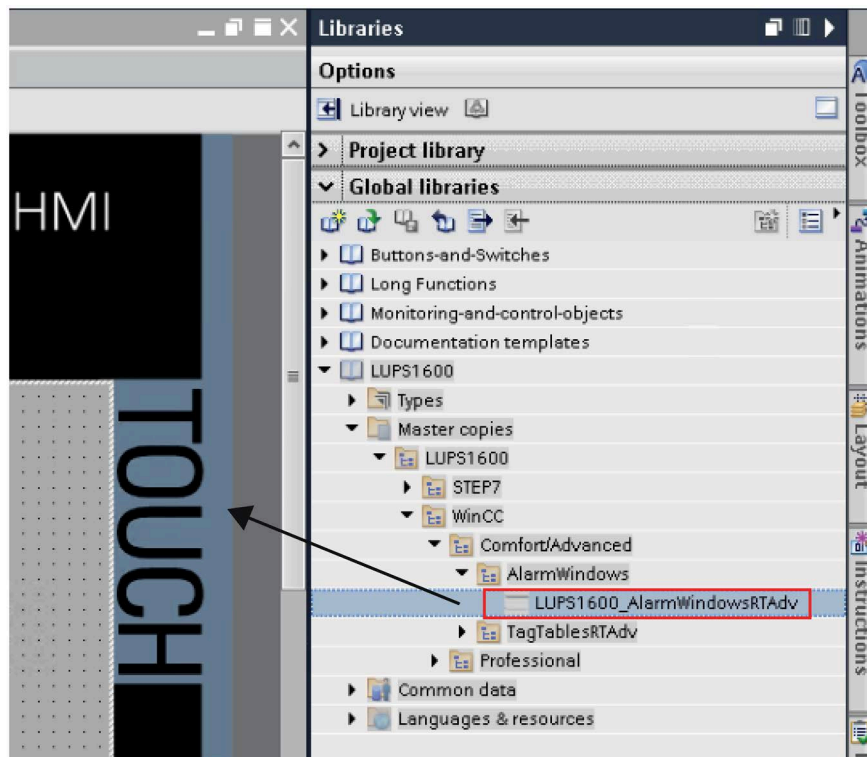
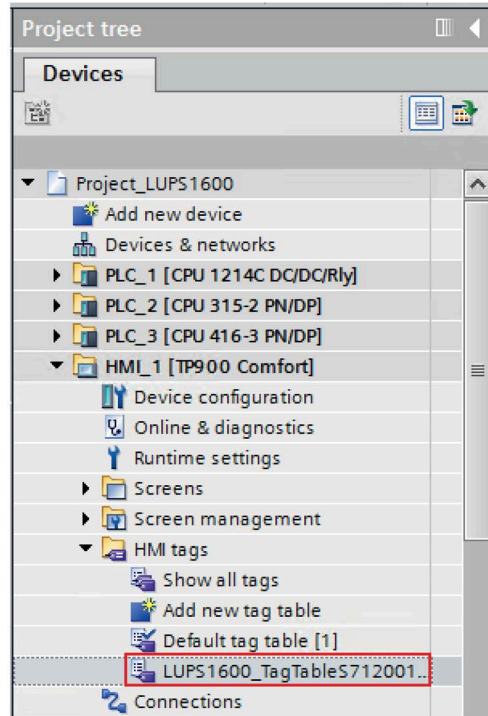

Figure 8-41



## Configuring the alarms display call

1. In the "Project tree", under the "HMI tags" folder open "LUPS1600\_TagTableS712001500RTAdv".



2. For the tags "alarmhistory" and "alarmpending", check if the assigned "Data type" is "Int" and the "Connection" is "Internal tag".

LUPS1600_TagTableS712001500RTAdv					
	Name ▲	Data type	Connection	PLC name	PLC tag
	alarmhistory	Int	<Internal tag>		<Undefined>
	alarmpending	Int	<Internal tag>		<Undefined>
	UPS_Data	LUPS1600_typeUPS1600...	HMI_Conne...	PLC_1	UPS_Global

Figure 8-42

3. Select the "alarmpending" tag and go to "Properties > Events > Value change". Check the properties of the tag where in the "ShowAlarmWindow" function is inserted and its variable "Object name" is assigned to the tag "Alarmview\_UPS\_Pending".

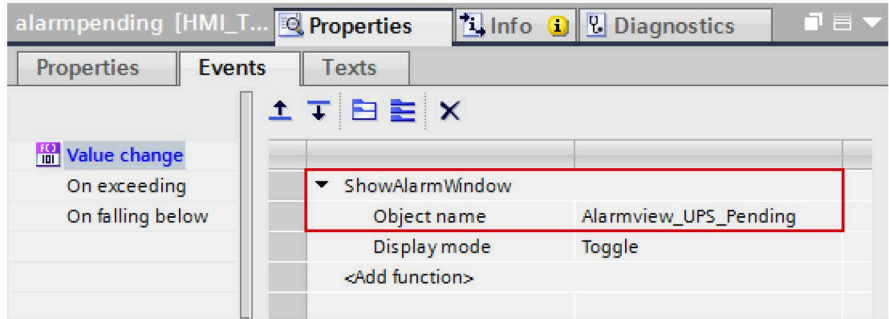

Figure 8-43

Similarly, check the properties of the tag "alarmhistory" where in the "ShowAlarmWindow" function is inserted and its variable "Object name" is assigned to the tag "Alarmview\_UPS\_History".

4. Open the screen (Screen\_1) and select the faceplate. Go to "Properties > Interface > Data".
5. Assign the "alarmhistory" tag to "AlarmviewBuffer" element.

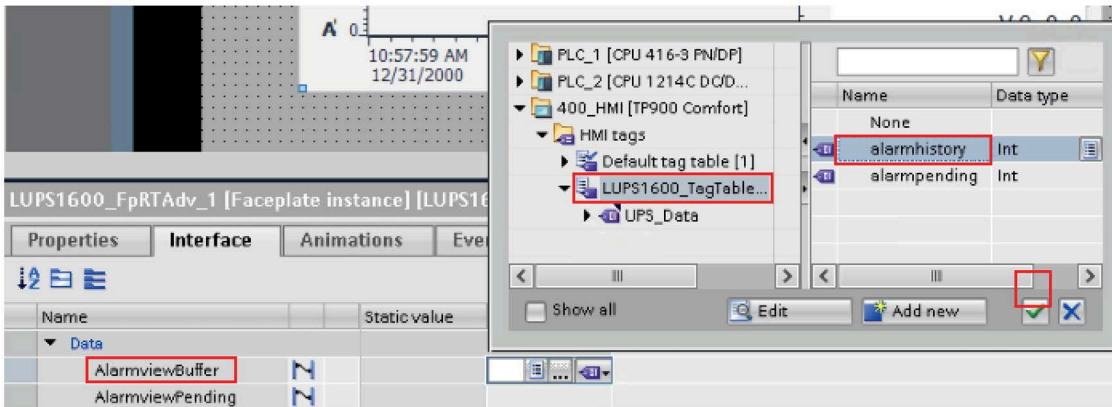

Figure 8-44

6. Assign the "alarmpending" tag to "AlarmviewPending" element.

## Displaying the PROFINET diagnostic messages

To display the PROFINET diagnostic messages of the SITOP UPS1600 within the faceplate, the respective WinCC TIA Portal project must already be configured.

Information on the display and configuration of diagnostic messages in WinCC TIA Portal is available under the entry ID 62121503

(<https://support.industry.siemens.com/cs/ww/en/view/62121503>).

Activation of the PROFINET diagnostic messages of the UPS1600 is found in the "Device view" of the UPS1600.

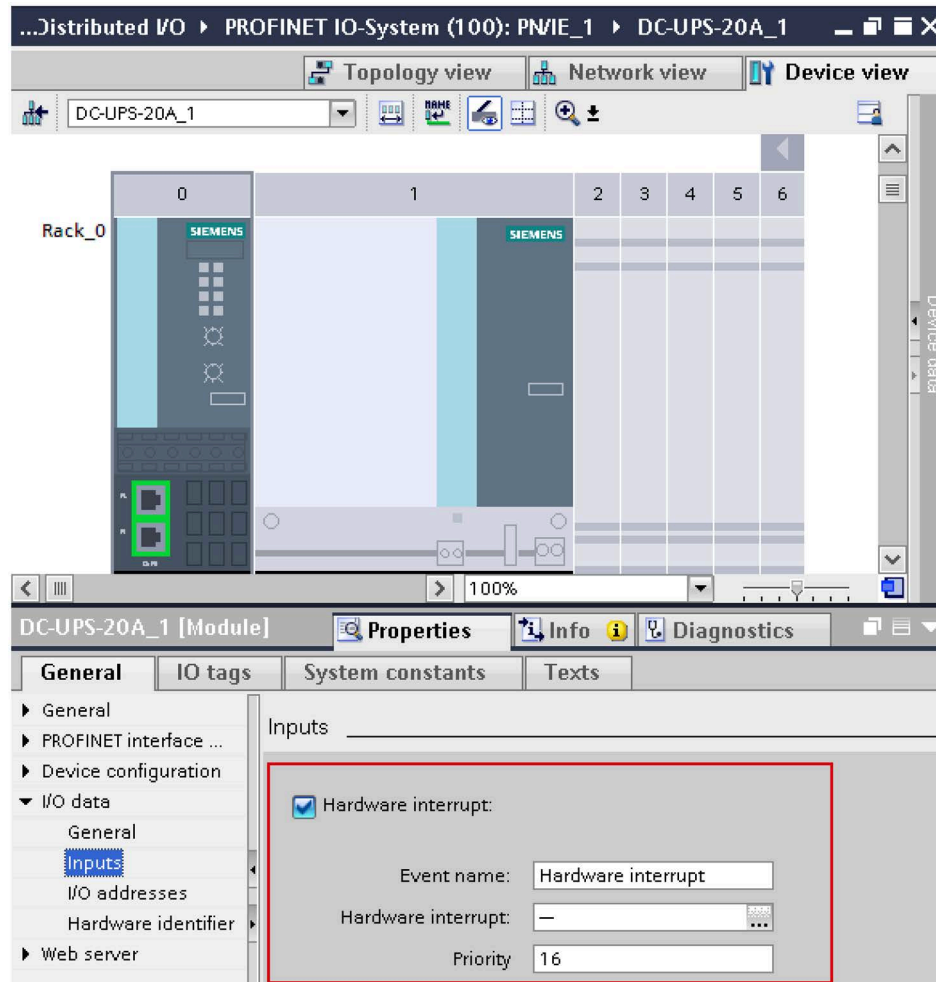

Figure 8-45

Further notes regarding the PROFINET diagnostic messages of the SITOP UPS1600 is available in the chapter 4 of the SITOP UPS1600 User Manual

(<https://support.industry.siemens.com/cs/ww/en/view/84977415>).

## 8.4 Application of screen windows in WinCC Professional V15.1

### 8.4.1 Prerequisites

#### Requirements

The following requirements must be met to use the screen windows in WinCC Professional V15.1:

- The HSP for the SITOP UPS1600 is installed in STEP 7 V15.1.
- S7 communication between the SITOP UPS1600 and SIMATIC S7 controller is already configured.
- All program blocks for STEP 7 V15.1 from LUPS1600 are integrated into the application program and executable.
- LUPS1600 is available on your computer.

#### Supported control panels

The screen windows are supported for the following control panels:

- WinCC RT Professional V15.1

#### Supported languages

The screen windows support the following languages:

- English (USA)
- German (Germany)
- Chinese (PR China)

## 8.4.2 Library for WinCC Professional

### Library for WinCC Professional

The following objects are part of the master copy "UPS1600 TIA Library > UPS1600 Wincc > Screens > Professional > ScreensRTProf" in LUPS1600:

Table 8- 3

Name	Type	Description
LUPS1600_ScrnWndwRTProf	Screen window	Comprises the screen window
LUPS1600_ScrnRTProf	Screen	Comprises the screen 'LUPS1600_ScrnRTProf'

## 8.4.3 Integrating the screen windows

### Overview

The following sections describe all the steps required to integrate the screen windows into a WinCC Professional V15.1 project.

Target system used:

- WinCC RT Professional V15.1

### Opening the library in WinCC V15.1

The procedure for opening the library in WinCC Professional V15.1 is explained in the Content of the library for STEP 7 V15.1 (Page 49).

## Inserting HMI tag table in WinCC

The following procedure describes how to insert HMI tag table into the WinCC project:

1. In the "Libraries" window, select "Global libraries > LUPS1600 > Master copies > LUPS1600 > WinCC > Professional > TagTablesRTProf > LUPS1600\_TagTableS712001500RTProf".

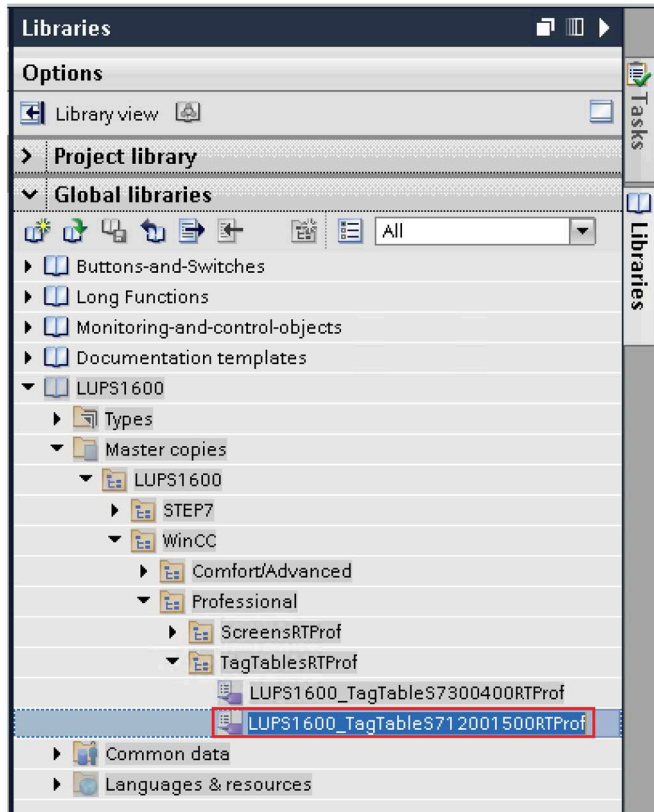

Figure 8-46

### Note

#### S7-300/400 PLCs

For S7-300/400 PLCs, select "LUPS1600\_TagTableS7300400RTProf".

2. Drag-and-drop "LUPS1600\_TagTableS712001500RTProf" into the "HMI tags" folder in the "Project tree".

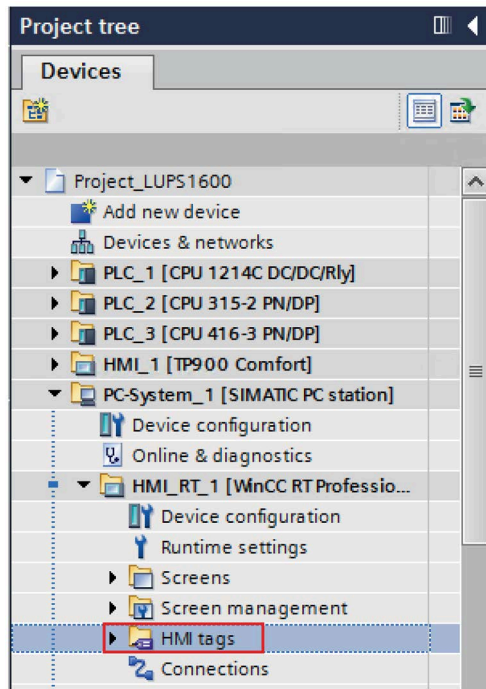

Figure 8-47

### Configuring connections of HMI tag table

The following procedure describes how to configure connections of HMI tag table:

1. In the "Project tree", select "HMI tags > LUPS1600\_TagTableS712001500RTProf" and open the tag table.

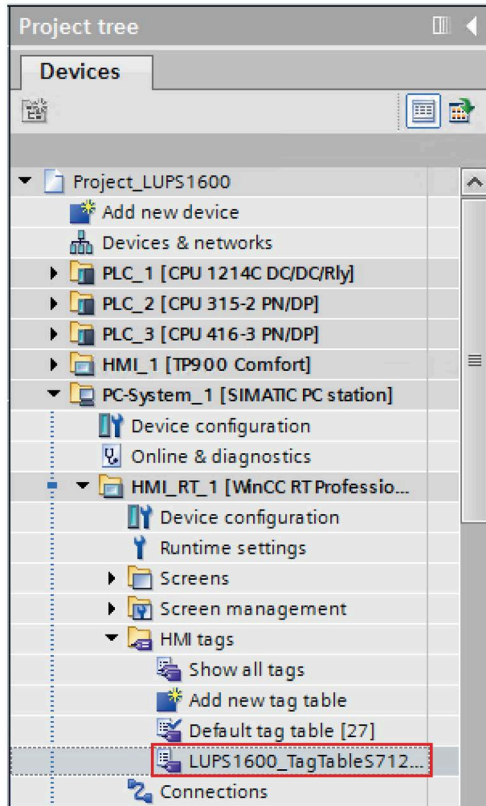

Figure 8-48

2. For the "UPS\_Data" tag, set the global DB (UPS\_Global) created in Procedure when using an S7-1200/1500 (Page 63) from the Program blocks.





**Note****For 300/400 PLCs,**

- For the "UPS\_Data" tag, make sure:
  - the "Connection" is set to "HMI\_Connection\_1".
  - the global DB number in the "Address" column is set to 2.

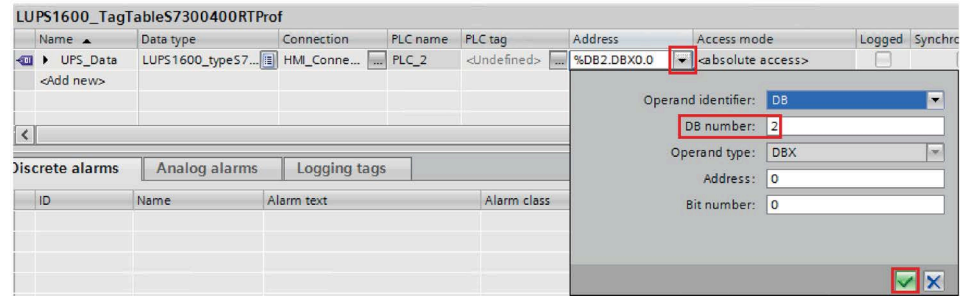
**Inserting screen windows into a project**

The following procedure describes how to integrate a screen from the library into an existing WinCC project:

1. Open the project in "Project view".
2. In the "Libraries" window, select "Global libraries > LUPS1600 > Master copies > LUPS1600 > WinCC > Professional > ScreensRTProf > LUPS1600\_ScrnRTProf".

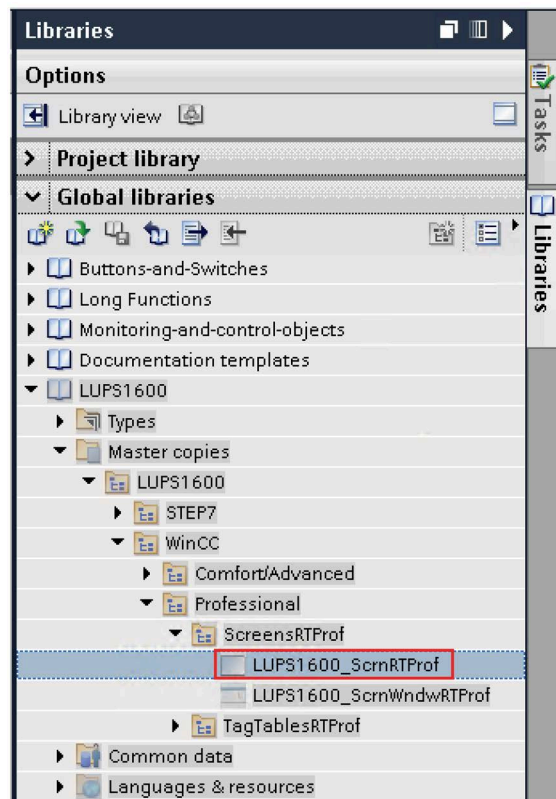
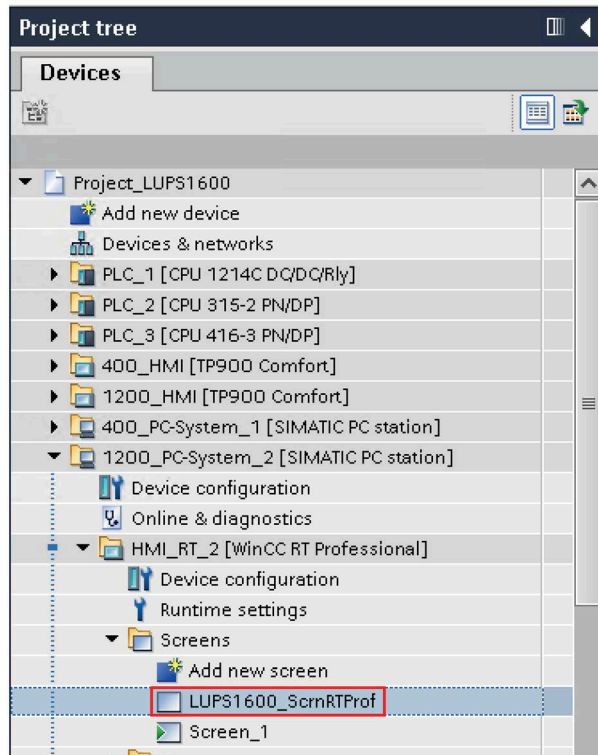

Figure 8-49

3. In the "Project tree", open the "Screens" folder of the HMI used in the project.
4. Drag-and-drop "LUPS1600\_ScrnRTProf" into the "Screens" folder.



## Integrating screen windows into a project

The following procedure describes how to integrate the screen window from the library into an existing WinCC project:

1. In the "Project tree", open the screen into which you want to insert the screen windows (Screen\_1).

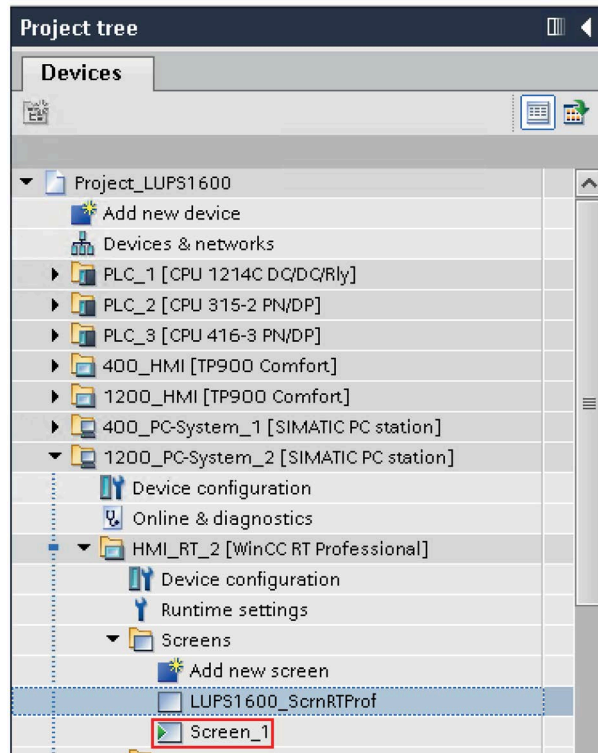

2. In the "Libraries" window, select "Global libraries > LUPS1600 > Master copies > LUPS1600 > WinCC > Professional > ScreensRTProf > LUPS1600\_ScrnWndwRTProf".

3. Drag-and-drop "LUPS1600\_ScrnWndwRTProf" to the screen.

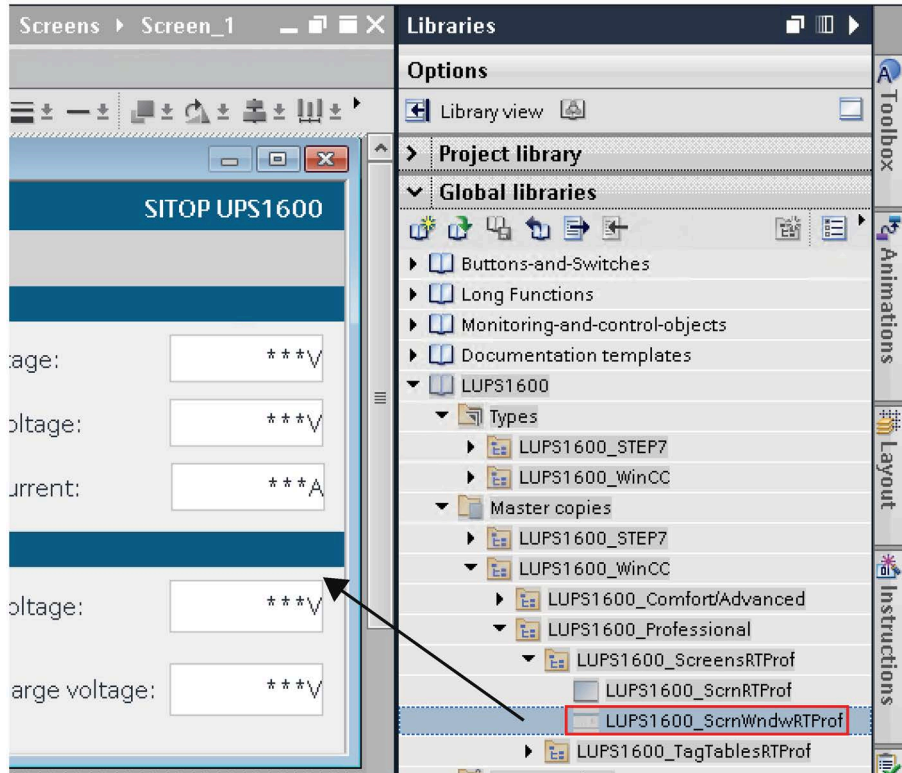

Figure 8-50

4. Select the screen window and go to "Properties > Properties > General".  
Assign "Tag prefix" variable with the "UPS\_Data" tag present in "LUPS1600\_TagTableS712001500RTProf" folder.

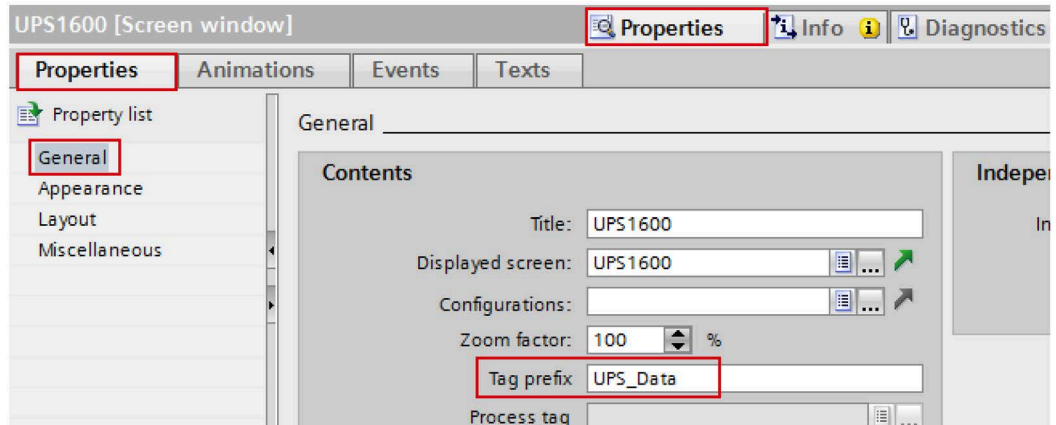

Figure 8-51

## Displaying the PROFINET diagnostic messages

To display the PROFINET diagnostic messages of the UPS1600 within the screen windows, the respective WinCC TIA Portal project must already be configured.

Information on the display and configuration of diagnostic messages in WinCC TIA Portal is available under the entry ID 62121503

(<https://support.industry.siemens.com/cs/ww/en/view/62121503>).

The activation of the PROFINET diagnostic messages of the UPS1600 is found in the "Device view" of the UPS1600.

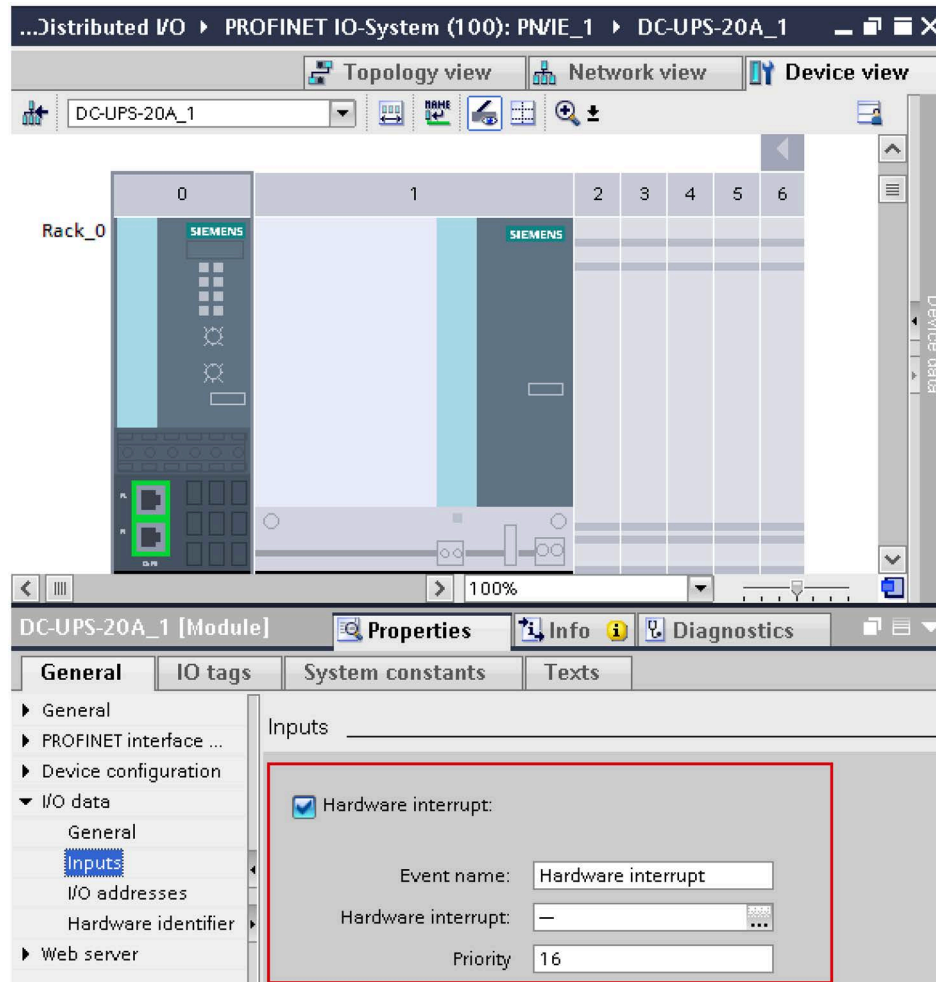

Figure 8-52

---

**Note**

- When configuring an S7-300/400 controller in TIA Portal, you also need to activate the S7 diagnostic alarm on the controller side.
  - The following entry describes how to proceed: 62121503 (<https://support.industry.siemens.com/cs/ww/en/view/62121503>), see Chapter 3.2.2 'Configuring CPU system diagnostic alarms', description 'Settings in STEP 7 Professional'.
  - There can be differences regarding the S7-1200 diagnosis with respect to the S7-1500.
- 

Further notes regarding the PROFINET diagnostic messages of the SITOP UPS1600 are available in the chapter 4 of the SITOP UPS1600 User Manual (<https://support.industry.siemens.com/cs/ww/en/view/84977415>).