

Indication and adjustment

RD150

4 ... 20 mA/HART

External display and adjustment unit

Operating Instructions • 07/2018



SITRANS

SIEMENS

Safety Guidelines: Warning notices must be observed to ensure personal safety as well as that of others, and to protect the product and the connected equipment. These warning notices are accompanied by a clarification of the level of caution to be observed.

Qualified Personnel: This device/system may only be set up and operated in conjunction with this manual. Qualified personnel are only authorized to install and operate this equipment in accordance with established safety practices and standards.

Unit Repair and Excluded Liability:

- The user is responsible for all changes and repairs made to the device by the user or the user's agent.
- All new components are to be provided by Siemens.
- Restrict repair to faulty components only.
- Do not reuse faulty components.

Warning: Cardboard shipping package provides limited humidity and moisture protection. This product can only function properly and safely if it is correctly transported, stored, installed, set up, operated, and maintained.

This product is intended for use in industrial areas. Operation of this equipment in a residential area may cause interference to several frequency based communications.

Note: Always use product in accordance with specifications.

Copyright Siemens AG 2015. All Rights Reserved	Disclaimer of Liability
This document is available in bound version and in electronic version. We encourage users to purchase authorized bound manuals, or to view electronic versions as designed and authored by Siemens. Siemens will not be responsible for the contents of partial or whole reproductions of either bound or electronic versions.	While we have verified the contents of this manual for agreement with the instrumentation described, variations remain possible. Thus we cannot guarantee full agreement. The contents of this manual are regularly reviewed and corrections are included in subsequent editions. We welcome all suggestions for improvement. Technical data subject to change.

Contact Siemens Technical Publications at the following address:

Technical Publications
Siemens Canada Limited
PD PA PI LW
1954 Technology Drive, P.O. Box 4225
Peterborough, Ontario, Canada, K9J 7B1
Email: techpubs.smpi@siemens.com

European Authorized Representative

Siemens AG
Industry Sector
76181 Karlsruhe
Deutschland

- For a selection of Siemens level measurement manuals, go to: **www.siemens.com/processautomation**. Under Process Instrumentation, select *Level Measurement* and then go to the manual archive listed under the product family.
- For a selection of Siemens weighing manuals, go to: **www.siemens.com/processautomation**. Under Weighing Technology, select *Continuous Weighing Systems* and then go to the manual archive listed under the product family.

Contents

1	About this document	5
1.1	Function	5
1.2	Target group	5
1.3	Symbols used.....	5
2	For your safety	6
2.1	Authorised personnel	6
2.2	Appropriate use.....	6
2.3	Warning about incorrect use.....	6
2.4	General safety instructions	6
2.5	EU conformity.....	7
2.6	NAMUR recommendations	7
2.7	Installation and operation in the USA and Canada	7
3	Product description	8
3.1	Configuration.....	8
3.2	Principle of operation.....	9
3.3	Packaging, transport and storage.....	10
3.4	Accessories and replacement parts	11
4	Mounting	12
4.1	General instructions	12
4.2	Mounting instructions	12
5	Connecting to power supply	15
5.1	Preparing the connection	15
5.2	Connection technology and steps	16
5.3	Wiring plan	18
5.4	Connection HART standard	18
5.5	Connection HART multidrop.....	19
5.6	Connection signal conditioning instrument/four-wire sensor	19
5.7	Connection example	20
5.8	Switch-on phase.....	20
6	Set up with the display and adjustment module	21
6.1	Short description	21
6.2	Insert display and adjustment module	21
6.3	Adjustment system	22
6.4	Measured value indication - Selection of national language	23
6.5	Start menu.....	24
6.6	Parameter adjustment - RD150.....	24
6.7	Parameter adjustment - Sensors via Generic HART.....	29
7	Setup via PACTware	31
7.1	Connect the PC	31
7.2	Parameter adjustment with PACTware	32
7.3	Saving the parameterisation data.....	33
8	Diagnostics and servicing	34
8.1	Maintenance	34
8.2	Asset Management function.....	34
8.3	Rectify faults.....	35

8.4	Software update	36
8.5	How to proceed if a repair is necessary.....	36
9	Dismount.....	37
9.1	Dismounting steps.....	37
9.2	Disposal	37
10	Supplement	38
10.1	Technical data	38
10.2	HART communication	41
10.3	Dimensions	42
10.4	Trademark	45

Safety instructions for Ex areas



Take note of the Ex specific safety instructions for Ex applications. These instructions are attached as documents to each instrument with Ex approval and are part of the operating instructions manual.

Editing status: 2018-07-12

1 About this document

1.1 Function

This operating instructions manual provides all the information you need for mounting, connection and setup as well as important instructions for maintenance, fault rectification, the exchange of parts and the safety of the user. Please read this information before putting the instrument into operation and keep this manual accessible in the immediate vicinity of the device.

1.2 Target group

This operating instructions manual is directed to trained personnel. The contents of this manual must be made available to the qualified personnel and implemented.

1.3 Symbols used



Information, tip, note

This symbol indicates helpful additional information.



Caution: If this warning is ignored, faults or malfunctions can result.



Warning: If this warning is ignored, injury to persons and/or serious damage to the instrument can result.



Danger: If this warning is ignored, serious injury to persons and/or destruction of the instrument can result.



Ex applications

This symbol indicates special instructions for Ex applications.



List

The dot set in front indicates a list with no implied sequence.



Action

This arrow indicates a single action.



Sequence of actions

Numbers set in front indicate successive steps in a procedure.



Battery disposal

This symbol indicates special information about the disposal of batteries and accumulators.

2 For your safety

2.1 Authorised personnel

All operations described in this documentation must be carried out only by trained specialist personnel authorised by the plant operator. During work on and with the device, the required personal protective equipment must always be worn.

2.2 Appropriate use

The RD150 is suitable for measured value indication and adjustment of 4 ... 20 mA/HART sensors.

You can find detailed information about the area of application in chapter "*Product description*".

Operational reliability is ensured only if the instrument is properly used according to the specifications in the operating instructions manual as well as possible supplementary instructions.

2.3 Warning about incorrect use

Inappropriate or incorrect use of this product can give rise to application-specific hazards, e.g. vessel overfill through incorrect mounting or adjustment. Damage to property and persons or environmental contamination can result. Also, the protective characteristics of the instrument can be impaired.

2.4 General safety instructions

This is a state-of-the-art instrument complying with all prevailing regulations and directives. The instrument must only be operated in a technically flawless and reliable condition. The operator is responsible for the trouble-free operation of the instrument. When measuring aggressive or corrosive media that can cause a dangerous situation if the instrument malfunctions, the operator has to implement suitable measures to make sure the instrument is functioning properly.

During the entire duration of use, the user is obliged to determine the compliance of the necessary occupational safety measures with the current valid rules and regulations and also take note of new regulations.

The safety instructions in this operating instructions manual, the national installation standards as well as the valid safety regulations and accident prevention rules must be observed by the user.

For safety and warranty reasons, any invasive work on the device beyond that described in the operating instructions manual may be carried out only by personnel authorised by the manufacturer. Arbitrary conversions or modifications are explicitly forbidden. For safety reasons, only the accessory specified by the manufacturer must be used.

To avoid any danger, the safety approval markings and safety tips on the device must also be observed and their meaning read in this operating instructions manual.

2.5 EU conformity

The device fulfils the legal requirements of the applicable EU directives. By affixing the CE marking, we confirm the conformity of the instrument with these directives.

2.6 NAMUR recommendations

NAMUR is the automation technology user association in the process industry in Germany. The published NAMUR recommendations are accepted as the standard in field instrumentation.

The device fulfils the requirements of the following NAMUR recommendations:

- NE 21 – Electromagnetic compatibility of equipment
- NE 53 – Compatibility of field devices and display/adjustment components

For further information see www.namur.de.

2.7 Installation and operation in the USA and Canada

This information is only valid for USA and Canada. Hence the following text is only available in the English language.

Installations in the US shall comply with the relevant requirements of the National Electrical Code (ANSI/NFPA 70).

Installations in Canada shall comply with the relevant requirements of the Canadian Electrical Code.

3 Product description

3.1 Configuration

Type label

The type label contains the most important data for identification and use of the instrument:

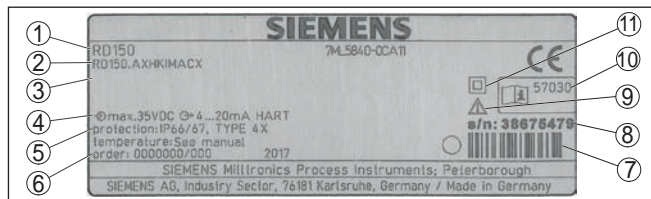

Fig. 1: Layout of the type label (example)

- 1 Instrument type
- 2 Product code
- 3 Field for approvals
- 4 Electronics/Voltage supply
- 5 Protection rating
- 6 Order number
- 7 Identification code
- 8 Serial number of the instrument
- 9 Reminder to observe the instrument documentation
- 10 ID number, instrument documentation
- 11 Device protection class

Instrument versions

The RD150 is available in different housing materials, see chapter "Technical data".

The instrument is optionally available with or without display and adjustment module.

Scope of this operating instructions manual

This operating instructions manual applies to the following instrument versions:

- Software from 1.10.00
- Hardware from 1.00.00

Scope of delivery

The scope of delivery encompasses:

- RD150
- Display and adjustment module (optional)
- Mounting accessories (optional)
- Documentation
 - This operating instructions manual
 - Ex-specific "Safety instructions" (with Ex versions)
 - If necessary, further certificates



Information:

In this operating instructions manual, the optional instrument features are also described. The actual range of functions is determined by the order specification.

3.2 Principle of operation

Application area

RD150 is suitable for measured value indication and adjustment of sensors with HART protocol. The instrument is looped directly into the 4 ... 20 mA HART signal line at any location. Separate external energy is not necessary. RD150 also operates exclusively as an indicating instrument in a 4 ... 20 mA current loop.

Sensor adjustment

The sensor adjustment is carried out in the RD150 integrated in the display and adjustment module.

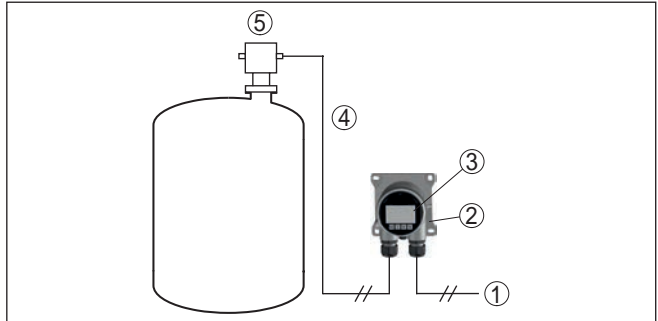

Fig. 2: Connection of the RD150 to the sensor, adjustment via the display and adjustment module

- 1 Voltage supply/Signal output sensor
- 2 RD150
- 3 Display and adjustment module
- 4 4 ... 20 mA/HART signal cable
- 5 Sensor

Sensor adjustment via PC with PACTware

The sensor adjustment is carried out via a PC with PACTware/DTM.

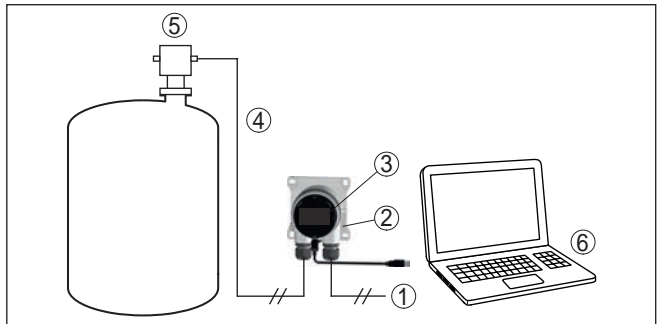

Fig. 3: Connection of the RD150 to the sensor and the PC, adjustment via PC with PACTware

- 1 Voltage supply/Signal output sensor
- 2 RD150
- 3 Interface adapter
- 4 4 ... 20 mA/HART signal cable
- 5 Sensor
- 6 PC with PACTware/DTM

Modes

4 ... 20 mA mode: when connected to a 4 ... 20 mA signal cable, RD150 operates exclusively as a display instrument.

Adjustment range: Indication scaling RD150

HART mode: when operated with a 4 ... 20 mA/HART sensor, the RD150 operates as display and HART adjustment instrument.

The parameter adjustment of the sensor is carried out via HART communication. During the parameter adjustment, the RD150 operates as a Primary or Secondary Master to the sensor.

Adjustment range: Sensor adjustment, indication scaling RD150

HART multidrop: the RD150 can be also used as an indicating device for a bus participant in a HART multidrop system.

Adjustment range: Sensor adjustment for a bus participant, indication scaling RD150

3.3 Packaging, transport and storage

Packaging

Your instrument was protected by packaging during transport. Its capacity to handle normal loads during transport is assured by a test based on ISO 4180.

The packaging of standard instruments consists of environment-friendly, recyclable cardboard. For special versions, PE foam or PE foil is also used. Dispose of the packaging material via specialised recycling companies.

Transport

Transport must be carried out in due consideration of the notes on the transport packaging. Nonobservance of these instructions can cause damage to the device.

Transport inspection

The delivery must be checked for completeness and possible transit damage immediately at receipt. Ascertained transit damage or concealed defects must be appropriately dealt with.

Storage

Up to the time of installation, the packages must be left closed and stored according to the orientation and storage markings on the outside.

Unless otherwise indicated, the packages must be stored only under the following conditions:

- Not in the open
- Dry and dust free
- Not exposed to corrosive media
- Protected against solar radiation
- Avoiding mechanical shock and vibration

Storage and transport temperature

- Storage and transport temperature see chapter "*Supplement - Technical data - Ambient conditions*"
- Relative humidity 20 ... 85 %

Lifting and carrying

With instrument weights of more than 18 kg (39.68 lbs) suitable and approved equipment must be used for lifting and carrying.

Display and adjustment module

3.4 Accessories and replacement parts

The display and adjustment module LG Local Display Interface is used for measured value indication, adjustment and diagnosis. It can be inserted into the sensor or the external display and adjustment unit and removed at any time.

You can find additional information in the operating instructions manual "*LG Local Display Interface*" (Document-ID 43838).

4 Mounting

4.1 General instructions

Installation position

RD150 functions in any installation position.

Protection against moisture

Protect your instrument against moisture ingress through the following measures:

- Use a suitable connection cable (see chapter "Connecting to power supply")
- Tighten the cable gland or plug connector
- When mounting horizontally, turn the housing so that the cable gland or plug connector point downward
- Lead the connection cable downward in front of the cable entry or plug connector.

This applies mainly to outdoor installations, in areas where high humidity is expected (e.g. through cleaning processes) and on cooled or heated vessels.

To maintain the housing protection, make sure that the housing lid is closed during operation and locked, if necessary.

Make sure that the degree of contamination specified in chapter "Technical data" meets the existing ambient conditions.

4.2 Mounting instructions

Wall mounting

The RD150 in all available housing materials is suitable for wall mounting.

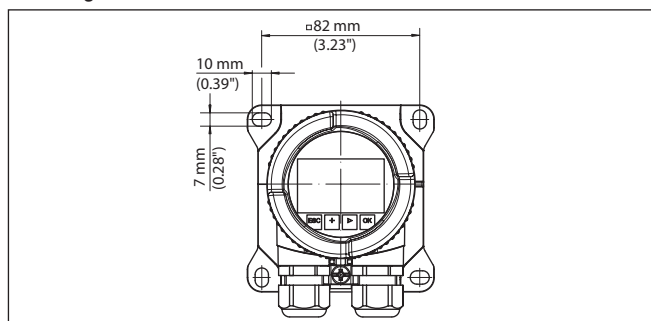

Fig. 4: Drilling dimensions for RD150 for wall mounting

Carrier rail mounting

The RD150 with plastic housing is suitable for direct carrier rail mounting according to EN 50022.

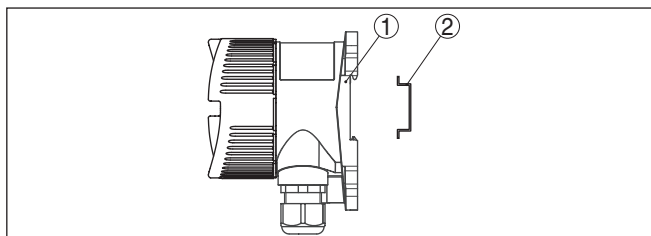

Fig. 5: RD150 with plastic housing for carrier rail mounting

- 1 Base
- 2 Carrier rail

The versions with aluminium or stainless steel housing for carrier rail mounting according to EN 50022 are supplied with unassembled mounting accessories. The kit consists of an adapter plate and four mounting screws M6 x 12.

The adapter plate is screwed to the base of RD150 by the user.

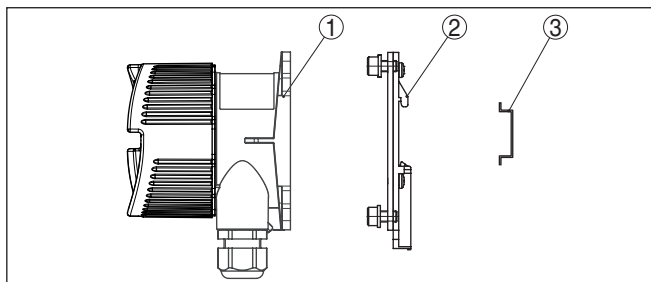

Fig. 6: RD150 with aluminium and stainless steel housing for carrier rail mounting

- 1 Base
- 2 Adapter plate with screws M6 x 12
- 3 Carrier rail

Tube mounting

The RD150 for tube mounting is supplied with unassembled mounting accessories. The kit consists of two pairs of mounting brackets and four mounting screws M6 x 100.

The mounting brackets are screwed to the base of RD150 by the user.

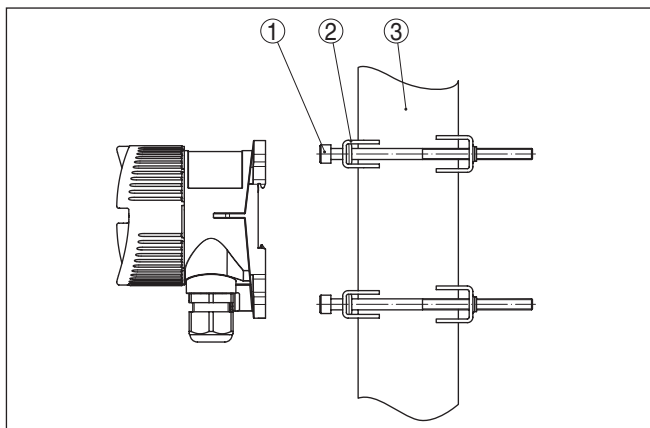

Fig. 7: RD150 for tube mounting

- 1 4 screws M6 x 100
- 2 Mounting brackets
- 3 Tube (diameter 1" to 2")

Front panel mounting

The RD150 is also available with a plastic housing for panel mounting. The housing is fastened to the rear of the panel by means of the supplied screw clamps.

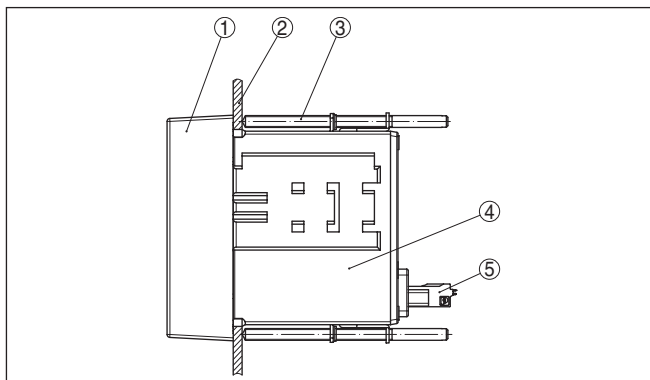

Fig. 8: RD150 for panel mounting

- 1 Inspection window
- 2 Front panel
- 3 Screw clamp
- 4 Housing
- 5 Plug connector

5 Connecting to power supply

5.1 Preparing the connection

Safety instructions

Always keep in mind the following safety instructions:

- Carry out electrical connection by trained personnel authorised by the plant operator
- If overvoltage surges are expected, overvoltage arresters should be installed



Warning:

Connect only in the complete absence of line voltage.

Voltage supply

Power supply and current signal are carried on the same two-wire cable. The voltage supply range can differ depending on the sensor.

The data for power supply are specified in chapter "*Technical data*".

Make sure that the supply circuits are separated from the mains circuits and of an energy-limited voltage supply, e.g. of "*Class 2*" (acc. to UL 1310, NEC 725 or CAN/CSA C22.2 No. 223), according to internationally harmonized standard IEC 61010-1.

Keep in mind the following additional factors that influence the operating voltage:

- Output voltage of the power supply unit can be lower under nominal load (with a sensor current of 20.5 mA resp. 22 mA in case of fault message)
- Voltage loss on the RD150 (see supply circuit in chapter "*Technical data*")

You can find information on the load resistance in chapter "*Technical data*", (voltage supply of the respective sensor)

Connection cable

The instrument is connected with standard two-wire cable without screen. If electromagnetic interference is expected which is above the test values of EN 61326-1 for industrial areas, screened cable should be used.

We generally recommend the use of screened cable for HART mode.

Use cable with round cross-section. To ensure the seal effect of the cable gland (IP protection rating), find out which cable outer diameter the cable gland is suitable for. Use a cable gland fitting the cable diameter.

You can find an overview of the cable glands in chapter "*Technical data*".

Cable glands

Metric threads

In the case of instrument housings with metric thread, the cable glands are screwed in at the factory. They are sealed with plastic plugs as transport protection.

You have to remove these plugs before electrical connection.

NPT thread

In the case of instrument housings with self-sealing NPT threads, it is not possible to have the cable entries screwed in at the factory. The free openings for the cable glands are therefore covered with red dust protection caps as transport protection.

Prior to setup you have to replace these protective caps with approved cable glands or close the openings with suitable blind plugs.

On plastic housings, the NPT cable gland or the Conduit steel tube must be screwed into the threaded insert without grease.

Max. torque for all housings, see chapter "*Technical data*".

Cable screening and grounding

If screened cable is necessary, we recommend connecting the cable screen on both ends to ground potential. In the RD150, the screen should be connected directly to the internal ground terminal.



In Ex systems it must be ensured that the grounding complies with the installation regulations.

In electroplating plants as well as plants for cathodic corrosion protection it must be taken into account that significant potential differences exist. This can lead to unacceptably high currents in the cable screen if it is grounded at both ends.

5.2 Connection technology and steps

Connection technology

The voltage supply and signal output are connected via the spring-loaded terminals in the housing.

Connection to the display and adjustment module or to the interface adapter is carried out via contact pins in the housing.



Information:

The terminal block is pluggable and can be removed from the electronics. To do this, lift the terminal block with a small screwdriver and pull it out. When reinserting the terminal block, you should hear it snap in.

Connection procedure

Proceed as follows:

1. Unscrew the housing lid
2. If a display and adjustment module is installed, remove it by turning it slightly to the left
3. Loosen compression nut of the cable gland and remove blind plug
4. Remove approx. 10 cm (4 in) of the cable mantle, strip approx. 1 cm (0.4 in) of insulation from the ends of the individual wires
5. Insert the cable into the sensor through the cable entry

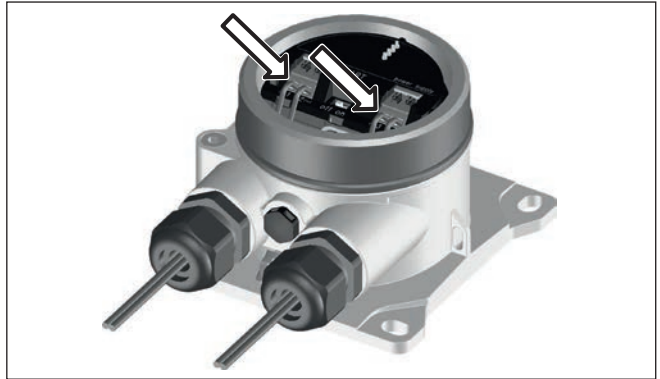

Fig. 9: Connection steps 5 and 6

6. Insert the wire ends into the terminals according to the wiring plan



Information:

Solid cores as well as flexible cores with wire end sleeves are inserted directly into the terminal openings. In case of flexible cores without end sleeves, press the terminal from above with a small screwdriver, the terminal opening is then free. When the screwdriver is released, the terminal closes again.

You can find further information on the max. wire cross-section under "*Technical data - Electromechanical data*".

7. Check the hold of the wires in the terminals by lightly pulling on them
8. Connect the screen to the internal ground terminal, connect the external ground terminal to potential equalisation
9. Tighten the compression nut of the cable entry gland. The seal ring must completely encircle the cable
10. Reinsert the display and adjustment module, if one was installed
11. Screw the housing lid back on

Wiring plan

5.3 Wiring plan

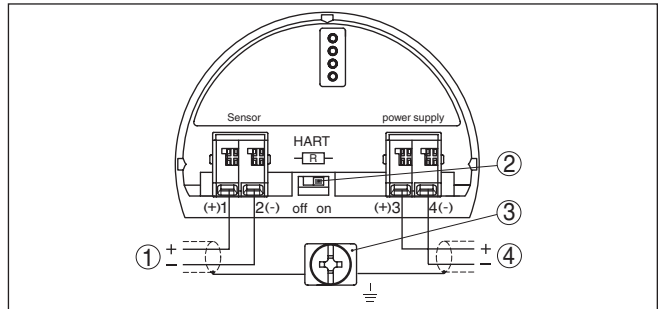

Fig. 10: Wiring plan RD150 4 ... 20 mA/HART

- 1 To the sensor
- 2 Switch for communication resistor (on = activated, off = deactivated)
- 3 Terminal for connection of the cable screen
- 4 For power supply

Wiring plan - Panel mounting

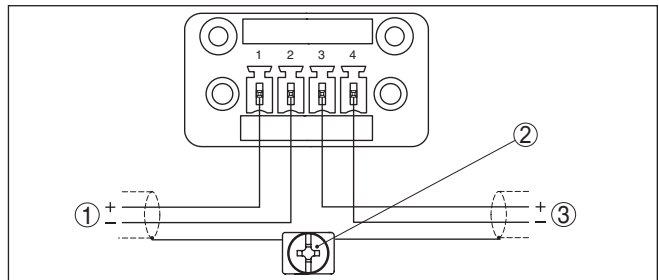

Fig. 11: Wiring plan RD150 for 4 ... 20 mA sensors - panel mounting

- 1 To the sensor
- 2 Ground terminal in the switching cabinet for connection of the cable screen
- 3 For power supply

5.4 Connection HART standard

The following illustration shows in a simplified way the use of RD150 in conjunction with a HART sensor.

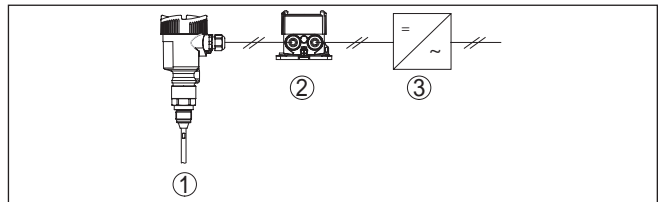

Fig. 12: Installation example RD150 in conjunction with an individual sensor

- 1 Sensor
- 2 RD150
- 3 Voltage supply/Processing

5.5 Connection HART multidrop

The following illustrations show in a simplified way the use of RD150 in conjunction with several HART sensors.

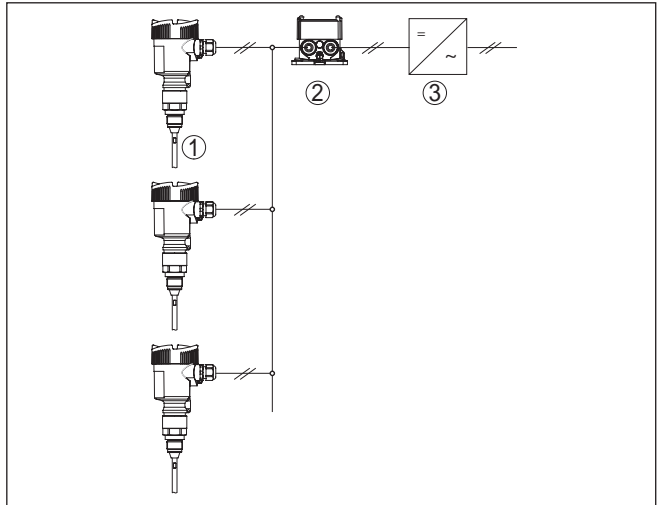

Fig. 13: Installation example with one RD150 for several sensors in a Multidrop system

- 1 Sensor
- 2 RD150
- 3 Voltage supply/Processing

5.6 Connection signal conditioning instrument/ four-wire sensor

Four-wire sensor with active 4 ... 20 mA output

The following illustration shows the simplified the connection of RD150 to a four-wire sensor with active 4 ... 20 mA output.

For this, terminals 1 and 4 on RD150 must be bridged.

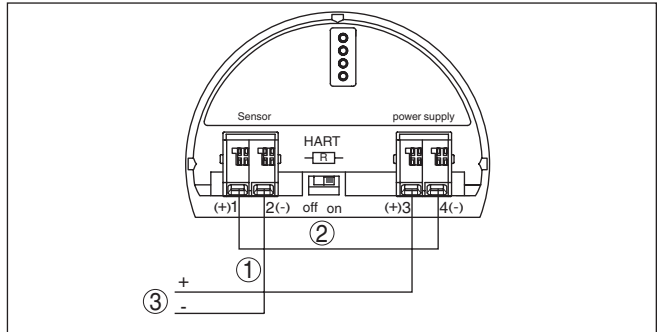

Fig. 14: Bridge between terminals 1 and 4 on the RD150

- 1 Bridge
- 2 RD150
- 3 Active sensor

5.7 Connection example

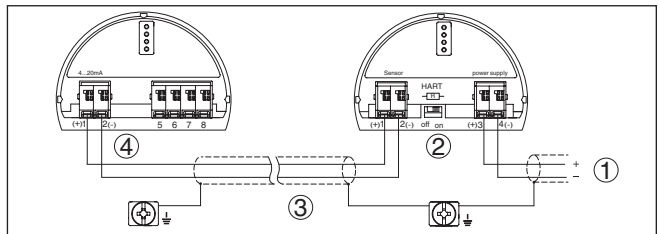

Fig. 15: Connection example 4 ... 20 mA/HART

- 1 Voltage supply
- 2 RD150
- 3 Connection cable
- 4 Sensor

5.8 Switch-on phase

After connecting the instrument to power supply or after a voltage recurrence, the instrument carries out a self-check for approx. 10 s:

- Internal check of the electronics
- Indication of the instrument type, hardware and software version, measurement loop name on the display or PC
- Indication of a status message on the display or PC

The duration of the warm-up phase depends on the connected sensor.

Then the actual measured value is displayed. You can find further information on the display in chapter "*Measured value indication - Selection national language*".

6 Set up with the display and adjustment module

Function/Configuration

6.1 Short description

The display and adjustment module is used for measured value display, adjustment and diagnosis. It can be mounted in the following housing versions and instruments:

- All continuously measuring sensors in single as well as double chamber housing version (optionally in the electronics or connection compartment)
- External display and adjustment unit



Note:

You can find detailed information on adjustment in the operating instructions manual "*Display and adjustment module*".

Mount/dismount display and adjustment module

6.2 Insert display and adjustment module

The display and adjustment module can be inserted into the RD150 and removed again at any time. It is not necessary to interrupt the power supply.



Note:

The operation of a display and adjustment module with integrated Bluetooth function is not supported by RD150.

Proceed as follows for mounting the display and adjustment module:

1. Unscrew the housing lid
2. Place the display and adjustment module in the desired position on the electronics (you can choose any one of four different positions - each displaced by 90°)
3. Press the display and adjustment module onto the electronics and turn it to the right until it snaps in
4. Screw housing lid with inspection window tightly back on

Disassembly is carried out in reverse order.

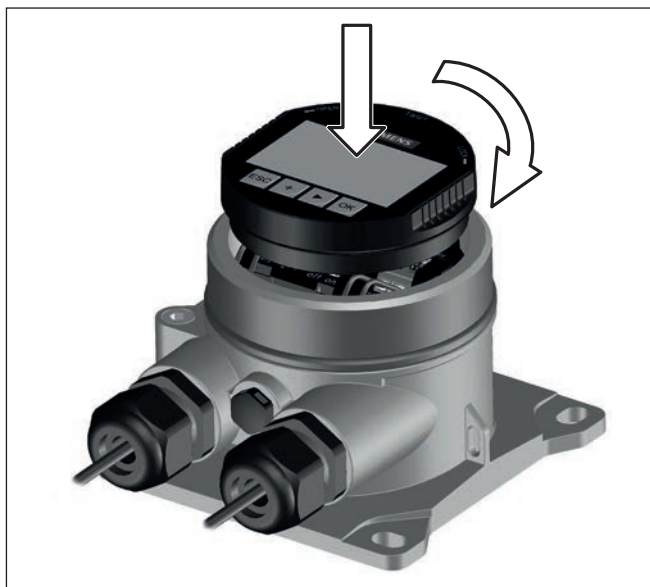

Fig. 16: Mounting of the display and adjustment module

6.3 Adjustment system

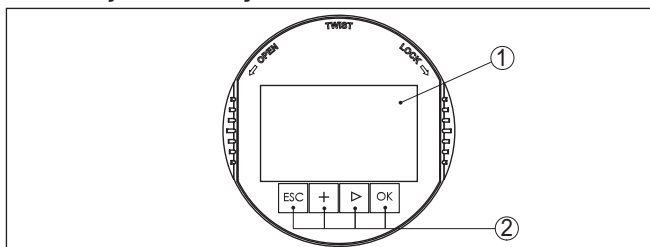

Fig. 17: Display and adjustment elements

- 1 LC display
- 2 Adjustment keys

Key functions

- **[OK]** key:
 - Move to the menu overview
 - Confirm selected menu
 - Edit parameter
 - Save value
- **[>]** key:
 - Change measured value presentation
 - Select list entry
 - Select menu items in the quick setup menu
 - Select editing position
- **[+]** key:

- Change value of the parameter

- **[ESC]** key:
 - Interrupt input
 - Jump to next higher menu

Adjustment system

The instrument is operated via the four keys of the display and adjustment module. The individual menu items are shown on the LC display. You can find the function of the individual keys in the previous illustration.

Time functions

When the **[+]** and **[->]** keys are pressed quickly, the edited value, or the cursor, changes one value or position at a time. If the key is pressed longer than 1 s, the value or position changes continuously.

When the **[OK]** and **[ESC]** keys are pressed simultaneously for more than 5 s, the display returns to the main menu. The menu language is then switched over to "English".

Approx. 60 minutes after the last pressing of a key, an automatic reset to measured value indication is triggered. Any values not confirmed with **[OK]** will not be saved.

6.4 Measured value indication - Selection of national language

Measured value indication

With the **[->]** key you can move between five different views:

First view: Display value 1 in big lettering, TAG number

Second view: Display value 1, a bargraph corresponding to the 4 ... 20 mA value, TAG number

Third view: Display values 1 and 2, TAG number

Fourth view: Display values 1, 2 and 3, TAG number

Fifth view: Display values 1, 2, 3 and 4, TAG number

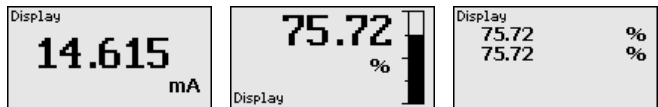

With the "OK" key you move (during the initial setup of the instrument) to the selection menu "Language".

Selection of national language

This menu item is used to select the national language for further parameter adjustment. A later change of the selection is possible via menu item "Setup - Display, Menu language".

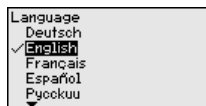

With the "OK" key you move to the start menu.

6.5 Start menu

Start menu

The start menu is divided into two sections with the following functions:

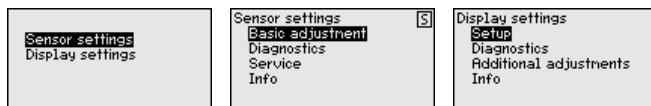

The selection branches into the following menus for parameter adjustment of the RD150 or the connected sensor.



Note:

The symbol "S" is displayed in the upper right corner of the display if there is a HART connection to the sensor.

6.6 Parameter adjustment - RD150

Main menu

The main menu is divided into four areas with the following functions:

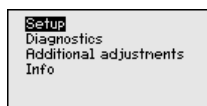

Setup: Settings, e.g. to measurement loop name, damping, scaling

Diagnosis: Information on the device status

Additional adjustments: Reset, copy display settings

Info: Instrument name, instrument version, date of manufacture, instrument features

For optimum adjustment of the instrument, the individual submenu items should be selected one after the other in the main menu item "Setup" and provided with the correct parameter values.

Setup - Measurement loop name

In the menu item "*Measurement loop name*" you edit a twelve digit measurement loop designation label.

You can enter an unambiguous designation for the measured value, e.g. the measurement loop name or the tank or product designation. In digital systems and in the documentation of larger plants, a singular designation must be entered for exact identification of individual measuring points.

The character set comprises the following ASCII signs with extension according to ISO 8859-1:

- Letters from A ... Z
- Numbers from 0 ... 9
- Special characters such as +, -, /, - etc.

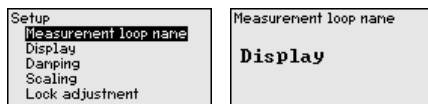

Setup - Display, menu language

This menu item allows a change of the national language.

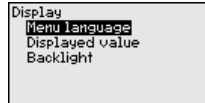
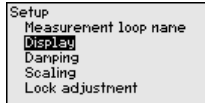

The following languages are available:

- German
- English
- French
- Spanish
- Russian
- Italian
- Dutch
- Portuguese
- Turkish
- Polish
- Czech

Setup - Display, indication value 1 to 4

In this menu item you define the indication of the measured values on the display. The selection comprises the current value in mA or scaled value as well as the HART values PV, SV, TV, QV.

The display values can be adjusted separately.

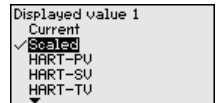
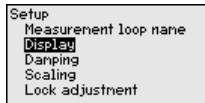

The default setting for the display value is "Current".

Setup - Display, lighting

The display and adjustment module has a backlight for the display. In this menu item you can switch on the lighting. You can find the required operating voltage in chapter "Technical data".

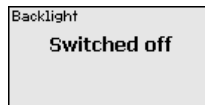
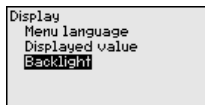

The lighting is switched off in delivery status.



Note:

The lighting switches off automatically when the current in the signal circuit is lower than 4 mA.

It switches on automatically when the current in the signal circuit is 4 mA or higher.

Setup - Damping

To damp process-dependent measured value fluctuations, set an integration time of 0 ... 999 s in this menu item. The increment is 0.1 s.

The entered integration time influences the current value and the display. The HART value remains unaffected.

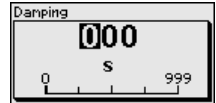
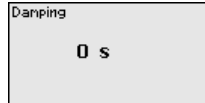
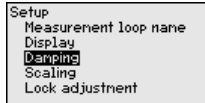

Factory setting is 0 s.

Setup - Scaling

In the menu item "*Scaling variable*" you define the scaling variable and unit of the measured value on the display, e.g. volume in l.

In addition to the offered standard units, there is the possibility, to create a user-defined unit.

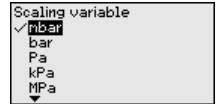
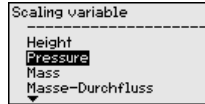
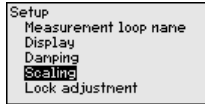

Furthermore, via menu item "*Scaling format*" you define the position of the comma and the assignment of the measured value for 0 % and 100 %.

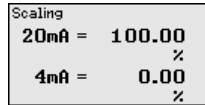
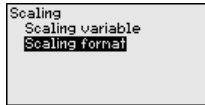

Lock/unlock setup - Adjustment

In the menu item "*Lock/unlock adjustment*", you can protect the instrument parameters against unauthorized modification. The PIN is activated/deactivated permanently.

With active PIN, only the following adjustment functions are possible without entering a PIN:

- Select menu items and show data
- Read data from the sensor into the display and adjustment module

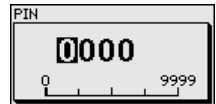
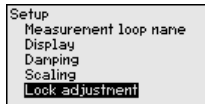

Caution:

When the PIN is active, adjustment via PACTware/DTM as well as other systems is also blocked.

The PIN number is entered while locking.

Diagnostics - Device status

In this menu item, the device status is displayed.

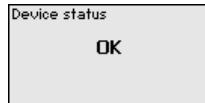
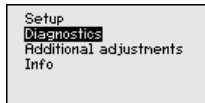

In case of instrument failure, an error code with text message is displayed. You can find information on cause and rectification in chapter "*Diagnosis and service*".

Additional settings - Reset

After a reset, certain parameter adjustments made by the user are reset.



The following reset functions are available:

Delivery status: Restores the parameter settings at the time of shipment Ex factory including the order-specific settings.

Basic settings: Resetting the parameter settings to the default values of the respective instrument.

The following table shows the default values of the instrument. Depending on the instrument version or application, all menu items may not be available or some may be differently assigned:

Reset - Setup

Menu item	Parameter	Default value
Measurement loop name		Display
Display	Language	English Order-specific
	Displayed value	Signal current
	Backlight	Switched off
Damping	Integration time	0 s
Scaling	Scaling size	%
	Scaling format	20 mA correspond to 100.00 % 4 mA correspond to 0.00 %
Lock adjustment		Released

Reset - Additional settings

Menu item	Parameter	Default value
HART	HART mode	Primary Master
	HART address	Address 0

Additional adjustments - Copy display settings

With this function, the display settings are copied.

The following parameters or settings are saved:

- All parameters of the menu "Setup" as well as the menu item "Additional adjustments - HART mode"



The copied data are permanently saved in the display and adjustment module. They remain even in case of voltage loss.



Note:

Before the data are stored in the instrument, they are checked to make sure they match the instrument. For this purpose, the instrument type of the source data as well as the target instrument are displayed. Storage takes place only after approval.

Additional adjustments - HART mode

With the parameter "HART Master mode" you define the instrument function as either Primary or Secondary Master.

The parameter "HART address", defines the address of the sensor RD150 communicates with via HART.

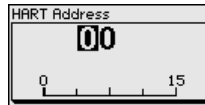
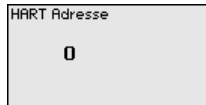
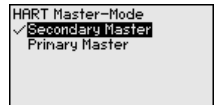
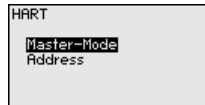
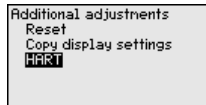

The factory setting is "Secondary Master" and the address 00.

Info - Instrument name

In this menu item, you can read out the instrument name and the instrument serial number:

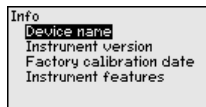

Info - Instrument version

In this menu item, the hardware and software version of the sensor is displayed.

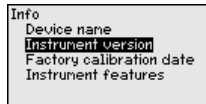

Info - Factory calibration date

In this menu item, the date of the factory calibration of the instrument as well as the date of the last change of sensor parameters is displayed via the PC.

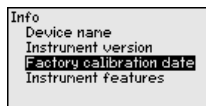

Info - Instrument features

In this menu item, instrument features such as approvals, electronics, housing as well as others are displayed.

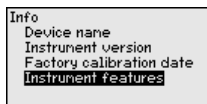

6.7 Parameter adjustment - Sensors via Generic HART

Main menu

The main menu is divided into three areas with the following functions:

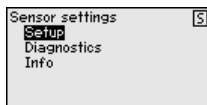

Setup: Settings, for example measurement loop name, PV unit, Upper and Lower Range, damping

Diagnosis: Information, for example on the device status

Info: Instrument name

The submenu points are described below.

Setup - Sensor TAG

In the menu item "Sensor TAG" you edit a twelve-digit measurement loop designation.

You can enter an unambiguous designation for the sensor, e.g. the measurement loop name or the tank or product designation. In digital systems and in the documentation of larger plants, a singular designation must be entered for exact identification of individual measuring points.

The available digits include:

- Letters from A ... Z
- Numbers from 0 ... 9
- Special characters +, -, /, -

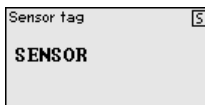
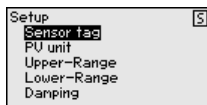

Setup - PV unit

In this menu item, the unit of the PV (Primary Value) adjusted on the sensor is displayed, e.g. bar. The selection determines the displayed unit in the menu items "Lower Range" and "Upper Range".

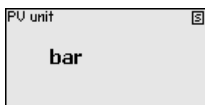
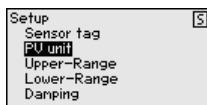

Enter the requested parameters via the appropriate keys, save your settings with **[OK]** and jump to the next menu item with the **[ESC]** and the **[->]** key.

Setup - Upper Range

In this menu item, the measuring range final value of the sensor is set. Proceed as follows:

1. Select with **[->]** the menu item "Upper Range" and confirm with **[OK]**.

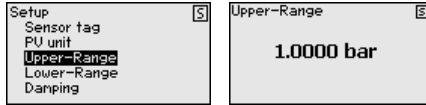

2. Edit the value with **[OK]** and set the cursor to the requested position with **[->]**.
3. Set the requested value with **[+]** and store with **[OK]**.
4. With "ESC" you can return to the menu overview "Setup".

The adjustment of the Upper Range is hence finished.

Setup - Lower Range

In this menu item, the measuring range beginning value of the sensor is set.

Proceed as follows:

1. Select with **[->]** the menu item "Lower Range" and confirm with **[OK]**.

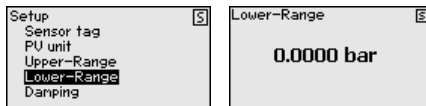

2. Edit the percentage value with **[OK]** and set the cursor to the requested position with **[->]**.
3. Edit the value with **[OK]** and set the cursor to the requested position with **[->]**.
4. Set the requested value with **[+]** and store with **[OK]**.
5. With "ESC" you can return to the menu overview "Setup".

The adjustment of the Lower Range is hence finished.

Setup - Damping

To damp process-dependent measured value fluctuations, set an integration time of 0 ... 999 s in this menu item. The increment is 1 s.



Diagnostics - Device status

In this menu item, the device status is displayed.



Info - Serial number

In this menu item, you read out the instrument serial number:

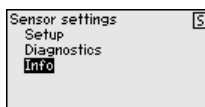

7 Setup via PACTware

7.1 Connect the PC

Via interface adapter

The PC is connected via the interface adapter to the device.

Parameter adjustment options:

- RD150
- Sensor

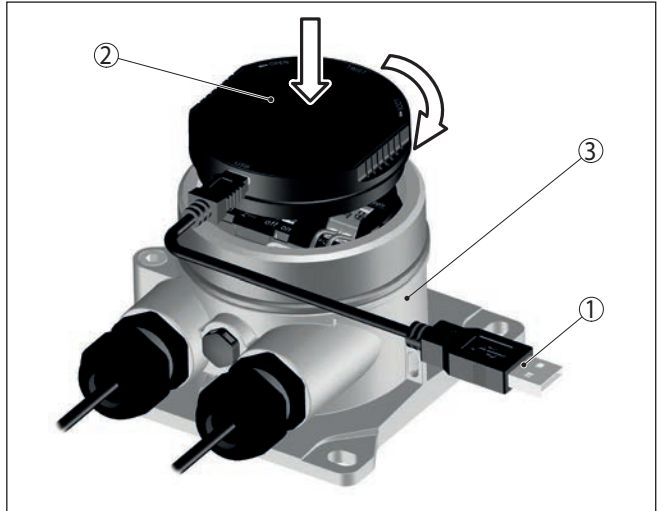

Fig. 18: Connection of the PC via interface adapter

- 1 USB cable to the PC
- 2 Interface adapter
- 3 RD150

Via HART modem

The PC is connected via a HART modem to the sensor side of the RD150.

Parameter adjustment options:

- Sensor

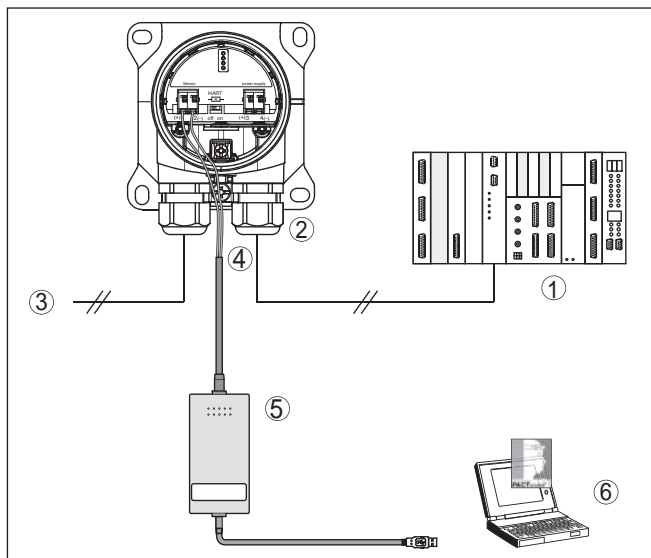

Fig. 19: Connecting the PC via HART to the signal cable

- 1 Processing system/PLC/Voltage supply
- 2 RD150
- 3 To the sensor
- 4 Connection cable with 2 mm pins and terminals
- 5 HART modem
- 6 PC

7.2 Parameter adjustment with PACTware

Prerequisites

For parameter adjustment of the sensor via a Windows PC, the configuration software PACTware and a suitable instrument driver (DTM) according to FDT standard are required. The available DTMs are compiled on a DVD. The DTMs can also be integrated into other frame applications according to FDT standard.



Note:

To ensure that all instrument functions are supported, you should always use the latest DTM. Furthermore, not all described functions are included in older firmware versions. You can download the latest instrument software from our homepage. A description of the update procedure is also available in the Internet.

The further setup steps are described in the online help of PACTware and the DTMs.

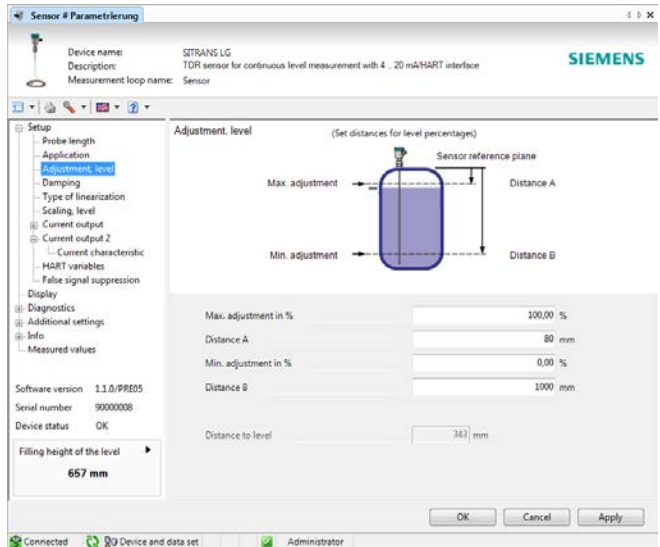

Fig. 20: Example of a DTM view

Device DTMs

The device DTM includes an assistant for simple project configuration simplifying also the adjustment considerably. You can save and print your project documentation as well as import and export projects.

You can also save measured value and echo curves in the DTM. Furthermore a tank calculation program as well as a multiviewer for indication and analysis of the saved measured value and echo curves are available.

The supplied DVD includes the respective device DTM. However, you can also download the DTM from our homepage www.siemens.com/sitranslg.

7.3 Saving the parameterisation data

We recommend documenting or saving the parameterisation data via PACTware. That way the data are available for multiple use or service purposes.

8 Diagnostics and servicing

8.1 Maintenance

Maintenance

If the device is used properly, no special maintenance is required in normal operation.

Cleaning

The cleaning helps that the type label and markings on the instrument are visible.

Take note of the following:

- Use only cleaning agents which do not corrode the housings, type label and seals
- Use only cleaning methods corresponding to the housing protection rating

8.2 Asset Management function

Sensors

The instrument supports the self-monitoring and diagnosis of the connected sensor. Status or failure messages are displayed according to the sensor via display and adjustment module, PACTware/DTM and EDD.

You can find a detailed overview of this function in the operating instructions of the respective sensor.

External display and adjustment unit

The following table shows the error codes and text messages of the RD150 and gives information on the cause and removal.

Code Text message	Cause	Rectification
S003 CRC-error	● CRC error during self-check	● Carry out a reset ● Send instrument for repair
F008 Sensor not found	● Sensor in boot phase ● HART communication malfunctioning	● Check sensor connection ● Check HART address sensor
F013 Sensor or measurement loop malfunctioning	● Sensor signals error, no valid measured value	● Check sensor parameter adjustment ● Send instrument for repair
F014 Sensor input: Short-circuit	● Short-circuit or sensor current > 21 mA	● Check cable ● Check sensor
F015 Sensor input: Line break	● Line break or sensor current < 3.6 mA	● Check cable ● Check sensor, probably already in the run-in period
S021 Scaling: Span too small	● Scaling span too small	● Carry out scaling again ● Increase the distance between min. and max. scaling

Code Text message	Cause	Rectification
S022 Scaling: Value too high	<ul style="list-style-type: none"> ● Scaling value too high 	<ul style="list-style-type: none"> ● Check scaling values, correct, if necessary
S030 Measured value: not valid	<ul style="list-style-type: none"> ● Sensor in boot phase ● Measured value not valid 	<ul style="list-style-type: none"> ● Check sensor parameter adjustment
F034 EEPROM: CRC error	<ul style="list-style-type: none"> ● EEPROM: CRC error 	<ul style="list-style-type: none"> ● Switch the instrument off and on ● Carry out reset to default setting ● Send instrument for repair
F035 ROM: CRC error	<ul style="list-style-type: none"> ● ROM: CRC error 	<ul style="list-style-type: none"> ● Switch the instrument off and on ● Carry out reset to default setting ● Send instrument for repair
F036 No executable software version	<ul style="list-style-type: none"> ● Instrument software not executable (during software update or after failed update) 	<ul style="list-style-type: none"> ● Wait until software update is finished ● Carry out another software update
F037 RAM defective	<ul style="list-style-type: none"> ● Error of the RAM in the internal data memory 	<ul style="list-style-type: none"> ● Switch the instrument off and on ● Carry out reset to default setting ● Send instrument for repair
F040 General hardware error	<ul style="list-style-type: none"> ● Hardware error 	<ul style="list-style-type: none"> ● Switch the instrument off and on ● Carry out reset to default setting ● Send instrument for repair
S053 Sensor measuring range too small	<ul style="list-style-type: none"> ● Sensor measuring range not read correctly 	<ul style="list-style-type: none"> ● HART communication error: Check sensor cable and screening ● Switch the instrument off and on

8.3 Rectify faults

Reaction when malfunction occurs

The operator of the system is responsible for taking suitable measures to rectify faults.

Check the 4 ... 20 mA signal

Connect a multimeter in the suitable measuring range according to the wiring plan. The following table describes possible errors in the current signal and helps to eliminate them:

Error	Cause	Rectification
4 ... 20 mA signal not stable	<ul style="list-style-type: none"> ● Fluctuating measured value 	<ul style="list-style-type: none"> ● Set damping

Error	Cause	Rectification
4 ... 20 mA signal missing	● Electrical connection faulty	● Check connection, correct, if necessary
	● Voltage supply missing	● Check cables for breaks; repair if necessary
	● Operating voltage too low, load resistance too high	● Check, adapt if necessary
Current signal greater than 22 mA, less than 3.6 mA	● Sensor electronics defective	● Exchange the instrument or send it in for repair

Reaction after fault rectification

Depending on the reason for the fault and the measures taken, the steps described in chapter "Setup" must be carried out again or must be checked for plausibility and completeness.

8.4 Software update

The following components are required to update the sensor software:

- Sensor
- Voltage supply
- PC with PACTware
- Current sensor software as file

You can find the actual sensor software as well as detailed information of the procedure in the download area on our homepage: www.siemens.com/sitranslg.

You can find information about the installation in the download file.



Caution:

Instruments with approvals can be bound to certain software versions. Therefore make sure that the approval is still effective after a software update is carried out.

You can find detailed information in the download area on our homepage: www.siemens.com/sitranslg.

8.5 How to proceed if a repair is necessary

If it is necessary to repair the instrument, please contact the agency serving you.

9 Dismount

9.1 Dismounting steps



Warning:

Before dismounting, be aware of dangerous process conditions such as e.g. pressure in the vessel or pipeline, high temperatures, corrosive or toxic products etc.

Take note of chapters "*Mounting*" and "*Connecting to power supply*" and carry out the listed steps in reverse order.

9.2 Disposal

The instrument consists of materials which can be recycled by specialised recycling companies. We use recyclable materials and have designed the electronics to be easily separated.

WEEE directive 2002/96/EG

This instrument is not subject to the WEEE directive 2002/96/EG and the respective national laws. Pass the instrument directly on to a specialised recycling company and do not use the municipal collecting points. These may be used only for privately used products according to the WEEE directive.

Correct disposal avoids negative effects on humans and the environment and ensures recycling of useful raw materials.

Materials: see chapter "*Technical data*"

If you have no way to dispose of the old instrument properly, please contact us concerning return and disposal.

10 Supplement

10.1 Technical data

Materials and weights

Materials

- | | |
|--|---|
| - Plastic housing | Plastic PBT (Polyester) |
| - Aluminium housing | Aluminium die-casting AlSi10Mg, powder-coated (Basis: Polyester) |
| - Stainless steel housing | 316L precision casting, blasted |
| - Seal between housing and housing lid | NBR (stainless steel housing), silicone (Aluminium/plastic housing) |
| - Inspection window in housing cover (in version with display and adjustment module) | Polycarbonate, coated |
| - Cable gland/Seal insert | PA/NBR |
| - Ground terminal | 316L |

Deviating materials - Ex-d version

- | | |
|--|--------------------------|
| - Inspection window in housing cover (in version with display and adjustment module) | Single-pane safety glass |
| - Cable gland/Seal insert | Brass nickel-plated/NBR |

Materials for carrier rail mounting

- | | |
|------------------------------------|------------------|
| - Adapter plate, housing side | 316 |
| - Adapter plate, carrier rail side | Zinc die casting |
| - Mounting screws | 316 |

Materials for tube mounting

- | | |
|-------------------|------|
| - Brackets | StSt |
| - Mounting screws | StSt |

Materials for panel mounting

- | | |
|---------------------|-------------------|
| - Housing | PPE |
| - Transparent cover | PS |
| - Screw clamps | St, nickel plated |

Weights without mounting elements approx.

- | | |
|---------------------------|---------------------|
| - Plastic housing | 0.35 kg (0.772 lbs) |
| - Aluminium housing | 0.7 kg (1.543 lbs) |
| - Stainless steel housing | 2.0 kg (4.409 lbs) |

Mounting elements approx.

- | | |
|---|--------------------|
| - Brackets for tube mounting | 0.4 kg (0.882 lbs) |
| - Adapter plate for carrier rail mounting | 0.5 kg (1.102 lbs) |

Torques

Max. torque for NPT cable glands and Conduit tubes

- Plastic housing 10 Nm (7.376 lbf ft)
 - Aluminium/Stainless steel housing 50 Nm (36.88 lbf ft)
-

Signal and supply circuit

Operating voltage max. 35 V DC

Voltage drop with current value 4 ... 20 mA

- Without lighting max. 1.7 V
- With lighting max. 3.2 V
- With activated HART resistance additionally max. 4.5 V

HART resistance 200 Ω

Current range 3.5 ... 22.5 mA¹⁾

Overcurrent resistance 100 mA

Reverse voltage protection Available

Functional safety SIL non-reactive

Current measurement (reference temperature 20 °C)

Measuring range loop current 3.5 ... 22.5 mA

Deviation ± 0.1 % of 20 mA

Temperature coefficient ± 0.1 % of the span/10 K

Interval 250 ms

Display and adjustment module

Display element Display with backlight

Measured value indication

- Number of digits 5

Adjustment elements

- 4 keys *[OK], [->], [+], [ESC]*

Protection rating

- unassembled IP 20
- mounted in the housing without lid IP 40

Materials

- Housing ABS
- Inspection window Polyester foil

Functional safety SIL non-reactive

Adjustment elements

Slide switch in the connection compartment Activate/deactivate the integrated communication resistance for HART

¹⁾ If the loop current is not sufficient for operation, the display does not work. When the measured values are outside the measuring range, a message is displayed instead of the measured value.

Ambient conditions

Storage and transport temperature -40 ... +80 °C (-40 ... +176 °F)

Ambient temperature

– without display and adjustment module -40 ... +80 °C (-40 ... +176 °F)

– With display and adjustment module -20 ... +70 °C (-4 ... +158 °F)

Process conditions

Vibration resistance 4 g at 5 ... 200 Hz according to EN 60068-2-6 (vibration with resonance)

Vibration resistance with carrier rail mounting 1 g at 5 ... 200 Hz according to EN 60068-2-6 (vibration with resonance)

Shock resistance 100 g, 6 ms according to EN 60068-2-27 (mechanical shock)

Electromechanical data

Options of the cable entry

– Cable entry M20 x 1.5, ½ NPT

– Cable gland M20 x 1.5, ½ NPT

– Blind plug M20 x 1.5; ½ NPT

– Closing cap ½ NPT

Connection terminals

– Type Spring-loaded terminal

– Stripping length 8 mm

Wire cross-section of the connection cable (according to IEC 60228)

– Massive wire, stranded wire 0.2 ... 2.5 mm² (AWG 24 ... 14)

– Stranded wire with end sleeve 0.2 ... 1.5 mm² (AWG 24 ... 16)

Electromechanical data - Panel mounting

Terminals, plug connector

– Type Spring-loaded terminal

– Stripping length 8 mm

Wire cross-section of the connection cable (according to IEC 60228)

– Massive wire, stranded wire 0.2 ... 1.5 mm² (AWG 24 ... 16)

– Stranded wire with end sleeve 0.25 ... 0.75 mm² (AWG 24 ... 18)

Electrical protective measures

Protection rating

– Plastic housing IEC 60529 IP 66/IP 67, NEMA Type 4X

– Housing for panel mounting (mounted) IEC 60529 IP 40, NEMA Type 1

– Aluminium/Stainless steel housing IEC 60529IP 66/IP 68 (0.2 bar), NEMA Type 6P

Connection of the feeding power supply unit Networks of overvoltage category III

Altitude above sea level

- by default up to 2000 m (6562 ft)
- with connected overvoltage protection up to 5000 m (16404 ft)

Pollution degree²⁾ 4

Protection class II

10.2 HART communication

The HART protocol operates with frequency shift keying (FSK) based on the data communication standard Bell 202. The digital signal is generated from the frequencies 1200 and 2200 Hz, which represent the bit information 1 and 0. Sine curves with these frequencies are superimposed on the direct current in the wire pair of the field instrument. The average value of the superimposed signal is zero. For that reason, the 4 ... 20 mA signal is not influenced by the simultaneous digital data transmission.

Supported HART commands

Command no.	Command name	Description
0	Read Unique Identifier	Sensor identification
1	Read primary variable	Primary Value with unit
3	Read current 4 Variables	PV, SV, QV, TV with unit
13	Read Tag, descriptor, date	Sensor TAG, ...
15	Read output information	Scaling values
18	Write Damping value	Damping
34	Write Tag, descriptor, date	Sensor TAG, ...
35	Write range values	Write scaling values
36	Set upper range value	Max. adjustment/SPAN
37	Set lower range value	Min. adjustment/ZERO
44	Write PV units	PV unit

²⁾ When used with fulfilled housing protection

10.3 Dimensions

RD150, plastic housing

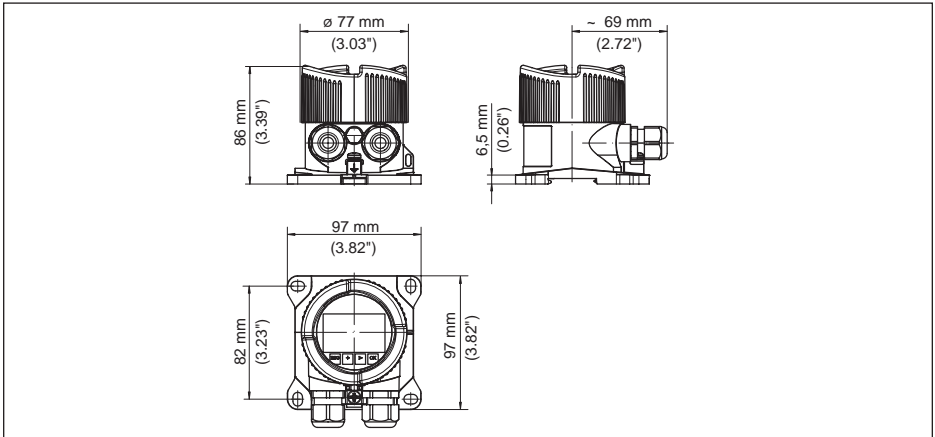

Fig. 21: RD150 with plastic housing

RD150, plastic housing (panel mounting)

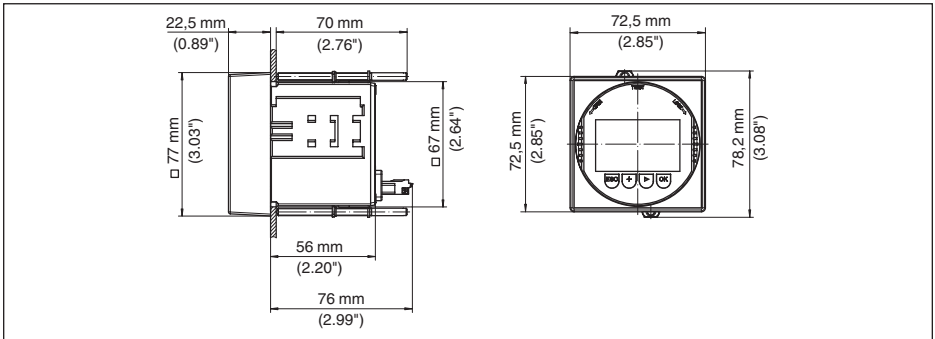

Fig. 22: RD150 with plastic housing for panel mounting

RD150, aluminium housing

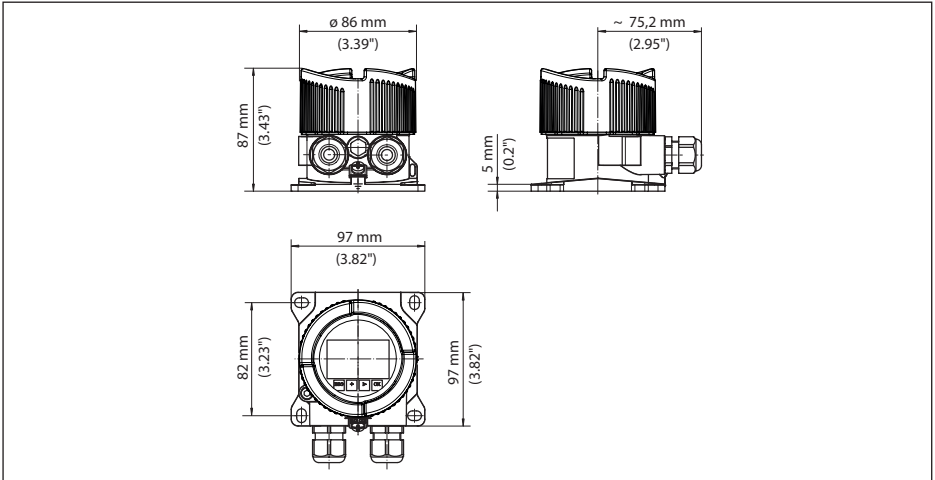

Fig. 23: RD150 with Aluminium housing

RD150, stainless steel housing (precision casting)

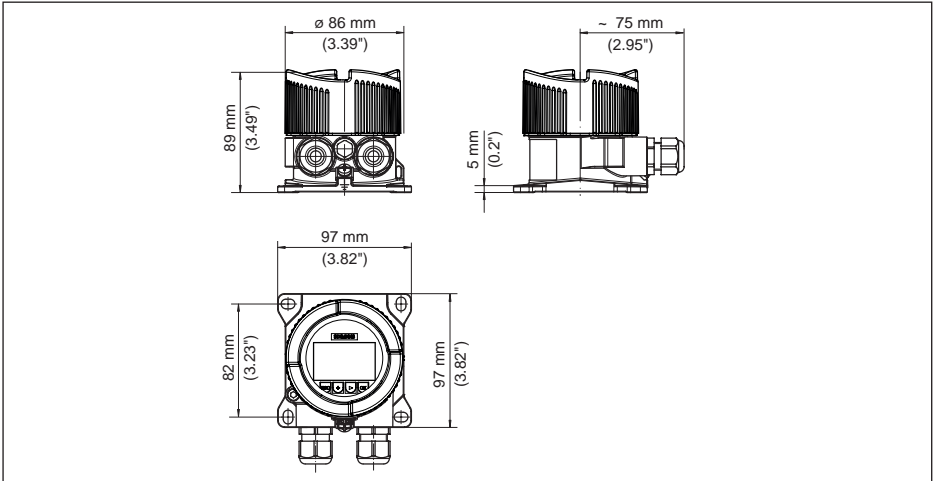

Fig. 24: RD150, with stainless steel housing (precision casting)

Mounting elements

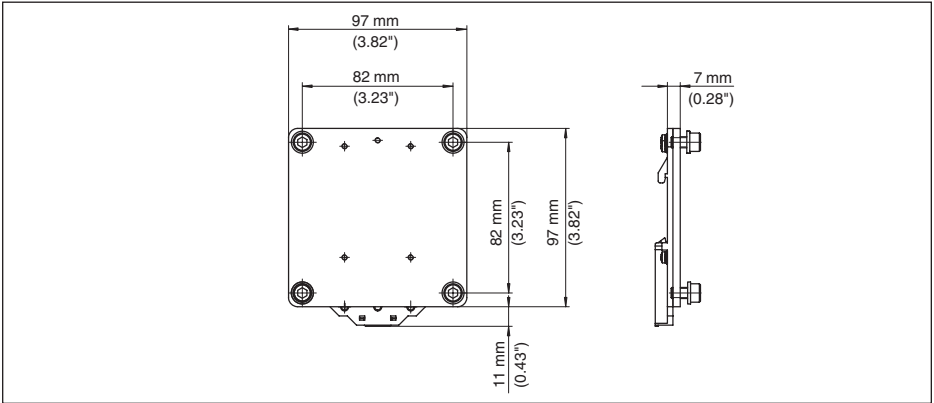

Fig. 25: Adapter plate for carrier rail mounting of RD150

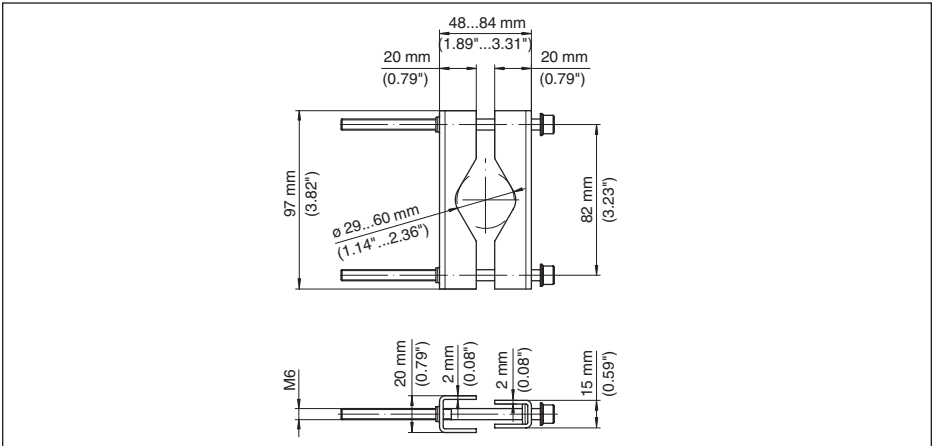

Fig. 26: Brackets for tube mounting of RD150

10.4 Trademark

All the brands as well as trade and company names used are property of their lawful proprietor/originator.

INDEX

A

Adjustment

- Lower Range 30
- System 23
- Unit 29
- Upper Range 29

Adjustment menu 24

Application area 9

C

Change the language 24

Check output signal 35

Connection

- Cable 15
- Steps 16
- Technology 16

Copy sensor settings 27

D

Damping 25, 30

Default values 27

Display lighting 25

E

Error codes 34

G

Grounding 16

H

HART mode 28

I

Instrument versions 8

L

Lock adjustment 26

M

Modes 10

Mounting

- Carrier rail 12
- Front panel 14
- Position 12
- Tube 13

R

Recycling 37

Repair 36

Reset 27

S

Scaling 26

Set display parameters 25

T

Type label 8

V

Voltage supply 15

W

WEEE directive 37

Notes

For more information

www.siemens.com/level

www.siemens.com/weighing



Siemens Canada Limited
PD PA PI LW
1954 Technology Drive
P.O. Box 4225
Peterborough, ON
K9J 7B1, Canada

email: techpubs.smpi@siemens.com

www.siemens.com/processautomation

Subject to change without prior notice
MAN-100472 Rev. 1.0

© Siemens AG 2018



MAN-100472

Printed in Canada